



Specification for TFT

AFA544506A0R-3.6IWTH

Revision 1.0



A	Orient Display
FA	TFT Type
544506	Resolution 544 x 506
A0R	Serial A0, Round
3.6	3.6", Module Dimension 98.88 x 94.12 x 7.71 mm
I	IPS Display
W	Top: -30~+85°C; Tstr: -30~+85°C
T	Transmissive
H	Hight Brightness, 1000cd/m2
/	No Touch Panel
/	ST72566 OR COMPATIBLE
/	RGB 24bit interface(TFT)



Record of Revisions

Version	Revise Date	Description	Page
1.0	2023.7.13	First Release	-

Contents

1. General Specifications	4
2. Absolute Maximum Ratings	4
3. Electrical Characteristics	5
4. Interface Pin Assignment	6
5. Interface Characteristics	7
6. Optical Specifications	14
7. Reliability Test Items	17
8. Mechanical Drawing	18
9. Packing	19
10. Precautions for Use of LCD modules	20

1. General Specifications

1.1 LCM General Information

Item	Specification	Unit
LCD Size	3.6	inch
Number of Pixels	544 (H) RGB x 506 (V)	pixels
Display Mode	Normally Black	-
Viewing Direction	Free	o' clock
Interface	RGB	-
Display Colors	16.7M	colors
Outline Dimension	98.88 (H) x 94.12 (V) x 7.71 (D)	mm
Active Area	89.76 (H) x 83.49 (V)	mm
Pixel Pitch	0.1650 (H) x 0.1650 (V)	mm
Driver IC	ST72566	-
Operation Temperature	-30~85	°C
Storage Temperature	-30~85	°C

Note1:Requirements on environmental protection RoHS compliant.

2. Absolute Maximum Ratings

Item	Symbol	MIN.	MAX.	Unit	Note
Analog Supply voltage	VDD	-0.3	5.0	V	Note 1

Note 1:Permanent damage may occur to the LCD module if beyond this specification.

Functional operation should be restricted to the conditions described under normal operating conditions.

3. Electrical Characteristics

3.1 Recommended Operating Condition for TFT LCD

Item	Symbol	Min.	Typ.	Max.	Unit	Note
Analog Supply voltage	VDD	3.0	3.3	3.6	V	
Analog supply current	I _{VDD}	-	TBD	-	mA	VDD=3.3V
Logic input voltage	V _{IH}	0.7*VDD	-	VDD	V	
	V _{IL}	GND	-	0.3*VDD	V	

3.2 Recommended Driving Condition for Backlight

Item	Symbol	Min.	Typ.	Max.	Unit	Note
Driving Current	I _F	-	180	-	mA	
Driving Voltage	V _F	13.5	-	17.0	V	
Power consumption	W _{BL}	2.43	-	3.06	W	
LED Life-Time	N/A	-	50,000	-	Hours	Ta=25°C Note 1

Note 1: LED lifetime is defined as the module brightness decay 50% of original brightness at Ta=25 degree, typical current.

Note 2: LED circuit :

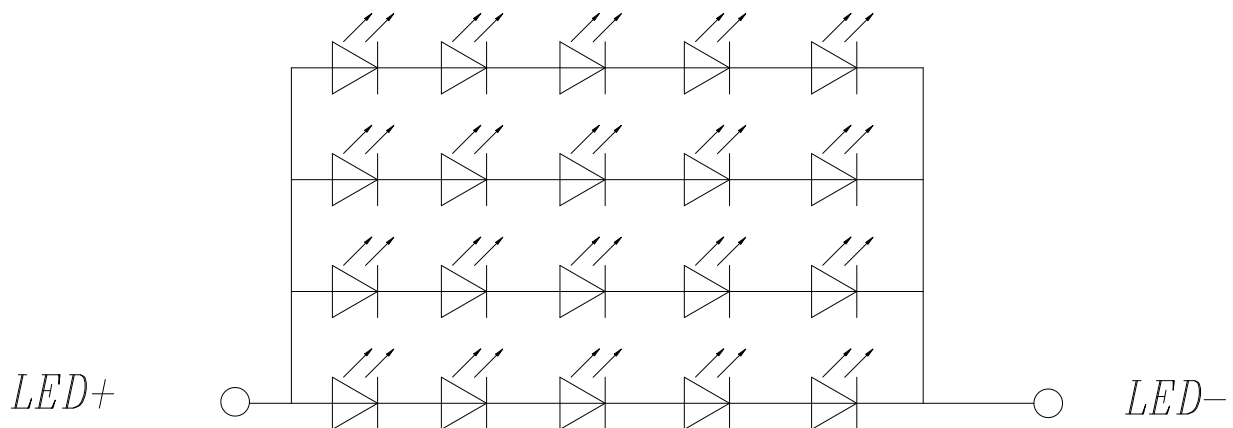

4. Interface Pin Assignment

4.1 LCM Pin Assignment

No.	Symbol	Description
1	LED-K	Power for LED backlight (Cathode)
2	LED+A	Power for LED backlight (Anode)
3	GND	Ground
4	VDD	Power supply
5-12	R0-R7	Data bus
13-20	G0-G7	Data bus
21-28	B0-B7	Data bus
29	GND	Ground
30	PCLK	Dot clock signal input. Latching input data at its rising edge
31	DISP	Standby mode. Normally pulled high DISP="1": Normally operation (Default) DISP="0": Timing controller, source driver will turn off ,all output are High
32	HSYNC	Horizontal sync input Negative polarity
33	VSYNC	Vertical sync input Negative polarity
34	DEN	Display enable pin for controller
35	NC	No connection
36	GND	Ground
37	NC	No connection
38	NC	No connection
39	NC	No connection
40	NC	No connection

5. Interface Characteristics

5.1 POWER ON/OFF SEQUENCE

5.1.1 Power On Sequence

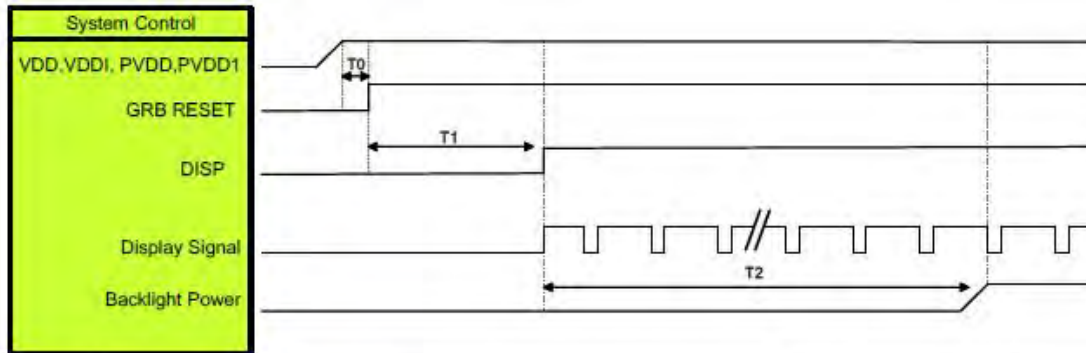

Symbol	Description	Min. Time	Unit
T0	System power stability to GRB RESET signal	0	ms
T1	GRB RESET="High" to DISP="High"	10	ms
T2	Display Signal output to Backlight Power on	250	ms

Note :

1. When DISP pull "H" or "L", IC will execute the internal power on or power off procedures .Please be careful about the timing of DISP and do not interrupt it during power on or power off procedure, otherwise unexpected errors will occur.
2. RGB interface Display signal: DCLK; VSYNC; HSYNC; DE; DR[7:0]; DG[7:0]; DB[7:0]
- 3: LVDS interface Display signal: DCLK P/N; RX[3:0] P/N

5.1.2 Power Off Sequence

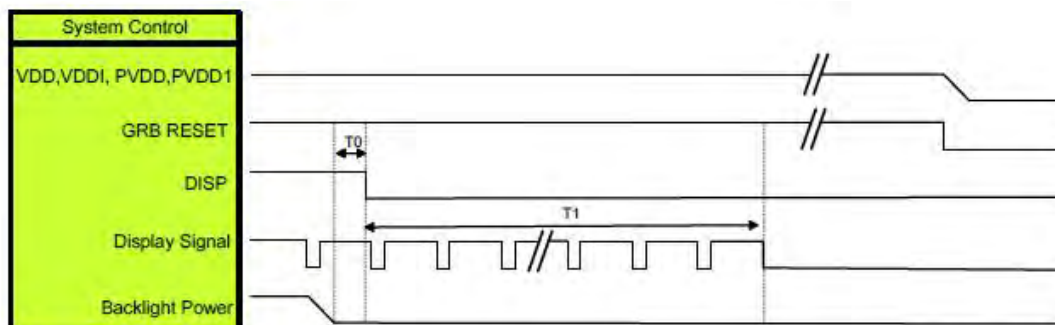

Symbol	Description	Min. Time	Unit
T0	Backlight Power off to DISP="Low"	5	ms
T1	DISP="Low" to IC internal voltage discharge complete	100	ms

Note :

1. When DISP pull "H" or "L", IC will execute the internal power on or power off procedures .Please be careful about the timing of DISP and do not interrupt it during power on or power off procedure, otherwise unexpected errors will occur.
2. RGB interface Display signal: DCLK; VSYNC; HSYNC; DE; DR[7:0]; DG[7:0]; DB[7:0]
- 3: LVDS interface Display signal: DCLK P/N; RX[3:0] P/N

5.2 RGB Interface

RGB Mode Selection Table	DCLK	HSYNC	VSYNC	DE
SYNC - DE Mode	Input	Input	Input	Input
SYNC Mode	Input	Input	Input	GND
DE Mode	Input	GND	GND	Input

Note: "Input" means these signals are driven by host side

5.2.1 SYNC Mode

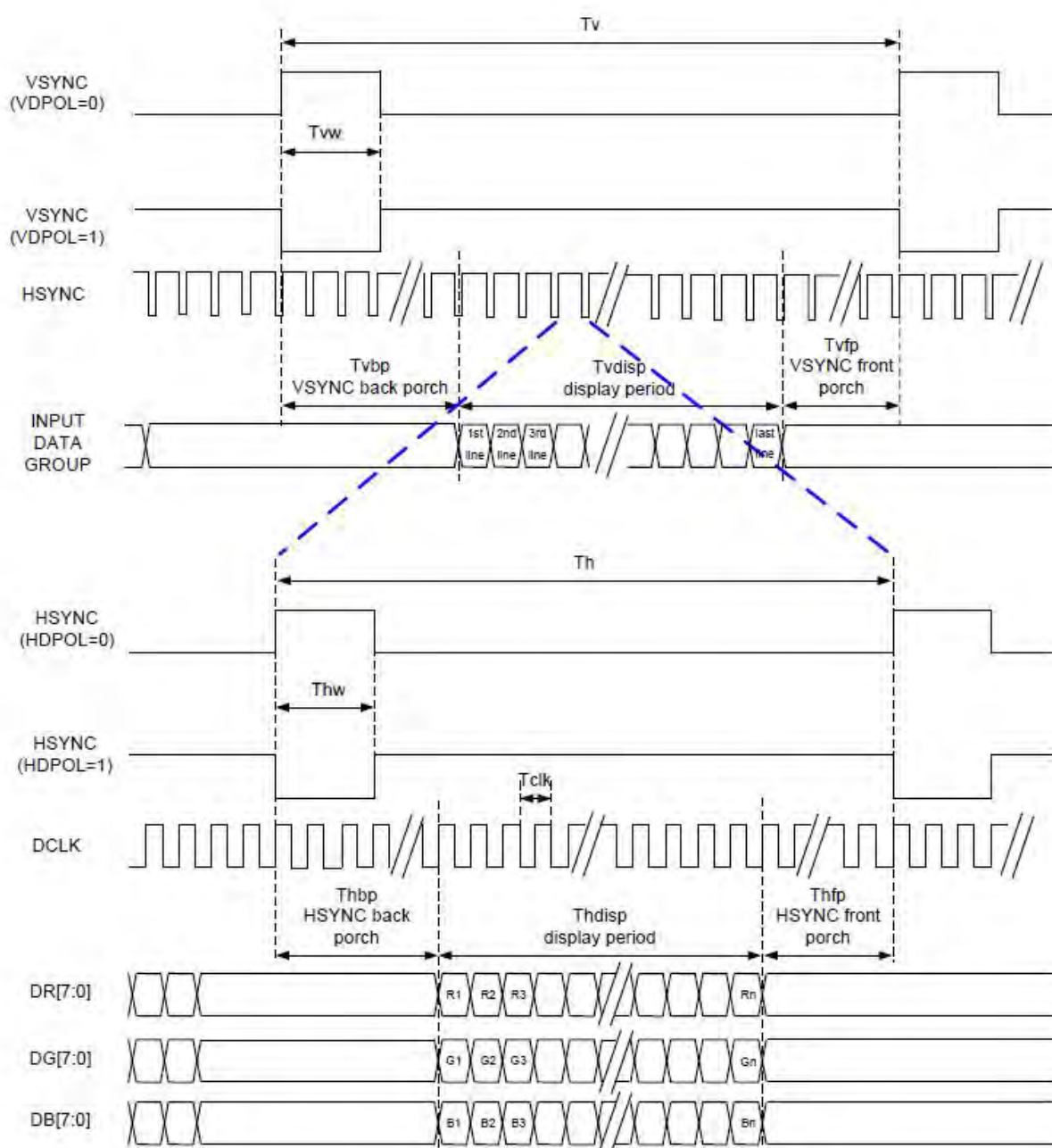

5.2.2 SYNC-DE Mode

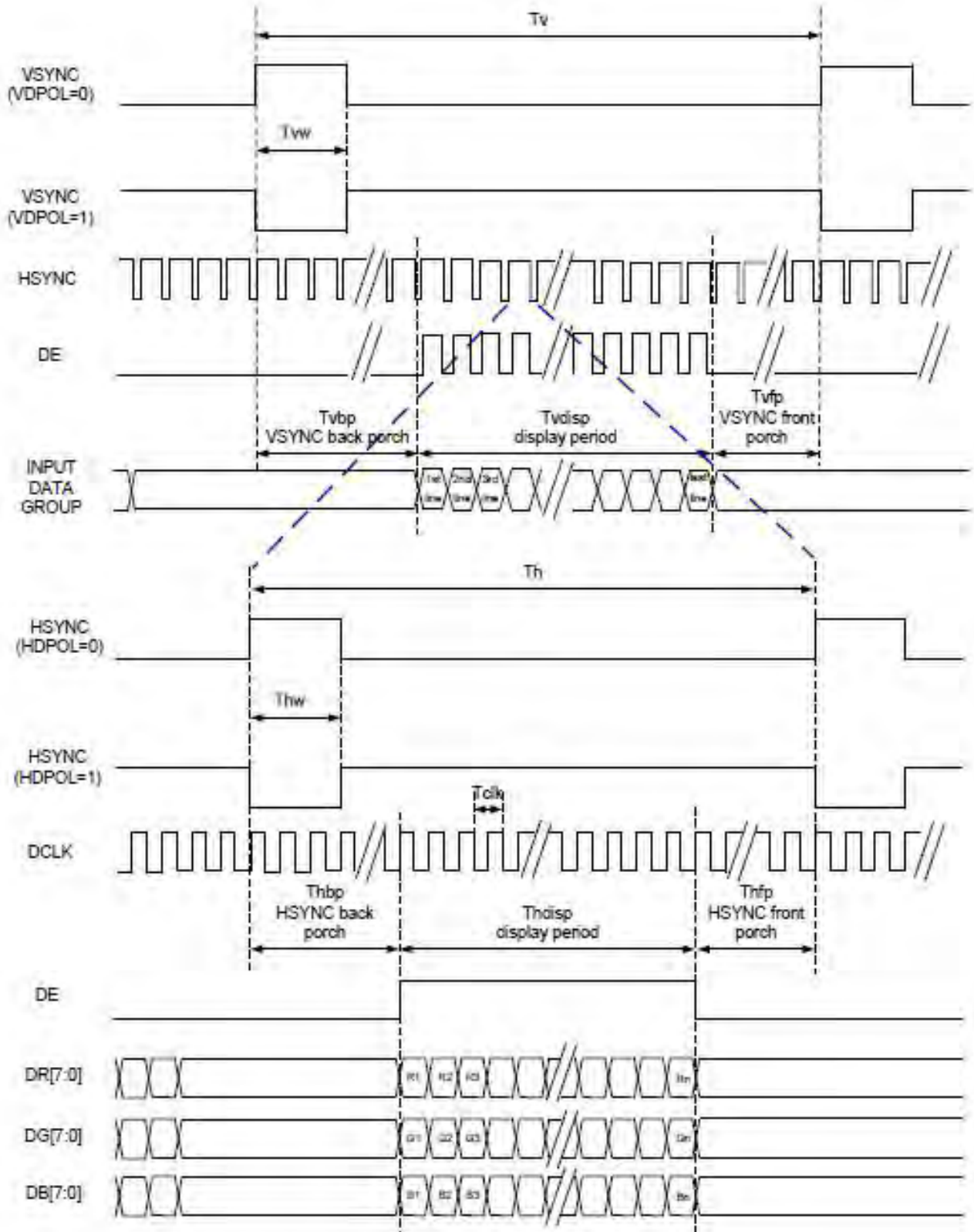

5.2.3 DE Mode

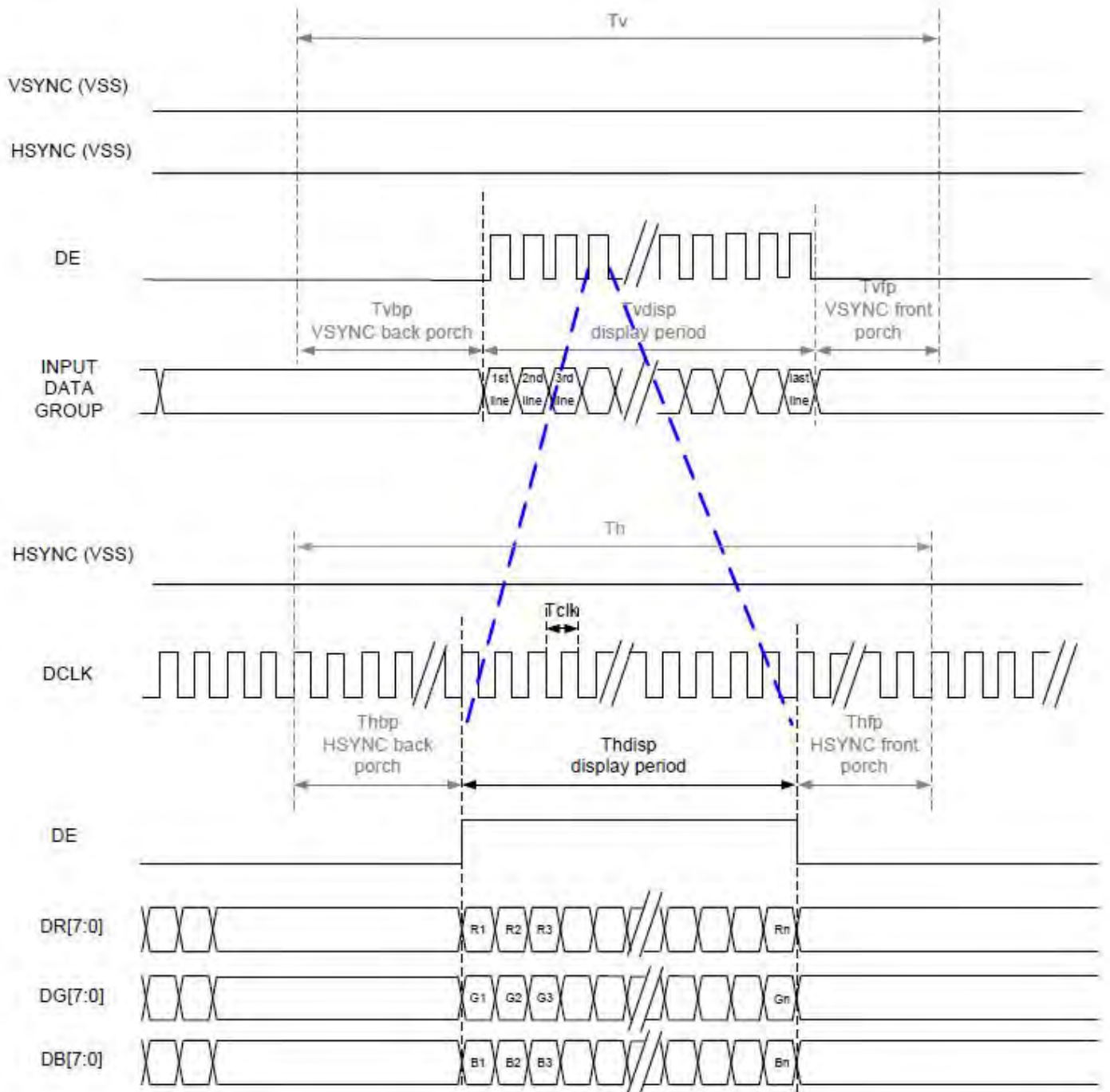

5.2.4 Parallel 24-bit RGB Input Timing Table

Parallel 24-bit RGB Input Timing (PVDD=VDD=VDDI= 3.3V, AGND= 0V, TA=25°C)

Parallel 24-bit RGB Interface Timing Table						
Item	Symbol	Min.	Typ.	Max.	Unit	Remark
DCLK Frequency	Fclk	17	20	23	MHz	
HSYNC	Period Time	Th	552	560	592	DCLK
	Display Period	Thdisp	544			DCLK
	Back Porch	Tbpb	8	16	24	DCLK
	Front Porch	Tbfp	8	16	24	DCLK
	Pulse Width	Thw	2	4	8	DCLK
VSYNC	Period Time	Tv	560	576	592	HSYNC
	Display Period	Tvdisp	544			HSYNC
	Back Porch	Tvbp	8	16	24	HSYNC
	Front Porch	Tvfp	8	16	24	HSYNC
	Pulse Width	Tvw	2	4	8	HSYNC

Note: 1. The minimum blanking time depends on the GIP timing of the panel specification

2. To ensure the compatibility of different panels, it is recommended to use the typical setting.

5.3 AC Characteristics

AC Electrical Characteristics (PVDD=VDD=VDDI= 3.3V, AGND= 0V, TA=25°C, Bare Chip)

5.3.1 System Operation AC Characteristics

DC Electrical Characteristics (PVDD=VDD=VDDI= 3.3V, AGND= 0V, TA=25°C, Bare Chip)

Item	Symbol	Min.	Typ.	Max.	Unit	Conditions
VDD Power Source Slew Time	TPOR	-	-	20	ms	From 0V to 99% VDD
GRB Pulse Width	tRSTW	10	50	-	us	R=10Kohm, C=1uF
SD Output Stable Time	Tst	-	-	12	us	Output settled within +20mV Loading = 6.8k+28.2pF.
GD Output Rise and Fall Time	Tgst	-	-	6	us	Output settled (5%~95%), Loading = 4.7k+29.8pF

5.3.2 System Bus Timing for RGB Interface

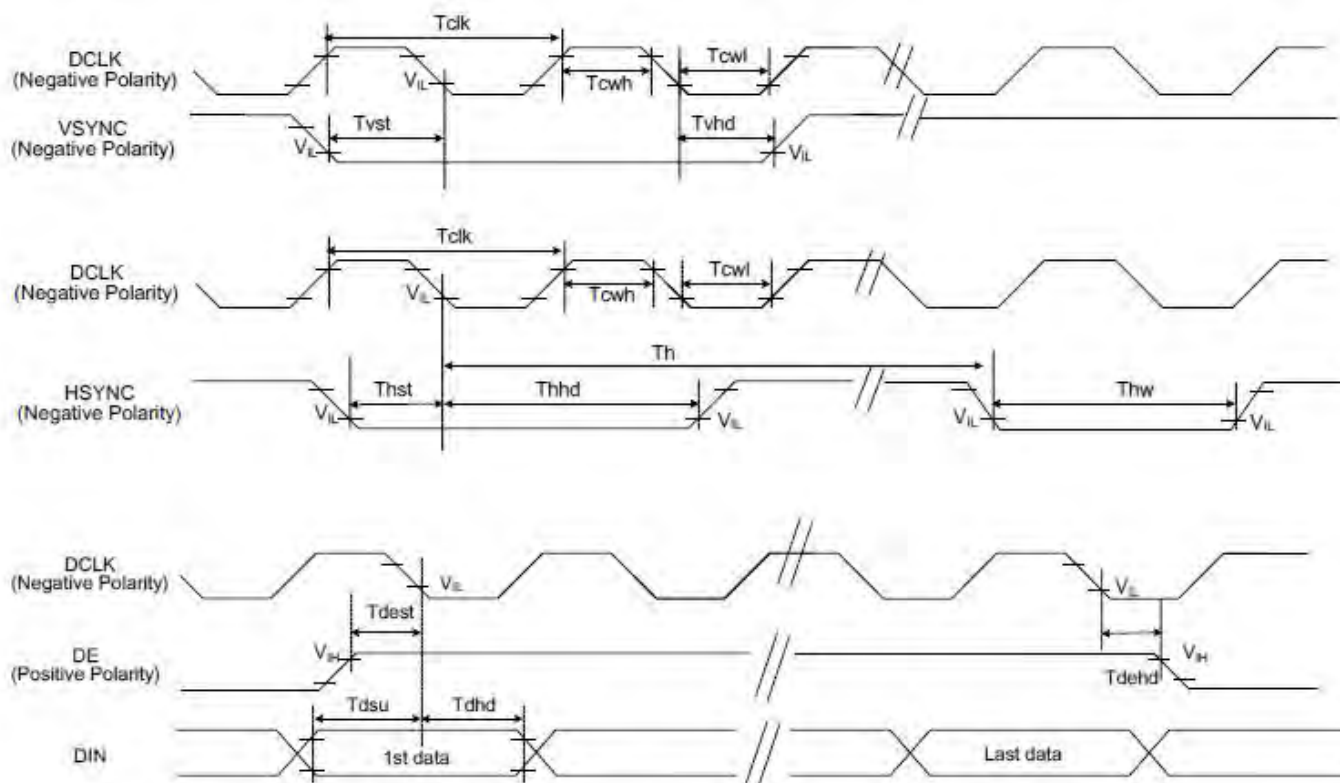

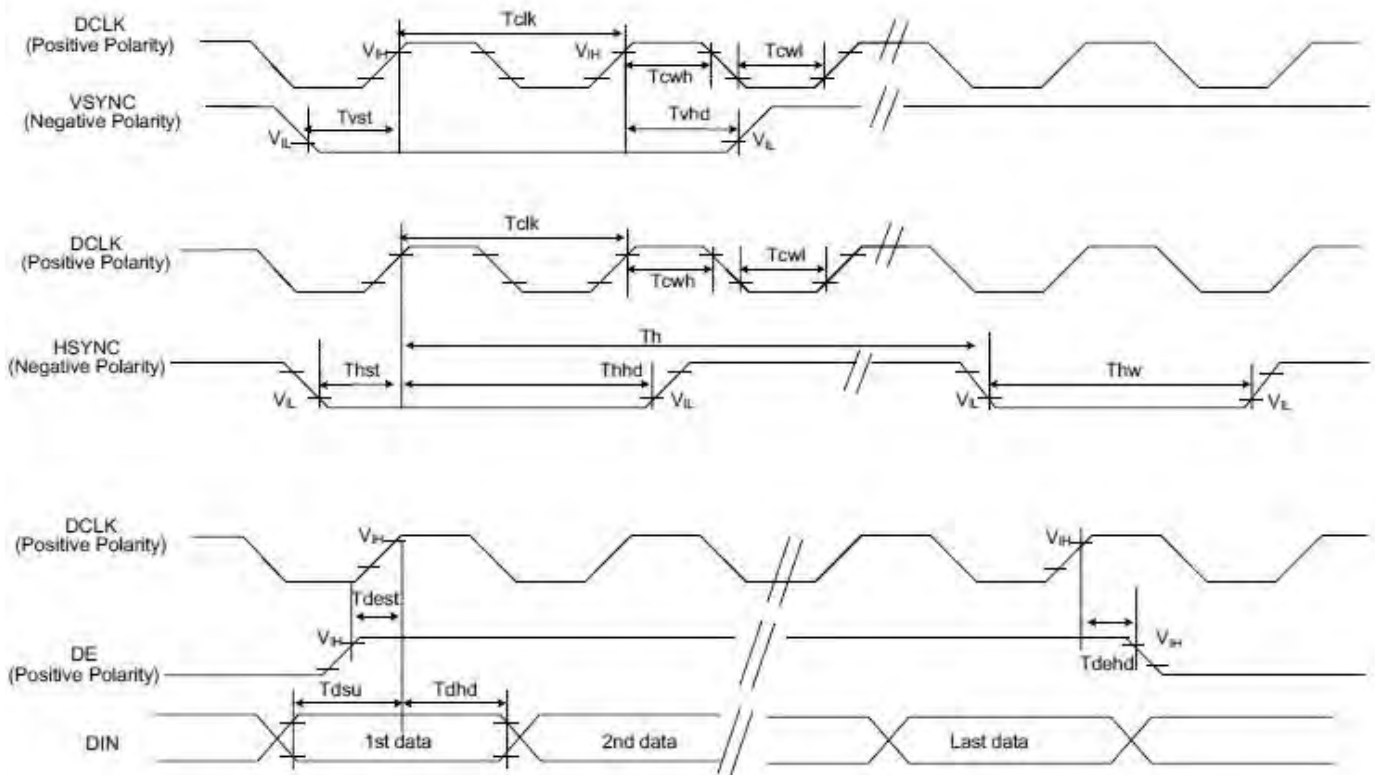

DC Electrical Characteristics (PVDD=VDD=VDDI= 3.3V, AGND= 0V, TA=25°C, Bare Chip)

Item	Symbol	Min.	Typ.	Max.	Unit	Conditions
CLK Pulse Duty	T_{cw}	40	50	60	%	
VSYNC Setup Time	T_{vst}	10	-	-	ns	
VSYNC Hold Time	T_{vhd}	10	-	-	ns	
HSYNC Setup Time	T_{hst}	10	-	-	ns	
HSYNC Hold Time	T_{hhd}	10	-	-	ns	
Data Setup Time	T_{dsu}	10	-	-	ns	
Data Hold Time	T_{dhd}	10	-	-	ns	
DE Setup Time	T_{dest}	10	-	-	ns	
DE Hold Time	T_{dehd}	10	-	-	ns	

6. Optical Specifications

Item	Symbol	Condition	Min.	Typ.	Max.	Unit	Note
Viewing Angle (CR≥10) B/L ON	θ_T	$\Phi=90^\circ$ (12 o'clock)	80	85	-	deg	Note2
	θ_B	$\Phi=270^\circ$ (6 o'clock)	80	85	-	deg	Note2
	θ_L	$\Phi=180^\circ$ (9 o'clock)	80	85	-	deg	Note2
	θ_R	$\Phi=0^\circ$ (3 o'clock)	80	85	-	deg	Note2
Response Time	T_{ON}	Normal $\theta=\Phi=0^\circ$	-	15	20	msec	Note4
	T_{OFF}		-	15	20	msec	Note4
Contrast Ratio	CR		1000	1200	-	-	Note1 Note3
Color Chromaticity	W_X		0.243	0.293	0.318	-	Note1 Note5
	W_Y		0.286	0.336	0.386	-	Note1 Note5
Luminance	L		900	1000	-	cd/m ²	Note1 Note7
Luminance Uniformity	Y_U		75	80	-	%	Note1 Note6
NTSC	-		55	60	-	%	-

Note 1: Definition of optical measurement system

The optical characteristics should be measured in dark room. After 5 minutes operation, the optical properties are measured at the center point of the LCD screen. All input terminals LCD panel must be ground when measuring the center area of the panel.

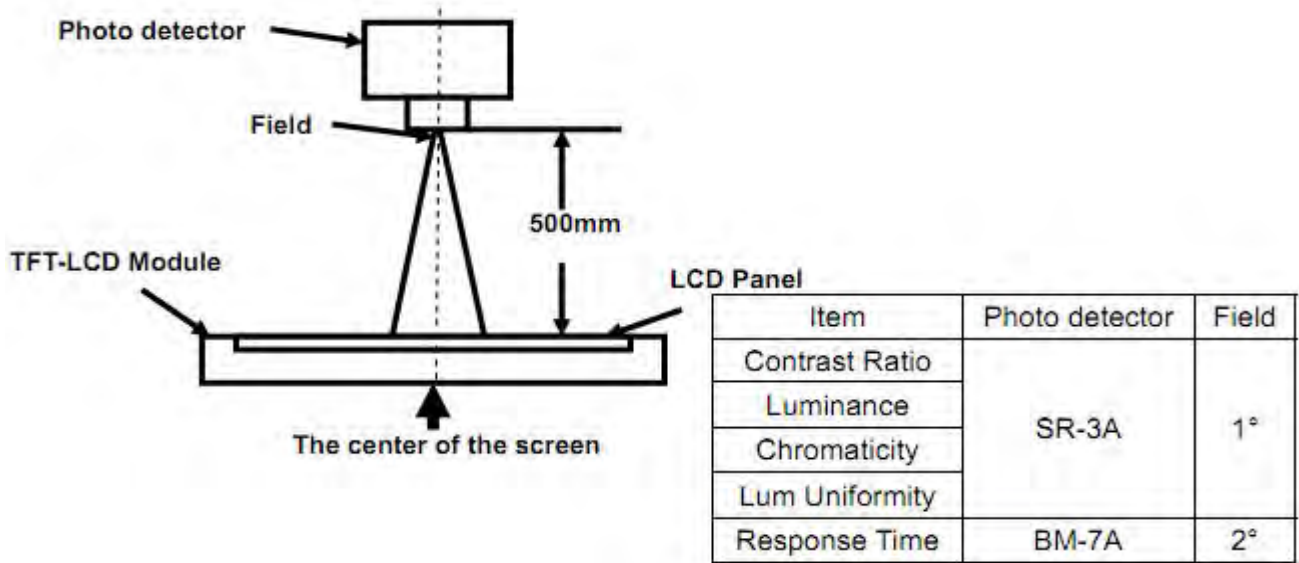

Note 2: Definition of viewing angle range and measurement system

Viewing angle is measured at the center point of the LCD by CONOSCOPE(ergo-80).

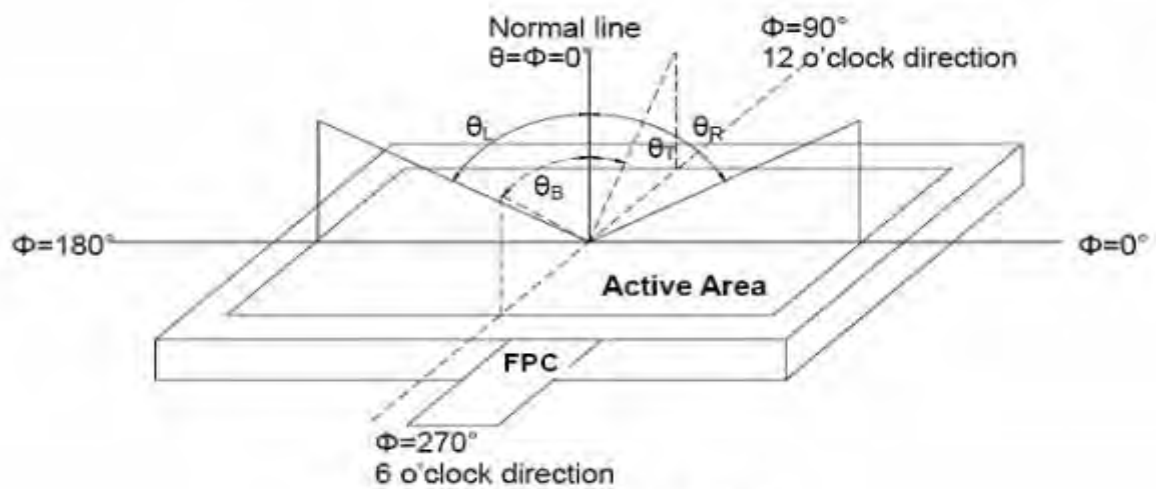

Fig. 1 Definition of viewing angle

Note 3: Definition of contrast ratio

$$CR = \frac{\text{Luminance with all pixels white}}{\text{Luminance with all pixels black}}$$

Note 4: Definition of Response time

The response time is defined as the LCD optical switching time interval between “White” state and “Black”state. Rise time (TON) is the time between photo detector output intensity changed from 90% to 10%. And fall time (TOFF) is the time between photo detector output intensity changed from 10% to 90%.

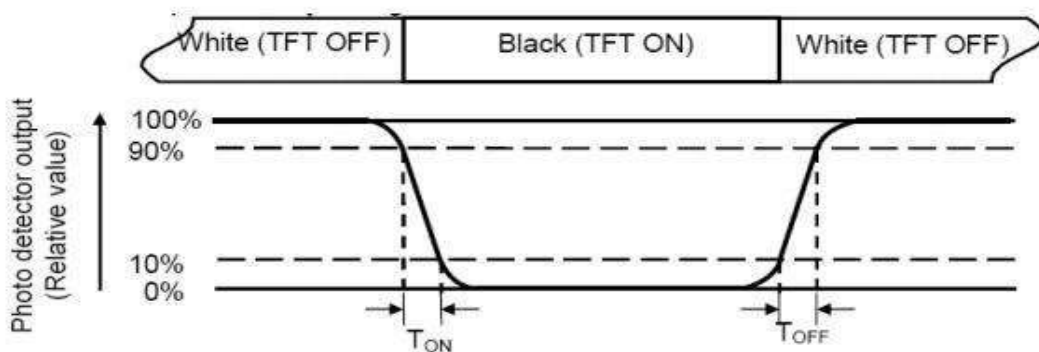

Note 5: Definition of color chromaticity (CIE1931)

Color coordinates measured at center point of LCD.

Note 6: Definition of Luminance Uniformity

The luminance uniformity in surface luminance is determined by measuring luminance at each test position 1 through n, and then dividing the maximum luminance of n points luminance by minimum luminance of n points luminance. For more information see FIG.2.

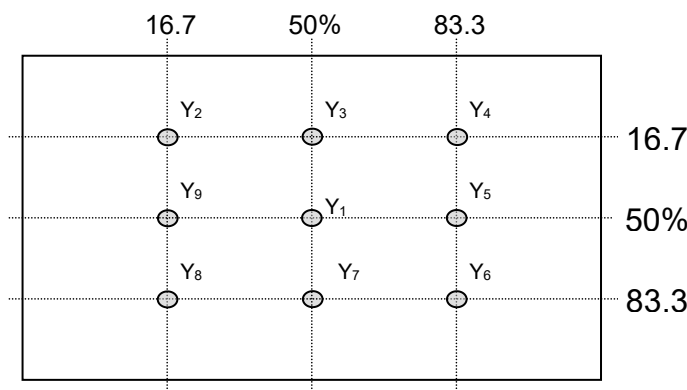

Fig. 2 Definition of points

Note 7: Definition of Luminance (Refer Fig. 2)

Surface luminance is the luminance with all pixels displaying white.

L_v = Average Surface Luminance with all white pixels($P_1, P_2, P_3, \dots, P_n$).

7. Reliability Test Items

Test Item	Test Conditions
High Temperature Storage	Ta= +85°C 96hrs
Low Temperature Storage	Ta= -30°C 96hrs
High Temperature Operation	Ta= +85°C 96hrs
Low Temperature Operation	Ta= -30°C 96hrs
High Temperature and Humidity Storage	Ta= +60°C, 90% RH 96hrs
Thermal Shock (Non-operation)	-30°C/30 min ~ +85°C/30 min for 20 cycles Start with cold temperature end with high temperature
Electro Static Discharge	Contact = ± 4 kV, class B Air = ± 8 kV, class B R=330Ω,C=150pF
Vibration	Sweep: 10Hz~55Hz~10Hz Stroke: 1.5mm 2 hrs for each direction of X .Y. Z.
Mechanical Shock	60G 6ms,±X,±Y,±Z 3 times for each direction
Package Drop Test	Height: 60 cm 1 corner, 3 edges, 6 surfaces

Notes: The test result shall be evaluated after the sample has been left at room temperature and humidity for 2 hours without load. No condensation shall be accepted. The sample will not be accepted if appear these defects:

- 1). Air bubble in the LCD
- 2). Seal leak or Glass crack
- 3). Non display or abnormal display
- 4). Brightness reduction >50%

8. Mechanical Drawing

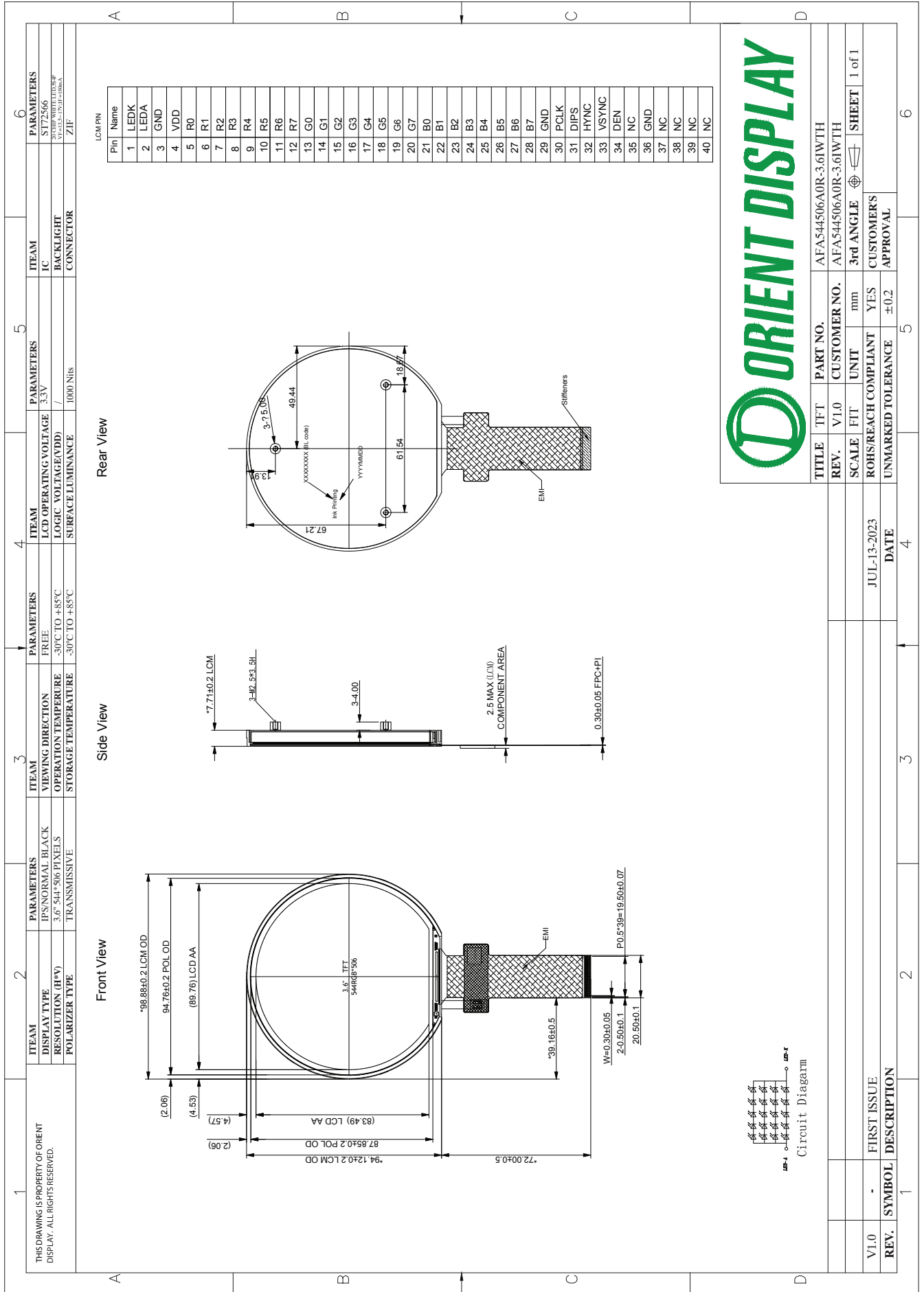

9. Packing

TBA

10. Precautions for Use of LCD modules

10.1 Handling Precautions

10.1.1. The display panel is made of glass. Do not subject it to a mechanical shock by dropping it from a high place, etc.

10.1.2. If the display panel is damaged and the liquid crystal substance inside it leaks out, be sure not to get any in your mouth, if the substance comes into contact with your skin or clothes, promptly wash it off using soap and water.

10.1.3. Do not apply excessive force to the display surface or the adjoining areas since this may cause the color tone to vary.

10.1.4. The polarizer covering the display surface of the LCD module is soft and easily scratched. Handle this polarizer carefully.

10.1.5. If the display surface is contaminated, breathe on the surface and gently wipe it with a soft dry cloth. If still not completely clear, moisten cloth with one of the following solvents:

- Isopropyl alcohol
- Ethyl alcohol

Solvents other than those mentioned above may damage the polarizer. Especially, do not use the following:

- Water
- Ketene
- Aromatic solvents

10.1.6. Do not attempt to disassemble the LCD Module.

10.1.7. If the logic circuit power is off, do not apply the input signals.

10.1.8. To prevent destruction of the elements by static electricity, be careful to maintain an optimum work environment.

10.1.8.1. Be sure to ground the body when handling the LCD Modules.

10.1.8.2. Tools required for assembly, such as soldering irons, must be properly ground.

10.1.8.3. To reduce the amount of static electricity generated, do not conduct assembly and other work under dry conditions.

10.1.8.4. The LCD Module is coated with a film to protect the display surface. Be care when peeling off this protective film since static electricity may be generated.

10.2 Storage Precautions

10.2.1. When storing the LCD modules, avoid exposure to direct sunlight or to the light of fluorescent lamps.

10.2.2. The LCD modules should be stored under the storage temperature range if the LCD modules will be stored for a long time, the recommend condition is :

Temperature : 0°C ~40°C Relatively humidity: ≤80%

10.2.3. The LCD modules should be stored in the room without acid, alkali and harmful gas.

10.3 Transportation Precautions

The LCD modules should be no falling and violent shocking during transportation, and also should avoid excessive press, water, damp and sunshine.