



**SPECIFICATION
FOR
LCD MODULE**

**MODULE NO: AFY240320B0-2.8N6NTM-SPI
REVISION NO: V01**

Customer's Approval:

--

	SIGNATURE	DATE
PREPARED BY (RD ENGINEER)		
CHECKED BY		
APPROVED BY		

Contents

1. General Specification	4
2. Mechanical Drawing	5
3. Block Diagram	6
4. Interface Pin Function	7
5. Absolute Maximum Ratings	8
6. Electrical Characteristics	10
7. Optical Characteristics	11
8. Timing Characteristics	14
9. Standard Specification for Reliability	16
10. Specification of Quality Assurance	18
11. Handling Precaution	27
12. Packing Method	28

1. General Specification

Item	Contents	Unit
LCD TYPE	TFT/TRANSMISSIVE	
MODULE SIZE (W*H*T)	50.00*69.20*2.45	MM
ACTIVE SIZE (W*H)	43.20*57.60	MM
PIXEL PITCH (W*H)	0.180*0.180	MM
NUMBER OF DOTS	240*320	
DRIVER IC	ILI9341V	
INTERFACE TYPE	4LINE SPI	
TOP POLARIZER TYPE	ANTI-GLARE	
RECOMMEND VIEWING DIRECTION	6	O'CLOCK
GRAY SCALE INVERSION DIRECTION	12	O'CLOCK
BACKLIGHT TYPE	4-DIES WHITE LED	
TOUCH PANEL TYPE	WITHOUT	

2. Mechanical Drawing

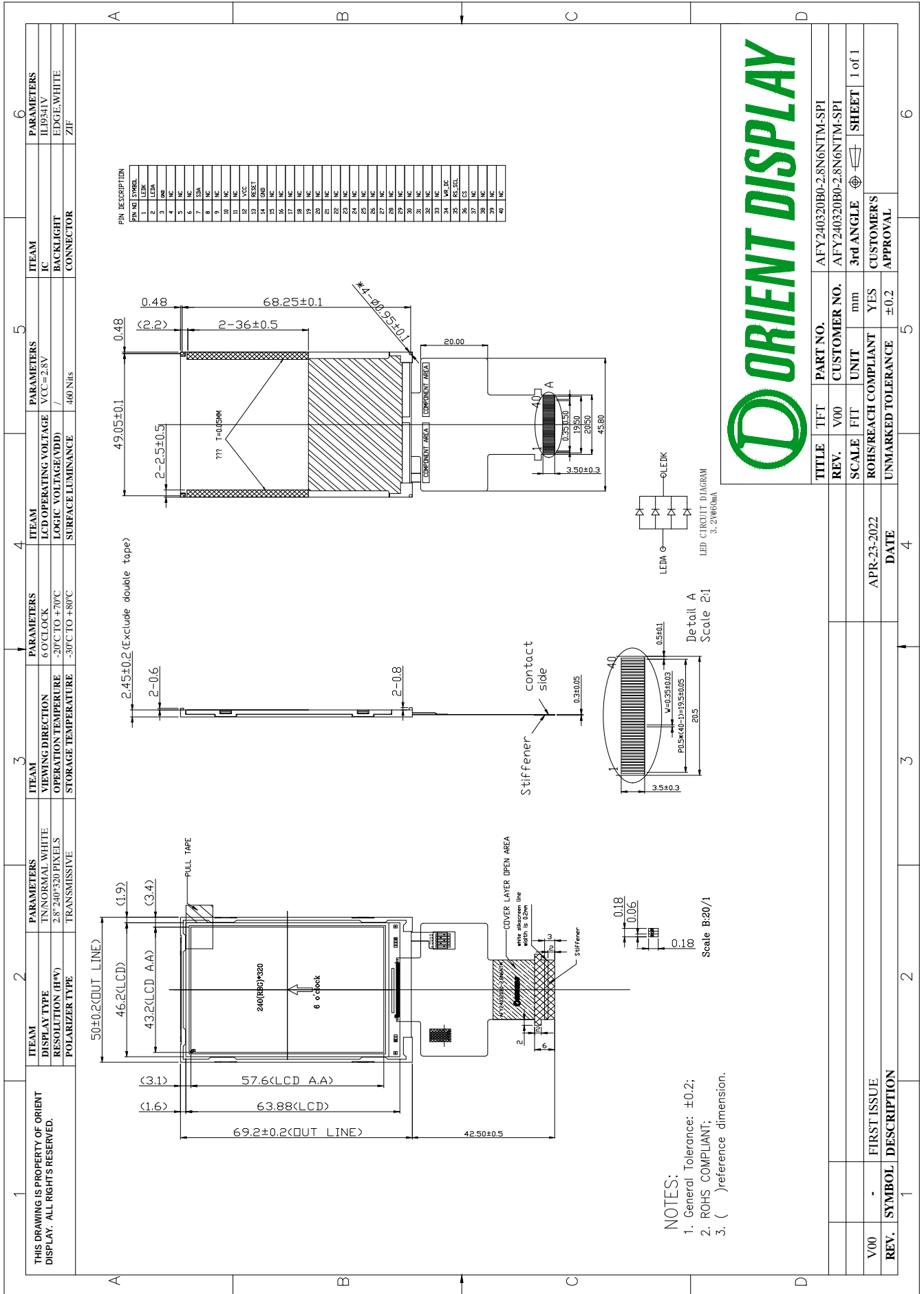

TITLE	TFT	PART NO.	AFY240320B0-2.8N6NTM-SPI	REV.	V00	CUSTOMER NO.	AFY240320B0-2.8N6NTM-SPI
SCALE	FIT	UNIT	mm	ROHS/REACH COMPLIANT	YES	CUSTOMER'S APPROVAL	APPROVAL
REV. SYMBOL		FIRST ISSUE		DATE	APR-23-2022	DATE	APR-23-2022
DESCRIPTION				UNMARKED TOLERANCE	±0.2	UNMARKED TOLERANCE	±0.2
				SHEET	1 of 1		

3. Block Diagram

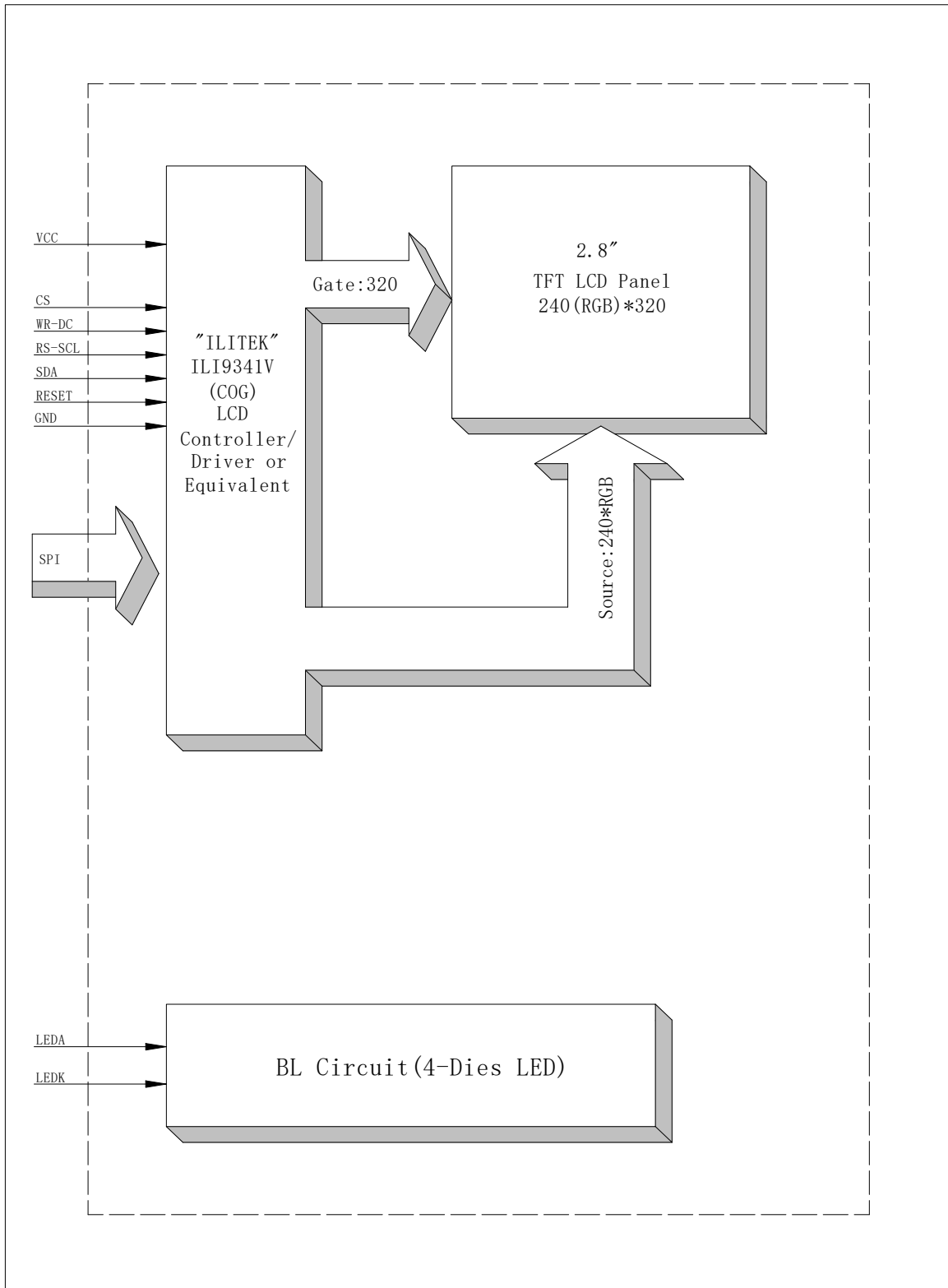

4. Interface Pin Function

Pin No.	Symbol	Description	Remark
1	LEDK	Cathode of LED backlight	
2	LEDA	Anode of LED backlight	
3	GND	Power ground	
4	NC	No connect	
5	NC	No connect	
6	NC	No connect	
7	SDA	Data input pin in serial interface	
8	NC	No connect	
9	NC	No connect	
10	NC	No connect	
11	NC	No connect	
12	VCC	Power supply	
13	RESET	Reset pin	
14	GND	Power ground	
15~32	NC	No connect	
33	NC	No connect	
34	WR DC	Serves as the selector of command or parameter	
35	RS SCL	Clock signal pin in serial interface	
36	CS	Chip select input pin (“Low” enable).	
37	XR/NC	No connect	
38	YD/NC	No connect	
39	XL/NC	No connect	
40	YU/NC	No connect	

5. Absolute Maximum Ratings

Parameter	Symbol	Min	Max	Unit
Supply voltage for analog	VCC	-0.3	4.6	V
Supply voltage for logic	VCC	-0.3	4.6	V
Supply current (One LED)	I _{LED}		30	mA
Operating temperature	T _{OP}	-20	+70	°C
Storage temperature	T _{ST}	-30	+80	°C

Note : The absolute maximum rating values of this product are not allowed to be exceeded at any times. Should a module be used with any of the absolute maximum ratings exceeded, the characteristics of the module may not be recovered, or in an extreme case, the module may be permanently destroyed.

6. Electrical Characteristics

6.1 Input Power

Item	Symbol	Min	Typ.	Max	Unit	Applicable terminal
Supply Voltage for Analog	VCC	2.5	2.8	3.3	V	
Supply Voltage for Logic	VCC	1.65	1.8/2.8	3.3	V	
Input Voltage	V _{IL}	GND	-	0.3VCC	V	
	V _{IH}	0.8 VCC	-	VCC		
Input leakage Current	I _{LKG}	-1		1	μA	

6.2 Backlight Driving Conditions

Item	Symbol	Value			Unit	Remark
		Min.	Typ.	Max.		
Voltage for LED Backlight	V _F	2.8	3.2	3.4	V	I _L =60mA
Current for LED Backlight	I _L		60	-	mA	
Power Consumption	P		0.192		W	
LED Life Time		30,000	50,000		Hr	Note

Note: Brightness to be decreased to 50% of the initial value at ambient temperature TA=25°C

7. Optical Characteristics

ITEM	SYMBOL	CONDITIONS	SPECIFICATIONS			UNIT	NOTE
			MIN	TYP.	MAX		
Luminance	L	$I_L = 60\text{mA}$	360	460	650	Cd/m^2	
Contrast Ratio	CR	$\theta = 0^\circ$	400	500			
Response Time	T_{ON}	25°C		20	30	ms	
	T_{OFF}						
CIE Color Coordinate	Red	X_R	Viewing normal angle	0.5934	0.6334	0.6734	
		Y_R		0.3036	0.3436	0.3836	
	Green	X_G		0.3053	0.3453	0.3853	
		Y_G		0.6001	0.6401	0.6801	
	Blue	X_B		0.1043	0.1443	0.1843	
		Y_B		0.0386	0.0786	0.1186	
	White	X_W		0.2682	0.3082	0.3482	
		Y_W		0.3223	0.3623	0.4023	
Viewing Angle	Hor.	θ_{X+}	$\text{CR} \geq 10$	60	70	Degree	
		θ_{X-}		60	70		
	Ver.	θ_{Y+}		60	70		
		θ_{Y-}		50	60		
Uniformity	Un			80		%	

Note 1: Definition of Viewing Angle θ_x and θ_y :

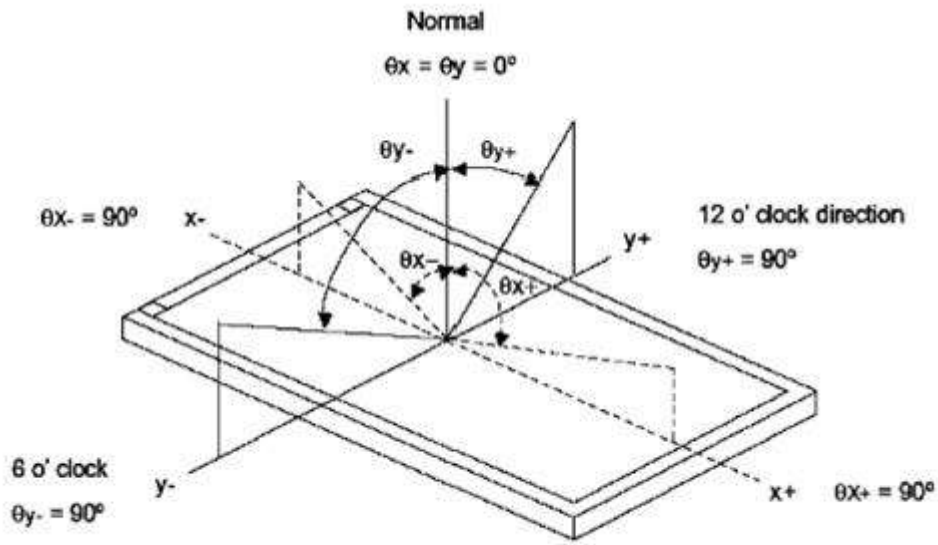

Note 2: Definition of contrast ratio CR:

$$CR = \frac{\text{Luminance of white state}}{\text{Luminance of black state}}$$

Note 3: Definition of Response Time (T_r, T_f)

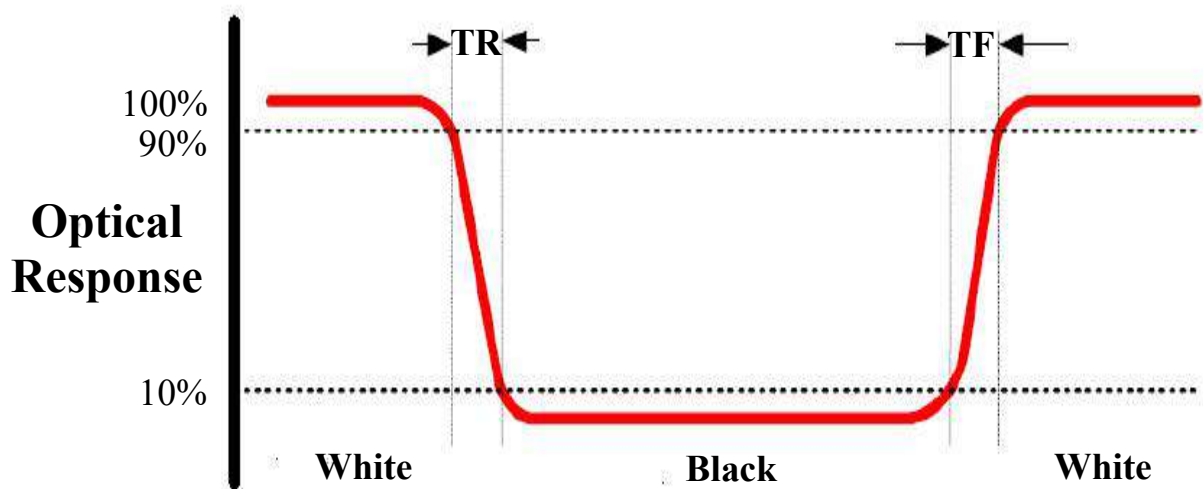

Note 4: Definition of Luminance

①The Brightness Test Equipment Setup

Field=2° (As measuring “black” image, field=2° is the best testing condition)

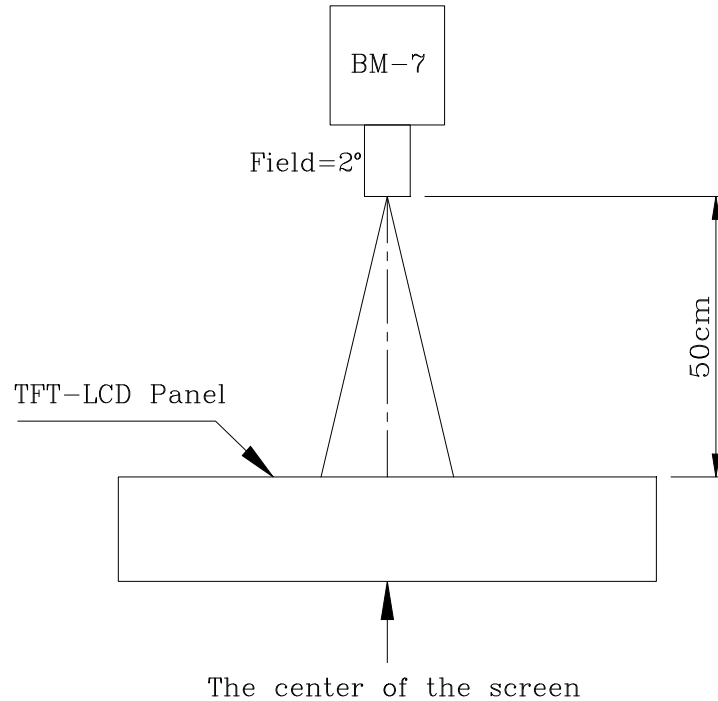

②The Brightness Test Point Setup

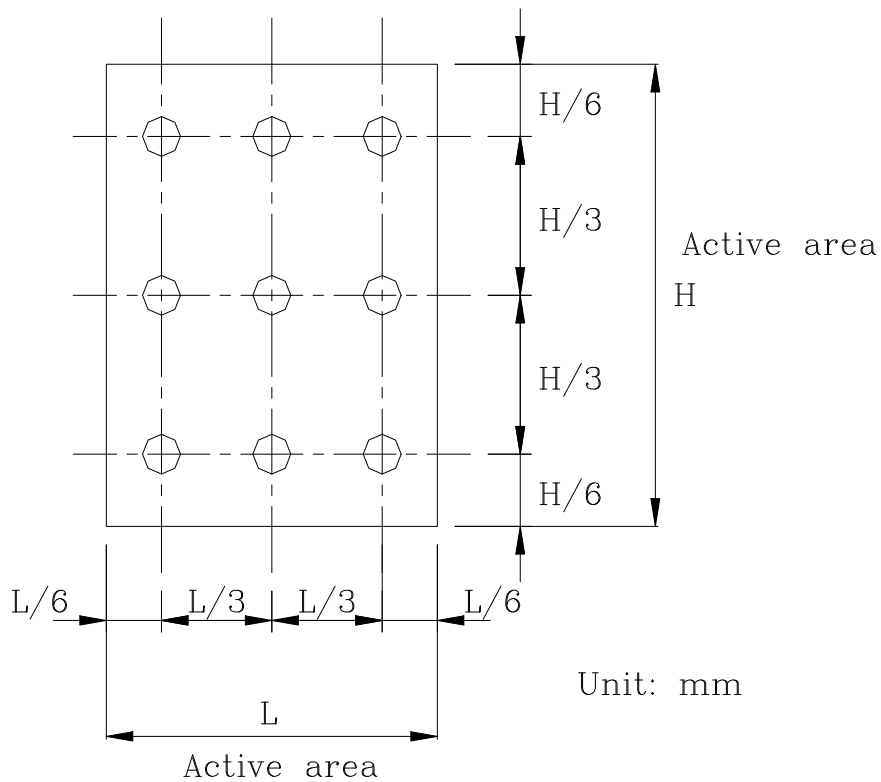

8. Timing Characteristics

8.1 Serial Interface Timing Characteristics (4-line SPI system)

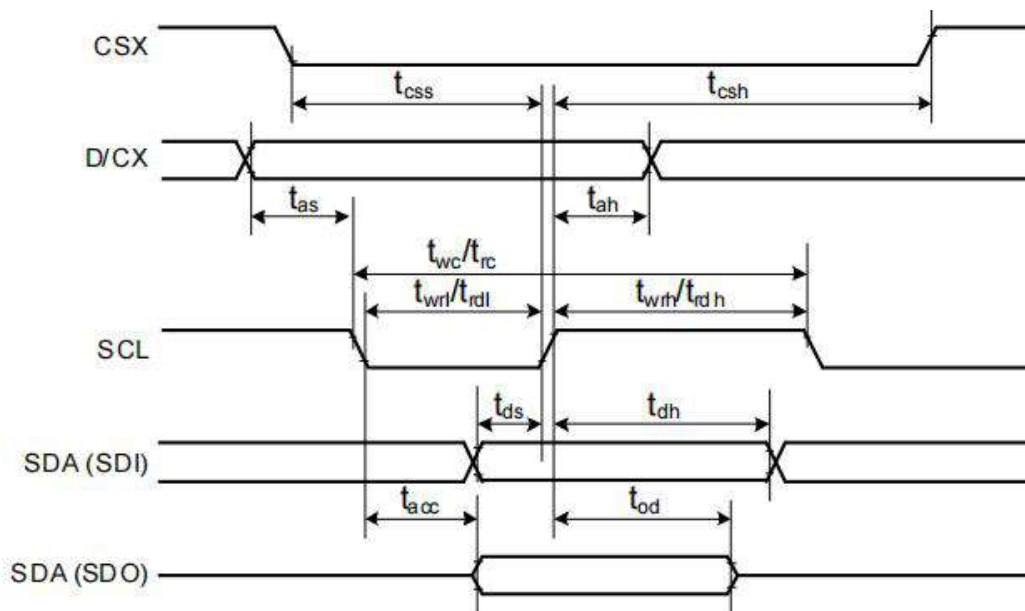

Signal	Symbol	Parameter	min	max	Unit	Description
CSX	t_{css}	Chip select time (Write)	40	-	ns	
	t_{csh}	Chip select hold time (Read)	40	-	ns	
SCL	t_{wc}	Serial clock cycle (Write)	100	-	ns	
	t_{wrh}	SCL "H" pulse width (Write)	40	-	ns	
	t_{wrl}	SCL "L" pulse width (Write)	40	-	ns	
	t_{rc}	Serial clock cycle (Read)	150	-	ns	
	t_{rdh}	SCL "H" pulse width (Read)	60	-	ns	
	t_{rdl}	SCL "L" pulse width (Read)	60	-	ns	
D/CX	t_{as}	D/CX setup time	10	-		
	t_{ah}	D/CX hold time (Write / Read)	10	-		
SDA / SDI (Input)	t_{ds}	Data setup time (Write)	30	-	ns	
	t_{dh}	Data hold time (Write)	30	-	ns	
SDA / SDO (Output)	t_{acc}	Access time (Read)	10	-	ns	For maximum CL=30pF
	t_{od}	Output disable time (Read)	10	50	ns	For minimum CL=8pF

Note: $T_a = 25\text{ }^\circ\text{C}$, $V_{DDI}=1.65\text{V to }3.3\text{V}$, $V_{CI}=2.5\text{V to }3.3\text{V}$, $AGND=VSS=0\text{V}$

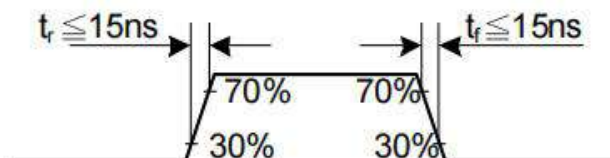

9. Standard Specification for Reliability

9.1 Standard Specification for Reliability of LCD Module

No.	Item	Description	Remarks
01	High temperature operation	The sample should be allowed to stand at 70°C for 240 hours under driving condition and then returning it to normal temperature condition, and allowing it stand for 2 hours.	Note 1 IEC60068-2-2, GB2423.2-89
02	Low temperature operation	The sample should be allowed to stand at -20°C for 240 hours under driving condition and then returning it to normal temperature condition, and allowing it stand for 2 hours.	Note2 IEC60068-2-1 GB2423.1-89
03	High temperature storage	The sample should be allowed to stand at 80°C for 240 hours under no-load condition, and then returning it to normal temperature condition, and allowing it stand for 2 hours.	IEC60068-2-2 GB2423.2-89
04	Low temperature storage	The sample should be allowed to stand at -30°C for 240 hours under no-load condition, then returning it to normal temperature condition, and allowing it stand for 2 hours.	IEC60068-2-1 GB/T2423.1-89
05	Moisture storage	The sample should be allowed to stand at 60°C,90%RH MAX for 240 hours under no-load condition, then taking it out and drying it at normal temperature for 2 hours.	IEC60068-2-1 GB/T2423.3-2006
06	Thermal shock storage	The sample should be allowed to stand the following 10 cycles : -20°C for 30 minutes → normal temperature for 5 minutes → +60°C for 30 minutes → normal temperature for 5 minutes, as one cycle.	Start with cold temperature,end with high temperature IEC60068-2-14, GB2423.22-87
07	Packing drop test	According to ASTM-D-5327.	IEC60068-2-32 GB/T2423.8-1995
08	Electrical Static Discharge	Air: ±4KV 150pF/330Ω 5 times	IEC61000-4-2 GB/T17626.2-1998
		Contact: ±2KV 150pF/330Ω 5 times	

- Note: 1. T_s is the temperature of panel's surface.
 2. T_a is the ambient temperature of sample.
 3. Sample size for each test item is 3~5pcs.

9.2 Testing Conditions and Inspection Criteria

For the final test, the testing sample must be stored at room temperature for 24 hours. After the tests listed in Table 9.2, standard specifications for reliability will be executed in order to ensure stability.

No.	Item	Test Model	In section Criteria
01	Current Consumption	Refer To Specification	The current consumption should conform to the product specification.
02	Contrast	Refer To Specification	After the tests have been executed, the contrast must be larger than half of its initial value prior to the tests.
03	Appearance	Visual inspection	Defect free.

9.3 MTBF

MTBF	Functions, performance, appearance, etc. shall be free from remarkable deterioration within 50,000 hours under ordinary operating and storage conditions room temperature ($25\pm 5^{\circ}\text{C}$), normal humidity ($50\pm 10\%$ RH), and in area not exposed to direct sun light.
------	---

10. Specification of Quality Assurance

This standard of Quality Assurance confirms to the quality of LCD module products supplied by ODNA.

10.1 Quality Test

Before delivering, the supplier should conduct the following tests to confirm the quality of products.

- Electrical-Optical Characteristics: According to the individual specification to test the product.
- Appearance Characteristics: According to the individual specification to test the product.
- Reliability Characteristics: According to the definition of reliability on the specification for testing products.

10.2 Delivery Test

Before delivering, the supplier should conduct the delivery test.

- Test method: According to MIL-STD105E.General Inspection Level II take a single Time.
- The defects classify of AQL as following:
Major defect: AQL = 0.65
Minor defect: AQL = 2.5
Total defects: AQL = 2.5

10.3 Non-conforming Analysis & Deal With Manners

10.3.1 Non-conforming Analysis

- Purchaser should provide the data detail of non-conforming sample and the non-conforming.
- After receiving the data detail from purchaser, the analysis of non-conforming should be finished within two weeks.
- If the analysis can't be finished on time, supplier must notice purchaser 3 days in advance.

10.3.2 Disposition of non-conforming

- If any product defect be found during assembling, supplier must change the good for every defect after confirmation.
- Both supplier and customer should analyze the reason and discuss the disposition of non-conforming when the reason of nonconforming is not sure.

10.4 Agreement items

Both parties should negotiate together when the following problems happen.

- There is any problem of standard of quality assurance, and both sides should agree that it must be modified.
- There is any argument item which does not record in the standard of quality assurance.
- Any other special problem.

10.5 Standard of The Product Appearance Test

10.5.1 Manner of appearance test

- The test must be under 20W × 2 or 40W fluorescent light, and the distance of view must be at 30±5cm.
- When test the model of transmissive product must add the reflective plate.
- The test direction is base on around 10° of vertical line.
- Temperature: 25±5°C Humidity: 60±10%RH

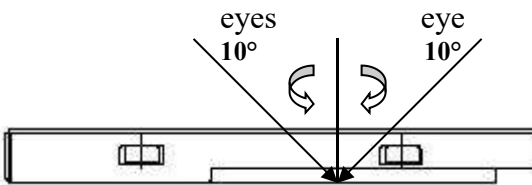

- Definition of area:

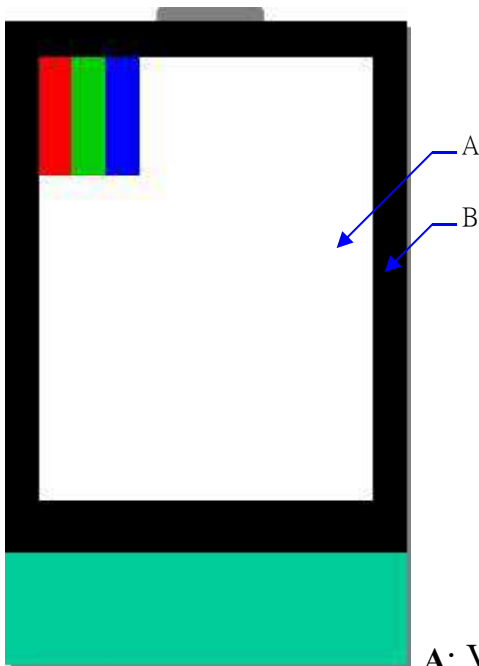

A: Viewing area B: Outside viewing area

10.5.2 Basic principle

- When the standard can not be described, AQL will be applied.
- The sample of the lowest acceptable quality level must be negotiated by both supplier and customer when any dispute happened.
- New item must be added on time when it is necessary.

10.6 Inspection Specification

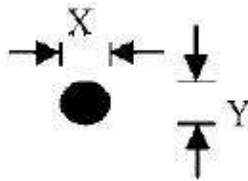
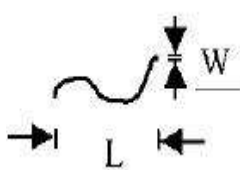
NO.	Item	Criterion	AQL												
01	Electrical Testing	1.1 Missing vertical, horizontal segment, segment contrast defect. 1.2 Missing character, dot or icon. 1.3 Display malfunction. 1.4 No function or no display. 1.5 Current consumption exceeds product specifications. 1.6 LCD viewing angle defect. 1.7 Mixed product types. 1.8 Flicker	0.65												
02	Black or White spots or Bright spots or Color spots on LCD (Display only)	2.1 White and black or color spots on display $\cong 0.25\text{mm}$, no more than Five spots. 2.2 Densely spaced: No more than three spots within 3mm.	2.5												
03	LCD and Touch Panel black spots, white spots, contamination (non – display)	3.1 Round type: As following drawing $\Phi = (X+Y) / 2$  <table border="1" data-bbox="821 1131 1348 1377"> <thead> <tr> <th>Size(mm)</th> <th>Acceptable Q'ty</th> </tr> </thead> <tbody> <tr> <td>$\Phi \cong 0.10$</td> <td>Accept no dense</td> </tr> <tr> <td>$0.10 < \Phi \cong 0.20$</td> <td>2</td> </tr> <tr> <td>$0.20 < \Phi \cong 0.25$</td> <td>2</td> </tr> <tr> <td>$0.25 < \Phi \cong 0.30$</td> <td>1</td> </tr> <tr> <td>$0.30 < \Phi$</td> <td>0</td> </tr> </tbody> </table> <p>* Densely spaced: No more than two spots within 3mm.</p>	Size(mm)	Acceptable Q'ty	$\Phi \cong 0.10$	Accept no dense	$0.10 < \Phi \cong 0.20$	2	$0.20 < \Phi \cong 0.25$	2	$0.25 < \Phi \cong 0.30$	1	$0.30 < \Phi$	0	2.5
		Size(mm)	Acceptable Q'ty												
$\Phi \cong 0.10$	Accept no dense														
$0.10 < \Phi \cong 0.20$	2														
$0.20 < \Phi \cong 0.25$	2														
$0.25 < \Phi \cong 0.30$	1														
$0.30 < \Phi$	0														
3.2 Line type: (As following drawing)  <table border="1" data-bbox="726 1534 1348 1803"> <thead> <tr> <th>Length(mm)</th> <th>Width(mm)</th> <th>Acceptable Q'ty</th> </tr> </thead> <tbody> <tr> <td>---</td> <td>$W \cong 0.02$</td> <td>Accept no dense</td> </tr> <tr> <td>$L \cong 3.0$</td> <td>$0.02 < W \cong 0.05$</td> <td rowspan="2">2</td> </tr> <tr> <td>$L \cong 2.5$</td> <td>$0.03 < W \cong 0.08$</td> </tr> <tr> <td>---</td> <td>$0.08 < W$</td> <td>Rejection</td> </tr> </tbody> </table> <p>* Densely spaced: No more than two lines within 3mm.</p>	Length(mm)	Width(mm)	Acceptable Q'ty	---	$W \cong 0.02$	Accept no dense	$L \cong 3.0$	$0.02 < W \cong 0.05$	2	$L \cong 2.5$	$0.03 < W \cong 0.08$	---	$0.08 < W$	Rejection	2.5
Length(mm)	Width(mm)	Acceptable Q'ty													
---	$W \cong 0.02$	Accept no dense													
$L \cong 3.0$	$0.02 < W \cong 0.05$	2													
$L \cong 2.5$	$0.03 < W \cong 0.08$														
---	$0.08 < W$	Rejection													

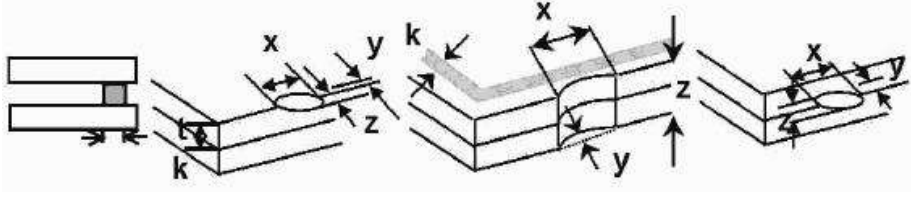
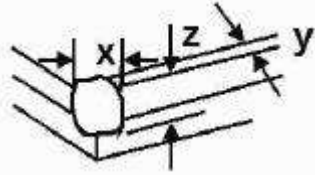
NO.	Item	Criterion			AQL	
04	Polarizer bubbles	If bubbles are visible, judge using black spot specifications, not easy to find, must check in specify direction	Size Φ (mm)	Acceptable Q'ty	2.5	
			$\Phi \leq 0.20$	Accept no dense		
			$0.20 < \Phi \leq 0.50$	3		
			$0.50 < \Phi \leq 1.00$	2		
			$1.00 < \Phi$	0		
			Total Q'ty	3		
05	Scratches	Follow NO.3 -2 Line Type.				
06	Chipped glass	Symbols: x: Chip length y: Chip width z: Chip thickness k: Seal width t: Glass thickness a: LCD side length L: Electrode pad length 6.1 General glass chip: 6.1.1 Chip on panel surface and crack between panels:				2.5
			z: Chip thickness	y: Chip width	x: Chip length	
			$Z \leq 1/2t$	Not over viewing area	$x \leq 1/8a$	
			$1/2t < z \leq 2t$	Not exceed 1/3k	$x \leq 1/8a$	
			⊙ Unit: mm			
			⊙ If there are 2 or more chips, x is the total length of each chip			
6.1.2 Corner crack:				2.5		
z: Chip thickness	y: Chip width	x: Chip length				
$Z \leq 1/2t$	Not over viewing area	$x \leq 1/8a$				
$1/2t < z \leq 2t$	Not exceed 1/3k	$x \leq 1/8a$				
⊙ Unit: mm						
⊙ If there are 2 or more chips, x is the total length of each chip						

NO.	Item	Criterion	AQL
08	Cracked glass	The LCD with extensive crack is not acceptable.	2.5
09	Backlight elements	9.1 Illumination source flickers when lit. 9.2 Spots or scratches that appear when lit must be judged. Using LCD spot, lines and contamination standards. 9.3 Backlight doesn't light or color is wrong.	2.5 2.5 0.65
10	Bezel	Bezel must comply with product specifications.	2.5
11	PCB、COB	11.1 COB seal may not have pinholes larger than 0.2mm or contamination. 11.2 COB seal surface may not have pinholes through to the IC. 11.3 The height of the COB should not exceed the height indicated in the assembly diagram. 11.4 There may not be more than 2mm of sealant outside the seal area on PCB. And there should be no more than three places. 11.5 Parts on PCB must be the same as on the production characteristic chart, There should be no wrong parts, missing parts or excess parts. 11.6 The jumper on the PCB should conform to the product characteristic chart.	2.5 2.5 2.5 2.5 0.65 0.65
12	FPC	12.1 FPC terminal damage \cong 1/2 FPC terminal width and can not affect the function , we judge accept. 12.2 FPC alignment hole damage \cong 1/2 alignment area and can not affect the function , we judge accept.	2.5 2.5
13	Soldering	13.1 No cold solder joints, missing solder connections, oxidation or icicle. 13.2 No short circuits in components on PCB or FPC.	2.5 0.65

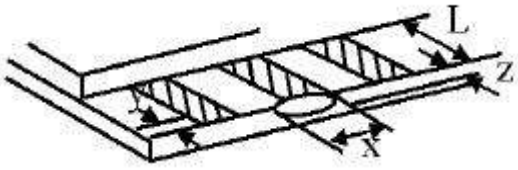
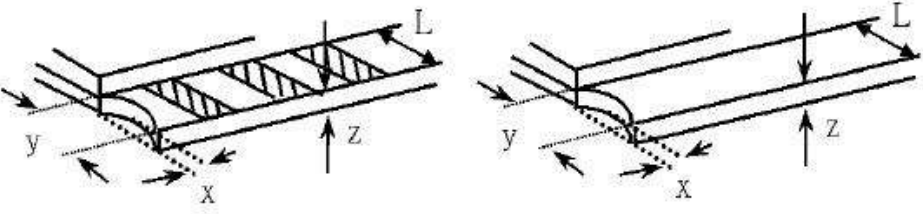
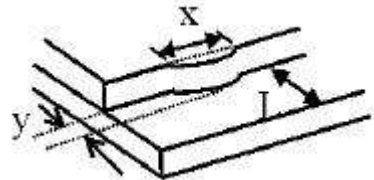
NO.	Item	Criterion	AQL																
07	Glass crack	<p>Symbols: x: Chip length y: Chip width z: Chip thickness k: Seal width t: Glass thickness a: LCD side length L: Electrode pad length</p> <p>7.2 Protrusion over terminal: 7.2.1 Chip on electrode pad:</p>  <table border="1" data-bbox="558 761 1236 907"> <tr> <td>y: Chip width</td> <td>x: Chip length</td> <td>z: Chip thickness</td> </tr> <tr> <td>$y \leq 0.5\text{mm}$</td> <td>$x \leq 1/8a$</td> <td>$0 < z \leq t$</td> </tr> </table> <p>7.2.2 Non-conductive portion:</p>  <table border="1" data-bbox="558 1276 1236 1422"> <tr> <td>y: Chip width</td> <td>x: Chip length</td> <td>z: Chip thickness</td> </tr> <tr> <td>$y \leq L$</td> <td>$x \leq 1/8a$</td> <td>$0 < z \leq t$</td> </tr> </table> <p>⊙ If there chipped area touches the ITO terminal, over 2/3 of the ITO must remain and be inspected according to electrode terminal specifications. ⊙ If the product will be heat sealed by the customer, the alignment mark must not be damaged.</p> <p>7.2.3 Substrate protuberance and internal crack</p>  <table border="1" data-bbox="885 1747 1324 1892"> <tr> <td>y: width</td> <td>x: length</td> </tr> <tr> <td>$y \leq 1/3L$</td> <td>$X \leq a$</td> </tr> </table>	y: Chip width	x: Chip length	z: Chip thickness	$y \leq 0.5\text{mm}$	$x \leq 1/8a$	$0 < z \leq t$	y: Chip width	x: Chip length	z: Chip thickness	$y \leq L$	$x \leq 1/8a$	$0 < z \leq t$	y: width	x: length	$y \leq 1/3L$	$X \leq a$	2.5
y: Chip width	x: Chip length	z: Chip thickness																	
$y \leq 0.5\text{mm}$	$x \leq 1/8a$	$0 < z \leq t$																	
y: Chip width	x: Chip length	z: Chip thickness																	
$y \leq L$	$x \leq 1/8a$	$0 < z \leq t$																	
y: width	x: length																		
$y \leq 1/3L$	$X \leq a$																		

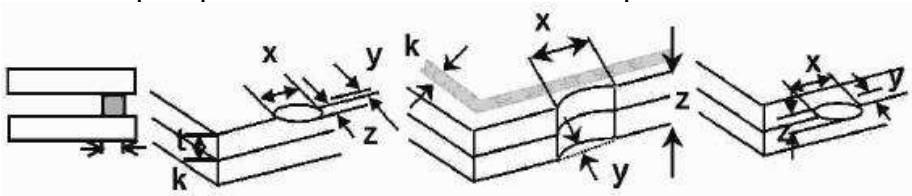
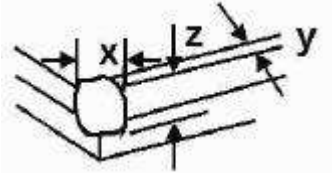
NO.	Item	Criterion	AQL												
14	Touch Panel Chipped glass	<p>Symbols: x: Chip length y: Chip width z: Chip thickness k: Seal width t: Touch Panel Total thickness a: LCD side length L: Electrode pad length</p> <p>14.1 General glass chip: 14.1.1 Chip on panel surface and crack between panels:</p>  <table border="1" data-bbox="451 763 1270 981"> <tr> <td>z: Chip thickness</td> <td>y: Chip width</td> <td>x: Chip length</td> </tr> <tr> <td>$Z \leq t$</td> <td>$\cong 1/2 k$ and not over viewing area</td> <td>$x \leq 1/8a$</td> </tr> </table> <p>⊙ Unit: mm ⊙ If there are 2 or more chips, x is the total length of each chip</p> <p>14.1.2 Corner crack:</p>  <table border="1" data-bbox="451 1361 1270 1579"> <tr> <td>z: Chip thickness</td> <td>y: Chip width</td> <td>x: Chip length</td> </tr> <tr> <td>$z \leq t$</td> <td>$\cong 1/2 k$ and not over viewing area</td> <td>$x \leq 1/8a$</td> </tr> </table> <p>⊙ Unit: mm ⊙ If there are 2 or more chips, x is the total length of each chip</p>	z: Chip thickness	y: Chip width	x: Chip length	$Z \leq t$	$\cong 1/2 k$ and not over viewing area	$x \leq 1/8a$	z: Chip thickness	y: Chip width	x: Chip length	$z \leq t$	$\cong 1/2 k$ and not over viewing area	$x \leq 1/8a$	2.5
z: Chip thickness	y: Chip width	x: Chip length													
$Z \leq t$	$\cong 1/2 k$ and not over viewing area	$x \leq 1/8a$													
z: Chip thickness	y: Chip width	x: Chip length													
$z \leq t$	$\cong 1/2 k$ and not over viewing area	$x \leq 1/8a$													

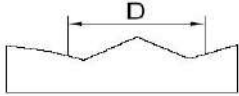
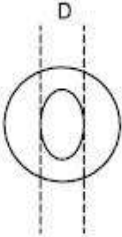
NO.	Item	Criterion	AQL										
15	Touch Panel(Fish eye、dent and bubble on film)	<table border="1" data-bbox="459 320 987 524"> <thead> <tr> <th>SIZE(mm)</th> <th>Acceptable Q'ty</th> </tr> </thead> <tbody> <tr> <td>$\Phi \leq 0.2$</td> <td>Accept no dense</td> </tr> <tr> <td>$0.2 < D \leq 0.4$</td> <td>5</td> </tr> <tr> <td>$0.4 < D \leq 0.5$</td> <td>2</td> </tr> <tr> <td>$0.5 < D$</td> <td>0</td> </tr> </tbody> </table>  	SIZE(mm)	Acceptable Q'ty	$\Phi \leq 0.2$	Accept no dense	$0.2 < D \leq 0.4$	5	$0.4 < D \leq 0.5$	2	$0.5 < D$	0	2.5
SIZE(mm)	Acceptable Q'ty												
$\Phi \leq 0.2$	Accept no dense												
$0.2 < D \leq 0.4$	5												
$0.4 < D \leq 0.5$	2												
$0.5 < D$	0												
16	Touch Panel Newton ring	Newton ring dimension $\leq 1/2$ touch panel area and not affect font and line distortion($\leq 2.5\%$) , it is acceptable.	2.5										
17	Touch Panel Linearity	Less than 2.5% is acceptable.	2.5										
18	LCD Ripple	Touch the touch panel , can not see the LCD ripple. Pen: R 1.0mm silicon rubber. Operation Force: 80g	2.5										
19	General appearance	<p>19.1 Pin type must match type in specification sheet.</p> <p>19.2 LCD pin loose or missing pins.</p> <p>19.3 Product packaging must the same as specified on packaging specification sheet.</p> <p>19.4 Product dimension and structure must conform to product specification sheet.</p>	<p>0.65</p> <p>0.65</p> <p>0.65</p> <p>0.65</p>										

11. Handling Precaution

11.1 Handling of LCM

- Avoid external shock.
- Don't apply excessive force on the surface.
- Liquid in LCD is hazardous substance, do not lick or swallow. When the liquid is attaching to your hand, skin, cloth, etc., wash it thoroughly and immediately.
- Don't operate it above the absolute maximum rating.
- Don't disassemble the LCM.
- The operators should wear protections whenever he/she comes into contact with the module. Never touch any of the conductive parts such as the LSI pads, the copper leads on the PCB and the interface terminals with any parts of the human body.
- The modules should be kept in antistatic bags or other containers resistant to static for storage.
- The module is coated with a film to protect the display surface, be careful when peeling off this protective film since static electricity may be generated.

11.2 Storage

- Store it in an ambient temperature of $25\pm 10^{\circ}\text{C}$, and in a relative humidity of $50\pm 10\%\text{RH}$. Don't expose to sunlight or fluorescent light.
- Store it in a clean environment, free from dust, active gas, and solvent.
- Store it in anti-static electricity container.
- Store it without any physical load.

11.3 Soldering

- Use only soldering irons with proper grounding and no leakage.
- Iron: no higher than $280\pm 10^{\circ}\text{C}$ and less than 3 sec during hand soldering.
- Rewiring: no more than 2 times.

12. Packing Method

No.	Item	Dimensions(mm)	Quantity	Remark
1	LCM Module	50.00*69.20*2.45	240PCS	
2	TRAY	388*347*20 (include 15pcs products/one tray)	17PCS	
3	CARTON	405*355*250 (include 240pcs products/one carton)	1PCS	