

SPECIFICATION FOR APPROVAL

Customer: 深圳市鸿智电子技术有限公司

Customer P/N: _____

Wenrun Model: WR-PB1608UY-L09

Description: SMD 0603 黄光

Prepared By: Andy

Checkedy: _____

Customer Confirmation



WENRUN OPTOELECTRONIC

TEL:0755-29601122 FAX:0755-29601133

深圳: 深圳福永怀德咸田三区富德商务大厦 1022 室

江苏: 江苏省镇江市丁卯开发区纬一路 88 号

[Http://www.wenrun.com](http://www.wenrun.com)

NO.:091100000

Part No.	WR-PB1608UY-L09		
Emitted Color	High Super Yellow	Len's Color	Water Clear
Chip Material	AlGaInP		

◆ Features:

Compatible with automatic placement equipment
 Compatible with reflow solder process
 Low power consumption and wide viewing angle
 This product doesn't contain restriction Substance, comply ROHS standard.

◆ Applications:

Automotive and Telecommunication
 Flat backlight for LCD ,switch and symbol in telephone and fax
 General use for indicators

◆ Package Dimensions:

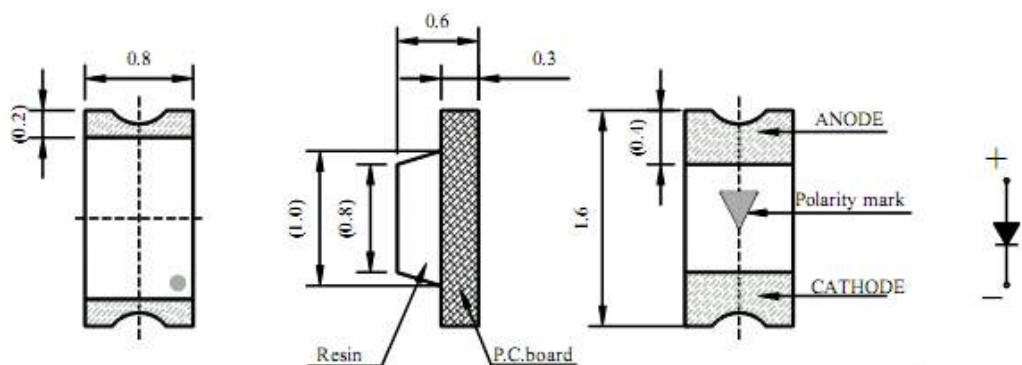

Unit : mm
 Tolerance:± 0.1

Electrodes: Au Plating
 Encapsulating Resin: Epoxy Resin
 Package: BT Resin

◆ Absolute Maximum Rating (Ta=25℃)

Parameter	Symbol	Max.	Unit
Power Dissipation	P_M	70	Mw
Pulse Forward Current (1/10 duty and 1mec width)	I_{FP}	80	mA
DC Forward Current	I_F	25	mA
Reverse Voltage	V_R	5	V
Operating Temperature Range	Topr	-20℃ ~ 85℃	℃
Storage Temperature Range	Tstg	-30℃ ~ 100℃	℃

◆ Electrical Optical Characteristics (Ta=25℃)

Parameter		Symbol	Min	Typ.	Max.	Unit	Test Condition
Luminous Intensity	Rank1	I_V	200	--	250	mcd	$I_F=15mA$
	Rank2		250	--	320		
	Rank3		320	--	400		
Forward Voltage	Rank1	VF	1.9	--	2.0	V	$I_F=15mA$
	Rank2		2.0	--	2.1		
	Rank3		2.1	--	2.2		
Reverse Current		IR	--	--	10	uA	$V_R=5V$
Dominant Wavelength	Rank1	λ_d	584	--	586	nm	$I_F=15mA$
	Rank2		586	--	588		
	Rank3		588	--	590		
Spectral Line Half Width		$\Delta \lambda$	--	30	--	nm	$I_F=15mA$
Viewing Angle		$2\theta_{1/2}$	--	120	--	Deg.	$I_F=15mA$

◆ Package Label: (For example)

CHIP LED		
TYPE:	WR-PB1608UY-M09	← LED Type
		← Part No.
VF:	x.x~x.x V	← Parameter Classing
λD:	xxx~xxx nm	
IV:	xxx~xxx mcd	
QUTY:	xxx PCS	← Quantity
DATE:	2007-06-05	← Sealing Date (year-month-day)
	CP. 00009	
	ST. 01142210	

◆ Soldering Pad Dimensions:

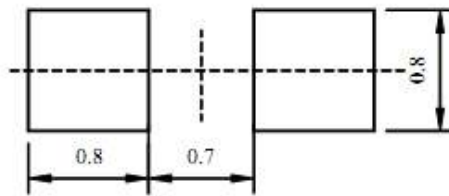

◆ Soldering Conditions (Maximum allowable soldering conditions)

1、Reflow soldering profile

<Pb-free solder>

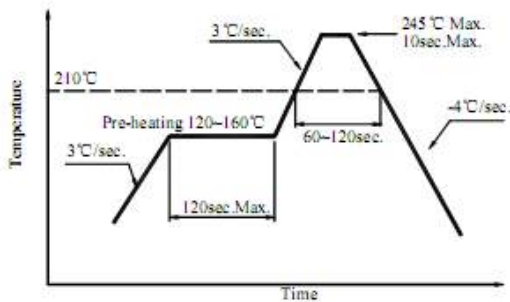

<Lead solder>

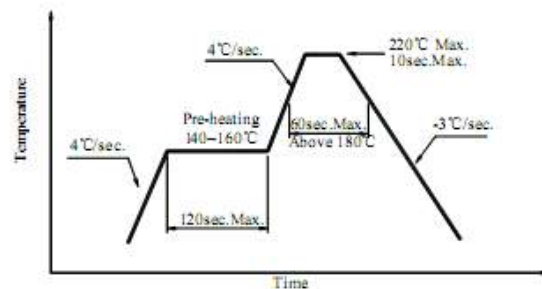

2、Soldering Iron

Power dissipation of Iron should be smaller than 15W, and temperature should be controllable. The work must be finished within 3sec under 300°C, only once.

- Do not stress its resin while soldering.
- After soldering, do not warp the circuit board.

◆ Package Tape Specifications: (2000~4000 pcs/Reel)

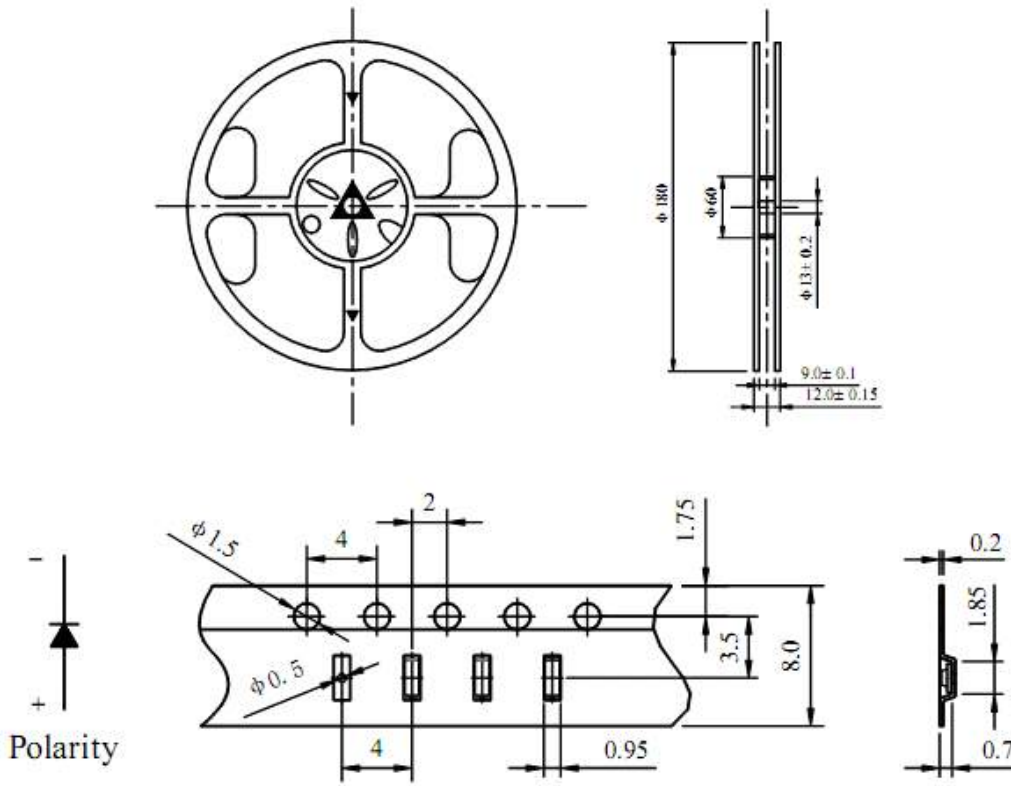

Reel Lead Min.60mm No LEDs

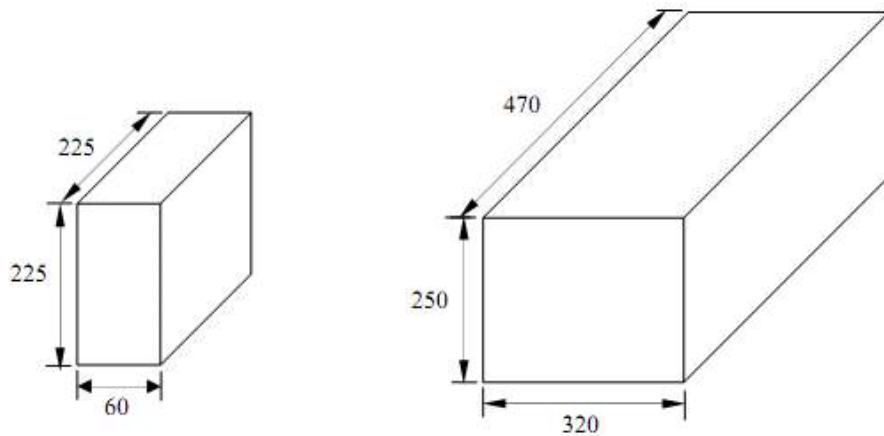

5 Reel in one Box

10 Box in one Carton

◆ Typical Electro-Optical Characteristics Curves:

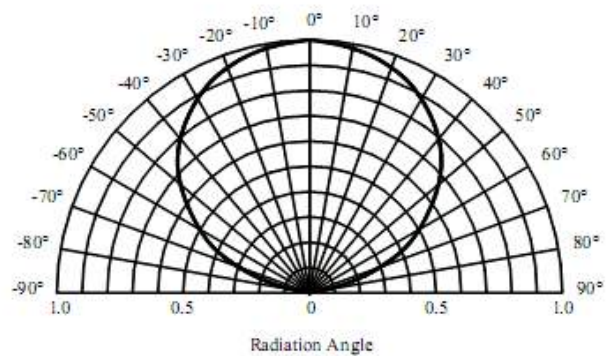
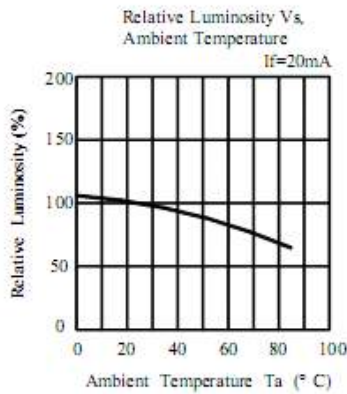
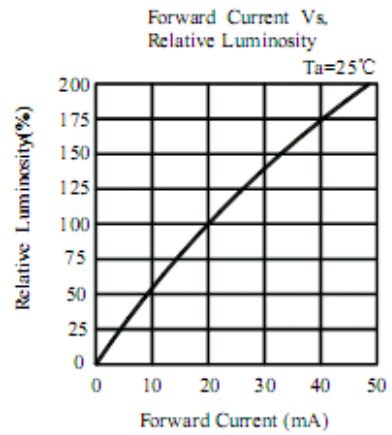
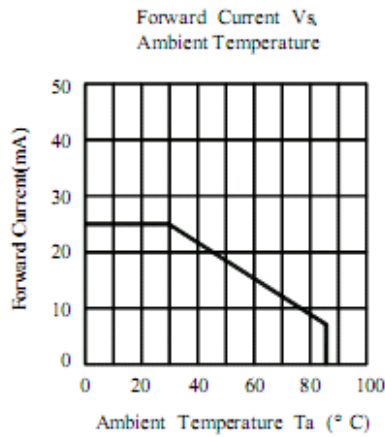
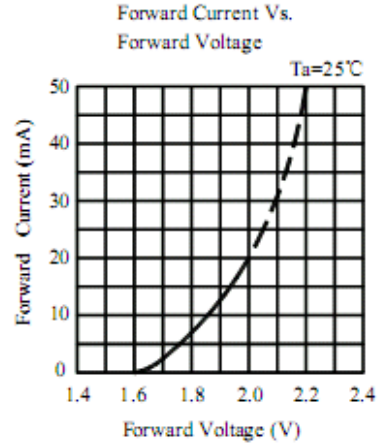
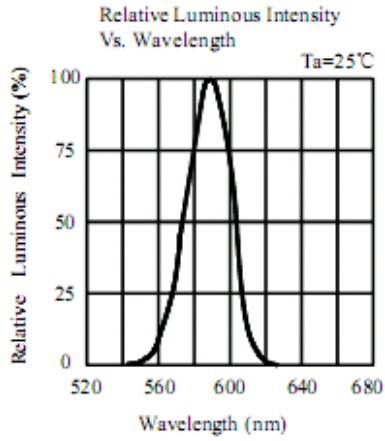

◆ Reliability Test Items and Conditions

NO	Test Item	Test Conditions	Duration	Sample	Ac/Re
1	Temperature Cycle	-40℃ ± 5℃ ~ 25℃ ± 5℃ 30min 5min / 100℃ ± 5℃ ~ 25℃ ± 5℃ 30min 5min	100cycles	20	0/1
2	High Temp. Storage	Ta=100℃ ± 5℃	1000hours	20	0/1
3	Temp.& Humidity Test	Tu=85℃ ± 5℃,RH=85% ± 5%	1000hours	20	0/1
4	Low Temp. Storage	Ta=-40℃ ± 5℃	1000hours	20	0/1
5	Operating Life Test	Ta=25 ± 5℃,DC IF=20mA	1000hours	20	0/1
6	Thermal Shock	+40 ± 5℃ → 100 ± 5℃ 15min 15min	100cycles	20	0/1

◆ Cautions

1. Package

When moisture is absorbed into the package it may vaporize and expand during soldering. There is a possibility that this can cause exfoliation of the contacts and damage to the optical characteristics of the LEDs. So the moisture proof package is used to keep moisture to a minimum in the package.

2. Storage

Before opening the package: The LEDs should be kept at 5~30°C and 60%RH or less. The LEDs should be used within a year.

After opening the package: The LED must be used within 24 hours, else should be kept at 5~30°C and 30% RH or less. The LEDs should be used within 7days after opening the package. If unused LEDs remain, they should be stored in moisture proof packages, recommended to return the LEDs to the original moisture proof bag and to reseal the moisture proof bag again.

If the LEDs have exceeded the storage time, baking treatment should be performed more than 24hours at 80 ± 5°C.

3、The LED electrode sections are comprised of a gold plated. The gold surface may be affected by environments which contain corrosive gases and so on. Please avoid conditions which may cause the LED to corrode or discolor. This corrosion or discoloration may cause difficulty during soldering operations. It is recommended that the User use the LEDs as soon as possible.

4、Please avoid rapid transitions in ambient temperature, especially in high humidity environments where condensation can occur.

◆ Notes:

1、Above specification may be changed without notice. We will reserve authority on material change for above specification.

2、When using this product, please observe the absolute maximum ratings and the instructions for the specification sheets. We assume no responsibility for any damage resulting from use of the product which does not comply with the instructions included in the specification sheets.