

4 | 3 | 2 | 1

E

D

C

B

A

E

D

C

B

A

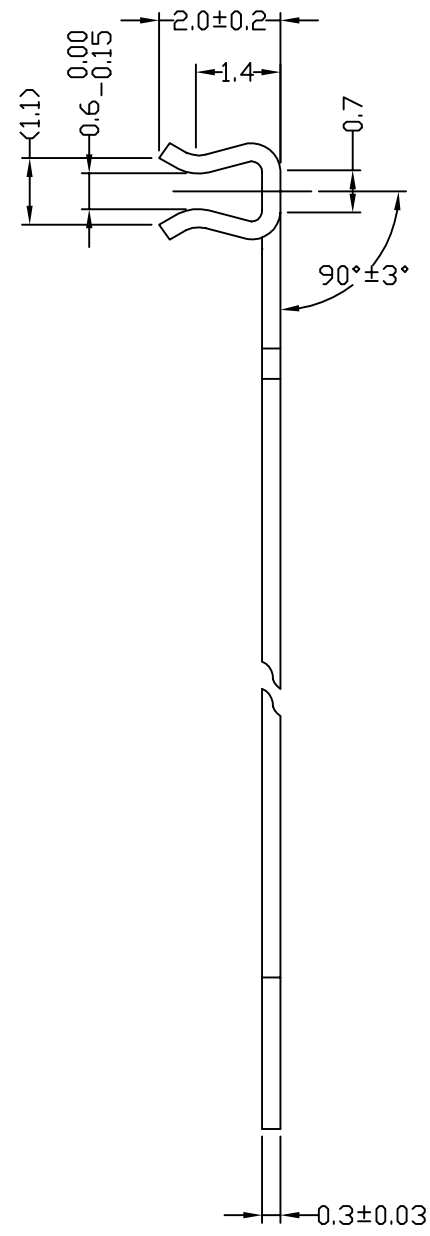
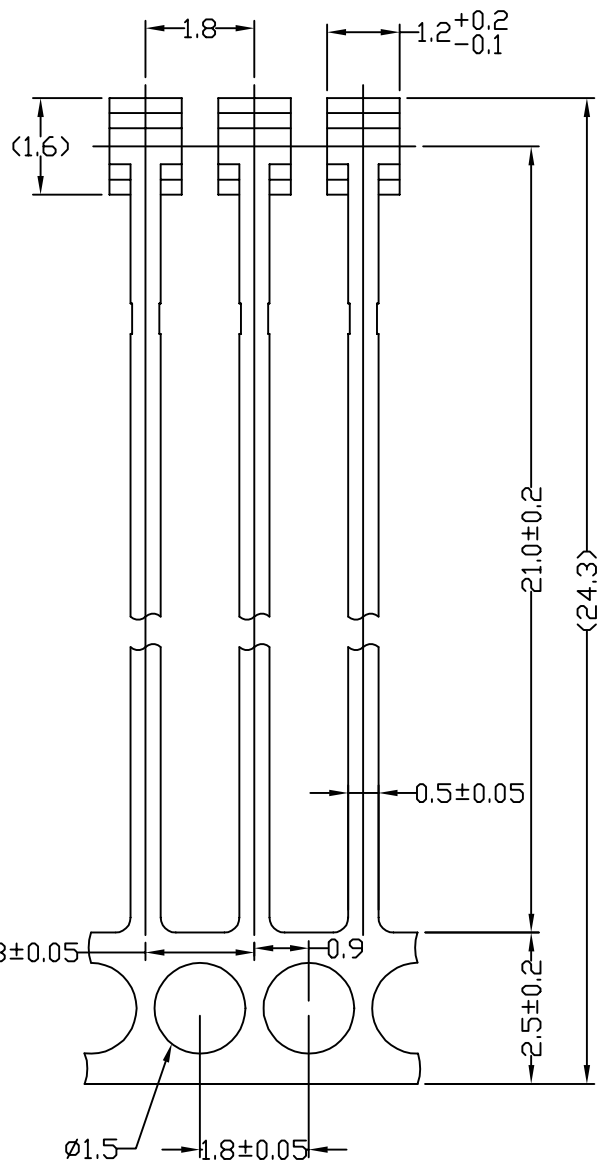

ALLOWANCE	F	G	H	J	K	L	M	N
UNDER 8	$\pm 0.05$	$\pm 0.1$	$\pm 0.1$	$\pm 0.2$	$\pm 0.2$	$\pm 0.4$	$\pm 0.4$	$\pm 1.0$
8 TO 25	0.08	0.15	0.15	0.3	0.3	0.6	0.6	1.5
25 TO 80	0.12	0.2	0.25	0.4	0.5	0.8	1.0	2.0
80 TO 250	0.25	0.3	0.4	0.6	0.8	1.2	1.5	3.0
250 TO 800	0.5	0.6	0.8	1.0	1.5	2.0	3.0	6.0
800 TO 2500	1.0	1.0	1.5	1.7	3.0	4.0	6.0	12.0
OVER 2500	2.0	2.0	3.0	3.0	6.0	8.0	12.0	24.0

REV	ZONE - CHANGES	ER*	DATE
			99/11/4

**NEXT ISSUED :**  
 UNLESS OTHERWISE STATED:  
 1/ WALL THICKNESS;  
 2/ ALL DIM. IN MM  
 3/ TOLERANCE:  
 .X.X+/-  
 XX.X+/-  
 XXX.X+/-  
 4/ TEXTURE;  
 5/ COATING;  
 6/ DRAFT ANGLE;  
 7/ UNSPECIFIED CORNER;

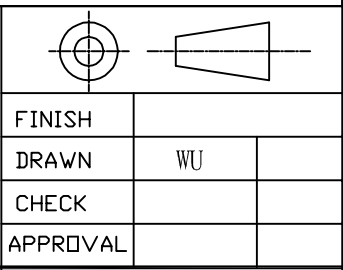

FINISH	TITLE Pin-821-0.7
DRAWN WU	MODEL
CHECK	SCALE: 8:1
APPROVAL	DWG NO. REV. A PAGE 1 OF 1
MAT'L & COLOR	

4 | 3 | 2 | 1