

4

3

2

1

E

D

C

B

A

E

D

C

B

A

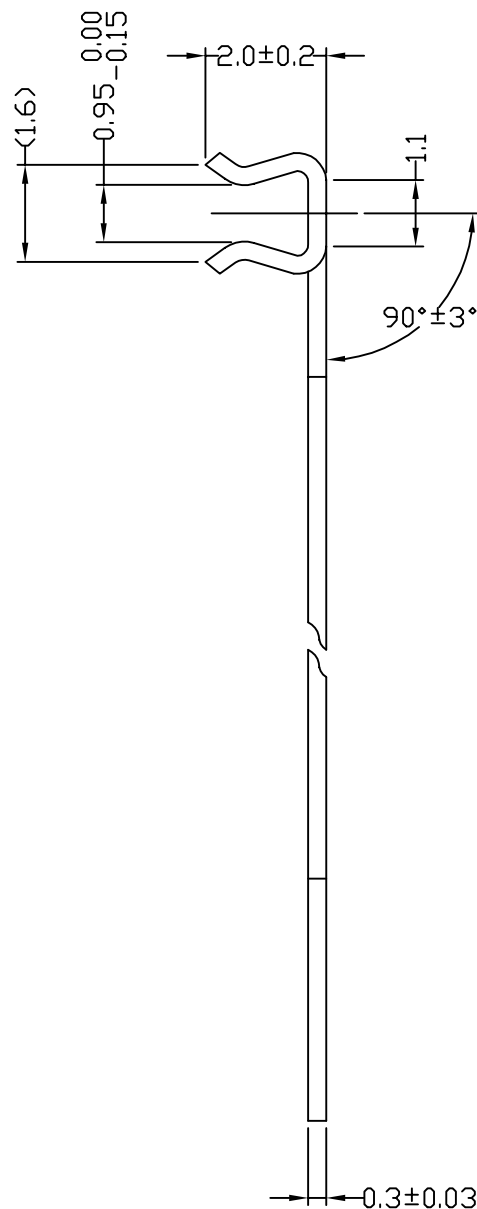
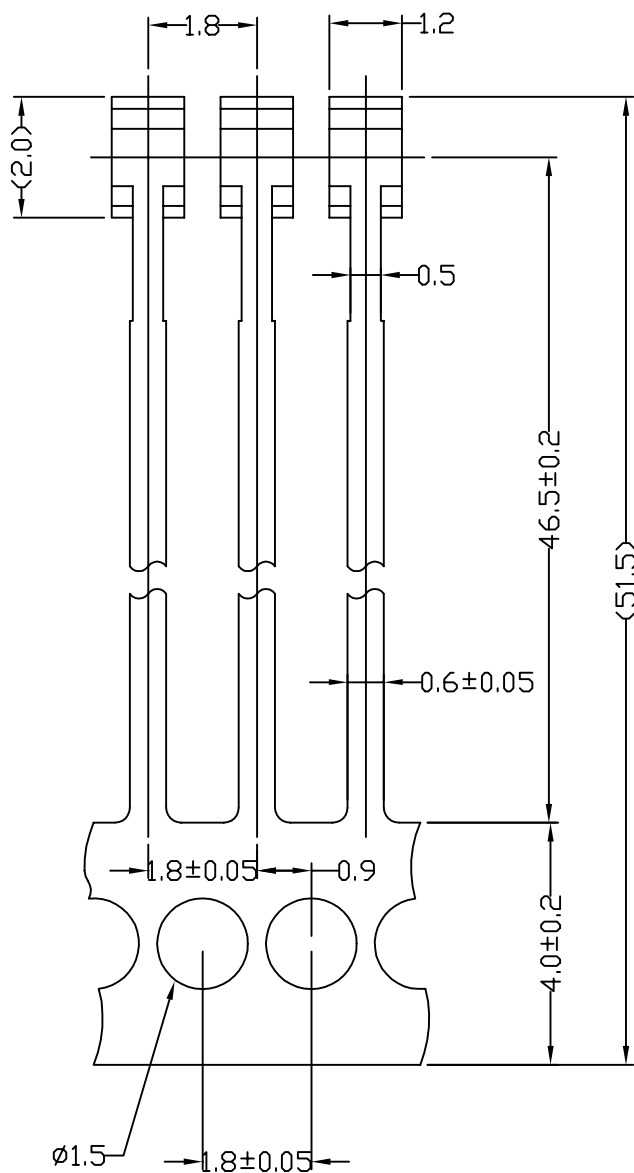

ALLOWANCE	F	G	H	J	K	L	M	N
UNDER 8	$\pm 0.05$	$\pm 0.1$	$\pm 0.1$	$\pm 0.2$	$\pm 0.2$	$\pm 0.4$	$\pm 0.4$	$\pm 1.0$
8 TO 25	0.08	0.15	0.15	0.3	0.3	0.6	0.6	1.5
25 TO 80	0.12	0.2	0.25	0.4	0.5	0.8	1.0	2.0
80 TO 250	0.25	0.3	0.4	0.6	0.8	1.2	1.5	3.0
250 TO 800	0.5	0.6	0.8	1.0	1.5	2.0	3.0	6.0
800 TO 2500	1.0	1.0	1.5	1.7	3.0	4.0	6.0	12.0
OVER 2500	2.0	2.0	3.0	3.0	6.0	8.0	12.0	24.0

REV	ZONE - CHANGES	ER*	DATE
			99/11/3

**UNLESS OTHERWISE STATED:**

- 1/ WALL THICKNESS;
- 2/ ALL DIM. IN MM
- 3/ TOLERANCE:  
XX.X+/-  
XX.X+/-  
XXX.X+/-
- 4/ TEXTURE;
- 5/ COATING;
- 6/ DRAFT ANGLE;
- 7/ UNSPECIFIED CORNER;

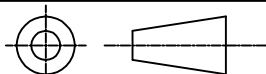

**ORIENT DISPLAY**

FINISH		TITLE	Pin-811-1.0
DRAWN	WU	MODEL	DWG NO.
CHECK		SCALE:	8:1
APPROVAL		MAT'L & COLOR	REV. A PAGE 1 OF 1

4

3

2

1