

4

3

2

1

E

E

D

D

C

C

B

B

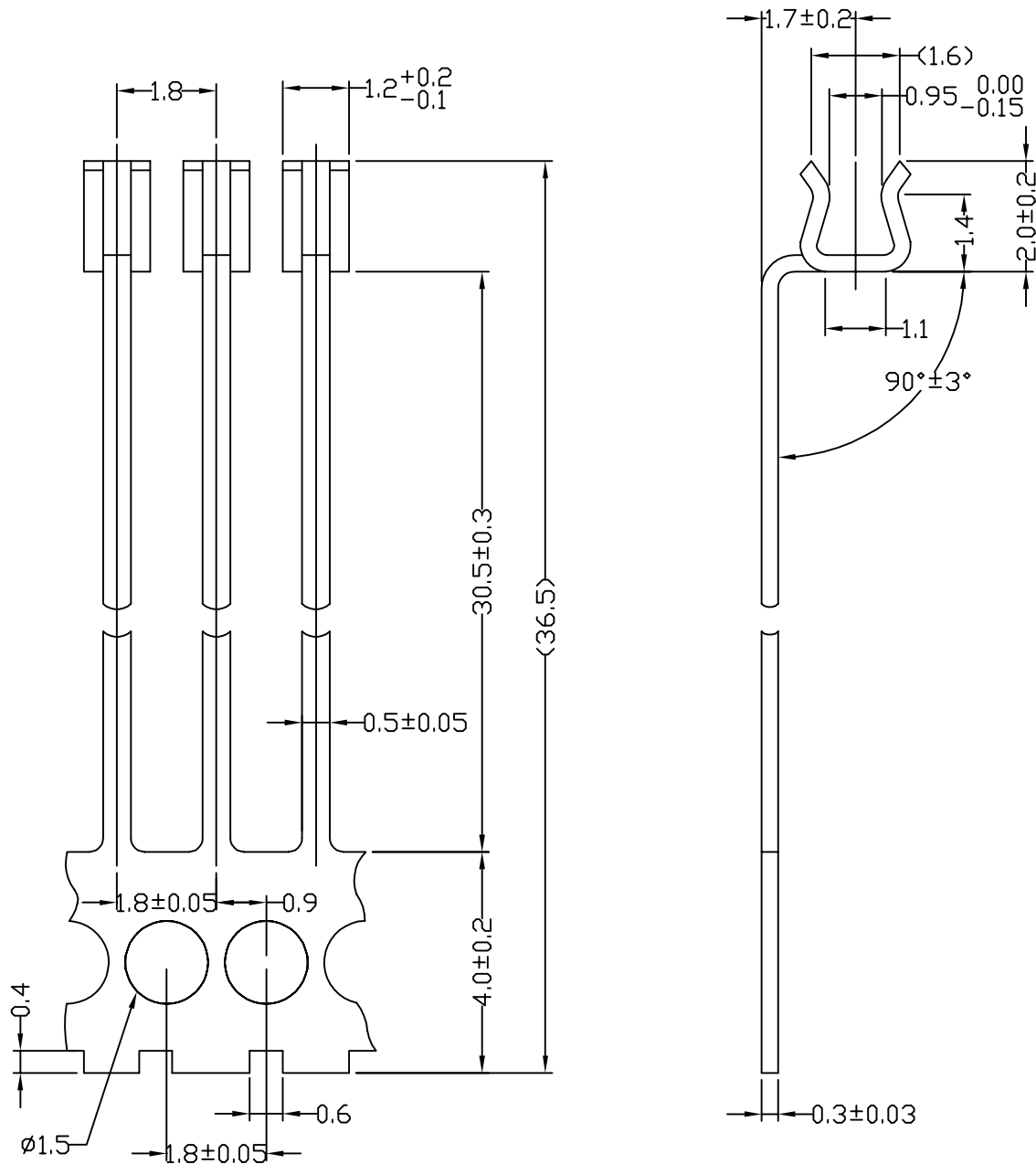

| ALLOWANCE | F | G | H | J | K | L | M | N |
|-------------|------------|-----------|-----------|-----------|-----------|-----------|-----------|-----------|
| UNDER 8 | ± 0.05 | ± 0.1 | ± 0.1 | ± 0.2 | ± 0.2 | ± 0.4 | ± 0.4 | ± 1.0 |
| 8 TO 25 | 0.08 | 0.15 | 0.15 | 0.3 | 0.3 | 0.6 | 0.6 | 1.5 |
| 25 TO 80 | 0.12 | 0.2 | 0.25 | 0.4 | 0.5 | 0.8 | 1.0 | 2.0 |
| 80 TO 250 | 0.25 | 0.3 | 0.4 | 0.6 | 0.8 | 1.2 | 1.5 | 3.0 |
| 250 TO 800 | 0.5 | 0.6 | 0.8 | 1.0 | 1.5 | 2.0 | 3.0 | 6.0 |
| 800 TO 2500 | 1.0 | 1.0 | 1.5 | 1.7 | 3.0 | 4.0 | 6.0 | 12.0 |
| OVER 2500 | 2.0 | 2.0 | 3.0 | 3.0 | 6.0 | 8.0 | 12.0 | 24.0 |

| | | | |
|-----|----------------|-----|---------|
| REV | ZONE - CHANGES | ER* | DATE |
| | | | 99/11/3 |

UNLESS OTHERWISE STATED:

- 1/ WALL THICKNESS;
- 2/ ALL DIM. IN MM
- 3/ TOLERANCE:
X.X+/-
XX.X+/-
XXX.X+/-
- 4/ TEXTURE;
- 5/ COATING;
- 6/ DRAFT ANGLE;
- 7/ UNSPECIFIED CORNER;

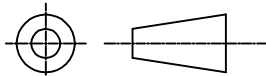

ORIENT DISPLAY

| | | | |
|----------|----|-------------------|--------------------|
| FINISH | | TITLE Pin-801-1.0 | |
| DRAWN | WU | MODEL | DWG NO. |
| CHECK | | SCALE: 8:1 | REV. A PAGE 1 OF 1 |
| APPROVAL | | MAT'L & COLOR | |

4

3

2

1

A

A