

4 | 3 | 2 | 1

E
D
C
B
A

E
D
C
B
A

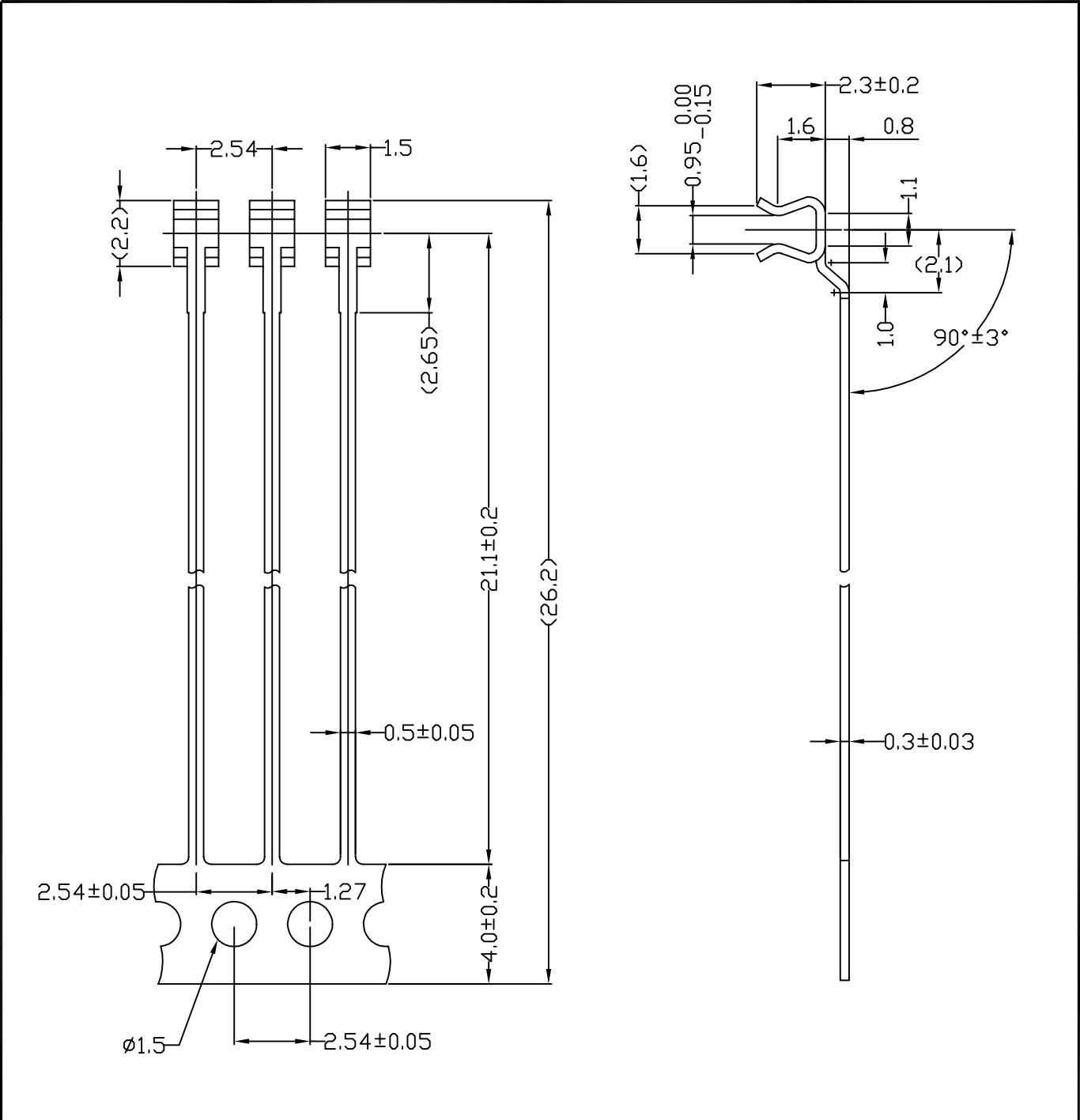

ALLOWANCE	F	G	H	J	K	L	M	N
UNDER 8	± 0.05	± 0.1	± 0.1	± 0.2	± 0.2	± 0.4	± 0.4	± 1.0
8 TO 25	0.08	0.15	0.15	0.3	0.3	0.6	0.6	1.5
25 TO 80	0.12	0.2	0.25	0.4	0.5	0.8	1.0	2.0
80 TO 250	0.25	0.3	0.4	0.6	0.8	1.2	1.5	3.0
250 TO 800	0.5	0.6	0.8	1.0	1.5	2.0	3.0	6.0
800 TO 2500	1.0	1.0	1.5	1.7	3.0	4.0	6.0	12.0
OVER 2500	2.0	2.0	3.0	3.0	6.0	8.0	12.0	24.0

REV	ZONE - CHANGES	ER*	DATE
-----	----------------	-----	------

NEXT ISSUED :
 UNLESS OTHERWISE STATED:
 1/ WALL THICKNESS:
 2/ ALL DIM. IN MM
 3/ TOLERANCE:
 X.X+/-
 XX.X+/-
 XXX.X+/-
 4/ TEXTURE:
 5/ COATING:
 6/ DRAFT ANGLE:
 7/ UNSPECIFIED CORNER:

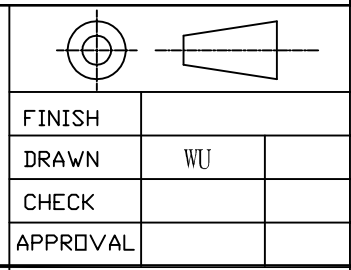

ORIENT DISPLAY

TITLE Pin-301-1.0

DRAWN WU	MODEL	DWG NO.
CHECK	SCALE: 5:1	REV. A PAGE 1 OF 1
APPROVAL	MAT'L & COLOR	

4 | 3 | 2 | 1

A

A