

4 | 3 | 2 | 1

E

E

D

D

C

C

B

B

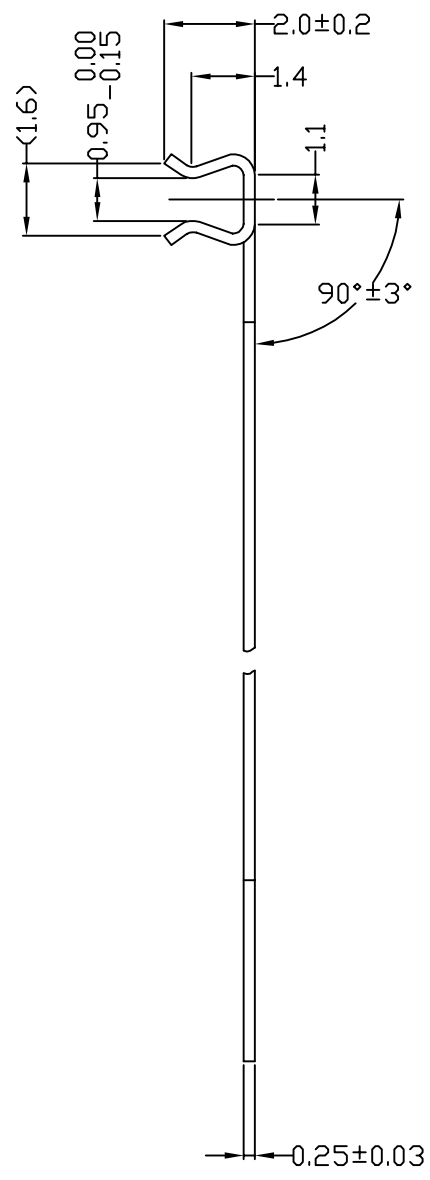
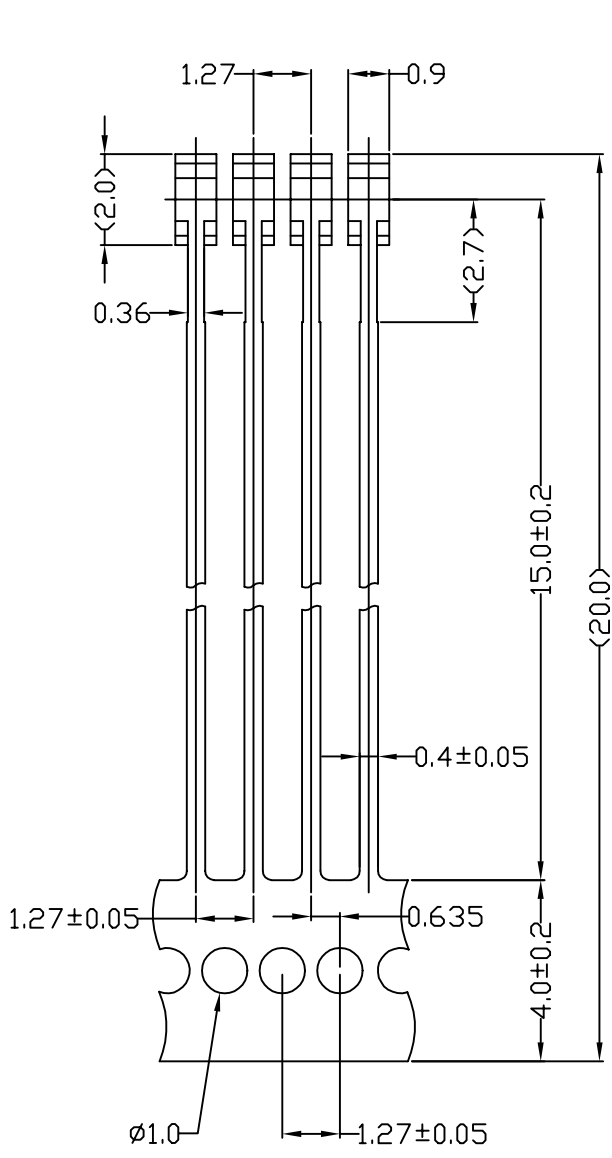

ALLOWANCE	F	G	H	J	K	L	M	N
UNDER 8	$\pm 0.05$	$\pm 0.1$	$\pm 0.1$	$\pm 0.2$	$\pm 0.2$	$\pm 0.4$	$\pm 0.4$	$\pm 1.0$
8 TO 25	0.08	0.15	0.15	0.3	0.3	0.6	0.6	1.5
25 TO 80	0.12	0.2	0.25	0.4	0.5	0.8	1.0	2.0
80 TO 250	0.25	0.3	0.4	0.6	0.8	1.2	1.5	3.0
250 TO 800	0.5	0.6	0.8	1.0	1.5	2.0	3.0	6.0
800 TO 2500	1.0	1.0	1.5	1.7	3.0	4.0	6.0	12.0
OVER 2500	2.0	2.0	3.0	3.0	6.0	8.0	12.0	24.0

REV	ZONE - CHANGES	ER*	DATE
			99/10/30

**NEXT ISSUED ..**  
 UNLESS OTHERWISE STATED:  
 1/ WALL THICKNESS;  
 2/ ALL DIM. IN MM  
 3/ TOLERANCE:  
 X.X+/-  
 XX.X+/-  
 XXX.X+/-  
 4/ TEXTURE;  
 5/ COATING;  
 6/ DRAFT ANGLE;  
 7/ UNSPECIFIED CORNER;

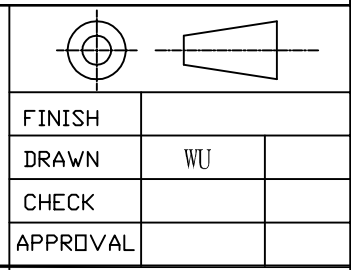

		TITLE Pin-171-1.0	
		MODEL	DWG NO.
DRAWN WU		SCALE: 6:1	REV. A PAGE 1 OF 1
CHECK		MAT'L & COLOR	
APPROVAL			

4 | 3 | 2 | 1

A

A