

4

3

2

1

E

E

D

D

C

C

B

B

A

A

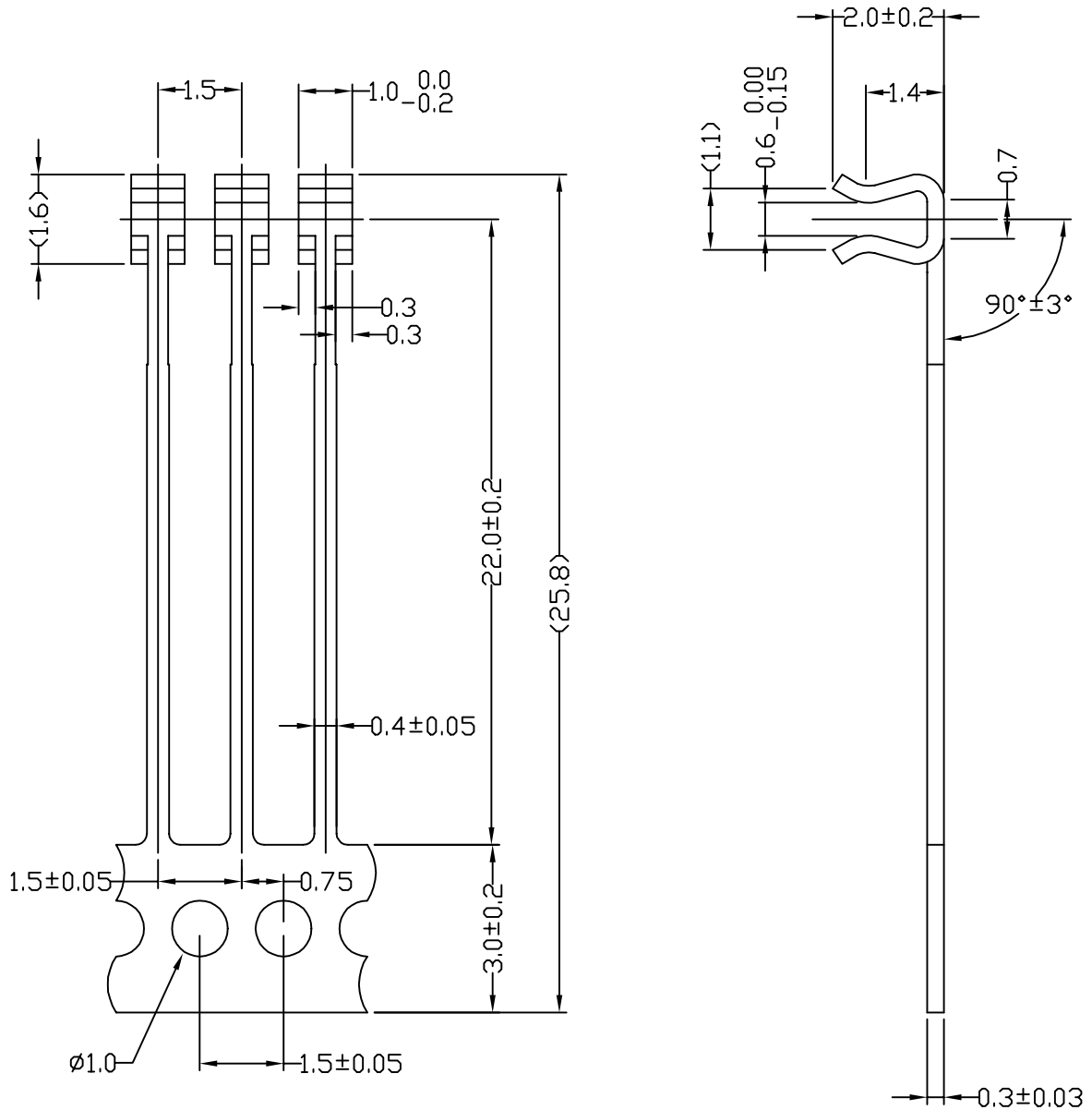

ALLOWANCE	F	G	H	J	K	L	M	N
UNDER 8	±0.05	±0.1	±0.1	±0.2	±0.2	±0.4	±0.4	±1.0
8 TO 25	0.08	0.15	0.15	0.3	0.3	0.6	0.6	1.5
25 TO 80	0.12	0.2	0.25	0.4	0.5	0.8	1.0	2.0
80 TO 250	0.25	0.3	0.4	0.6	0.8	1.2	1.5	3.0
250 TO 800	0.5	0.6	0.8	1.0	1.5	2.0	3.0	6.0
800 TO 2500	1.0	1.0	1.5	1.7	3.0	4.0	6.0	12.0
OVER 2500	2.0	2.0	3.0	3.0	6.0	8.0	12.0	24.0

REV

ZONE - CHANGES

ER*

99/10/29

DATE

NEXT ISSUED :

- UNLESS OTHERWISE STATED:
 1/ WALL THICKNESS:
 2/ ALL DIM. IN MM
 3/ TOLERANCE:
 X.X+/-
 XX.X+/-
 XXX.X+/-
 4/ TEXTURE:
 5/ COATING:
 6/ DRAFT ANGLE:
 7/ UNSPECIFIED CORNER:

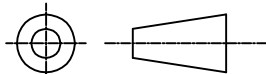

FINISH

TITLE Pin-151-0.7

DRAWN

WU

MODEL

DWG NO.

CHECK

SCALE: 8:1

REV. A PAGE 1 OF 1

APPROVAL

MAT'L & COLOR

4

3

2

1