

ShenZhen JuFei Optoelectronics Co., Ltd.



01.JT.CB320ZB-B

● Customer:

PN: JT.CB320ZB-B

For: IF= 30mA

Contents

1. Features
2. Applications
3. Package outline dimension
4. Absolute maximum ratings
5. Electrical-optical characteristics
6. Typical electro-optical characteristics curves
7. Tapping specifications
8. Package method
9. Label description
10. BIN range
11. Reliability test items and conditions
12. Precautions for use

Customer confirm	Approved	Checked	Issued

ShenZhen JuFei Optoelectronics Co., Ltd.

No. 4, Eling Industrial Area, Egongling Community, Pinghu Street, Longgang District, Shenzhen City

Tel: +86-755-29632290

Fax: +86-755-29632282

ShenZhen JuFei Optoelectronics Co., Ltd.



01.JT.CB320ZB-B

1、 Features:

- 1.1 Package: 3.0*2.0*1.2mm (Top view white LED)
- 1.2 Emitted Color: White
- 1.3 Soldering methods: All SMT assembly methods
- 1.4 Comply RoHS standard

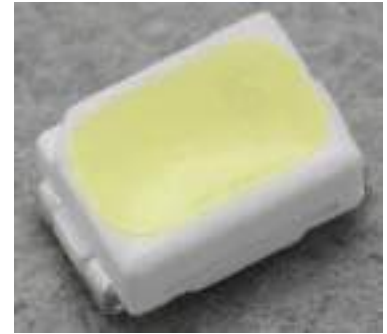

2、 Applications:

- 2.1 Back light for NB, Monitor, LED LCD TV.
- 2.2 Indoor Lighting.

3、 Package Outline Dimension:

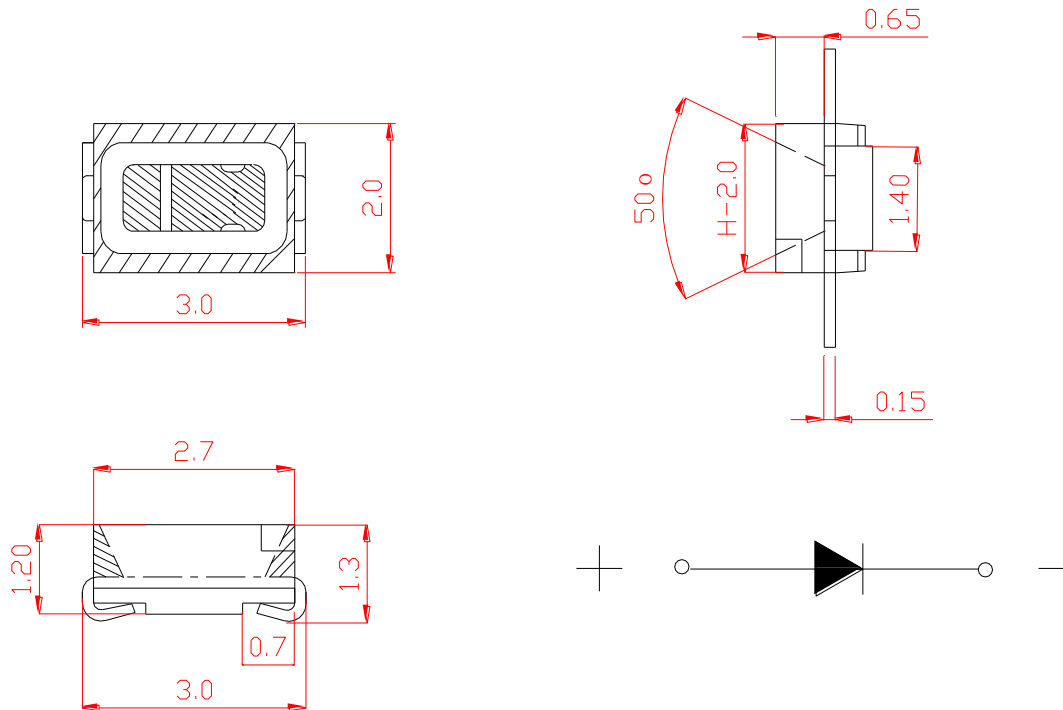

[Recommended soldering pad design]

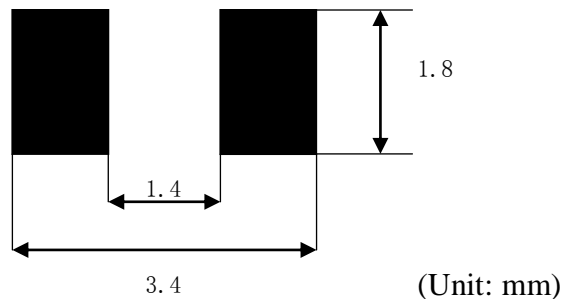

NOTES:

- 1. All dimensions are in millimeters (inches).
- 2. Tolerance is ± 0.10 mm unless otherwise specified.

ShenZhen JuFei Optoelectronics Co., Ltd.



01.JT.CB320ZB-B

4、 Absolute Maximum Ratings(Ta=25℃):

Parameter	Symbol	Rating	Unit
Power Dissipation	Pd	100	mW
Forward Current	I _F	35	mA
Peak Forward Current * 1	I _{FP}	60	mA
Reverse Voltage	V _R	5	V
Soldering Temperature	Tsol	Reflow soldering:260℃ for 10sec. Hand soldering:300℃ for 3 sec.	
Operating Temperature	Topr	-35℃~85℃	
Storage Temperature	Tstg	-40℃~100℃	

* I_{FP} condition: pulse width ≤0.1msec, duty cycle ≤1/10.

5、 Electrical-optical characteristics(Ta=25℃):

Parameter	Symbol	Min.	Typ.	Max.	Unit	Condition
Forward Voltage	V _f	3.0	-	3.4	V	I _F =30mA
Luminous Intensity	I _v	-	3200	-	mcd	
Viewing Angle	2θ _{1/2}	-	120	-	deg	
Color rendering index	CRI	70	-	-	-	
Reverse Current	I _R	-	0	0.5	uA	V _R =5V

Note: 1. Tolerance of luminous intensity is ±5%

2. Tolerance of forward voltage is ±0.03V

6、Typical Electro-Optical Characteristics Curves:

Relative intensity vs. wavelength(Ta=25 °C)

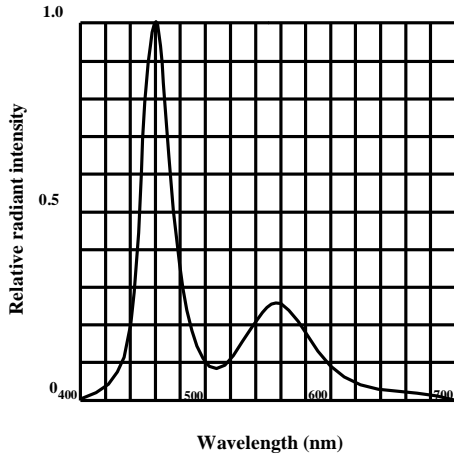

Forward current derating curve vs. ambient temperature

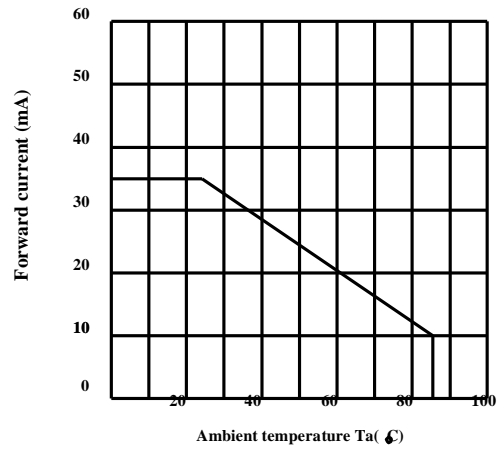

Forward current vs. forward voltage(Ta=25 °C)

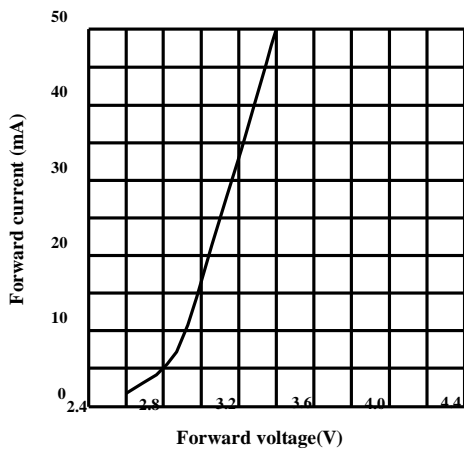

Luminous intensity vs. ambient temperature

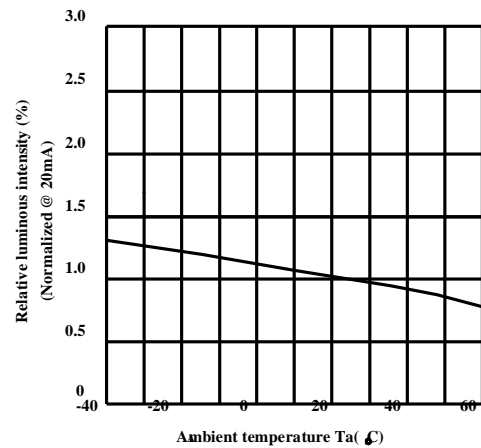

Relative luminous intensity vs. forward current

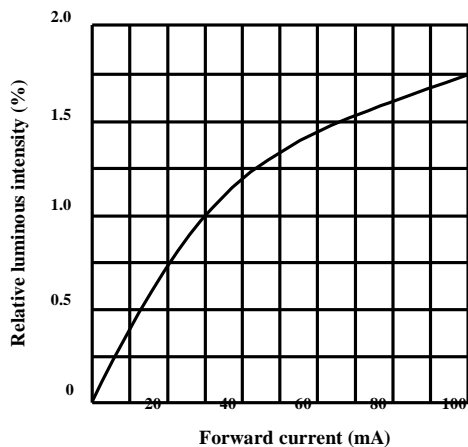

Radiation diagram

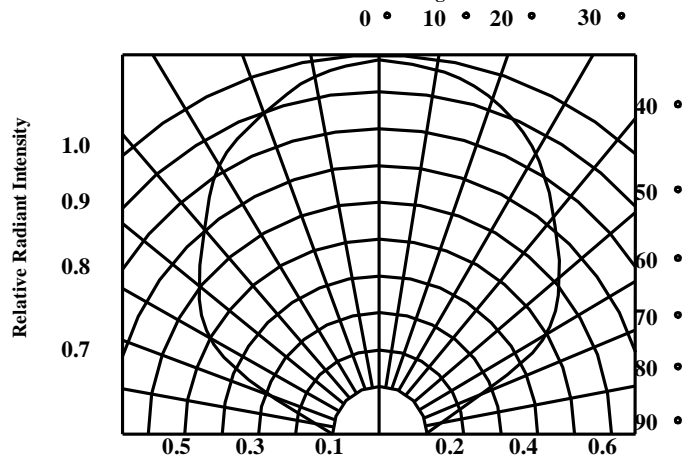

7、Tapping specifications (Units: mm):

Loaded quantity: 1000-2000 pcs/reel

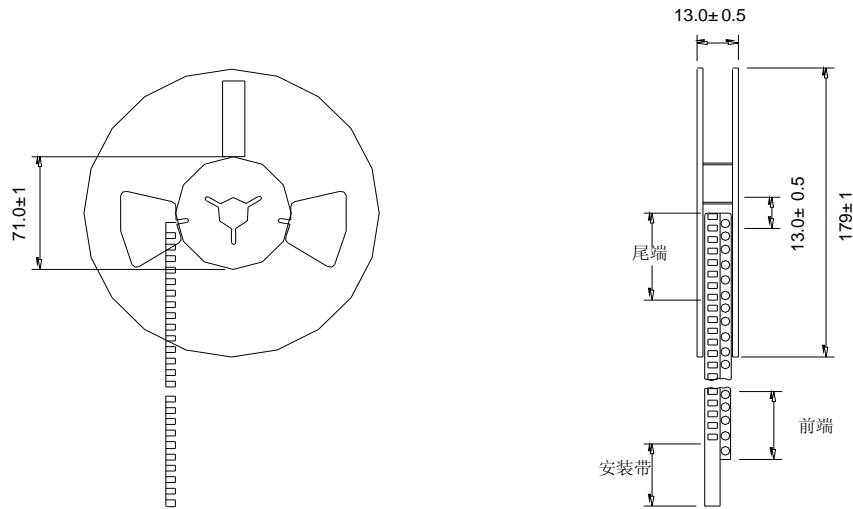
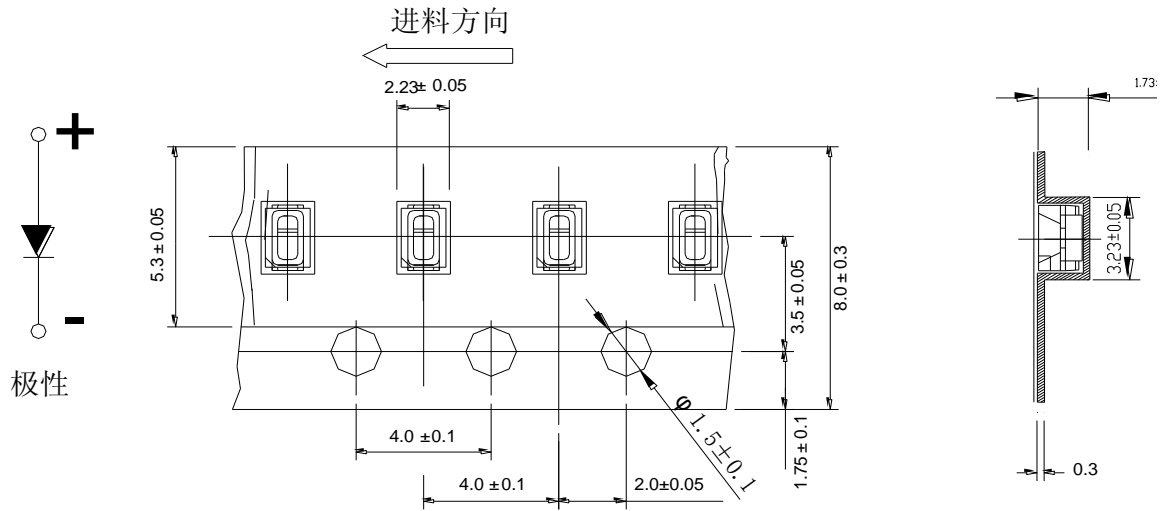

8、Package Method:(unit:mm)

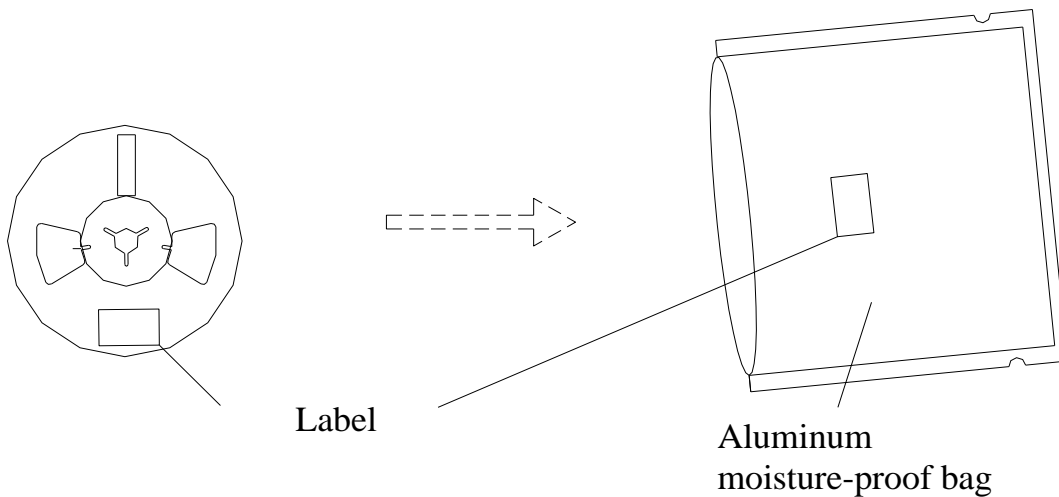

ShenZhen JuFei Optoelectronics Co., Ltd.



01.JT.CB320ZB-B

9、Label description :



BIN description: $x / x / x-x$

\uparrow Forward voltage BIN CODE
 \uparrow Chromaticity coordinates BIN CODE
 \uparrow Luminous intensity BIN CODE

Such as: BIN: 64/G/7-2

64 show luminous intensity BIN CODE

G show chromaticity coordinates BIN CODE

7-2 show forward voltage BIN CODE

10、BIN range

Luminous intensity (tolerance is $\pm 5\%$ @ $I_f=30\text{mA}$):

BIN CODE	Min. (mcd)	Max. (mcd)	Φ_v (Lm)
62	2700	2900	9.4-10.0
63	2900	3100	10.0-10.6
64	3100	3300	10.6-11.2
65	3300	3500	11.2-11.6
66	3500	3700	11.6-12.1
67	3700	3900	12.1-12.6

Forward voltage (tolerance is $\pm 0.03\text{V}$ @ $I_f=30\text{mA}$):

BIN CODE	Min. (V)	Max. (V)
6-1	2.9	3.0
6-2	3.0	3.1
7-1	3.1	3.2
7-2	3.2	3.3
8-1	3.3	3.4
8-2	3.4	3.5

ShenZhen JuFei Optoelectronics Co., Ltd.



01.JT.CB320ZB-B

Chromaticity coordinates specifications (tolerance is ± 0.005 @ $I_f=30\text{mA}$):

BIN	CIE-X	CIE-Y	BIN	CIE-X	CIE-Y
Q	0.2436	0.2138	A	0.2507	0.2270
	0.2507	0.2270		0.2578	0.2402
	0.2583	0.2232		0.2654	0.2364
	0.2512	0.2100		0.2583	0.2232
C	0.2578	0.2402	E	0.2649	0.2534
	0.2649	0.2534		0.2720	0.2666
	0.2725	0.2496		0.2796	0.2628
	0.2654	0.2364		0.2725	0.2496
G	0.2720	0.2666	I	0.2791	0.2798
	0.2791	0.2798		0.2862	0.2930
	0.2867	0.2760		0.2938	0.2892
	0.2796	0.2628		0.2867	0.2760
K	0.2862	0.2930			
	0.2933	0.3062			
	0.3009	0.3024			
	0.2938	0.2892			

CIE 1931:

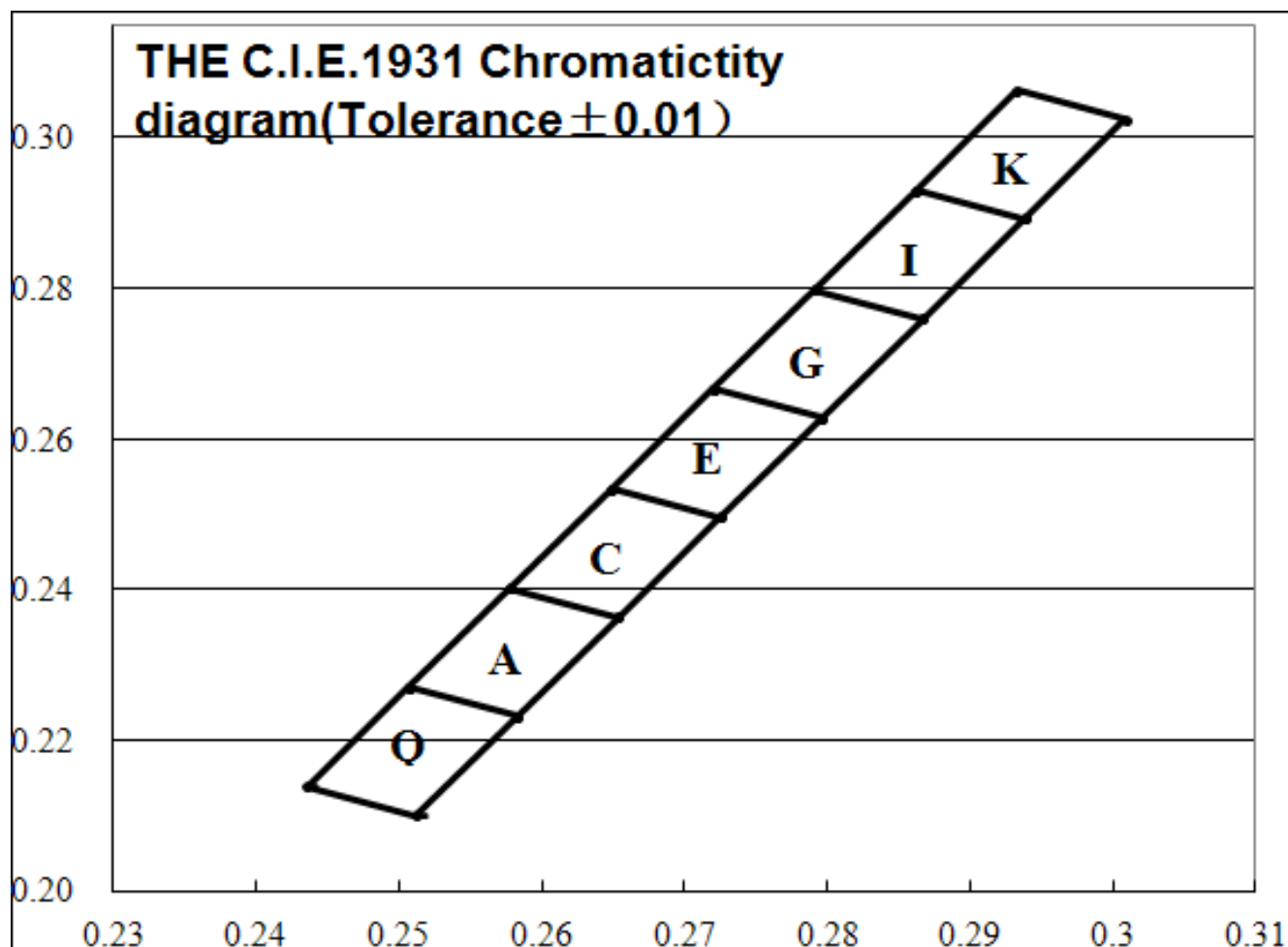

ShenZhen JuFei Optoelectronics Co., Ltd.



01.JT.CB320ZB-B

11、 Reliability test items and conditions:

No.	Test Item	Test Conditions	Sample size	Ac/Re
1	Operation Life	Test If=DC30mA Temp: Room temperature Test time=1000hrs	20	0/1
2	High Temperature High Humidity	Temp. =+65℃ RH=90% Test time=240hrs	20	0/1
3	Thermal Shock	-40℃ ~+100℃ 20min 10s 20min Test Time=100 cycles	20	0/1
4	High Temperature Storage	High Temp. =+100℃ Test time=1000hrs	20	0/1
5	Low Temperature Storage	Low Ta=-40℃ Test time=1000hrs	20	0/1
6	Temperature Cycle	-40℃ ~+100℃ 60min 20min 60min Test Time=20cycle	20	0/1
7	Reflow Soldering	Operation heating: 260℃(Max.), within 10seconds.(Max.)	20	0/1

※Judgment criteria of failure for the reliability

- Iv: Below 85% of initial values
- Vf: Over 10% of upper limit value

Note:

1. Measurement shall be taken within 2 hours
2. The tested LED have been returned to normal ambient conditions before testing.

12.Precautions for use

12.1 Soldering

SMD LED encapsulation is very flexible, outside force easily demolish radiant surface and plastic, As soldering , Please handle with care!

- With No-clean Flux, according to reflow soldering cure condition when soldering, Reflow soldering should not be done more than two times, simultaneity you must insure clean on the radiant surface. Otherwise, foreign objects can affect radiant color.
- Don't process manual soldering except repair. Recommended to be soldered with 25W Anti-static iron, The temp. of the iron should be lower than 300 °C and soldering time should not be done more than three seconds, at the same time iron can't touch radiant surface and plastic.
- Don't twist LED in course of manual soldering and experiment, Otherwise, the lights will not work possibly.
- Please use the same BIN grade in one panel, and don't mix the difference BIN grade in one panel when soldering. Otherwise, it will cause a serious uneven color problem.
- Please control the sulfur content of solder paste and PCB.
- Pb-free solder temp.-time profile as below:245 °C Max.

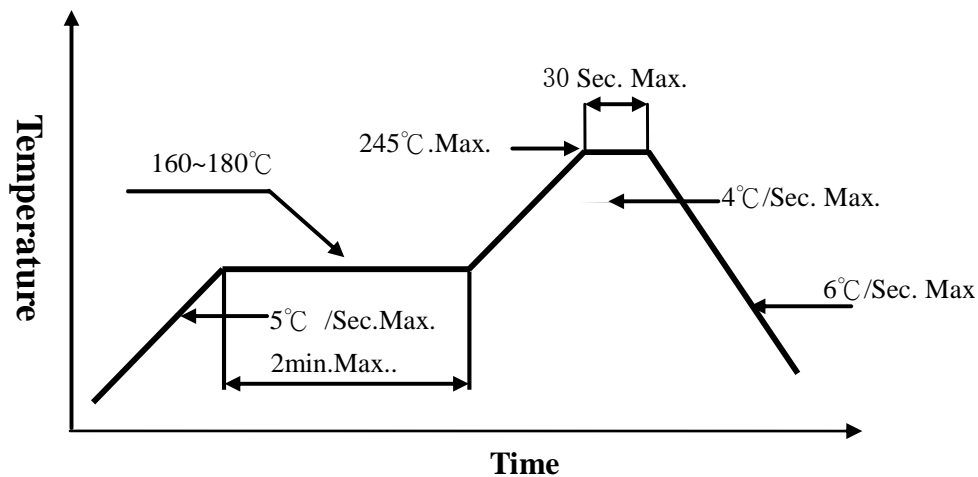

12.2 Cleaning

- Don't be cleaned with ultrasonic. Recommended to be wiped with isopropyl alcohol or pure alcohol, wiping time should not be more than one minute. LED must be placed at room temperature for fifteen minutes before using. after cleaning, you must insure clean on the radiant surface. Otherwise, foreign objects can affect radiant color.
- LED can not be in contact with isoamyl acetate、trichloroethylene、acetone、sulfid、nitride、acid、alkali、salt. These matter can destroy LED.

12.3 Sealing

- Sealing glue can not contain sodium ion、sulfid, because these matter can affect fluorescence powder poisoning.

- b. When using normal sealing glue, Recommended to be operated life for 168hrs under normal temperature.

12.4 Storage

- a. Don't open the moisture proof bag before ready to use the LEDs.
- b. The LEDs should be kept at 30°C or less and 60%RH or less before opening the package. The max. storage period before opening the package is 1 year.
- c. After opening the package, the LEDs should be kept at 30-35%RH or less, and it should be used within 3 days. If the LEDs should be kept at 30-35%RH or more, and it should be used within 4 hours.
- d. If the LEDs be kept over the conditions of 20%, baking is required before mounting. Baking condition as below: 70±5 °C for 12 hrs for bulk goods, 105±5 °C for 1 hrs for roll goods.
- e. The environment have no acid、alkali、corrosive gas、intensively shake and high magnetic field.

12.5 Static

- a. Static and Peak surge voltage can destroy LED, Avoiding Instantaneous voltage when turn on or turn off the lights.
- b. Please wear Anti-static wrist band、Anti-static glove、Anti-static shoes in the course of operation, and the equipment must be grounded.
- c. After LED is be destroyed, leakage current increase obviously, and it will be forward voltage falling or failure lamp in the case of low current.

12.6 Test

- a. Customer must apply the current limiting resistor in the circuit so as to drive the LEDs within the rated current. Otherwise slight voltage shift maybe will cause big current change and burn out will happen.
- b. Also, caution should be taken not to overload the LEDs with instantaneous high voltage at the turning ON and OFF of the circuit. Otherwise LED will be destroyed, testing methods as follows:

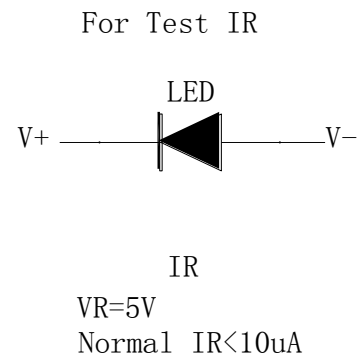
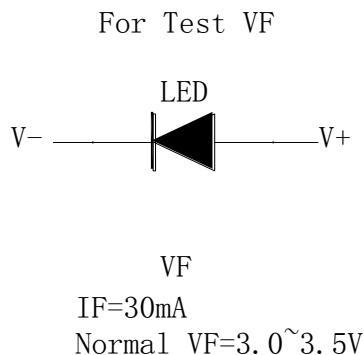

- c. The reverse voltage mustn't exceed 5v when lighting on or testing the LED, otherwise, the LEDs will be damaged.

12.7 Else

Radiant color of LEDs have a little change with the current, recommended that LED is be used in series and resistance, when lighting, please don't see directly radiant surface of LED, otherwise LED will burn eyes.