

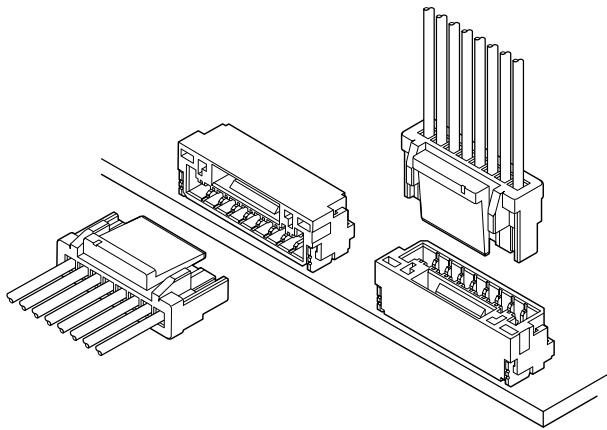

# GH CONNECTOR



1.25mm pitch/Disconnectable Crimp style connectors



**Developed for PDP, LCD or small electronics equipment.**  
**This low insertion force type connector realizes easier mating operation. The basic concept of the contact part of this connector is equivalent to the performance proven SHL connector.**

- Secure locking structure
- Contact lock structure
- Prevent deformation of contacts

## Specifications

- Current rating: 1.0A AC, DC (AWG #26)
  - Voltage rating: 50V AC, DC
  - Temperature range: -25°C to +85°C  
 (including temperature rise in applying electrical current)
  - Contact resistance: Initial value/30m Ω max.  
 After environmental testing/50m Ω max.
  - Insulation resistance: 100M Ω min.
  - Withstanding voltage: 500V AC/minute
  - Applicable wire: Conductor size/AWG #30 to #26  
 Insulation O.D./0.8 to 1.0mm
- \* RoHS compliant products are published.  
 \* Refer to "General Instruction and Notice when using Terminals and Connectors" at the end of this catalog.  
 \* Contact JST for details.

## Standards

Recognized E60389

## PC board layout (viewed from component side) and Assembly layout

### Top entry type

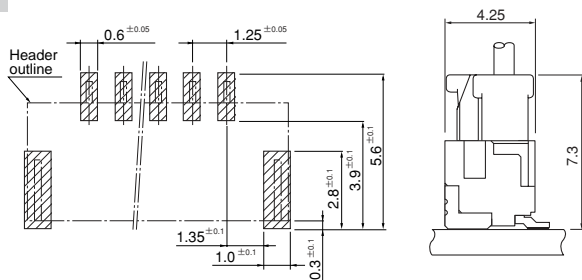

### Side entry type

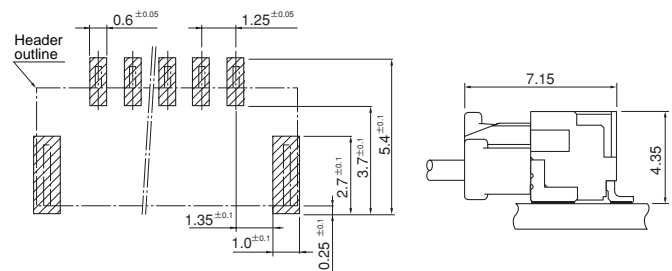

Note: 1. Tolerances are non-cumulative: ±0.05mm for all centers.  
 2. The dimensions above should serve as a guideline. Contact JST for details.

## Contact

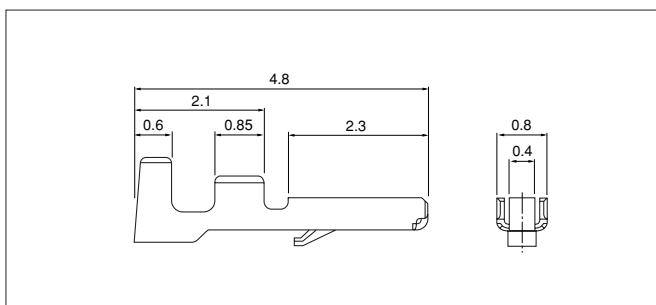

Model No.	Applicable wire		Insulation O.D. (mm)	Q'ty / reel
	mm <sup>2</sup>	AWG#		
SSHL-002T-P0.2	0.05~0.13	30~26	0.8~1.0	23,000

### Material and Finish

Phosphor bronze, tin-plated (reflow treatment)

### RoHS compliance

Note: 1. Contact JST for gold-plates products.  
 2. This contact can be applied only for GH connector.  
 SSLH-003( )-P0.2 cannot be applied for GH connector.

Contact	Crimping machine	Applicator		
		Crimp applicator	Dies	Crimp applicator with dies
SSHL-002T-P0.2	AP-K2N	MKS-L-10-3	MK/SSHL-002-02	APLMK SSLH002-02
		-	-	-

# GH CONNECTOR

## Housing

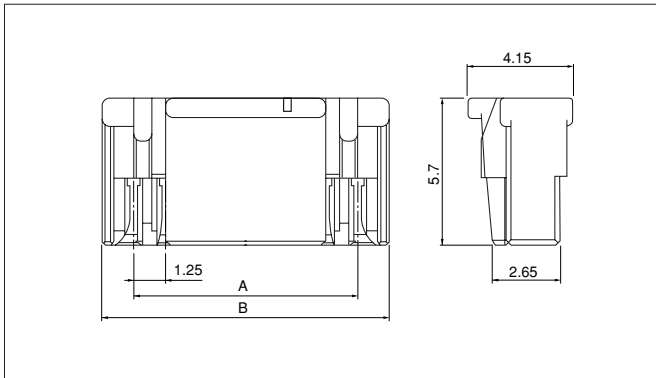

Circuits	Model No	Dimensions (mm)		Q'ty / box
		A	B	
2	<b>GHR-02V-S</b>	1.25	3.75	4,000
3	<b>GHR-03V-S</b>	2.50	5.00	3,000
4	<b>GHR-04V-S</b>	3.75	6.25	2,500
5	<b>GHR-05V-S</b>	5.00	7.50	2,000
6	<b>GHR-06V-S</b>	6.25	8.75	1,500
7	<b>GHR-07V-S</b>	7.50	10.00	1,500
8	<b>GHR-08V-S</b>	8.75	11.25	1,000
9	<b>GHR-09V-S</b>	10.00	12.50	1,000
10	<b>GHR-10V-S</b>	11.25	13.75	1,000
11	<b>GHR-11V-S</b>	12.50	15.00	1,000
12	<b>GHR-12V-S</b>	13.75	16.25	1,000
13	<b>GHR-13V-S</b>	15.00	17.50	1,000
14	<b>GHR-14V-S</b>	16.25	18.75	500
15	<b>GHR-15V-S</b>	17.50	20.00	500

### Material

PBT, UL94V-0, natural (white)

### RoHS compliance

## Shrouded header

### Top entry type

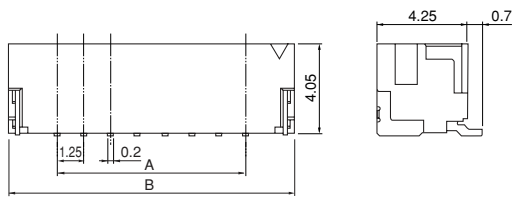

### Side entry type

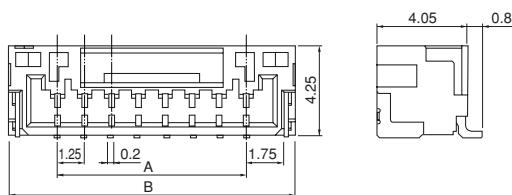

Circuits	Model No.		Dimensions (mm)		Q'ty / reel
	Top entry type	Side entry type	A	B	
2	<b>BM02B-GHS-TBT</b>	<b>SM02B-GHS-TB</b>	1.25	5.75	2,500
3	<b>BM03B-GHS-TBT</b>	<b>SM03B-GHS-TB</b>	2.50	7.00	2,500
4	<b>BM04B-GHS-TBT</b>	<b>SM04B-GHS-TB</b>	3.75	8.25	2,500
5	<b>BM05B-GHS-TBT</b>	<b>SM05B-GHS-TB</b>	5.00	9.50	2,500
6	<b>BM06B-GHS-TBT</b>	<b>SM06B-GHS-TB</b>	6.25	10.75	2,500
7	<b>BM07B-GHS-TBT</b>	<b>SM07B-GHS-TB</b>	7.50	12.00	2,500
8	<b>BM08B-GHS-TBT</b>	<b>SM08B-GHS-TB</b>	8.75	13.25	2,500
9	<b>BM09B-GHS-TBT</b>	<b>SM09B-GHS-TB</b>	10.00	14.50	2,500
10	<b>BM10B-GHS-TBT</b>	<b>SM10B-GHS-TB</b>	11.25	15.75	2,500
11	<b>BM11B-GHS-TBT</b>	<b>SM11B-GHS-TB</b>	12.50	17.00	2,500
12	<b>BM12B-GHS-TBT</b>	<b>SM12B-GHS-TB</b>	13.75	18.25	2,500
13	<b>BM13B-GHS-TBT</b>	<b>SM13B-GHS-TB</b>	15.00	19.50	2,500
14	<b>BM14B-GHS-TBT</b>	<b>SM14B-GHS-TB</b>	16.25	20.75	2,500
15	<b>BM15B-GHS-TBT</b>	<b>SM15B-GHS-TB</b>	17.50	22.00	2,500

### Material and Finish

Contact: Phosphor bronze, copper-undercoated, tin-plated (reflow treatment)  
Housing: PA9T, UL94V-0, natural (ivory)  
Solder tab: Brass, copper-undercoated, tin-plated

**RoHS compliance** This product displays (LF)(SN) on a label.  
Note: Contact JST for gold-plated products.

## Taping specifications

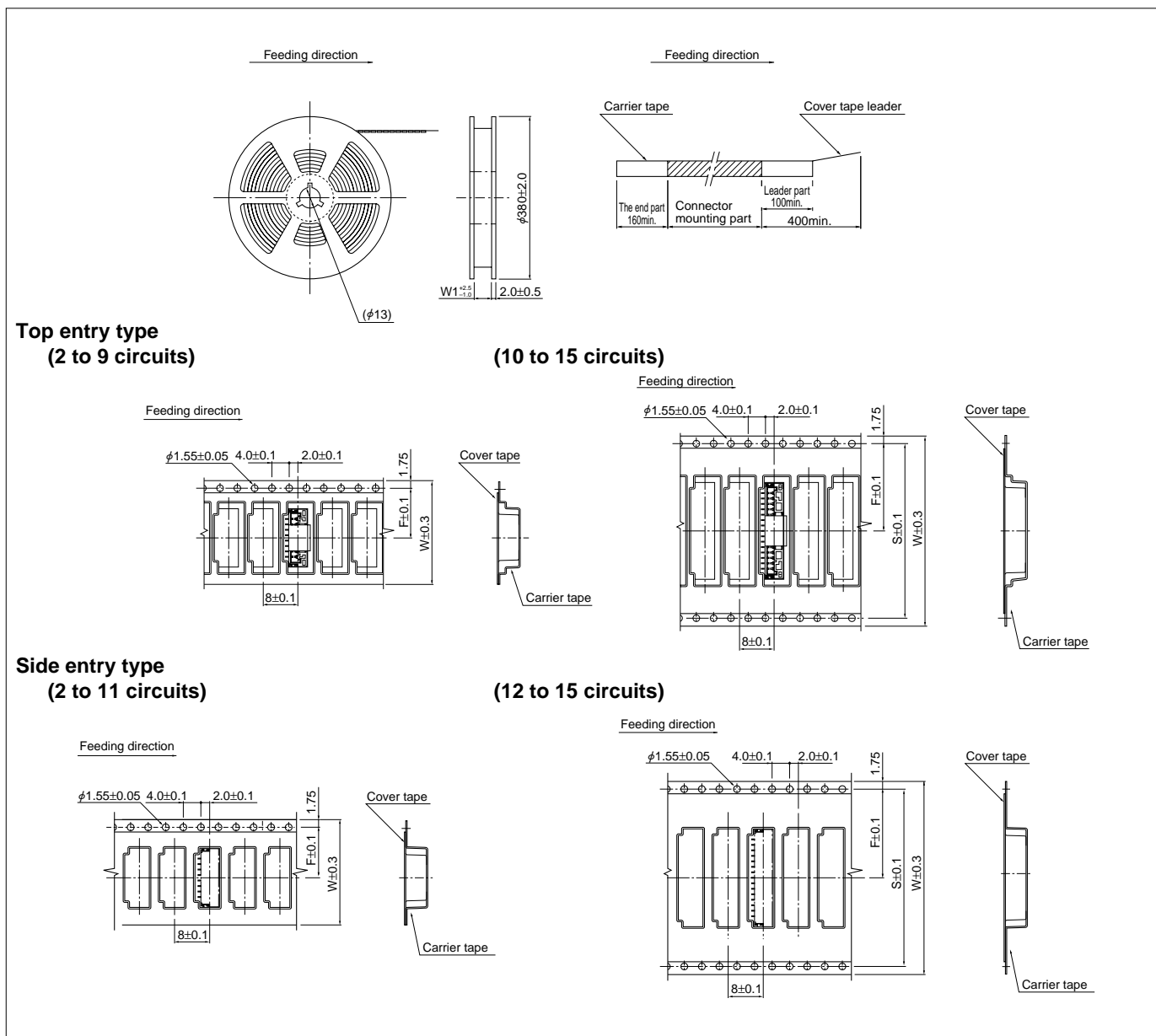

### Top entry type

Circuits	Dimensions (mm)			Reel dimensions (mm) W1	Q'ty / reel
	F	S	W		
2	7.5	—	16.0	17.5	2,500
3 to 9	11.5	—	24.0	25.5	2,500
10 to 12	14.2	28.4	32.0	33.5	2,500
13 to 15	20.2	40.4	44.0	45.5	2,500

### Side entry type

Circuits	Dimensions (mm)			Reel dimensions (mm) W1	Q'ty / reel
	F	S	W		
2 to 5	7.5	—	16.0	17.5	2,500
6 to 11	11.5	—	24.0	25.5	2,500
12 to 15	14.2	28.4	32.0	33.5	2,500

#### Note:

- Specifications conform to JIS C 0806. The tape width, connector loading recess square hole dimensions, etc. are determined by the number of circuits and external shape of the connector to be loaded.
- Specifications are subject to change without prior notice.