

0.5mm and 1mm Pitch Connectors For FPC/FFC

FH12 Series

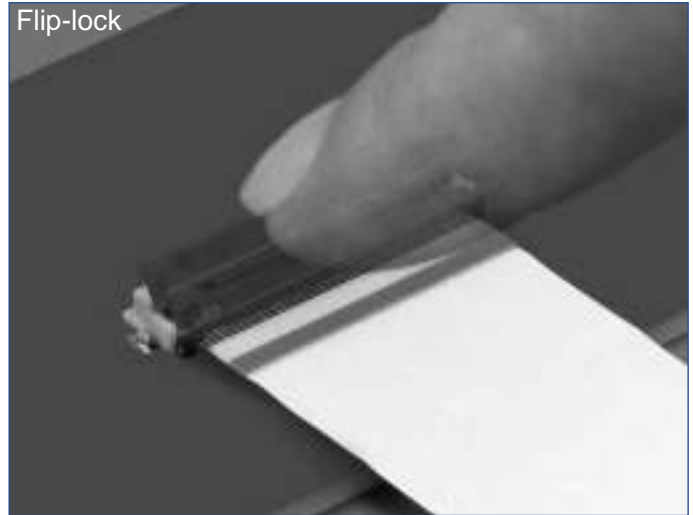
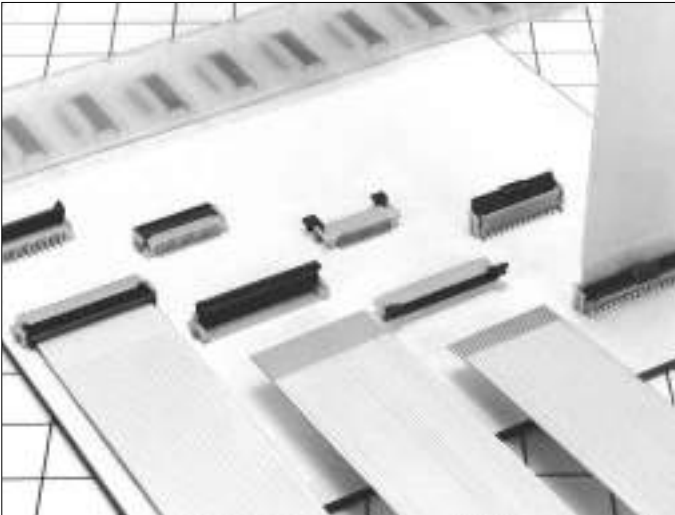

■ Features

1. Ease of Use and Space Savings

Only one finger or 6.9N (Newtons) of force is required to lock Hirose's rotational actuator (flip-lock) as compared to using 2 fingers and 39.2N to close a FFC/FPC connector from our competition.

The Flip-Lock design also allows customers to place 2 or more connectors side by side as there is no need to waste additional board space for a side latch.

2. Strengthened Flip-lock Actuator

The standard Flip-Lock requires only 2.0mm height above the board. A strengthened lock lever is available which only requires an additional 0.4mm.

3. Supports Thin FPC (0.18mm)

Hirose does not require double-sided FPC to have any additional strengthening plate or stiffener and can therefore support a thickness of as little as 0.18mm +/- 0.05.

4. Hirose Ensures Reliability

Hirose's patented half tuning fork contacts maintain the required normal force without relying on the connector housing. With our competitor's conventional products the housing walls support the contact force, which does not provide for long-term reliability.

5. Prevention of Solder Bridge

Excess solder cavity absorbs excessive solder and avoids solder bridging.

6. Three different assembly types

FH12 is offered in Top & Bottom Contact and Vertical Mount and offered in both a 0.5mm contact pitch as well as a 1.0mm contact pitch (bottom contact only).

■ Applications

Notebook computers, printers, PDAs, digital cameras and other compact devices for interconnecting the main circuit board with the LCD, HDD or other device.

Rotating One-touch Mechanism

①

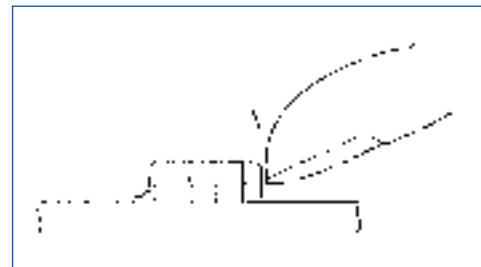

②

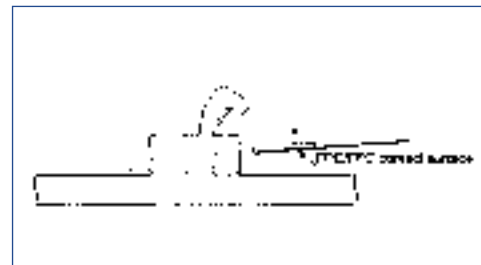

③

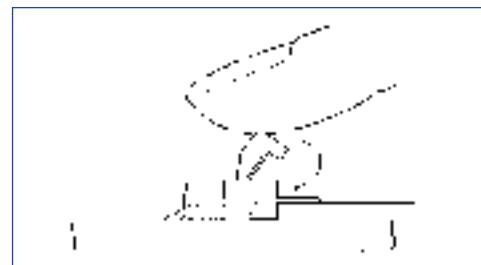

Product Specifications

Rating	Current rating: 0.5A DC(Note 1)	Operating Temperature Range: -40 to +70°C (Note 2)	Storage Temperature Range: -10 to +50°C (Note 3)
	Voltage rating: 50V AC	Operating Humidity Range: Relative humidity, 90% max. (Not dewed)	Storage Humidity Range: Relative humidity, 90% max. (Not dewed)

Applicable FPC	t=0.3±0.05 Gold plated	t=0.18 ± 0.05 for FH12F-*S-0.5SH
----------------	------------------------	----------------------------------

Item	Specification	Conditions
1. Insulation resistance	500M ohms minimum	100V DC
2. Withstanding voltage	No flashover or insulation breakdown.	150V AC/1 minute
3. Contact resistance	50m ohms maximum	1mA
4. Durability (Insertion/withdrawal)	Contact resistance: 50m ohms maximum No damage, cracks, or parts dislocation.	20 cycles
5. Vibration	No electrical discontinuity of 1μs or more Contact resistance: 50m ohms maximum. No damage, cracks, or parts dislocation.	Frequency: 10 to 55 Hz, single amplitude of 0.75 mm, 2 hours in each of the 3 directions.
6. Shock	No electrical discontinuity of 1μs or more Contact resistance: 50m ohms maximum. No damage, cracks, or parts dislocation.	Acceleration of 490 m/s ² , 11 ms duration, sine half-wave waveform, 3 cycles in each of the 3 axis.
7. Humidity(Steady state)	Contact resistance: 50m ohms maximum. Insulation resistance: 50M ohms minimum. No damage, cracks, or parts dislocation.	96 hours at 40°C and humidity of 90% to 95%
8. Temperature Cycle	Contact resistance: 50m ohms maximum. Insulation resistance: 50M ohms minimum. No damage, cracks, or parts dislocation.	Temperature: -40°C → 15 to 35°C → 85°C → 15 to 35°C, Time: 30 → 5 max. → 30 → 5 max.(minutes) 5 cycles
9. Resistance to Soldering heat	No deformation of components affecting performance.	Reflow: At the recommended temperature profile Manual soldering: 350±5°C for 3 seconds

Note 1: When passing the current through all of the contacts, use 70% of the current rating.

Note 2: Includes temperature rise caused by current flow.

Note 3: The term "storage" refers to products stored for long period of time prior to mounting and use. Operating Temperature Range and Humidity range covers nonconducting condition of installed connectors in storage, shipment or during transportation.

Material

Part	Material	Finish	Remarks
Insulator	Polyamide, LCP(60 pos.)	Color : Beige	UL94V-0
Actuator	PPS	Color : Dark brown	
Contact	Phosphor bronze	Gold plated	
Metal Fittings	Brass	Tin plated	



Ordering Information

FH12 **A** - **10** (**4**) - **S** **A** - **0.5** **SH** (**55**)
 ① ② ③ ④ ⑤ ⑥ ⑦ ⑧ ⑨

① Series Name : FH12	⑤ Contact alignment: Single
② Blank : standard type A : Top contact type S : Type with strengthened flip-lock actuator F : Type with 0.18mm FPC End Thickness	⑥ Eccentric direction: Blank : standard type A : Eccentric type
③ Standard type : Number of contacts Eccentric type : Number of contacts in 0.5mm housing	⑦ Contacts Pitch : 0.5mm, 1mm
④ Standard type : Blank Eccentric type : Number of contacts	⑧ Contact type SH : SMT horizontal mounting type SV : SMT vertical mounting type
	⑨ Plating specification (55) : Gold plated



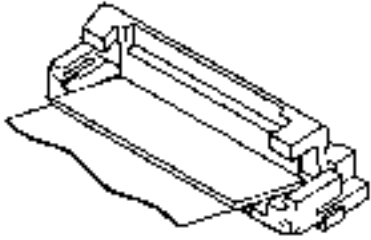

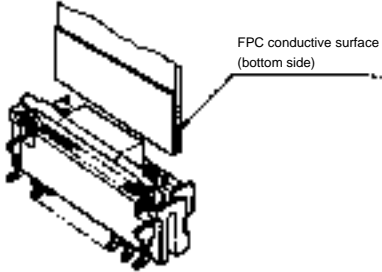
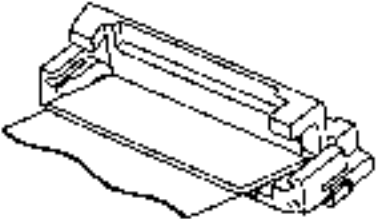
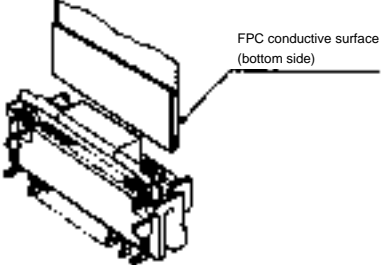
FH12 Series 0.5mm and 1mm Pitch Connectors For FPC/FPC

◆ Series Configuration

Pitch	Bottom Contact Type	Top Contact Type	Vertical mounting Type
0.5mm	 <p>FH12- ** S-0.5SH P.12 Number of contacts 6, 8, 10, 11, 12, 13, 14, 15, 16, 17, 18, 19, 20, 22, 24, 25, 26, 28, 30, 32, 33, 34, 35, 36, 40, 45, 50, 53</p>	 <p>FPC conductive surface</p>	 <p>FPC conductive surface (bottom side)</p>
	<p>Type with Strengthened Lock Lever</p>		
	<p>FH12S- ** S-0.5SH P.13 Number of contacts 30, 40, 45, 50, 53</p>		
	<p>Type with 0.18mm FPC End Thickness</p>		
1mm	 <p>Standard FH12- ** S-1SH P.18 Eccentric FH12- ** (***) SA-1SH Standard Number of contacts 5, 6, 7, 8, 9, 11, 12, 16, 17, 22, 26 Eccentric Number of contacts 4, 6, 8, 10, 11, 14, 19, 24</p>	<p>FH12A- ** S-0.5SH P.15 Number of contacts 10, 12, 15, 16, 18, 20, 22, 24, 26, 28, 29, 30, 32, 33, 34, 36, 40, 42, 45, 50</p>	<p>FH12- ** S-0.5SV P.16 Number of contacts 10, 12, 13, 15, 16, 17, 18, 20, 22, 24, 26, 30, 32, 33, 34, 36, 40, 45, 49, 50, 60</p>  <p>FPC conductive surface (bottom side)</p>
	<p>FH12- ** S-1SV P.19 Number of contacts 6, 7, 8, 16, 20, 22, 24</p>		

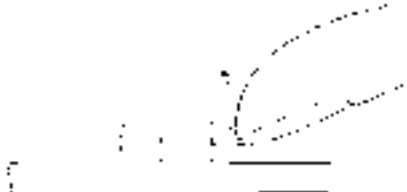
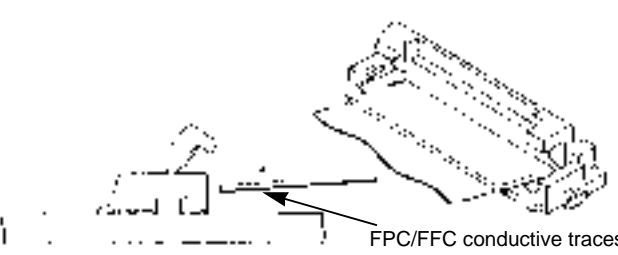
◆ Connector Operating Instructions, precautions and recommendations

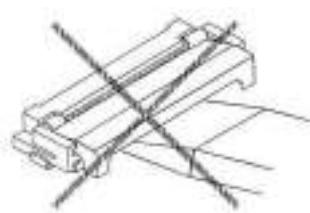
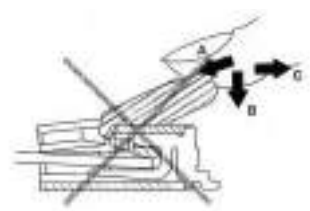

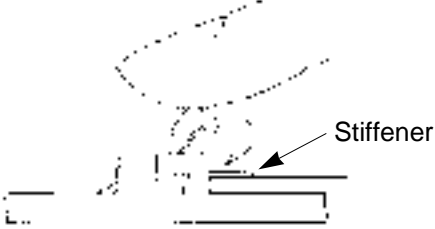
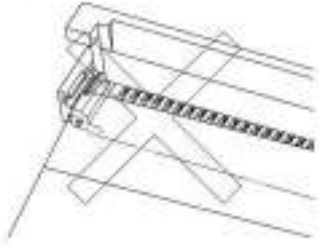
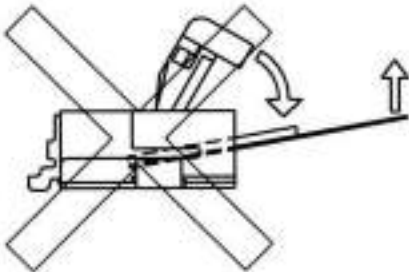
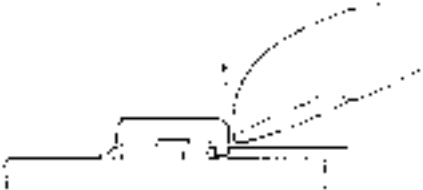
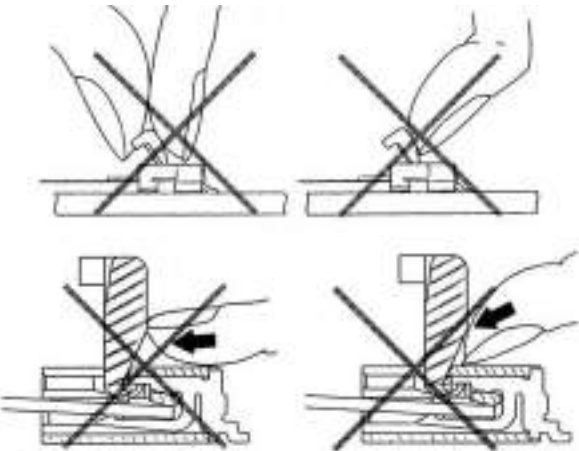

● Bottom Contact Type (common for 0.5mm/1mm)

Operation	Precautions
<p>1. FPC/FFC Termination procedure. Connector installed on the board.</p> <p>1) Lift up the actuator. Use thumb or index finger.</p>  <p>2) Fully insert the FPC/FFC parallel to mounting surface, with the exposed conductive traces facing down.</p> 	<p>1) Avoid grasping the actuator with two fingers or lifting the actuator with fingernail.</p>  <p>2) Do not use a thin tool such as the tip of a screwdriver to release the lock lever. Doing so will cause deformation of the contacts.</p>  <p>3) Do not apply force in the direction of arrows A, B, or C while the lock lever is open. Doing so will cause the lock lever to become disengaged, or will damage the hook portion of the connector body.</p>  <p>4) When inserting the FPC/FFC, do not forcefully rub against the surface beneath the connector insertion slot. Doing so will result in the FPC/FFC forcefully striking the contacts and this will cause contact deformation, peeling of the FPC/FFC conductors, and other irregularities.</p>  <p>5) Insert the FPC/FFC at the proper position of the connector insertion slot, and insert perpendicularly with respect to the connector. Improper insertion will cause continuity problems, disengagement of the lock lever, and damage to the hook portion.</p> 

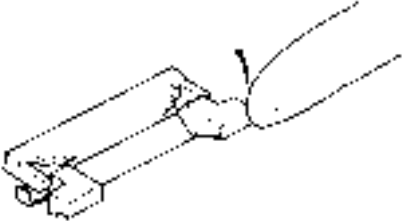
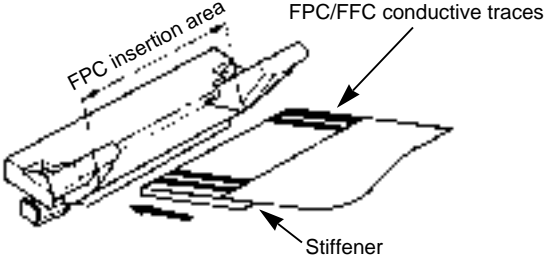
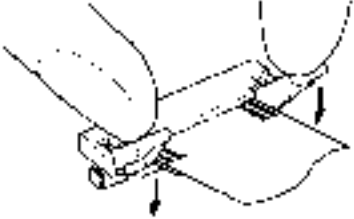

●Bottom Contact Type (common for 0.5mm/1mm)

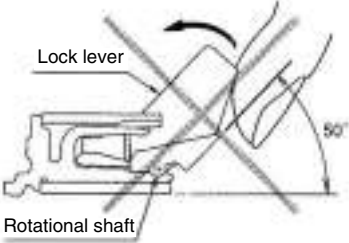
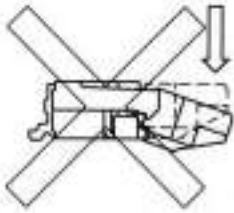
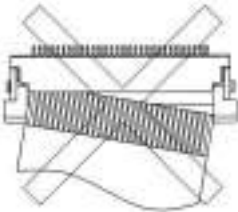
Operation	Precautions
<p>3) Rotate down the actuator until firmly closed. It is critical that the inserted FPC/FFC is not moved and remains fully inserted. Should the FPC/FFC be moved, open the actuator and repeat the process, starting with Step 1.</p> 	<p>6) Partial insertion of the FPC/FFC, offset insertion, and diagonal insertion will result in an unfavorable engagement of the lock lever in which the lock lever is raised. To correct this, first remove the FPC/FFC and then reinsert it. Forcing the lock will damage the connector.</p>  <p>7) When locking, handle the FPC/FFC so that a load is not applied to the FPC/FFC as would occur by pulling the FPC/FFC, or lifting it, etc. When a load is applied in the opposite direction to the rotational movement of the lock, an excessive load will be applied and this will cause connector damage.</p> 
<p>2. FPC/FFC Removal</p> <p>1) Lift up the actuator. 2) Carefully remove the FPC/FFC.</p> 	<p>8) At the time of lock operation, application of force such as that indicated by the arrows in the diagrams below will cause the lock lever to disengage. When the lock lever has become disengaged, please exchange the entire connector.</p> 

● Top Contact Type

Operation	Precautions
<p>1. FPC/FFC Termination procedure. Connector installed on the board.</p> <p>1) Lift up the actuator. Use thumb or index finger.</p>  <p>2) Fully insert the FPC/FFC parallel to mounting surface, with the exposed conductive traces facing UP.</p>  <p>3) Rotate down the actuator until firmly closed. It is critical that the inserted FPC/FFC is not moved and remains fully inserted. Should the FPC/FFC be moved, open the actuator and repeat the process, starting with Step 1 above.</p>  <p>2. FPC/FFC Removal</p> <p>1) Lift up the actuator. 2) Carefully remove the FPC/FFC.</p> 	<p>1) Avoid further lifting of the lock lever once the lock has been released. Doing so will cause the lock lever to separate from the rotational shaft, and the lock lever will become disengaged or the hook portion of the connector body will be damaged</p>  <p>2) Avoid further pressing of the lock portion from the locked condition when the FPC/FFC has not yet been inserted. Doing so will cause the lock lever to become disengaged from the rotational shaft, and the hook portion of the connector body will be damaged.</p>  <p>3) Do not insert the FPC/FFC diagonally. Doing so will result in the corners of the FPC/FFC catching on the contacts and will cause deformation of the contacts.</p>  <p>4) When closing down the actuator apply equal pressure to both sides of the actuator.</p> 

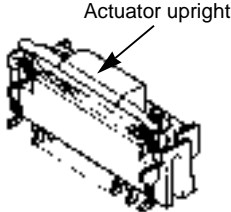
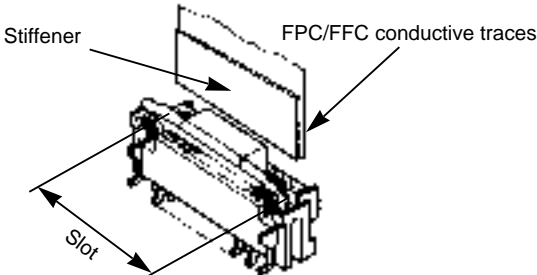
● Vertical Mounting Type

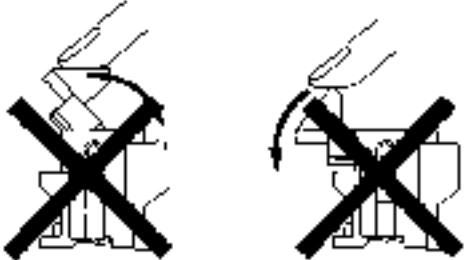
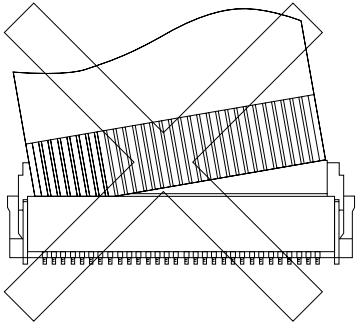
Operation	Precautions
<p>1. FPC/FFC Termination procedure. Connector installed on the board.</p> <p>1) Verify that the actuator is positioned upright. If the actuator has rotated to the side, carefully rotate it upright.</p>  <p>2) Insert the FPC/FFC vertically in the connector slot assuring that the conductive traces of the FPC/FFC are facing away from the actuator.</p>  <p>3) Press down the actuator in the direction shown.</p>  <p>2. FPC/FFC Removal Rotate the actuator upward and withdraw the FPC/FFC.</p> 	<p>1) Avoid forcing the actuator up or down without the FPC/FFC inserted.</p>  <p>2) Do not insert the FPC/FFC diagonally. Doing so will result in the corners of the FPC/FFC catching on the contacts and will cause deformation of the contacts.</p> 

0.5mm Pitch Bottom Contact Type

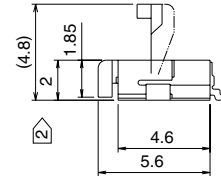
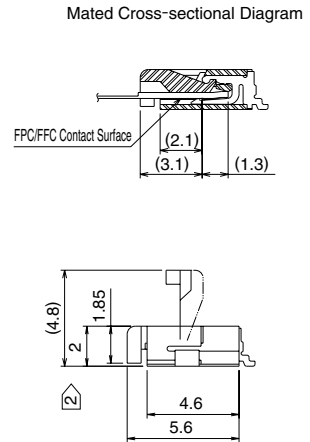
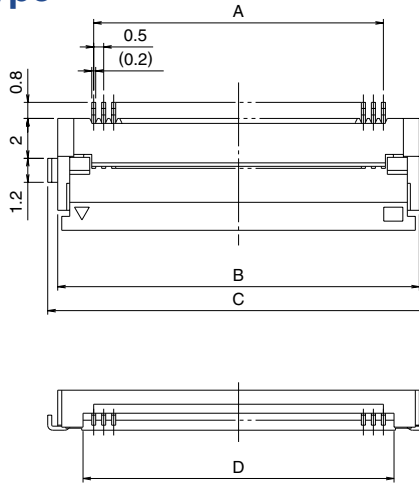

Unit:mm

Part Number	CL No.	Number of Contacts	A	B	C	D	RoHS
FH12- 6S-0.5SH(55)	586-0582-5-55	6	2.5	6.1	7.1	3.57	YES
FH12- 8S-0.5SH(55)	586-0744-5-55	8	3.5	7.1	8.1	4.57	
FH12-10S-0.5SH(55)	586-0522-3-55	10	4.5	8.1	9.1	5.57	
FH12-11S-0.5SH(55)	586-0600-5-55	11	5	8.6	9.6	6.07	
FH12-12S-0.5SH(55)	586-0704-0-55	12	5.5	9.1	10.1	6.57	
FH12-13S-0.5SH(55)	586-0549-0-55	13	6	9.6	10.6	7.07	
FH12-14S-0.5SH(55)	586-0533-0-55	14	6.5	10.1	11.1	7.57	
FH12-15S-0.5SH(55)	586-0523-6-55	15	7	10.6	11.6	8.07	
FH12-16S-0.5SH(55)	586-0531-4-55	16	7.5	11.1	12.1	8.57	
FH12-17S-0.5SH(55)	586-0606-1-55	17	8	11.6	12.6	9.07	
FH12-18S-0.5SH(55)	586-0530-1-55	18	8.5	12.1	13.1	9.57	
FH12-19S-0.5SH(55)	586-0534-2-55	19	9	12.6	13.6	10.07	
FH12-20S-0.5SH(55)	586-0524-9-55	20	9.5	13.1	14.1	10.57	
FH12-22S-0.5SH(55)	586-0532-7-55	22	10.5	14.1	15.1	11.57	
FH12-24S-0.5SH(55)	586-0521-0-55	24	11.5	15.1	16.1	12.57	
FH12-25S-0.5SH(55)	586-0692-3-55	25	12	15.6	16.6	13.07	
FH12-26S-0.5SH(55)	586-0576-2-55	26	12.5	16.1	17.1	13.57	
FH12-28S-0.5SH(55)	586-0612-4-55	28	13.5	17.1	18.1	14.57	
Note ② FH12-30S-0.5SH(55)	586-0525-1-55	30	14.5	18.1	19.1	15.57	
FH12-32S-0.5SH(55)	586-0681-7-55	32	15.5	19.1	20.1	16.57	
FH12-33S-0.5SH(55)	586-0520-8-55	33	16	19.6	20.6	17.07	
FH12-34S-0.5SH(55)	586-0617-8-55	34	16.5	20.1	21.1	17.57	
FH12-35S-0.5SH(55)	586-0740-4-55	35	17.0	20.6	21.6	18.07	
FH12-36S-0.5SH(55)	586-0526-4-55	36	17.5	21.1	22.1	18.57	
Note ② FH12-40S-0.5SH(55)	586-0527-7-55	40	19.5	23.1	24.1	20.57	
Note ② FH12-45S-0.5SH(55)	586-0528-0-55	45	22	25.6	26.6	23.07	
Note ② FH12-50S-0.5SH(55)	586-0529-2-55	50	24.5	28.1	29.1	25.57	
Note ② FH12-53S-0.5SH(55)	586-0595-7-55	53	26	29.6	30.6	27.07	

Note 1 : Embossed tape reel packaging (2,000 pieces/reel).
 Order by number of reels.

Note ② : If there is no problem with the connector height, we recommend the type with the strengthened Flip-lock actuator (FH12S-*S-0.5SH).
 Standard type connector height: 2 mm
 Connector height of type with strengthened Flip-lock actuator: 2.4 mm

FH12 Series 0.5mm and 1mm Pitch Connectors For FPC/FFC

0.5mm Pitch Bottom Contact Type with Strengthened Flip-lock Actuator

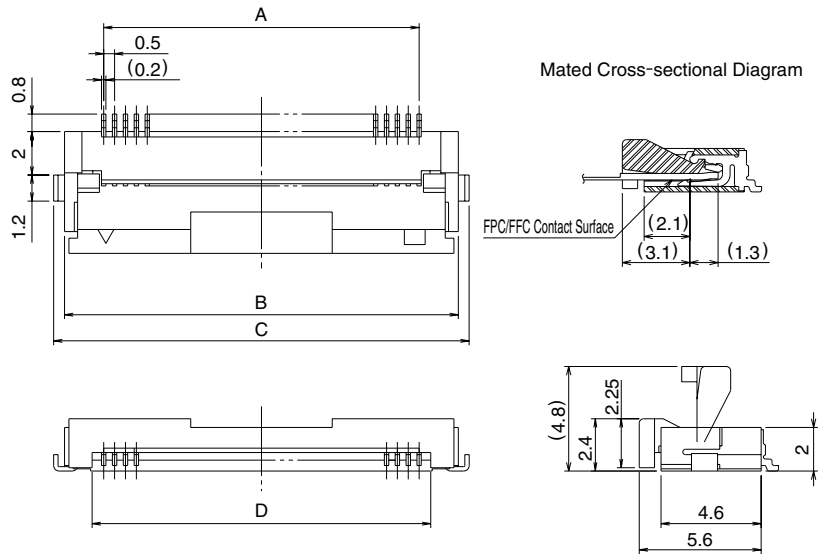

Unit:mm

Part Number	CL No.	Number of Contacts	A	B	C	D	RoHS
FH12S-30S-0.5SH(55)	586-0667-6-55	30	14.5	18.1	19.1	15.57	YES
FH12S-40S-0.5SH(55)	586-0640-0-55	40	19.5	23.1	24.1	20.57	
FH12S-45S-0.5SH(55)	586-0665-0-55	45	22.0	25.6	26.6	23.07	
FH12S-50S-0.5SH(55)	586-0642-5-55	50	24.5	28.1	29.1	25.57	
FH12S-53S-0.5SH(55)	586-0691-0-55	53	26.0	29.6	30.6	27.07	

Note 1 Embossed tape reel packaging (2,000 pieces/reel).
 Order by number of reels.

0.5mm Pitch Bottom Contact Type with 0.18mm FPC End Thickness

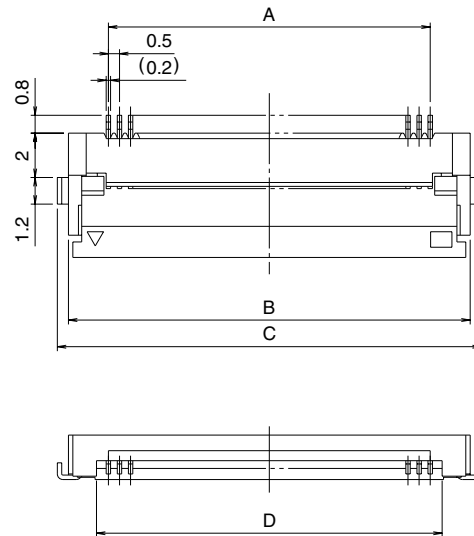

Applicable FPC end thickness : 0.18 ± 0.05

Mated Cross-sectional Diagram

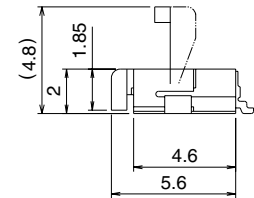
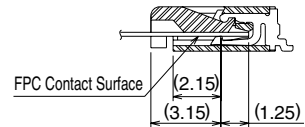

Unit:mm

Part Number	CL No.	Number of Contacts	A	B	C	D	RoHS
FH12F- 6S-0.5SH(55)	586-0672-6-55	6	2.5	6.1	7.1	3.57	YES
FH12F- 8S-0.5SH(55)	586-0738-2-55	8	3.5	7.1	8.1	4.57	
FH12F-10S-0.5SH(55)	586-0709-4-55	10	4.5	8.1	9.1	5.57	
FH12F-12S-0.5SH(55)	586-0653-1-55	12	5.5	9.1	10.1	6.57	
FH12F-13S-0.5SH(55)	586-0629-7-55	13	6.0	9.6	10.6	7.07	
FH12F-14S-0.5SH(55)	586-0655-7-55	14	6.5	10.1	11.1	7.57	
FH12F-15S-0.5SH(55)	586-0680-4-55	15	7.0	10.6	11.6	8.07	
FH12F-16S-0.5SH(55)	586-0673-9-55	16	7.5	11.1	12.1	8.57	
FH12F-18S-0.5SH(55)	586-0626-9-55	18	8.5	12.1	13.1	9.57	
FH12F-20S-0.5SH(55)	586-0636-2-55	20	9.5	13.1	14.1	10.57	
FH12F-22S-0.5SH(55)	586-0630-6-55	22	10.5	14.1	15.1	11.57	
FH12F-24S-0.5SH(55)	586-0632-1-55	24	11.5	15.1	16.1	12.57	
FH12F-25S-0.5SH(55)	586-0733-9-55	25	12.0	15.6	16.6	13.07	
FH12F-26S-0.5SH(55)	586-0627-1-55	26	12.5	16.1	17.1	13.57	
FH12F-28S-0.5SH(55)	586-0643-8-55	28	13.5	17.1	18.1	14.57	
FH12F-30S-0.5SH(55)	586-0628-4-55	30	14.5	18.1	19.1	15.57	
FH12F-32S-0.5SH(55)	586-0705-3-55	32	15.5	19.1	20.1	16.57	
FH12F-34S-0.5SH(55)	586-0677-0-55	34	16.5	20.1	21.1	17.57	
FH12F-36S-0.5SH(55)	586-0656-0-55	36	17.5	21.1	22.1	18.57	
FH12F-40S-0.5SH(55)	586-0635-0-55	40	19.5	23.1	24.1	20.57	

Note 1 : Embossed tape reel packaging (2,000 pieces/reel).
 Order by number of reels.

FH12 Series 0.5mm and 1mm Pitch Connectors For FPC/FFC

0.5mm Pitch Top Contact Type

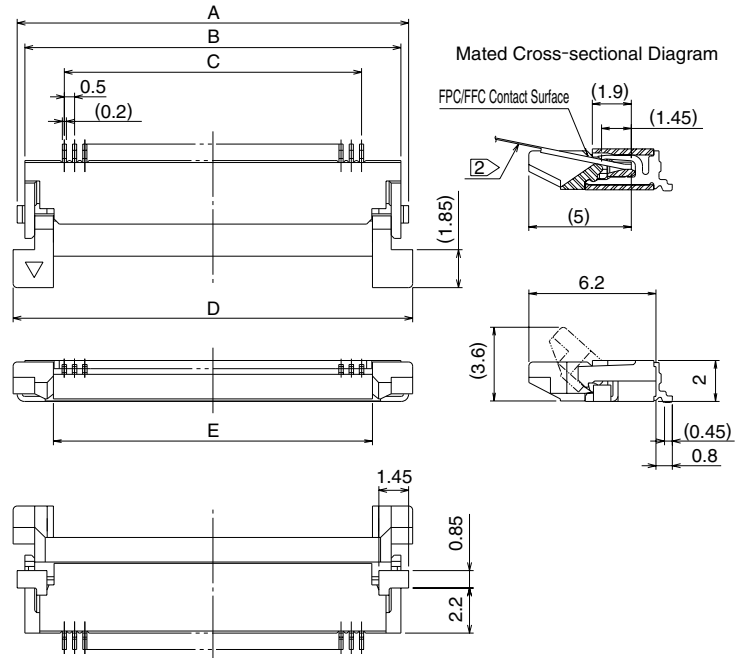

Unit:mm

Part Number	CL No.	Number of Contacts	A	B	C	D	E	RoHS
FH12A-10S-0.5SH(55)	586-0550-9-55	10	9.1	8.35	4.5	9.5	5.57	YES
FH12A-12S-0.5SH(55)	586-0696-4-55	12	10.1	9.35	5.5	10.5	6.57	
FH12A-15S-0.5SH(55)	586-0551-1-55	15	11.6	10.85	7.0	12.0	8.07	
FH12A-16S-0.5SH(55)	586-0552-4-55	16	12.1	11.35	7.5	12.5	8.57	
FH12A-18S-0.5SH(55)	586-0553-7-55	18	13.1	12.35	8.5	13.5	9.57	
FH12A-20S-0.5SH(55)	586-0554-0-55	20	14.1	13.35	9.5	14.5	10.57	
FH12A-22S-0.5SH(55)	586-0686-0-55	22	15.1	14.35	10.5	15.5	11.57	
FH12A-24S-0.5SH(55)	586-0555-2-55	24	16.1	15.35	11.5	16.5	12.57	
FH12A-26S-0.5SH(55)	586-0663-5-55	26	17.1	16.35	12.5	17.5	13.57	
FH12A-28S-0.5SH(55)	586-0725-0-55	28	18.1	17.35	13.5	18.5	14.57	
FH12A-29S-0.5SH(55)	586-0585-3-55	29	18.6	17.85	14.0	19.0	15.07	
FH12A-30S-0.5SH(55)	586-0556-5-55	30	19.1	18.35	14.5	19.5	15.57	
FH12A-32S-0.5SH(55)	586-0687-3-55	32	20.1	19.35	15.5	20.5	16.57	
FH12A-33S-0.5SH(55)	586-0570-6-55	33	20.6	19.85	16.0	21.0	17.07	
FH12A-34S-0.5SH(55)	586-0670-0-55	34	21.1	20.35	16.5	21.5	17.57	
FH12A-36S-0.5SH(55)	586-0662-2-55	36	22.1	21.35	17.5	22.5	18.57	
FH12A-40S-0.5SH(55)	586-0557-8-55	40	24.1	23.35	19.5	24.5	20.57	
FH12A-42S-0.5SH(55)	586-0698-0-55	42	25.1	24.35	20.5	25.5	21.57	
FH12A-45S-0.5SH(55)	586-0558-0-55	45	26.6	25.85	22.0	27.0	23.07	
FH12A-50S-0.5SH(55)	586-0559-3-55	50	29.1	28.35	24.5	29.5	25.57	

Note 1 : Embossed tape reel packaging (2,000 pieces/reel).

Order by number of reels.

Note 2: The design is such that the FPC/FFC protrudes on an upward angle so that other parts can be mounted beneath the PFC/FFC. In view of this, please take note of the gap at the top surface of the connector.

0.5mm Pitch Vertical mounting Type

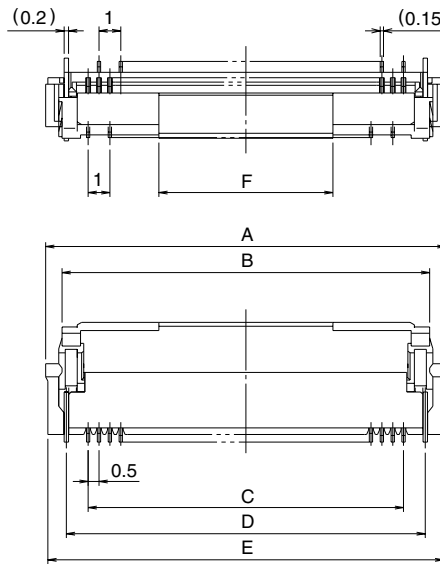

Mated Cross-sectional Diagram

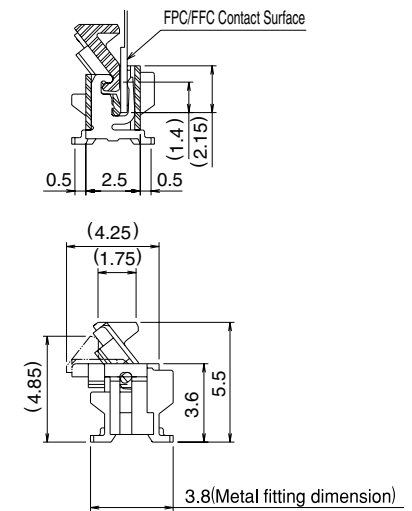

Unit:mm

Part Number	CL No.	Number of Contacts	A	B	C	D	E	F	RoHS
FH12-10S-0.5SV(55)	586-0560-2-55	10	8.4	6.9	4.5	6.5	8.2	4	YES
FH12-12S-0.5SV(55)	586-0615-2-55	12	9.4	7.9	5.5	7.5	9.2	4	
FH12-13S-0.5SV(55)	586-0575-0-55	13	9.9	8.4	6.0	8.0	9.7	4	
FH12-15S-0.5SV(55)	586-0561-5-55	15	10.9	9.4	7.0	9.0	10.7	4	
FH12-16S-0.5SV(55)	586-0572-1-55	16	11.4	9.9	7.5	9.5	11.2	4	
FH12-17S-0.5SV(55)	586-0601-8-55	17	11.9	10.4	8.0	10.0	11.7	4	
FH12-18S-0.5SV(55)	586-0573-4-55	18	12.4	10.9	8.5	10.5	12.2	4	
FH12-20S-0.5SV(55)	586-0562-8-55	20	13.4	11.9	9.5	11.5	13.2	4	
FH12-22S-0.5SV(55)	586-0589-4-55	22	14.4	12.9	10.5	12.5	14.2	8	
FH12-24S-0.5SV(55)	586-0563-0-55	24	15.4	13.9	11.5	13.5	15.2	8	
FH12-26S-0.5SV(55)	586-0664-8-55	26	16.4	14.9	12.5	14.5	16.2	8	
FH12-30S-0.5SV(55)	586-0564-3-55	30	18.4	16.9	14.5	16.5	18.2	8	
FH12-32S-0.5SV(55)	586-0699-2-55	32	19.4	17.9	15.5	17.5	19.2	8	
FH12-33S-0.5SV(55)	586-0565-6-55	33	19.9	18.4	16.0	18.0	19.7	8	
FH12-34S-0.5SV(55)	586-0706-6-55	34	20.4	18.9	16.5	18.5	20.2	8	
FH12-36S-0.5SV(55)	586-0641-2-55	36	21.4	19.9	17.5	19.5	21.2	8	
FH12-40S-0.5SV(55)	586-0566-9-55	40	23.4	21.9	19.5	21.5	23.2	8	
FH12-45S-0.5SV(55)	586-0567-1-55	45	25.9	24.4	22.0	24.0	25.7	8	
FH12-49S-0.5SV(55)	586-0602-0-55	49	27.9	26.4	24.0	26.0	27.7	8	
FH12-50S-0.5SV(55)	586-0568-4-55	50	28.4	26.9	24.5	26.5	28.2	8	
FH12-60S-0.5SV(55)	586-0735-4-55	60	33.4	31.9	29.5	31.5	33.2	8	

Note 1 : Embossed tape reel packaging (1,000 pieces/reel).
 Order by number of reels.

FH12 Series 0.5mm and 1mm Pitch Connectors For FPC/FFC

1mm Pitch Type Bottom Contact Type

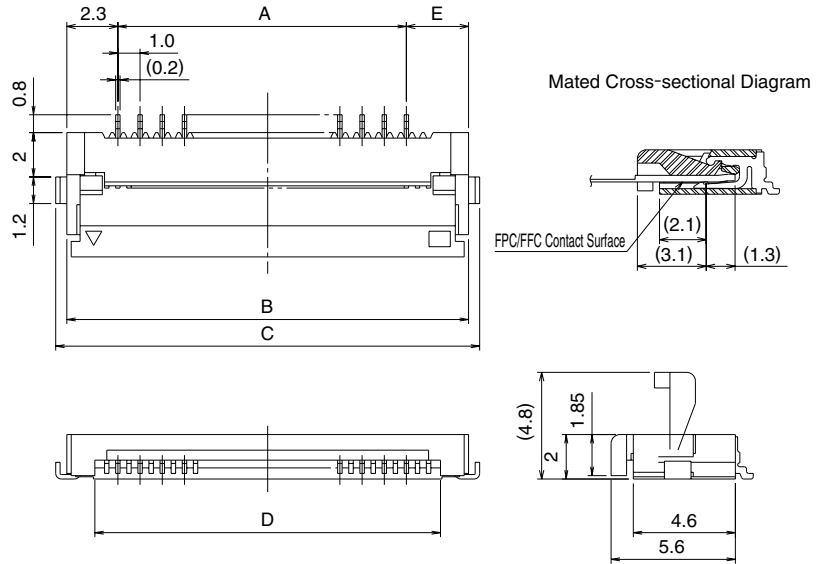

Unit:mm

	Part Number	CL No.	Number of Contacts	A	B	C	D	E	RoHS
Standard type	FH12- 5S-1SH(55)	586-0591-6-55	5	4	8.6	9.6	6.07	2.3	YES
	FH12- 6S-1SH(55)	586-0607-4-55	6	5	9.6	10.6	7.07	2.3	
	FH12- 7S-1SH(55)	586-0535-5-55	7	6	10.6	11.6	8.07	2.3	
	FH12- 8S-1SH(55)	586-0579-0-55	8	7	11.6	12.6	9.07	2.3	
	FH12- 9S-1SH(55)	586-0540-5-55	9	8	12.6	13.6	10.07	2.3	
	FH12-11S-1SH(55)	586-0668-9-55	11	10	14.6	15.6	12.07	2.3	
	FH12-12S-1SH(55)	586-0741-7-55	12	11	15.6	16.6	13.07	2.3	
	FH12-16S-1SH(55)	586-0536-8-55	16	15	19.6	20.6	17.07	2.3	
	FH12-17S-1SH(55)	586-0739-5-55	17	16	20.6	21.6	18.07	2.3	
	FH12-22S-1SH(55)	586-0547-4-55	22	21	25.6	26.6	23.07	2.3	
FH12-26S-1SH(55)	586-0592-9-55	26	25	29.6	30.6	27.07	2.3		
Eccentric type	FH12-10(4)SA-1SH(55)	586-0537-0-55	4	3	8.1	9.1	5.57	2.8	
	FH12-14(6)SA-1SH(55)	586-0538-3-55	6	5	10.1	11.1	7.57	2.8	
	FH12-18(8)SA-1SH(55)	586-0539-6-55	8	7	12.1	13.1	9.57	2.8	
	FH12-22(10)SA-1SH(55)	586-0541-8-55	10	9	14.1	15.1	11.57	2.8	
	FH12-24(11)SA-1SH(55)	586-0542-0-55	11	10	15.1	16.1	12.57	2.8	
	FH12-30(14)SA-1SH(55)	586-0543-3-55	14	13	18.1	19.1	15.57	2.8	
	FH12-40(19)SA-1SH(55)	586-0546-1-55	19	18	23.1	24.1	20.57	2.8	
	FH12-50(24)SA-1SH(55)	586-0548-7-55	24	23	28.1	29.1	25.57	2.8	

Note 1: Embossed tape reel packaging (2,000 pieces/reel).

Order by number of reels.

Note 2: The 1mm version of FH12 is constructed by loading every other contact into the 0.5mm housing.

When a housing designed for an odd number of 0.5mm pitch contacts is used; the spacing from the edge to the first contact on either side is the same as the distance between each contact, 1.0mm.

Hirose considers this design to be a **standard-type 1.0mm** connector.

An **eccentric-type** connector using a housing designed for an even number of 0.5mm pitch contacts and consequently one side has 1.5mm distance from the edge to the first contact. (See FPC/FFC dimensional drawing on page 19) The part number for the eccentric type describes the size of the 0.5mm housing used and lists the number of 1.0mm pitch contacts in parentheses () as shown in the above table.

1mm Pitch Vertical Mounting Type

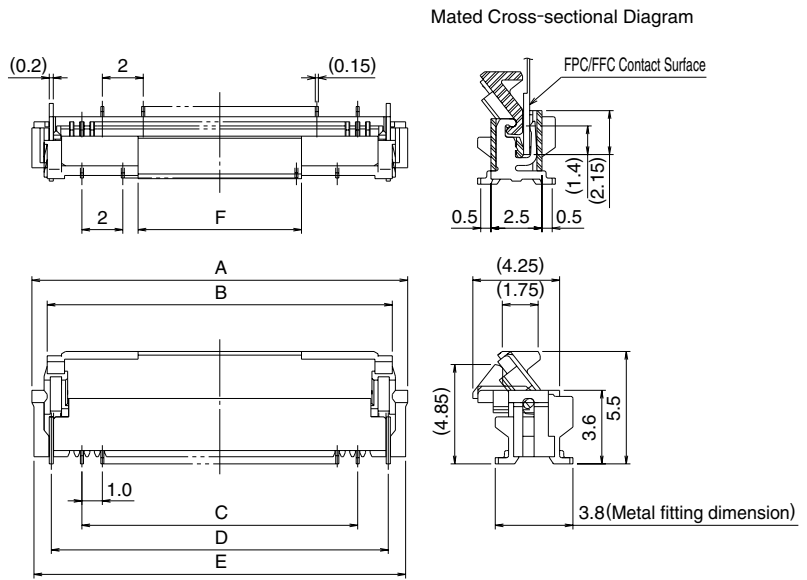

Unit:mm

Part Number	CL No.	Number of Contacts	A	B	C	D	E	F	RoHS
FH12- 6S-1SV(55)	586-0605-9-55	6	9.9	8.4	5	8	9.7	4	YES
FH12- 7S-1SV(55)	586-0610-9-55	7	10.9	9.4	6	9	10.7	4	
FH12- 8S-1SV(55)	586-0593-1-55	8	11.9	10.4	7	10	11.7	4	
FH12-16S-1SV(55)	586-0574-7-55	16	19.9	18.4	15	18	19.7	8	
FH12-20S-1SV(55)	586-0634-7-55	20	23.9	22.4	19	22	23.7	8	
FH12-22S-1SV(55)	586-0584-0-55	22	25.9	24.4	21	24	25.7	8	
FH12-24S-1SV(55)	586-0594-4-55	24	27.9	26.4	23	26	27.7	8	

Note 1: Embossed tape reel packaging (1,000 pieces/reel).
 Order by number of reels.



◆ Recommended FPC/FFC dimensions and Land/Metal Mask dimensions

● 0.5mm Pitch Product

	FPC/FFC dimensions	Land / Metal Mask dimensions																																																																																																																																																																																																																																								
0.5mm Pitch Bottom Contact Type 0.5mm Pitch Top Contact Type	<table border="1"> <tr> <td>Product Type</td> <td>C Dimension</td> </tr> <tr> <td>Types other than those below</td> <td>0.3±0.05min</td> </tr> <tr> <td></td> <td>Stiffener thickness should be 0.188 mm (7.5 mil) min</td> </tr> <tr> <td>FH12F</td> <td>0.18±0.05</td> </tr> </table> <p style="text-align: right;">Unit: mm</p> <table border="1"> <thead> <tr> <th>Dimension</th> <th>A</th> <th>B</th> <th>Dimension</th> <th>A</th> <th>B</th> </tr> </thead> <tbody> <tr><td>6</td><td>2.5</td><td>3.5</td><td>25</td><td>12.0</td><td>13.0</td></tr> <tr><td>8</td><td>3.5</td><td>4.5</td><td>26</td><td>12.5</td><td>13.5</td></tr> <tr><td>10</td><td>4.5</td><td>5.5</td><td>28</td><td>13.5</td><td>14.5</td></tr> <tr><td>11</td><td>5.0</td><td>6.0</td><td>29</td><td>14.0</td><td>15.0</td></tr> <tr><td>12</td><td>5.5</td><td>6.5</td><td>30</td><td>14.5</td><td>15.5</td></tr> <tr><td>13</td><td>6.0</td><td>7.0</td><td>32</td><td>15.5</td><td>16.5</td></tr> <tr><td>14</td><td>6.5</td><td>7.5</td><td>33</td><td>16.0</td><td>17.0</td></tr> <tr><td>15</td><td>7.0</td><td>8.0</td><td>34</td><td>16.5</td><td>17.5</td></tr> <tr><td>16</td><td>7.5</td><td>8.5</td><td>35</td><td>17.0</td><td>18.0</td></tr> <tr><td>17</td><td>8.0</td><td>9.0</td><td>36</td><td>17.5</td><td>18.5</td></tr> <tr><td>18</td><td>8.5</td><td>9.5</td><td>40</td><td>19.5</td><td>20.5</td></tr> <tr><td>19</td><td>9.0</td><td>10.0</td><td>42</td><td>20.5</td><td>21.5</td></tr> <tr><td>20</td><td>9.5</td><td>10.5</td><td>45</td><td>22.0</td><td>23.0</td></tr> <tr><td>22</td><td>10.5</td><td>11.5</td><td>50</td><td>24.5</td><td>25.5</td></tr> <tr><td>24</td><td>11.5</td><td>12.5</td><td>53</td><td>26.0</td><td>27.0</td></tr> </tbody> </table>	Product Type	C Dimension	Types other than those below	0.3±0.05min		Stiffener thickness should be 0.188 mm (7.5 mil) min	FH12F	0.18±0.05	Dimension	A	B	Dimension	A	B	6	2.5	3.5	25	12.0	13.0	8	3.5	4.5	26	12.5	13.5	10	4.5	5.5	28	13.5	14.5	11	5.0	6.0	29	14.0	15.0	12	5.5	6.5	30	14.5	15.5	13	6.0	7.0	32	15.5	16.5	14	6.5	7.5	33	16.0	17.0	15	7.0	8.0	34	16.5	17.5	16	7.5	8.5	35	17.0	18.0	17	8.0	9.0	36	17.5	18.5	18	8.5	9.5	40	19.5	20.5	19	9.0	10.0	42	20.5	21.5	20	9.5	10.5	45	22.0	23.0	22	10.5	11.5	50	24.5	25.5	24	11.5	12.5	53	26.0	27.0	<p style="text-align: center;">Recommended metal mask thickness : 0.15mm</p> <p style="text-align: right;">Unit: mm</p> <table border="1"> <thead> <tr> <th>Dimension</th> <th>A</th> <th>B</th> <th>C</th> <th>Dimension</th> <th>A</th> <th>B</th> <th>C</th> </tr> </thead> <tbody> <tr><td>6</td><td>2.5</td><td>8.1</td><td>4.5</td><td>25</td><td>12.0</td><td>17.6</td><td>14.0</td></tr> <tr><td>8</td><td>3.5</td><td>9.1</td><td>5.5</td><td>26</td><td>12.5</td><td>18.1</td><td>14.5</td></tr> <tr><td>10</td><td>4.5</td><td>10.1</td><td>6.5</td><td>28</td><td>13.5</td><td>19.1</td><td>15.5</td></tr> <tr><td>11</td><td>5.0</td><td>10.6</td><td>7.0</td><td>29</td><td>14.0</td><td>19.6</td><td>16.0</td></tr> <tr><td>12</td><td>5.5</td><td>11.1</td><td>7.5</td><td>30</td><td>14.5</td><td>20.1</td><td>16.5</td></tr> <tr><td>13</td><td>6.0</td><td>11.6</td><td>8.0</td><td>32</td><td>15.5</td><td>21.1</td><td>17.5</td></tr> <tr><td>14</td><td>6.5</td><td>12.1</td><td>8.5</td><td>33</td><td>16.0</td><td>21.6</td><td>18.0</td></tr> <tr><td>15</td><td>7.0</td><td>12.6</td><td>9.0</td><td>34</td><td>16.5</td><td>22.1</td><td>18.5</td></tr> <tr><td>16</td><td>7.5</td><td>13.1</td><td>9.5</td><td>35</td><td>17.0</td><td>22.6</td><td>19.0</td></tr> <tr><td>17</td><td>8.0</td><td>13.6</td><td>10.0</td><td>36</td><td>17.5</td><td>23.1</td><td>19.5</td></tr> <tr><td>18</td><td>8.5</td><td>14.1</td><td>10.5</td><td>40</td><td>19.5</td><td>25.1</td><td>21.5</td></tr> <tr><td>19</td><td>9.0</td><td>14.6</td><td>11.0</td><td>42</td><td>20.5</td><td>26.1</td><td>22.5</td></tr> <tr><td>20</td><td>9.5</td><td>15.1</td><td>11.5</td><td>45</td><td>22.0</td><td>27.6</td><td>24.0</td></tr> <tr><td>22</td><td>10.5</td><td>16.1</td><td>12.5</td><td>50</td><td>24.5</td><td>30.1</td><td>26.5</td></tr> <tr><td>24</td><td>11.5</td><td>17.1</td><td>13.5</td><td>53</td><td>26.0</td><td>31.6</td><td>28.0</td></tr> </tbody> </table>	Dimension	A	B	C	Dimension	A	B	C	6	2.5	8.1	4.5	25	12.0	17.6	14.0	8	3.5	9.1	5.5	26	12.5	18.1	14.5	10	4.5	10.1	6.5	28	13.5	19.1	15.5	11	5.0	10.6	7.0	29	14.0	19.6	16.0	12	5.5	11.1	7.5	30	14.5	20.1	16.5	13	6.0	11.6	8.0	32	15.5	21.1	17.5	14	6.5	12.1	8.5	33	16.0	21.6	18.0	15	7.0	12.6	9.0	34	16.5	22.1	18.5	16	7.5	13.1	9.5	35	17.0	22.6	19.0	17	8.0	13.6	10.0	36	17.5	23.1	19.5	18	8.5	14.1	10.5	40	19.5	25.1	21.5	19	9.0	14.6	11.0	42	20.5	26.1	22.5	20	9.5	15.1	11.5	45	22.0	27.6	24.0	22	10.5	16.1	12.5	50	24.5	30.1	26.5	24	11.5	17.1	13.5	53	26.0	31.6	28.0
	Product Type	C Dimension																																																																																																																																																																																																																																								
Types other than those below	0.3±0.05min																																																																																																																																																																																																																																									
	Stiffener thickness should be 0.188 mm (7.5 mil) min																																																																																																																																																																																																																																									
FH12F	0.18±0.05																																																																																																																																																																																																																																									
Dimension	A	B	Dimension	A	B																																																																																																																																																																																																																																					
6	2.5	3.5	25	12.0	13.0																																																																																																																																																																																																																																					
8	3.5	4.5	26	12.5	13.5																																																																																																																																																																																																																																					
10	4.5	5.5	28	13.5	14.5																																																																																																																																																																																																																																					
11	5.0	6.0	29	14.0	15.0																																																																																																																																																																																																																																					
12	5.5	6.5	30	14.5	15.5																																																																																																																																																																																																																																					
13	6.0	7.0	32	15.5	16.5																																																																																																																																																																																																																																					
14	6.5	7.5	33	16.0	17.0																																																																																																																																																																																																																																					
15	7.0	8.0	34	16.5	17.5																																																																																																																																																																																																																																					
16	7.5	8.5	35	17.0	18.0																																																																																																																																																																																																																																					
17	8.0	9.0	36	17.5	18.5																																																																																																																																																																																																																																					
18	8.5	9.5	40	19.5	20.5																																																																																																																																																																																																																																					
19	9.0	10.0	42	20.5	21.5																																																																																																																																																																																																																																					
20	9.5	10.5	45	22.0	23.0																																																																																																																																																																																																																																					
22	10.5	11.5	50	24.5	25.5																																																																																																																																																																																																																																					
24	11.5	12.5	53	26.0	27.0																																																																																																																																																																																																																																					
Dimension	A	B	C	Dimension	A	B	C																																																																																																																																																																																																																																			
6	2.5	8.1	4.5	25	12.0	17.6	14.0																																																																																																																																																																																																																																			
8	3.5	9.1	5.5	26	12.5	18.1	14.5																																																																																																																																																																																																																																			
10	4.5	10.1	6.5	28	13.5	19.1	15.5																																																																																																																																																																																																																																			
11	5.0	10.6	7.0	29	14.0	19.6	16.0																																																																																																																																																																																																																																			
12	5.5	11.1	7.5	30	14.5	20.1	16.5																																																																																																																																																																																																																																			
13	6.0	11.6	8.0	32	15.5	21.1	17.5																																																																																																																																																																																																																																			
14	6.5	12.1	8.5	33	16.0	21.6	18.0																																																																																																																																																																																																																																			
15	7.0	12.6	9.0	34	16.5	22.1	18.5																																																																																																																																																																																																																																			
16	7.5	13.1	9.5	35	17.0	22.6	19.0																																																																																																																																																																																																																																			
17	8.0	13.6	10.0	36	17.5	23.1	19.5																																																																																																																																																																																																																																			
18	8.5	14.1	10.5	40	19.5	25.1	21.5																																																																																																																																																																																																																																			
19	9.0	14.6	11.0	42	20.5	26.1	22.5																																																																																																																																																																																																																																			
20	9.5	15.1	11.5	45	22.0	27.6	24.0																																																																																																																																																																																																																																			
22	10.5	16.1	12.5	50	24.5	30.1	26.5																																																																																																																																																																																																																																			
24	11.5	17.1	13.5	53	26.0	31.6	28.0																																																																																																																																																																																																																																			
0.5mm Pitch Vertical Mounting Type	<p style="text-align: center;">*Set the stiffener thickness to 0.188 (7.5mil) min.</p> <p style="text-align: right;">Unit: mm</p> <table border="1"> <thead> <tr> <th>Dimension</th> <th>A</th> <th>B</th> <th>Dimension</th> <th>A</th> <th>B</th> </tr> </thead> <tbody> <tr><td>10</td><td>4.5</td><td>5.5</td><td>26</td><td>12.5</td><td>13.5</td></tr> <tr><td>12</td><td>5.5</td><td>6.5</td><td>30</td><td>14.5</td><td>15.5</td></tr> <tr><td>13</td><td>6.0</td><td>7.0</td><td>32</td><td>15.5</td><td>16.5</td></tr> <tr><td>15</td><td>7.0</td><td>8.0</td><td>33</td><td>16.0</td><td>17.0</td></tr> <tr><td>16</td><td>7.5</td><td>8.5</td><td>34</td><td>16.5</td><td>17.5</td></tr> <tr><td>17</td><td>8.0</td><td>9.0</td><td>36</td><td>17.5</td><td>18.5</td></tr> <tr><td>18</td><td>8.5</td><td>9.5</td><td>40</td><td>19.5</td><td>20.5</td></tr> <tr><td>20</td><td>9.5</td><td>10.5</td><td>45</td><td>22.0</td><td>23.0</td></tr> <tr><td>22</td><td>10.5</td><td>11.5</td><td>49</td><td>24.0</td><td>25.0</td></tr> <tr><td>24</td><td>11.5</td><td>12.5</td><td>50</td><td>24.5</td><td>25.5</td></tr> <tr><td></td><td></td><td></td><td>60</td><td>29.5</td><td>30.5</td></tr> </tbody> </table>	Dimension	A	B	Dimension	A	B	10	4.5	5.5	26	12.5	13.5	12	5.5	6.5	30	14.5	15.5	13	6.0	7.0	32	15.5	16.5	15	7.0	8.0	33	16.0	17.0	16	7.5	8.5	34	16.5	17.5	17	8.0	9.0	36	17.5	18.5	18	8.5	9.5	40	19.5	20.5	20	9.5	10.5	45	22.0	23.0	22	10.5	11.5	49	24.0	25.0	24	11.5	12.5	50	24.5	25.5				60	29.5	30.5	<p style="text-align: center;">Recommended metal mask thickness : 0.15mm</p> <p style="text-align: right;">Unit: mm</p> <table border="1"> <thead> <tr> <th>Dimension</th> <th>A</th> <th>B</th> <th>Dimension</th> <th>A</th> <th>B</th> </tr> </thead> <tbody> <tr><td>10</td><td>6.5</td><td>4.5</td><td>26</td><td>14.5</td><td>12.5</td></tr> <tr><td>12</td><td>7.5</td><td>5.5</td><td>30</td><td>16.5</td><td>14.5</td></tr> <tr><td>13</td><td>8.0</td><td>6.0</td><td>32</td><td>17.5</td><td>15.5</td></tr> <tr><td>15</td><td>9.0</td><td>7.0</td><td>33</td><td>18.0</td><td>16.0</td></tr> <tr><td>16</td><td>9.5</td><td>7.5</td><td>34</td><td>18.5</td><td>16.5</td></tr> <tr><td>17</td><td>10.0</td><td>8.0</td><td>36</td><td>19.5</td><td>17.5</td></tr> <tr><td>18</td><td>10.5</td><td>8.5</td><td>40</td><td>21.5</td><td>19.5</td></tr> <tr><td>20</td><td>11.5</td><td>9.5</td><td>45</td><td>24.0</td><td>22.0</td></tr> <tr><td>22</td><td>12.5</td><td>10.5</td><td>49</td><td>26.0</td><td>24.0</td></tr> <tr><td>24</td><td>13.5</td><td>11.5</td><td>50</td><td>26.5</td><td>24.5</td></tr> <tr><td></td><td></td><td></td><td>60</td><td>31.5</td><td>29.5</td></tr> </tbody> </table>	Dimension	A	B	Dimension	A	B	10	6.5	4.5	26	14.5	12.5	12	7.5	5.5	30	16.5	14.5	13	8.0	6.0	32	17.5	15.5	15	9.0	7.0	33	18.0	16.0	16	9.5	7.5	34	18.5	16.5	17	10.0	8.0	36	19.5	17.5	18	10.5	8.5	40	21.5	19.5	20	11.5	9.5	45	24.0	22.0	22	12.5	10.5	49	26.0	24.0	24	13.5	11.5	50	26.5	24.5				60	31.5	29.5																																																																																								
Dimension	A	B	Dimension	A	B																																																																																																																																																																																																																																					
10	4.5	5.5	26	12.5	13.5																																																																																																																																																																																																																																					
12	5.5	6.5	30	14.5	15.5																																																																																																																																																																																																																																					
13	6.0	7.0	32	15.5	16.5																																																																																																																																																																																																																																					
15	7.0	8.0	33	16.0	17.0																																																																																																																																																																																																																																					
16	7.5	8.5	34	16.5	17.5																																																																																																																																																																																																																																					
17	8.0	9.0	36	17.5	18.5																																																																																																																																																																																																																																					
18	8.5	9.5	40	19.5	20.5																																																																																																																																																																																																																																					
20	9.5	10.5	45	22.0	23.0																																																																																																																																																																																																																																					
22	10.5	11.5	49	24.0	25.0																																																																																																																																																																																																																																					
24	11.5	12.5	50	24.5	25.5																																																																																																																																																																																																																																					
			60	29.5	30.5																																																																																																																																																																																																																																					
Dimension	A	B	Dimension	A	B																																																																																																																																																																																																																																					
10	6.5	4.5	26	14.5	12.5																																																																																																																																																																																																																																					
12	7.5	5.5	30	16.5	14.5																																																																																																																																																																																																																																					
13	8.0	6.0	32	17.5	15.5																																																																																																																																																																																																																																					
15	9.0	7.0	33	18.0	16.0																																																																																																																																																																																																																																					
16	9.5	7.5	34	18.5	16.5																																																																																																																																																																																																																																					
17	10.0	8.0	36	19.5	17.5																																																																																																																																																																																																																																					
18	10.5	8.5	40	21.5	19.5																																																																																																																																																																																																																																					
20	11.5	9.5	45	24.0	22.0																																																																																																																																																																																																																																					
22	12.5	10.5	49	26.0	24.0																																																																																																																																																																																																																																					
24	13.5	11.5	50	26.5	24.5																																																																																																																																																																																																																																					
			60	31.5	29.5																																																																																																																																																																																																																																					

◆ Recommended FPC/FFC dimensions and Land/Metal Mask dimensions

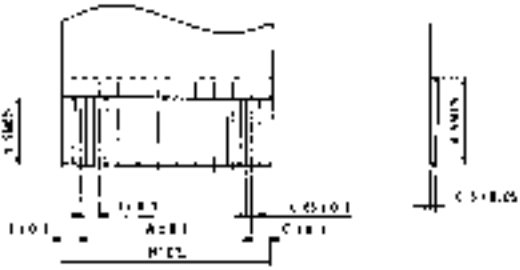
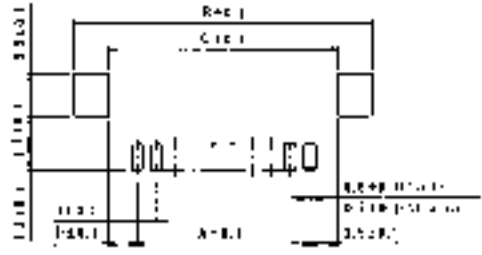
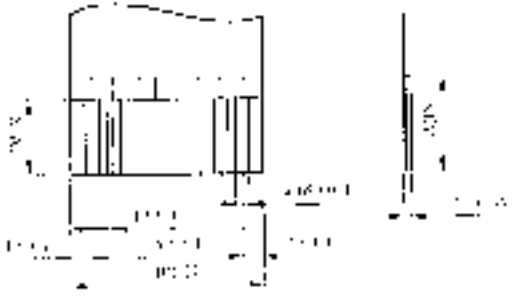
● 1mm Pitch Product

	FPC/FFC dimensions	Land / Metal Mask dimensions																																																																																																																																																																																																																																					
1mm Pitch Bottom Contact Type	 <p>※Set the stiffener thickness to 0.188 (7.5mil) min.</p>	 <p>Recommended metal mask thickness : 0.15mm</p>																																																																																																																																																																																																																																					
	<p style="text-align: right;">Unit: mm</p> <table border="1"> <thead> <tr> <th rowspan="2">Dimension Number of Contacts</th> <th colspan="3">Standard Type</th> <th rowspan="2">Dimension Number of Contacts</th> <th colspan="3">Eccentric Type</th> </tr> <tr> <th>A</th> <th>B</th> <th>C</th> <th>A</th> <th>B</th> <th>C</th> </tr> </thead> <tbody> <tr><td>5</td><td>4</td><td>6</td><td>1</td><td>4</td><td>3</td><td>5.5</td><td>1.5</td></tr> <tr><td>6</td><td>5</td><td>7</td><td>1</td><td>6</td><td>5</td><td>7.5</td><td>1.5</td></tr> <tr><td>7</td><td>6</td><td>8</td><td>1</td><td>8</td><td>7</td><td>9.5</td><td>1.5</td></tr> <tr><td>8</td><td>7</td><td>9</td><td>1</td><td>10</td><td>9</td><td>11.5</td><td>1.5</td></tr> <tr><td>9</td><td>8</td><td>10</td><td>1</td><td>11</td><td>10</td><td>12.5</td><td>1.5</td></tr> <tr><td>11</td><td>10</td><td>12</td><td>1</td><td>14</td><td>13</td><td>15.5</td><td>1.5</td></tr> <tr><td>12</td><td>11</td><td>13</td><td>1</td><td>19</td><td>18</td><td>20.5</td><td>1.5</td></tr> <tr><td>16</td><td>15</td><td>17</td><td>1</td><td>24</td><td>23</td><td>25.5</td><td>1.5</td></tr> <tr><td>17</td><td>16</td><td>18</td><td>1</td><td></td><td></td><td></td><td></td></tr> <tr><td>22</td><td>21</td><td>23</td><td>1</td><td></td><td></td><td></td><td></td></tr> <tr><td>26</td><td>25</td><td>27</td><td>1</td><td></td><td></td><td></td><td></td></tr> </tbody> </table>	Dimension Number of Contacts	Standard Type			Dimension Number of Contacts	Eccentric Type			A	B	C	A	B	C	5	4	6	1	4	3	5.5	1.5	6	5	7	1	6	5	7.5	1.5	7	6	8	1	8	7	9.5	1.5	8	7	9	1	10	9	11.5	1.5	9	8	10	1	11	10	12.5	1.5	11	10	12	1	14	13	15.5	1.5	12	11	13	1	19	18	20.5	1.5	16	15	17	1	24	23	25.5	1.5	17	16	18	1					22	21	23	1					26	25	27	1					<p style="text-align: right;">Unit: mm</p> <table border="1"> <thead> <tr> <th rowspan="2">Dimension Number of Contacts</th> <th colspan="4">Standard Type</th> <th rowspan="2">Dimension Number of Contacts</th> <th colspan="4">Eccentric Type</th> </tr> <tr> <th>A</th> <th>B</th> <th>C</th> <th>D</th> <th>A</th> <th>B</th> <th>C</th> <th>D</th> </tr> </thead> <tbody> <tr><td>5</td><td>4</td><td>10.6</td><td>7</td><td>1.5</td><td>4</td><td>3</td><td>10.1</td><td>6.5</td><td>2</td></tr> <tr><td>6</td><td>5</td><td>11.6</td><td>8</td><td>1.5</td><td>6</td><td>5</td><td>12.1</td><td>8.5</td><td>2</td></tr> <tr><td>7</td><td>6</td><td>12.6</td><td>9</td><td>1.5</td><td>8</td><td>7</td><td>14.1</td><td>10.5</td><td>2</td></tr> <tr><td>8</td><td>7</td><td>13.6</td><td>10</td><td>1.5</td><td>10</td><td>9</td><td>16.1</td><td>12.5</td><td>2</td></tr> <tr><td>9</td><td>8</td><td>14.6</td><td>11</td><td>1.5</td><td>11</td><td>10</td><td>17.1</td><td>13.5</td><td>2</td></tr> <tr><td>11</td><td>10</td><td>16.6</td><td>13</td><td>1.5</td><td>14</td><td>13</td><td>20.1</td><td>16.5</td><td>2</td></tr> <tr><td>12</td><td>11</td><td>17.6</td><td>14</td><td>1.5</td><td>19</td><td>18</td><td>25.1</td><td>21.5</td><td>2</td></tr> <tr><td>16</td><td>15</td><td>21.6</td><td>18</td><td>1.5</td><td>24</td><td>23</td><td>30.1</td><td>26.5</td><td>2</td></tr> <tr><td>17</td><td>16</td><td>22.6</td><td>19</td><td>1.5</td><td></td><td></td><td></td><td></td><td></td></tr> <tr><td>22</td><td>21</td><td>27.6</td><td>24</td><td>1.5</td><td></td><td></td><td></td><td></td><td></td></tr> <tr><td>26</td><td>25</td><td>31.6</td><td>28</td><td>1.5</td><td></td><td></td><td></td><td></td><td></td></tr> </tbody> </table>	Dimension Number of Contacts	Standard Type				Dimension Number of Contacts	Eccentric Type				A	B	C	D	A	B	C	D	5	4	10.6	7	1.5	4	3	10.1	6.5	2	6	5	11.6	8	1.5	6	5	12.1	8.5	2	7	6	12.6	9	1.5	8	7	14.1	10.5	2	8	7	13.6	10	1.5	10	9	16.1	12.5	2	9	8	14.6	11	1.5	11	10	17.1	13.5	2	11	10	16.6	13	1.5	14	13	20.1	16.5	2	12	11	17.6	14	1.5	19	18	25.1	21.5	2	16	15	21.6	18	1.5	24	23	30.1	26.5	2	17	16	22.6	19	1.5						22	21	27.6	24	1.5						26	25	31.6	28	1.5				
Dimension Number of Contacts	Standard Type			Dimension Number of Contacts	Eccentric Type																																																																																																																																																																																																																																		
	A	B	C		A	B	C																																																																																																																																																																																																																																
5	4	6	1	4	3	5.5	1.5																																																																																																																																																																																																																																
6	5	7	1	6	5	7.5	1.5																																																																																																																																																																																																																																
7	6	8	1	8	7	9.5	1.5																																																																																																																																																																																																																																
8	7	9	1	10	9	11.5	1.5																																																																																																																																																																																																																																
9	8	10	1	11	10	12.5	1.5																																																																																																																																																																																																																																
11	10	12	1	14	13	15.5	1.5																																																																																																																																																																																																																																
12	11	13	1	19	18	20.5	1.5																																																																																																																																																																																																																																
16	15	17	1	24	23	25.5	1.5																																																																																																																																																																																																																																
17	16	18	1																																																																																																																																																																																																																																				
22	21	23	1																																																																																																																																																																																																																																				
26	25	27	1																																																																																																																																																																																																																																				
Dimension Number of Contacts	Standard Type				Dimension Number of Contacts	Eccentric Type																																																																																																																																																																																																																																	
	A	B	C	D		A	B	C	D																																																																																																																																																																																																																														
5	4	10.6	7	1.5	4	3	10.1	6.5	2																																																																																																																																																																																																																														
6	5	11.6	8	1.5	6	5	12.1	8.5	2																																																																																																																																																																																																																														
7	6	12.6	9	1.5	8	7	14.1	10.5	2																																																																																																																																																																																																																														
8	7	13.6	10	1.5	10	9	16.1	12.5	2																																																																																																																																																																																																																														
9	8	14.6	11	1.5	11	10	17.1	13.5	2																																																																																																																																																																																																																														
11	10	16.6	13	1.5	14	13	20.1	16.5	2																																																																																																																																																																																																																														
12	11	17.6	14	1.5	19	18	25.1	21.5	2																																																																																																																																																																																																																														
16	15	21.6	18	1.5	24	23	30.1	26.5	2																																																																																																																																																																																																																														
17	16	22.6	19	1.5																																																																																																																																																																																																																																			
22	21	27.6	24	1.5																																																																																																																																																																																																																																			
26	25	31.6	28	1.5																																																																																																																																																																																																																																			
1mm Pitch Vertical Mounting Type	 <p>※Set the stiffener thickness to 0.188 (7.5mil) min.</p>	 <p>Recommended metal mask thickness : 0.15mm</p>																																																																																																																																																																																																																																					
	<p style="text-align: right;">Unit: mm</p> <table border="1"> <thead> <tr> <th>Dimension Number of Contacts</th> <th>A</th> <th>B</th> </tr> </thead> <tbody> <tr><td>6</td><td>5</td><td>7</td></tr> <tr><td>7</td><td>6</td><td>8</td></tr> <tr><td>8</td><td>7</td><td>9</td></tr> <tr><td>16</td><td>15</td><td>17</td></tr> <tr><td>20</td><td>19</td><td>21</td></tr> <tr><td>22</td><td>21</td><td>23</td></tr> <tr><td>24</td><td>23</td><td>25</td></tr> </tbody> </table>	Dimension Number of Contacts	A	B	6	5	7	7	6	8	8	7	9	16	15	17	20	19	21	22	21	23	24	23	25	<p style="text-align: right;">Unit: mm</p> <table border="1"> <thead> <tr> <th>Dimension Number of Contacts</th> <th>A</th> <th>B</th> </tr> </thead> <tbody> <tr><td>6</td><td>8</td><td>5</td></tr> <tr><td>7</td><td>9</td><td>6</td></tr> <tr><td>8</td><td>10</td><td>7</td></tr> <tr><td>16</td><td>18</td><td>15</td></tr> <tr><td>20</td><td>22</td><td>19</td></tr> <tr><td>22</td><td>24</td><td>21</td></tr> <tr><td>24</td><td>26</td><td>23</td></tr> </tbody> </table>	Dimension Number of Contacts	A	B	6	8	5	7	9	6	8	10	7	16	18	15	20	22	19	22	24	21	24	26	23																																																																																																																																																																																					
Dimension Number of Contacts	A	B																																																																																																																																																																																																																																					
6	5	7																																																																																																																																																																																																																																					
7	6	8																																																																																																																																																																																																																																					
8	7	9																																																																																																																																																																																																																																					
16	15	17																																																																																																																																																																																																																																					
20	19	21																																																																																																																																																																																																																																					
22	21	23																																																																																																																																																																																																																																					
24	23	25																																																																																																																																																																																																																																					
Dimension Number of Contacts	A	B																																																																																																																																																																																																																																					
6	8	5																																																																																																																																																																																																																																					
7	9	6																																																																																																																																																																																																																																					
8	10	7																																																																																																																																																																																																																																					
16	18	15																																																																																																																																																																																																																																					
20	22	19																																																																																																																																																																																																																																					
22	24	21																																																																																																																																																																																																																																					
24	26	23																																																																																																																																																																																																																																					

◆ Packaging Specification

Embossed Carrier Tape Dimensions

Horizontal Type (Common to Bottom/Top Contact, 0.5mm/1mm Pitch)

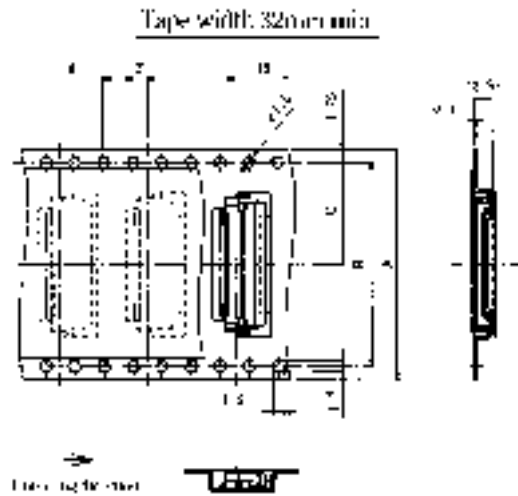
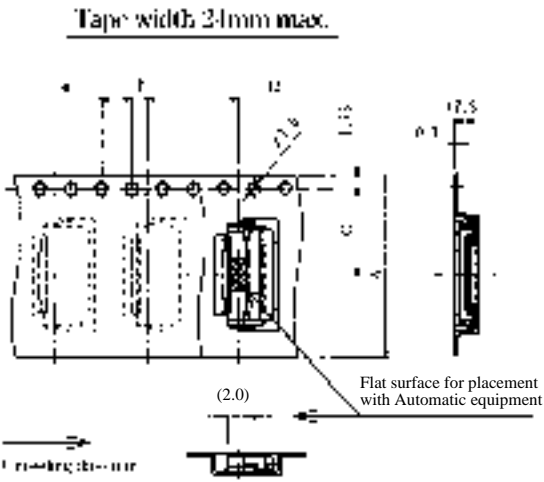

● 0.5mm Pitch Bottom/Top Contact Type

Unit:mm

Dimension Number of Contacts	A	B	C	D	E
6	16	—	7.5	17.4	21.4
8	16	—	7.5	17.4	21.4
10	16	—	7.5	17.4	21.4
11	16	—	7.5	17.4	21.4
12	24	—	11.5	25.4	29.4
13	24	—	11.5	25.4	29.4
14	24	—	11.5	25.4	29.4
15	24	—	11.5	25.4	29.4
16	24	—	11.5	25.4	29.4
17	24	—	11.5	25.4	29.4
18	24	—	11.5	25.4	29.4
19	24	—	11.5	25.4	29.4
20	24	—	11.5	25.4	29.4
22	24	—	11.5	25.4	29.4
24	24	—	11.5	25.4	29.4

Dimension Number of Contacts	A	B	C	D	E
25	24	—	11.5	25.4	29.4
26	24	—	11.5	25.4	29.4
28	32	28.4	14.2	33.4	37.4
29	32	28.4	14.2	33.4	37.4
30	32	28.4	14.2	33.4	37.4
32	32	28.4	14.2	33.4	37.4
33	32	28.4	14.2	33.4	37.4
34	32	28.4	14.2	33.4	37.4
35	44	40.4	20.2	45.4	49.4
36	44	40.4	20.2	45.4	49.4
40	44	40.4	20.2	45.4	49.4
42	44	40.4	20.2	45.4	49.4
45	44	40.4	20.2	45.4	49.4
50	44	40.4	20.2	45.4	49.4
53	44	40.4	20.2	45.4	49.4

Note: 2,000 pieces per reel.

● 1mm Pitch Bottom Contact Type

Unit:mm

	Dimension Number of Contacts	A	B	C	D	E
	Standard Type	5	16	—	7.5	17.4
6		24	—	11.5	25.4	29.4
7		24	—	11.5	25.4	29.4
8		24	—	11.5	25.4	29.4
9		24	—	11.5	25.4	29.4
11		24	—	11.5	25.4	29.4
12		24	—	11.5	25.4	29.4
16		32	28.4	14.2	33.4	37.4
17		44	40.4	20.2	45.4	49.4
22		44	40.4	20.2	45.4	49.4
26		44	40.4	20.2	45.4	49.4

	Dimension Number of Contacts	A	B	C	D	E
	Eccentric Type	4	16	—	7.5	17.4
6		24	—	11.5	25.4	29.4
8		24	—	11.5	25.4	29.4
10		24	—	11.5	25.4	29.4
11		24	—	11.5	25.4	29.4
14		32	28.4	14.2	33.4	37.4
19		44	40.4	20.2	45.4	49.4
24		44	40.4	20.2	45.4	49.4

Note: 2,000 pieces per reel.

Vertical Mounting Type (Common to 0.5mm/1mm Pitch)

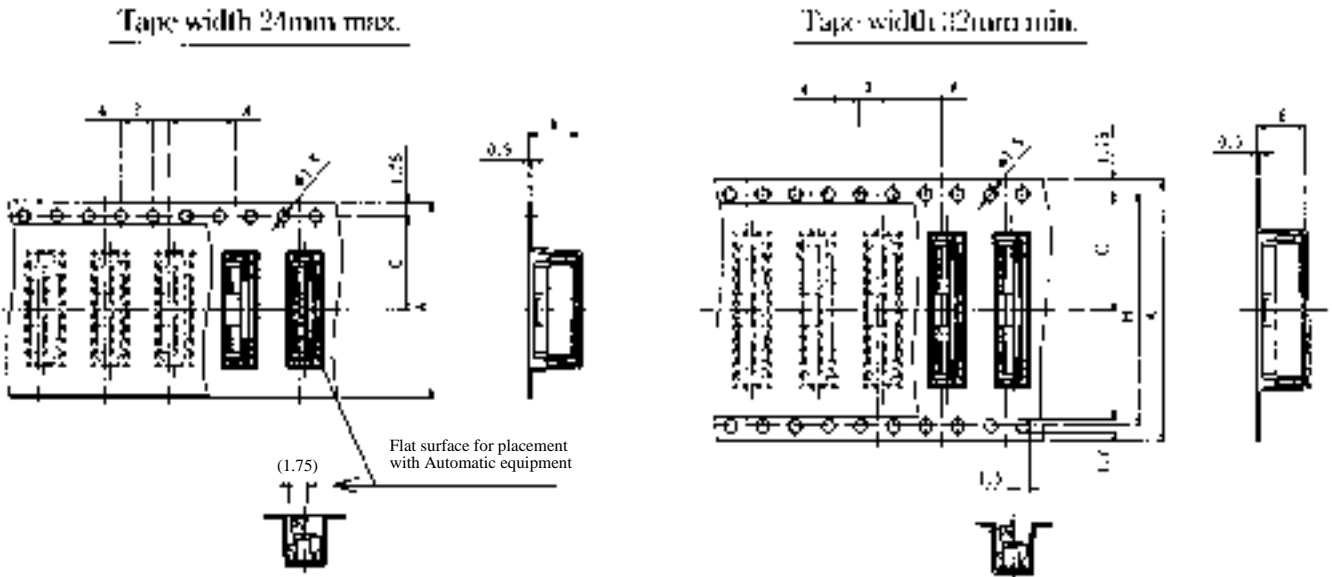

●0.5mm Pitch Vertical mounting Type

Unit:mm

Dimension Number of Contacts	A	B	C	D	E
10	16	—	7.5	17.4	21.4
12	16	—	7.5	17.4	21.4
13	24	—	11.5	25.4	29.4
15	24	—	11.5	25.4	29.4
16	24	—	11.5	25.4	29.4
17	24	—	11.5	25.4	29.4
18	24	—	11.5	25.4	29.4
20	24	—	11.5	25.4	29.4
22	24	—	11.5	25.4	29.4
24	24	—	11.5	25.4	29.4

Dimension Number of Contacts	A	B	C	D	E
26	24	—	11.5	25.4	29.4
30	32	28.4	14.2	33.4	37.4
32	32	28.4	14.2	33.4	37.4
33	32	28.4	14.2	33.4	37.4
34	44	40.4	20.2	45.4	49.4
36	44	40.4	20.2	45.4	49.4
40	44	40.4	20.2	45.4	49.4
45	44	40.4	20.2	45.4	49.4
49	44	40.4	20.2	45.4	49.4
50	44	40.4	20.2	45.4	49.4
60	56	52.4	26.2	57.4	61.4

Note: 1,000 pieces per reel.

●1mm Pitch Vertical mounting Type

Unit:mm

Dimension Number of Contacts	A	B	C	D	E
6	24	—	11.5	25.4	29.4
7	24	—	11.5	25.4	29.4
8	24	—	11.5	25.4	29.4
16	32	28.4	14.2	33.4	37.4
20	44	40.4	20.2	45.4	49.4
22	44	40.4	20.2	45.4	49.4
24	44	40.4	20.2	45.4	49.4

Note: 1,000 pieces per reel.

PH12 Series 0.5mm and 1mm Pitch Connectors For FP-C/FP-C

Reel Dimensions (Common to All Types)

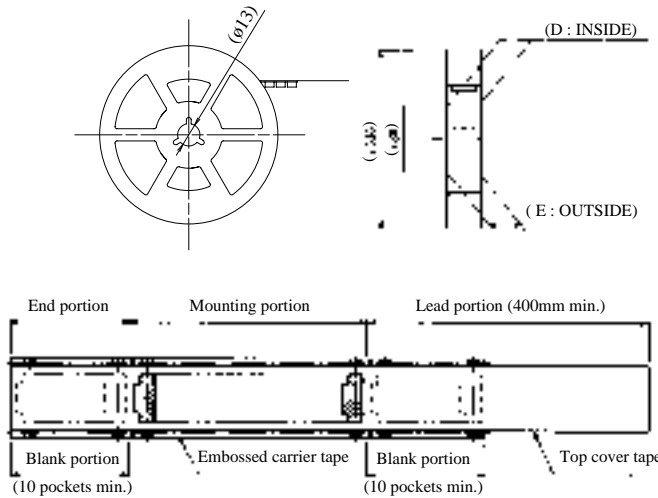

Recommended Temperature Profile

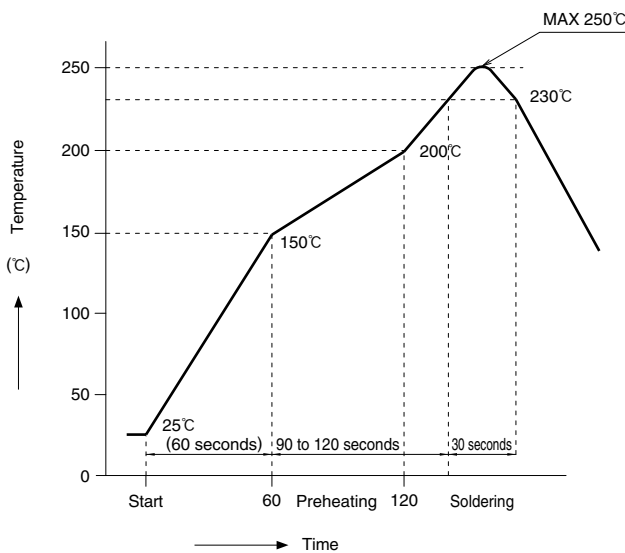

HRS test conditions

Solder method	:Reflow, IR/hot air (Nihon Den-netzu Co., Ltd.'s Part Number: SENSBY NR- II)
Environment:	:Room air
Solder composition	:Paste, 96.5%Sn/3%Ag/0.5%Cu (Senju Metal Industry, Co., Ltd.'s Part Number: M705-221CM5-42-10.5)
Test board	:Glass epoxy 40mm×80mm×1.6mm thick
Land dimensions	:Top and bottom contact type 0.3mm×1.3mm Vertical mounting type 0.6mm×1.5mm
Metal mask	:Top and bottom contact type 0.25mm×1.3mm×0.15mm thick Vertical mounting type 0.5mm×1.5mm×0.15mm thick

This temperature profile is based on the above conditions. In individual applications the actual temperature may vary, depending on solder paste type, volume/thickness and board size/thickness. Consult your solder paste and equipment manufacturer for specific recommendations.

◆FH12 Series FPC/FFC Construction (Recommended Specifications)

1. FFC

FFC : Flexible Flat Cable

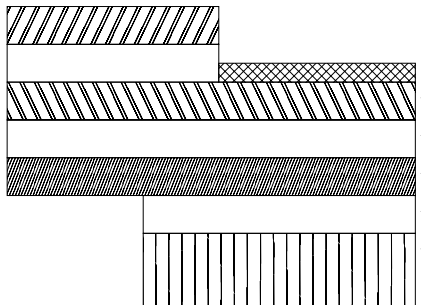

Material Name	Material	Thickness (μm)
(Nickel under plated / Gold plated), soft copper film		35
Adhesive	Polyester type	30
Polyester		12
Adhesive	Polyester type	30
Stiffener	Polyester type	188 (Note)
Total		295

*Real tolerance of thickness dimension is on the order of $\pm 20 \mu\text{m}$ (275 to 315 μm)

Note: Use of a thicker FFC results in a stiffer lock action and the lock is more easily released.

A factor that contributes to thicker FFC is the use of 250 μm stiffener which is thicker than the standard (188 μm) product. This results in a total thickness of 357 μm .

When using FFC, control of FFC thickness becomes easy if you indicate to us the thickness of the stiffener.

2. FPC

FPC : Flexible Printed Circuit

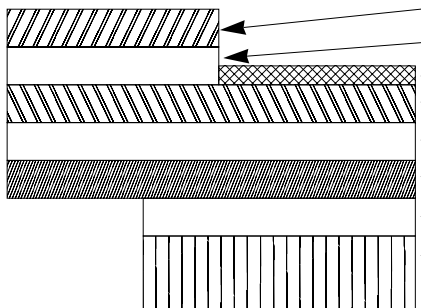

Material Name	Material	Thickness (μm)
Covering layer film	Polyimide 1 mil	25
Cover adhesive		25
Surface treatment	Nickel under plated 1to 5 μm / Gold plated 0.2 μm	3
Copper foil	Cu 1oz	35
Base adhesive		25
Base film	Polyimide 1 mil	25
Reinforcement material adhesive	Heat-hardened adhesive	30
Stiffener	Polyimide 7 mil	175
Total		293

3. Precautions

1. This specification is a recommendation for the construction of the FH12 Series FPC and FFC ($t=0.3 \pm 0.05$).
2. For details about the construction, please contact the FPC/FFC manufacturers.