

## 1. DESCRIPTION

The ST8016 is a 160-output segment/common driver IC suitable for driving large/medium scale dot matrix LCD panels, and is used in personal computers/work stations. Through the use of SST (Super Slim TCP) technology, it is ideal for substantially decreasing the size of the frame section of the LCD module. The ST8016 is good both as a segment driver and a common driver, and it can create a low power consuming, high-resolution LCD.

## 2. FEATURES

- Number of LCD drive outputs: 160
- Supply voltage for LCD drive: +15.0 to +40.0 V
- Supply voltage for the logic system: +2.5 to +5.5 V
- Low power consumption
- Low output impedance

Package: 186-pin TCP (Tape Carrier Package)

(Segment mode)

- Shift clock frequency
  - 20 MHz (MAX.):  $V_{DD} = +5.0 \pm 0.5$  V
  - 15 MHz (MAX.):  $V_{DD} = +3.0$  to + 4.5 V
  - 12 MHz (MAX.):  $V_{DD} = +2.5$  to + 3.0 V
- Adopts a data bus system
- 4-bit/8-bit parallel input modes are selectable with a mode (MD) pin
- Automatic transfer function of an enable signal
- Automatic counting function which, in the chip selection mode, causes the internal clock to be stopped by automatically counting 160 bits of input data

- Line latch circuits are reset when  $\overline{\text{DISPOFF}}$  active

(Common mode)

- Shift clock frequency: 4 MHz (MAX.)
- Built-in 160-bit bi-directional shift register (divisible into 80 bits x 2)
- Available in a single mode (160-bit shift register) or in a dual mode (80-bit shift register x 2)
  - $Y_1 \rightarrow Y_{160}$  Single mode
  - $Y_{160} \rightarrow Y_1$  Single mode
  - $Y_1 \rightarrow Y_{80}, Y_{81} \rightarrow Y_{160}$  Dual mode
  - $Y_{160} \rightarrow Y_{81}, Y_{80} \rightarrow Y_1$  Dual mode

The above 4 shift directions are pin-selectable

- Shift register circuits are reset when  $\overline{\text{DISPOFF}}$  active

## 3. PIN CONNECTIONS

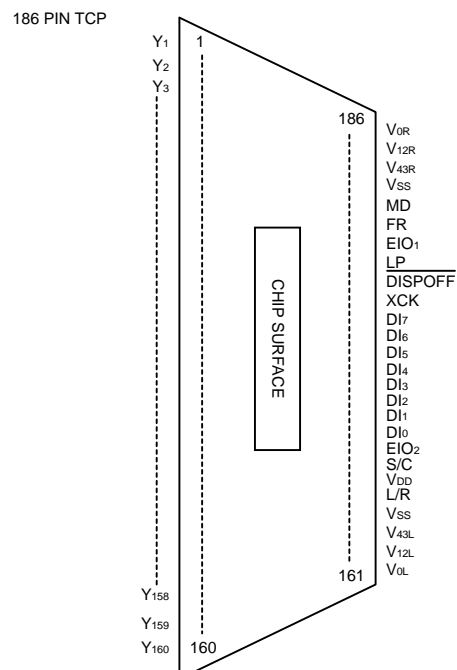

### 4. PIN DESCRIPTION (TCP TYPE)

PIN NO.	SYMBOL	I/O	DESCRIPTION
1 ~ 160	Y <sub>1</sub> -Y <sub>160</sub>	O	LCD drive output
161,186	V <sub>0L</sub> , V <sub>0R</sub>	P	Power supply for LCD drive
162,185	V <sub>12L</sub> , V <sub>12R</sub>	P	Power supply for LCD drive
163,184	V <sub>43L</sub> , V <sub>43R</sub>	P	Power supply for LCD drive
165	L/R	I	Display data shift direction selection
166	V <sub>DD</sub>	P	Power supply for logic system (+2.5 to +5.5 V)
167	S/C	I	Segment mode/common mode selection
168,180	EIO <sub>2</sub> , EIO <sub>1</sub>	I/O	Input/output for chip selection at segment mode Shift data input/output for shift register at common mode
169 ~ 175	DI <sub>0</sub> -DI <sub>6</sub>	I	Display data input at segment mode
176	DI <sub>7</sub>	I	Display data input at segment mode/Dual mode data input at common mode
177	XCK	I	Clock input for taking display data at segment mode
178	/DISPOFF	I	Control input for output of non-select level
179	LP	I	Latch pulse input for display data at segment mode/ Shift clock input for shift register at common mode
181	FR	I	AC-converting signal input for LCD drive waveform
182	MD	I	Mode selection input
164,183	V <sub>SS</sub>	P	Ground (0 V)

P: power pin

### 5. BLOCK DIAGRAM

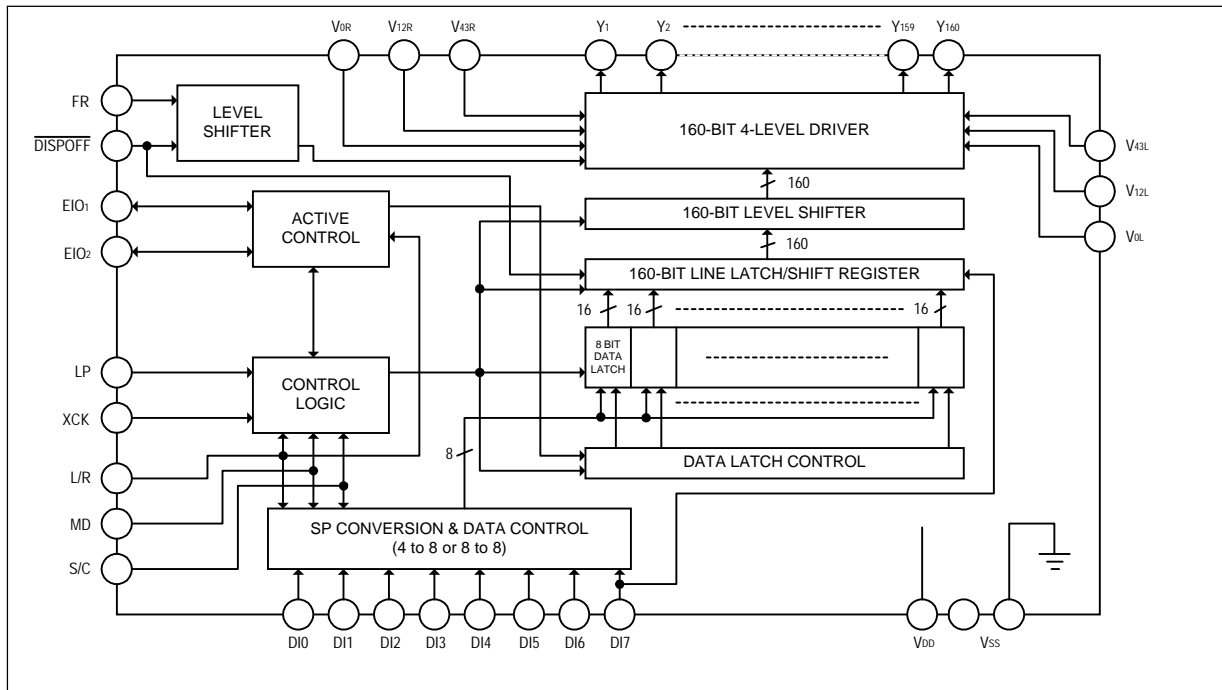

## 6. FUNCTIONAL OPERATIONS OF EACH BLOCK

BLOCK	FUNCTION
Active Control	In case of segment mode, controls the selection or non-selection of the chip. Following an LP signal input, and after the chip selection signal is input, a selection signal is generated internally until 160 bits of data have been read in. Once data input has been completed, a selection signal for cascade connection is output, and the chip is non-selected. In case of common mode, controls the input/output data of bi-directional pins.
SP Conversion & Data Control	In case of segment mode, keeps input data which are 2 clocks of XCK at 4-bit parallel input mode in latch circuit, or keeps input data which are 1 clock of XCK at 8-bit parallel input mode in latch circuit; after that they are put on the internal data bus 8 bits at a time.
Data Latch Control	In case of segment mode, selects the state of the data latch which reads in the data bus signals. The shift direction is controlled by the control logic. For every 16 bits of data read in, the selection signal shifts one bit based on the state of the control circuit.
Data Latch	In case of segment mode, latches the data on the data bus. The latch state of each LCD drive output pin is controlled by the control logic and the data latch control; 160 bits of data are read in 20 sets of 8 bits.
Line Latch/ Shift Register	In case of segment mode, all 160 bits which have been read into the data latch are simultaneously latched at the falling edge of the LP signal, and are output to the level shifter block. In case of common mode, shifts data from the data input pin at the falling edge of the LP signal.
Level Shifter	The logic voltage signal is level-shifted to the LCD drive voltage level, and is output to the driver block.
4-Level Driver	Drives the LCD drive output pins from the line latch/shift register data, and selects one of 4 levels ( $V_0$ , $V_{12}$ , $V_{43}$ or $V_{SS}$ ) based on the S/C, FR and /DISPOFF signals.
Control Logic	Controls the operation of each block. In case of segment mode, when an LP signal has been input, all blocks are reset and the control logic waits for the selection signal output from the active control block. Once the selection signal has been output, operation of the data latch and data transmission is controlled, 160 bits of data are read in, and the chip is non-selected. In case of common mode, controls the direction of data shift.

### INPUT/OUTPUT CIRCUITS

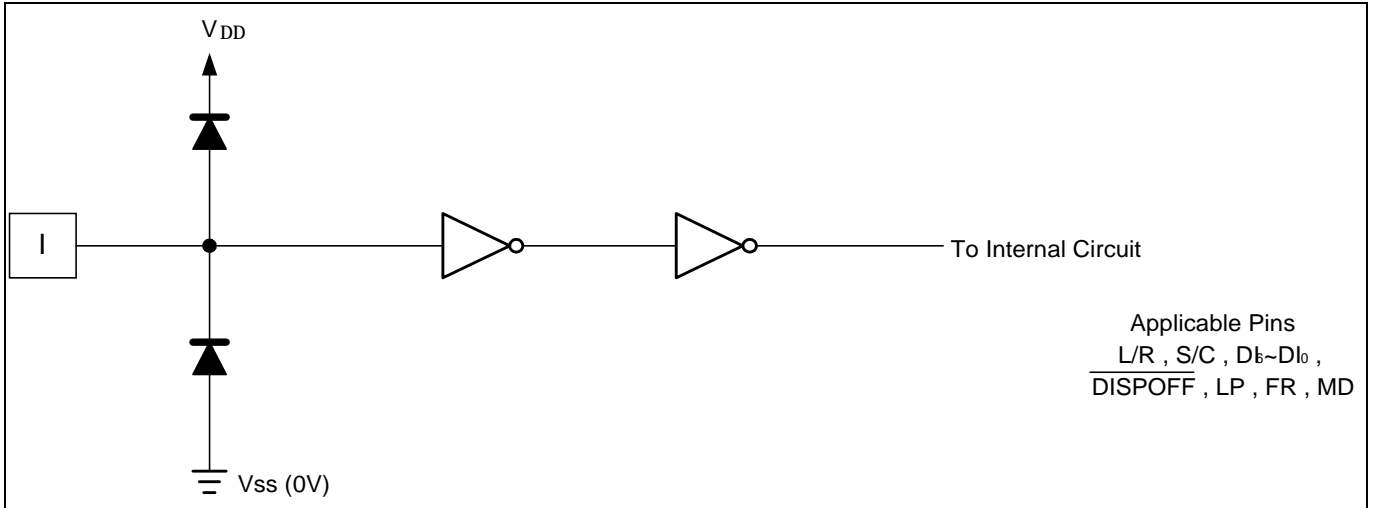

Fig. 1 Input Circuit (1)

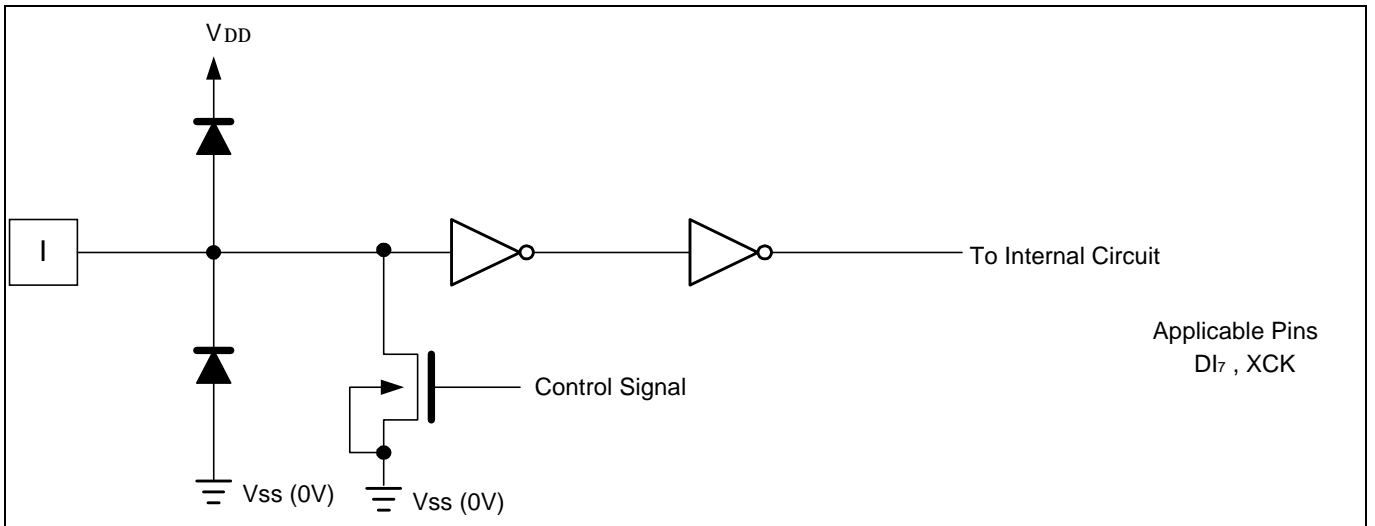

Fig. 2 Input Circuit (2)

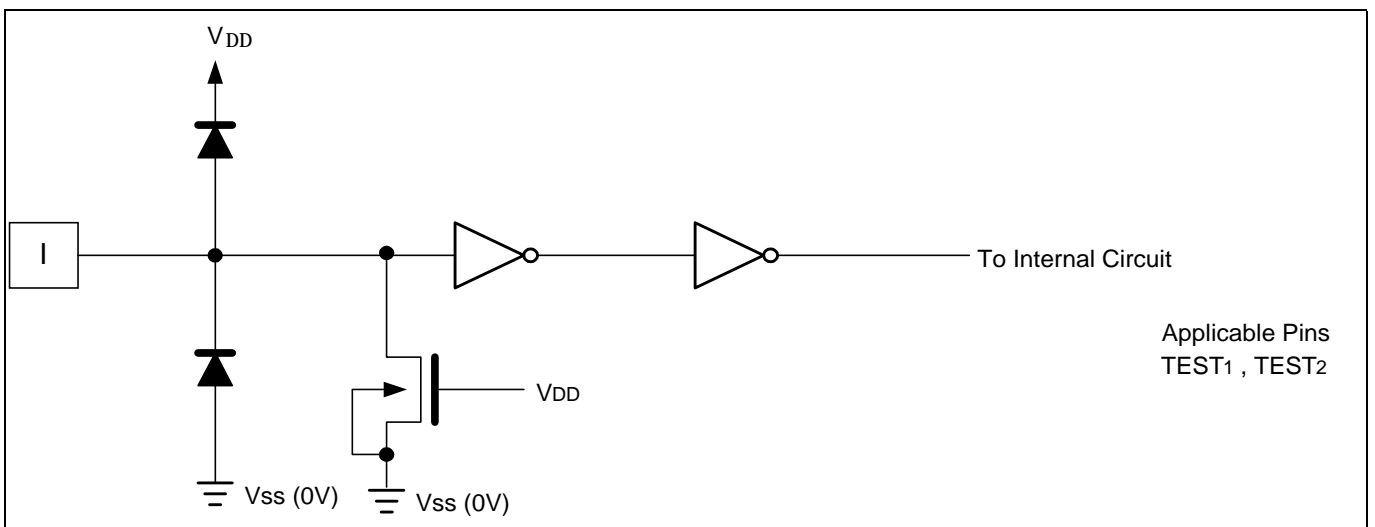

Fig. 3 Input Circuit (3)

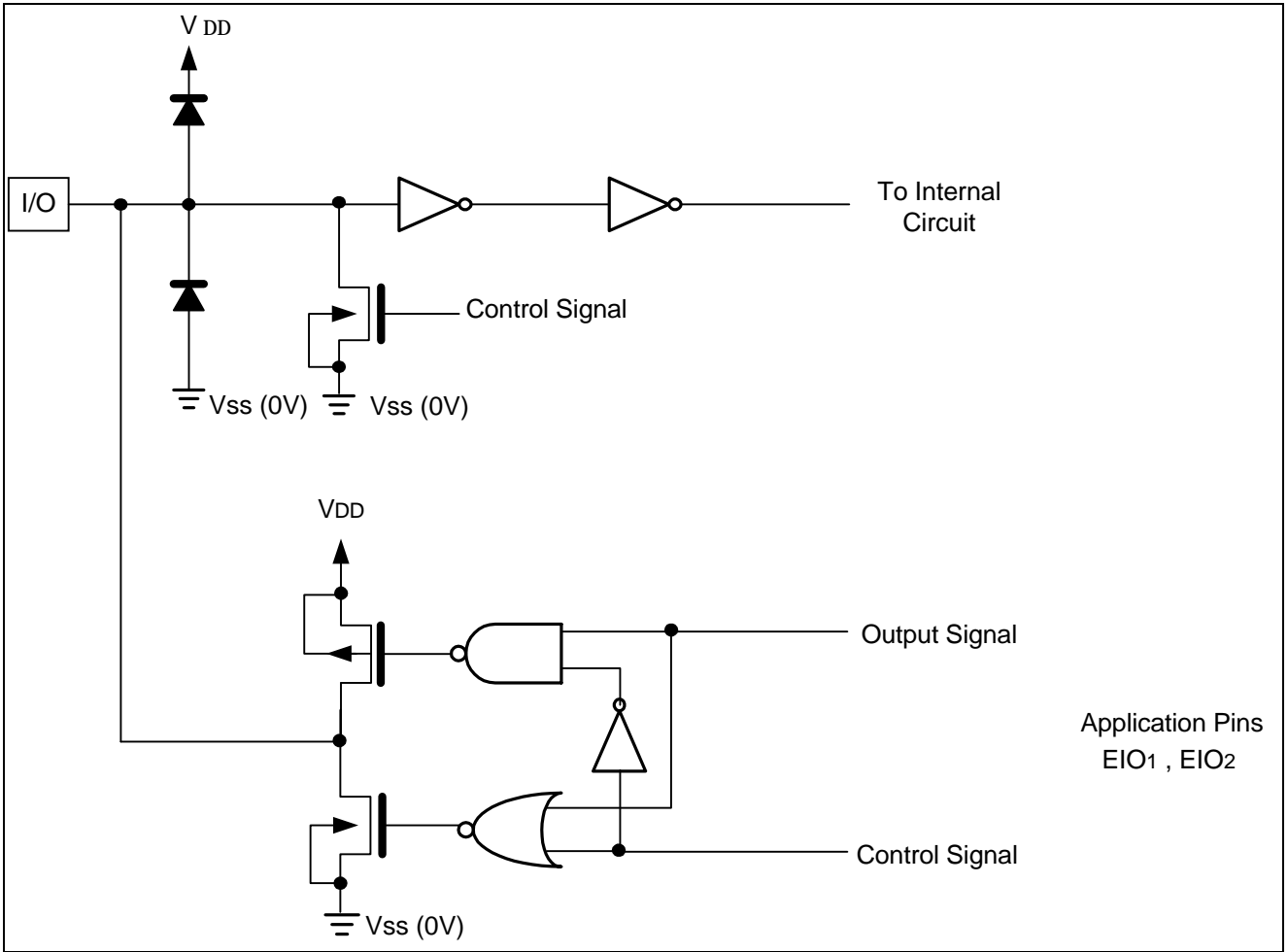

Fig. 4 Input/Output Circuit

Application Pins  
EIO1 , EIO2

Application Pins  
Y1~Y160

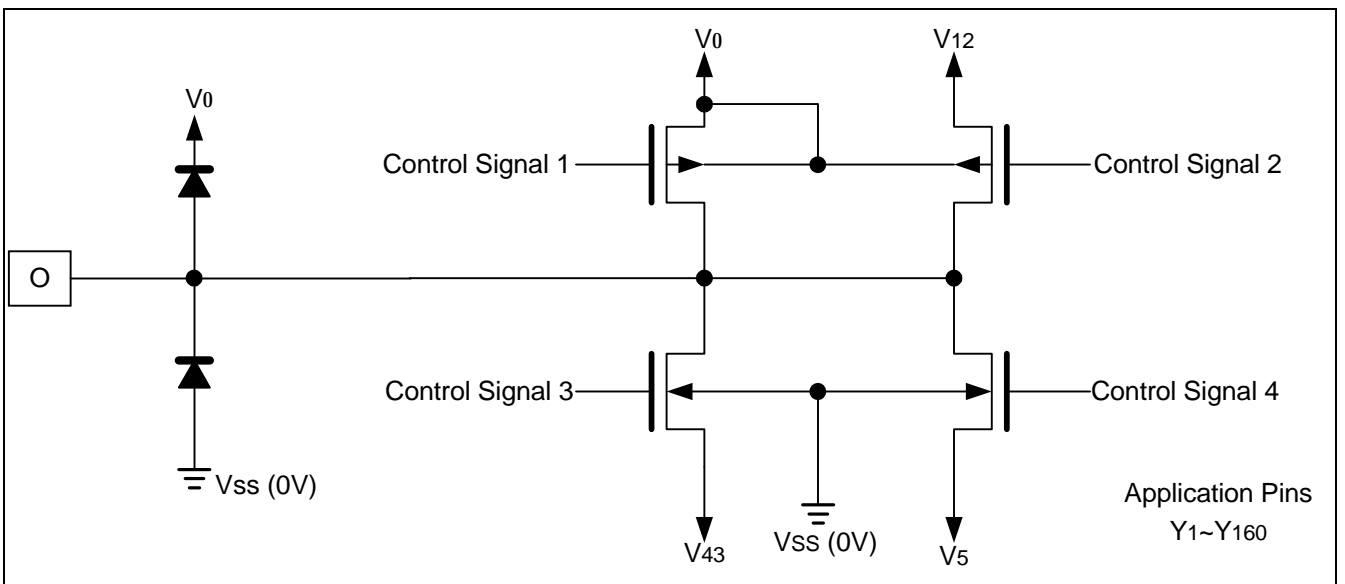

Fig. 5 LCD Drive Output Circuit

## 7. FUNCTIONAL DESCRIPTION

### 7.1 Pin Functions

(Segment mode)

SYMBOL	FUNCTION
V <sub>DD</sub>	Logic system power supply pin, connected to +2.5 to +5.5 V.
V <sub>SS</sub>	Ground pin, connected to 0 V.
V <sub>0L</sub> , V <sub>0R</sub> V <sub>12L</sub> , V <sub>12R</sub> V <sub>43L</sub> , V <sub>43R</sub>	Bias power supply pins for LCD drive voltage <ul style="list-style-type: none"> <li>• Normally use the bias voltages set by a resistor divider</li> <li>• Ensure that voltages are set such that <math>V_{SS} &lt; V_{43} &lt; V_{12} &lt; V_0</math>.</li> <li>• V<sub>iL</sub> and V<sub>iR</sub> (i = 0, 12, 43) must connect to an external power supply, and supply regular voltage which is assigned by specification for each power pin</li> </ul>
DI7-DI0	Input pins for display data <ul style="list-style-type: none"> <li>• In 4-bit parallel input mode, input data into the 4 pins, DI3-DI0. Connect DI7-DI4 to V<sub>SS</sub> or V<sub>DD</sub>.</li> <li>• In 8-bit parallel input mode, input data into the 8 pins, DI7-DI0.</li> <li>• Refer to "RELATIONSHIP BETWEEN THE DISPLAY DATA AND LCD DRIVE OUTPUT PINS" in Functional Operations.</li> </ul>
XCK	Clock input pin for taking display data <ul style="list-style-type: none"> <li>* Data is read at the falling edge of the clock pulse.</li> </ul>
LP	Latch pulse input pin for display data <ul style="list-style-type: none"> <li>• Data is latched at the falling edge of the clock pulse.</li> </ul>
L/R	Input pin for selecting the reading direction of display data <ul style="list-style-type: none"> <li>• When set to V<sub>SS</sub> level "L", data is read sequentially from Y<sub>160</sub> to Y<sub>1</sub>.</li> <li>• When set to V<sub>DD</sub> level "H", data is read sequentially from Y<sub>1</sub> to Y<sub>160</sub>.</li> <li>• Refer to "RELATIONSHIP BETWEEN THE DISPLAY DATA AND LCD DRIVE OUTPUT PINS" in Functional Operations.</li> </ul>
/DISPOFF	Control input pin for output of non-select level <ul style="list-style-type: none"> <li>• The input signal is level-shifted from logic voltage level to LCD drive voltage level, and controls the LCD drive circuit.</li> <li>• When set to V<sub>SS</sub> level "L", the LCD drive output pins (Y<sub>1</sub>-Y<sub>160</sub>) are set to level V<sub>SS</sub>.</li> <li>• When set to "L", the contents of the line latch are reset, but the display data are read in the data latch regardless of the condition of DISPOFF. When the DISPOFF function is canceled, the driver outputs non-select level (V<sub>12</sub> or V<sub>43</sub>), then outputs the contents of the data latch at the next falling edge of the LP. At that time, if DISPOFF removal time does not correspond to what is shown in AC characteristics, it cannot output the reading data correctly.</li> <li>• Table of truth-values is shown in "TRUTH TABLE" in Functional Operations.</li> </ul>
FR	AC signal input pin for LCD drive waveform <ul style="list-style-type: none"> <li>• The input signal is level-shifted from logic voltage level to LCD drive voltage level, and controls the LCD drive circuit.</li> <li>• Normally it inputs a frame inversion signal.</li> <li>• The LCD drive output pins' output voltage levels can be set using the line latch output signal and the FR signal.</li> <li>• Table of truth-values is shown in "TRUTH TABLE" in Functional Operations.</li> </ul>
MD	Mode selection pin <ul style="list-style-type: none"> <li>• When set to V<sub>SS</sub> level "L", 4-bit parallel input mode is set.</li> <li>• When set to V<sub>DD</sub> level "H", 8-bit parallel input mode is set.</li> <li>• Refer to "RELATIONSHIP BETWEEN THE DISPLAY DATA AND LCD DRIVE OUTPUT PINS" in Functional Operations.</li> </ul>
S/C	Segment mode/common mode selection pin <ul style="list-style-type: none"> <li>• When set to V<sub>DD</sub> level "H", segment mode is set.</li> </ul>
EIO <sub>1</sub> , EIO <sub>2</sub>	Input/output pins for chip selection <ul style="list-style-type: none"> <li>• When L/R input is at V<sub>SS</sub> level "L", EIO<sub>1</sub> is set for output, and EIO<sub>2</sub> is set for input.</li> <li>• When L/R input is at V<sub>DD</sub> level "H", EIO<sub>1</sub> is set for input, and EIO<sub>2</sub> is set for output.</li> <li>• During output, set to "H" while LP • XCK is "H" and after 160 bits of data have been read, set to "L" for one cycle (from falling edge to failing edge of XCK), after which it returns to "H".</li> <li>• During input, the chip is selected while EI is set to "L" after the LP signal is input. The chip is non-selected after 160 bits of data have been read.</li> </ul>
OPTION_VDD	Option selection pin <ul style="list-style-type: none"> <li>• For COG layout to reduce interface pins.</li> <li>• Normally let it open</li> </ul>

Y <sub>1</sub> - Y <sub>160</sub>	<p>LCD drive output pins</p> <ul style="list-style-type: none"> <li>• Corresponding directly to each bit of the data latch, one level (V<sub>0</sub>, V<sub>12</sub> or V<sub>43</sub>) is selected and output.</li> <li>• Table of truth values is shown in "TRUTH TABLE" in Functional Operations.</li> </ul>
-----------------------------------	---

(Common mode)

SYMBOL	FUNCTION
V <sub>DD</sub>	Logic system power supply pin, connected to +2.5 to +5.5 V.
V <sub>SS</sub>	Ground pin, connected to 0 V.
V <sub>0L</sub> , V <sub>0R</sub> V <sub>12L</sub> , V <sub>12R</sub> V <sub>43L</sub> , V <sub>43R</sub>	<p>Bias power supply pins for LCD drive voltage</p> <ul style="list-style-type: none"> <li>• Normally use the bias voltages set by a resistor divider.</li> <li>• Ensure that voltages are set such that V<sub>SS</sub> &lt; V<sub>43</sub> &lt; V<sub>12</sub> &lt; V<sub>0</sub>.</li> <li>• V<sub>iL</sub> and V<sub>iR</sub> (i = 0, 12, 43) must connect to an external power supply, and supply regular voltage that is assigned by specification for each power pin.</li> </ul>
EIO <sub>1</sub>	<p>Shift data input/output pin for bi-directional shift register</p> <ul style="list-style-type: none"> <li>• Output pin when L/R is at V<sub>SS</sub> level "L", input pin when L/R is at V<sub>DD</sub> level "H".</li> <li>• When L/R = H, EIO<sub>1</sub> is used as input pin, it will be pulled down.</li> <li>• When L/R = L, EIO<sub>1</sub> is used as output pin, it won't be pulled down.</li> <li>• Refer to "RELATIONSHIP BETWEEN THE DISPLAY DATA AND LCD DRIVE OUTPUT PINS" in Functional Operations.</li> </ul>
EIO <sub>2</sub>	<p>Shift data input/output pin for bi-directional shift register</p> <ul style="list-style-type: none"> <li>• Input pin when L/R is at V<sub>SS</sub> level "L", output pin when L/R is at V<sub>DD</sub> level "H".</li> <li>• When L/R = L, EIO<sub>2</sub> is used as input pin, it will be pulled down.</li> <li>• When L/R = H, EIO<sub>2</sub> is used as output pin, it won't be pulled down.</li> <li>• Refer to "RELATIONSHIP BETWEEN THE DISPLAY DATA AND LCD DRIVE OUTPUT PINS" in Functional Operations.</li> </ul>
LP	<p>Shift clock pulse input pin for bi-directional shift register</p> <ul style="list-style-type: none"> <li>• * Data is shifted at the falling edge of the clock pulse.</li> </ul>
L/R	<p>Input pin for selecting the shift direction of bi-directional shift register</p> <ul style="list-style-type: none"> <li>• Data is shifted from Y<sub>160</sub> to Y<sub>1</sub> when set to V<sub>SS</sub> level "L", and data is shifted from Y<sub>1</sub> to Y<sub>160</sub> when set to V<sub>DD</sub> level "H".</li> <li>• Refer to "RELATIONSHIP BETWEEN THE DISPLAY DATA AND LCD DRIVE OUTPUT PINS" in Functional Operations.</li> </ul>
/DISPOFF	<p>Control input pin for output of non-select level</p> <ul style="list-style-type: none"> <li>• The input signal is level-shifted from logic voltage level to LCD drive voltage level, and controls the LCD drive circuit.</li> <li>• When set to V<sub>SS</sub> level "L", the LCD drive output pins (Y<sub>1</sub>-Y<sub>160</sub>) are set to level V<sub>SS</sub>.</li> <li>• When set to "L", the contents of the shift register are reset to not reading data. When the /DISPOFF function is canceled, the driver outputs non-select level (V<sub>12</sub> or V<sub>43</sub>), and the shift data is read at the next falling edge of the LP. At that time, if /DISPOFF removal time does not correspond to what is shown in AC characteristics, the shift data is not read correctly.</li> <li>• Table of truth-values is shown in "TRUTH TABLE" in Functional Operations.</li> </ul>
FR	<p>AC signal input pin for LCD drive waveform</p> <ul style="list-style-type: none"> <li>• The input signal is level-shifted from logic voltage level to LCD drive voltage level, and controls the LCD drive circuit.</li> <li>• Normally it inputs a frame inversion signal.</li> <li>• The LCD drive output pins' output voltage levels can be set using the shift register output signal and the FR signal.</li> <li>• Table of truth-values is shown in "TRUTH TABLE" in Functional Operations.</li> </ul>
MD	<p>Mode selection pin</p> <ul style="list-style-type: none"> <li>• When set to V<sub>SS</sub> level "L", single mode operation is selected; when set to V<sub>DD</sub> level "H" dual mode operation is selected.</li> <li>• Refer to "RELATIONSHIP BETWEEN THE DISPLAY DATA AND LCD DRIVE OUTPUT PINS" in Functional Operations.</li> </ul>
DI7	<p>Dual mode data input pin</p> <ul style="list-style-type: none"> <li>• According to the data shift direction of the data shift register, data can be input starting from the 81st bit.</li> <li>• When the chip is used in dual mode, DI7 will be pulled down.</li> <li>• When the chip is used in single mode, DI7 won't be pulled down.</li> <li>• Refer to "RELATIONSHIP BETWEEN THE DISPLAY DATA AND LCD DRIVE OUTPUT PINS" in Functional Operations.</li> <li>•</li> </ul>

S/C	Segment mode/common mode selection pin • When set to $V_{SS}$ level "L", common mode is set.
DI6-DI0	Not used • Connect DI6-DI0 to $V_{SS}$ or $V_{DD}$ , avoiding floating.
XCK	Not used • XCK is pulled down in common mode, so connect to $V_{SS}$ or open.
OPTION_VDD	Option selection pin • For COG layout to reduce interface pin.
$Y_1 - Y_{160}$	LCD drive output pins • Corresponding directly to each bit of the shift register, one level ( $V_0$ , $V_{12}$ , $V_{43}$ , or $V_{SS}$ ) is selected and output. • Table of truth-values is shown in "TRUTH TABLE" in Functional Operations.

## 7.2 Functional Operations

### 7.2.1 TRUTH TABLE

(Segment Mode)

FR	LATCH DATA	/DISPOFF	LCD DRIVE OUTPUT VOLTAGE LEVEL (Y1-Y160)
L	L	H	$V_{43}$
L	H	H	$V_{SS}$
H	L	H	$V_{12}$
H	H	H	$V_0$
X	X	L	$V_{SS}$

(Common Mode)

FR	LATCH DATA	/DISPOFF	LCD DRIVE OUTPUT VOLTAGE LEVEL (Y1-Y160)
L	L	H	$V_{43}$
L	H	H	$V_0$
H	L	H	$V_{12}$
H	H	H	$V_{SS}$
X	X	L	$V_{SS}$

NOTES:

- $V_{SS} < V_{43} < V_{12} < V_0$
- L :  $V_{SS}$  (0 V), H :  $V_{DD}$  (+2.5 to +5.5 V), X : Don't care
- "Don't care" should be fixed to "H" or "L", avoiding floating.

There are two kinds of power supply (logic level voltage and LCD drive voltage) for the LCD driver.

Supply regular voltage that is assigned by specification for each power pin.



7.2.2 RELATIONSHIP BETWEEN THE DISPLAY DATA AND LCD DRIVE OUTPUT PINS

(Segment Mode)

(a) 4-bit Parallel Input Mode

MD	L/R	EIO <sub>1</sub>	EIO <sub>2</sub>	DATA INPUT	NUMBER OF CLOCKS						
					40 CLOCK	39 CLOCK	38 CLOCK	...	3 CLOCK	2 CLOCK	1 CLOCK
L	L	Output	Input	DI0	Y1	Y5	Y9	...	Y149	Y153	Y157
				DI1	Y2	Y6	Y10	...	Y150	Y154	Y158
				DI2	Y3	Y7	Y11	...	Y151	Y155	Y159
				DI3	Y4	Y8	Y12	...	Y152	Y156	Y160
L	H	Input	Output	DI0	Y160	Y156	Y152	...	Y12	Y8	Y4
				DI1	Y159	Y155	Y151	...	Y11	Y7	Y3
				DI2	Y158	Y154	Y150	...	Y10	Y6	Y2
				DI3	Y157	Y153	Y149	...	Y9	Y5	Y1

(b) 8-bit Parallel Input Mode

MD	L/R	EIO <sub>1</sub>	EIO <sub>2</sub>	DATA INPUT	NUMBER OF CLOCKS						
					20 CLOCK	19 CLOCK	18 CLOCK	...	3 CLOCK	2 CLOCK	1 CLOCK
H	L	Output	Input	DI0	Y1	Y9	Y17	...	Y137	Y145	Y153
				DI1	Y2	Y10	Y18	...	Y138	Y146	Y154
				DI2	Y3	Y11	Y19	...	Y139	Y147	Y155
				DI3	Y4	Y12	Y20	...	Y140	Y148	Y156
				DI4	Y5	Y13	Y21	...	Y141	Y149	Y157
				DI5	Y6	Y14	Y22	...	Y142	Y150	Y158
				DI6	Y7	Y15	Y23	...	Y143	Y151	Y159
				DI7	Y8	Y16	Y24	...	Y144	Y152	Y160
H	H	Input	Output	DI0	Y160	Y152	Y144	...	Y24	Y16	Y8
				DI1	Y159	Y151	Y143	...	Y23	Y15	Y7
				DI2	Y158	Y150	Y142	...	Y22	Y14	Y6
				DI3	Y157	Y149	Y141	...	Y21	Y13	Y5
				DI4	Y156	Y148	Y140	...	Y20	Y12	Y4
				DI5	Y155	Y147	Y139	...	Y19	Y11	Y3
				DI6	Y154	Y146	Y138	...	Y18	Y10	Y2
				DI7	Y153	Y145	Y137	...	Y17	Y9	Y1

(Common Mode)

MD	L/R	DATA TRANSFER DIRECTION	EIO <sub>1</sub>	EIO <sub>2</sub>	DI <sub>7</sub>
L (Single)	L	Y <sub>160</sub> → Y <sub>1</sub>	Output	Input	X
	H	Y <sub>1</sub> → Y <sub>160</sub>	Input	Output	X
H (Dual)	L	Y <sub>160</sub> → Y <sub>81</sub> ----- Y <sub>80</sub> → Y <sub>1</sub>	Output	Input	Input
	H	Y <sub>1</sub> → Y <sub>80</sub> ----- Y <sub>81</sub> → Y <sub>160</sub>	Input	Output	Input

NOTES:

- L : V<sub>SS</sub> (0 V), H : V<sub>DD</sub> (+2.5 to +5.5 V), X : Don't care
- "Don't care" should be fixed to "H" or "L", avoiding floating.

7.2.3 Connection examples of plural segment drivers

(c) When L/R = "L"

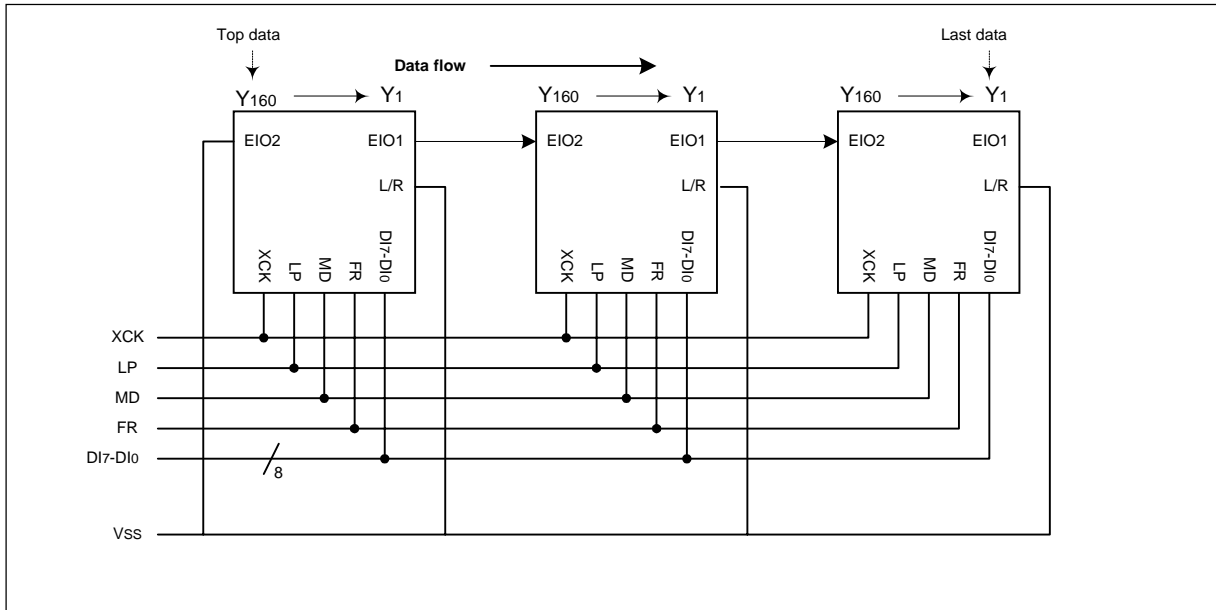

(d) When L/R = "H"

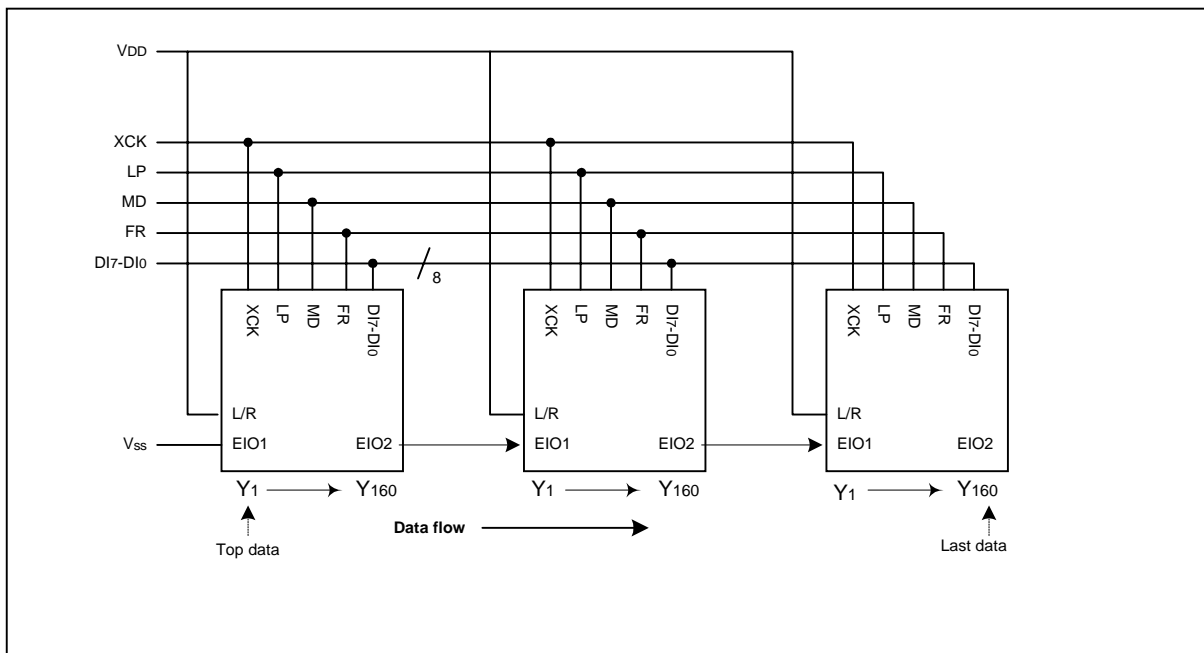

7.2.4 Timing chart of 4-device cascade connection of segment drivers

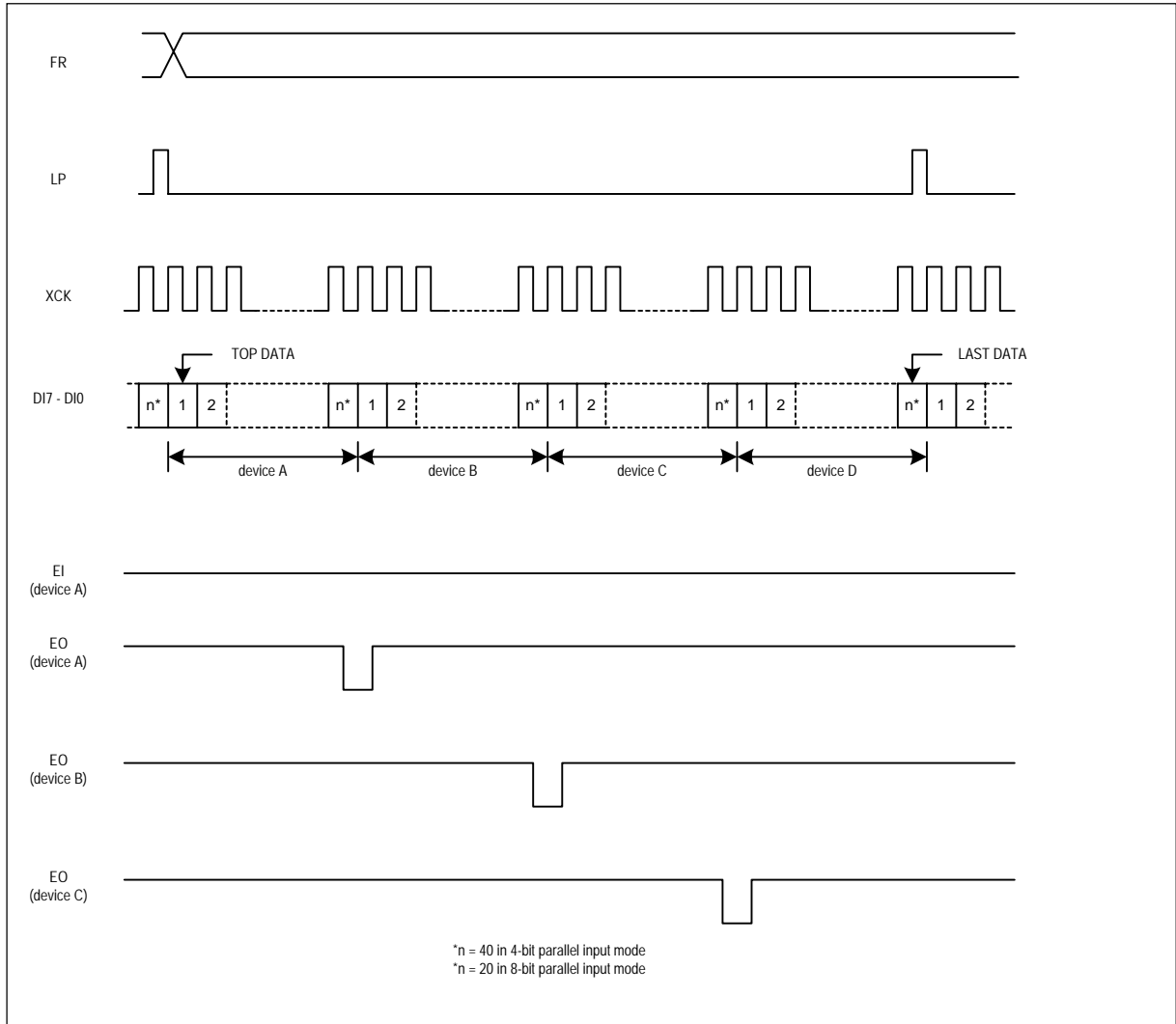

7.2.5 Connection examples for plural common drivers

(e) Single Mode (L/R = "L")

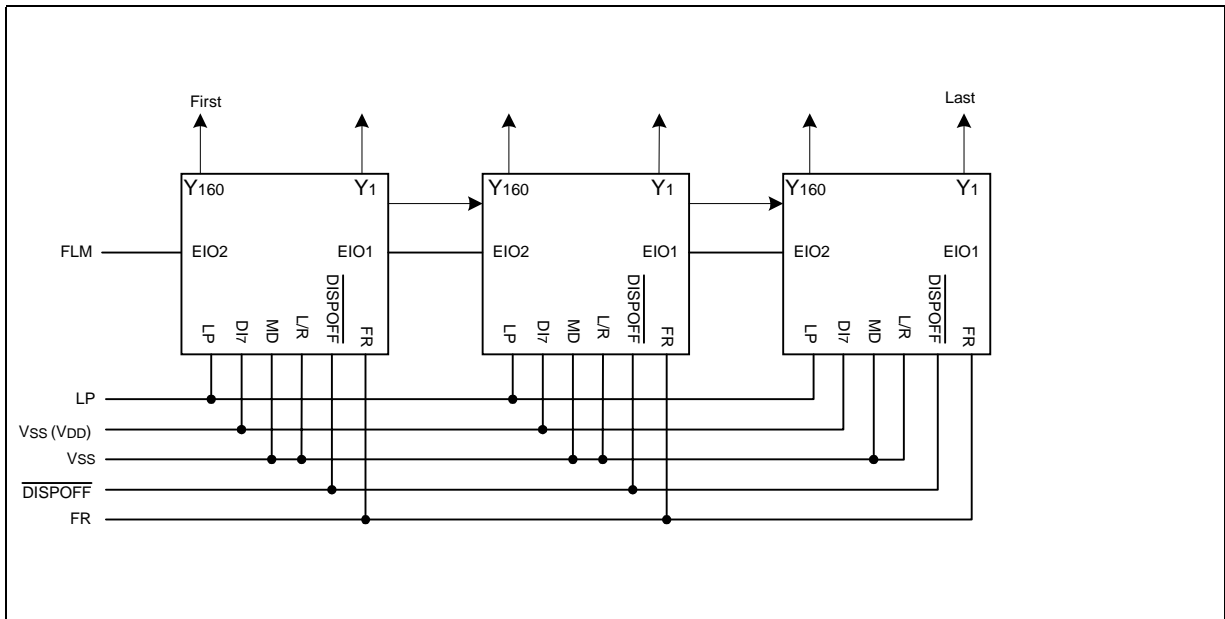

(f) Single Mode (L/R = "H")

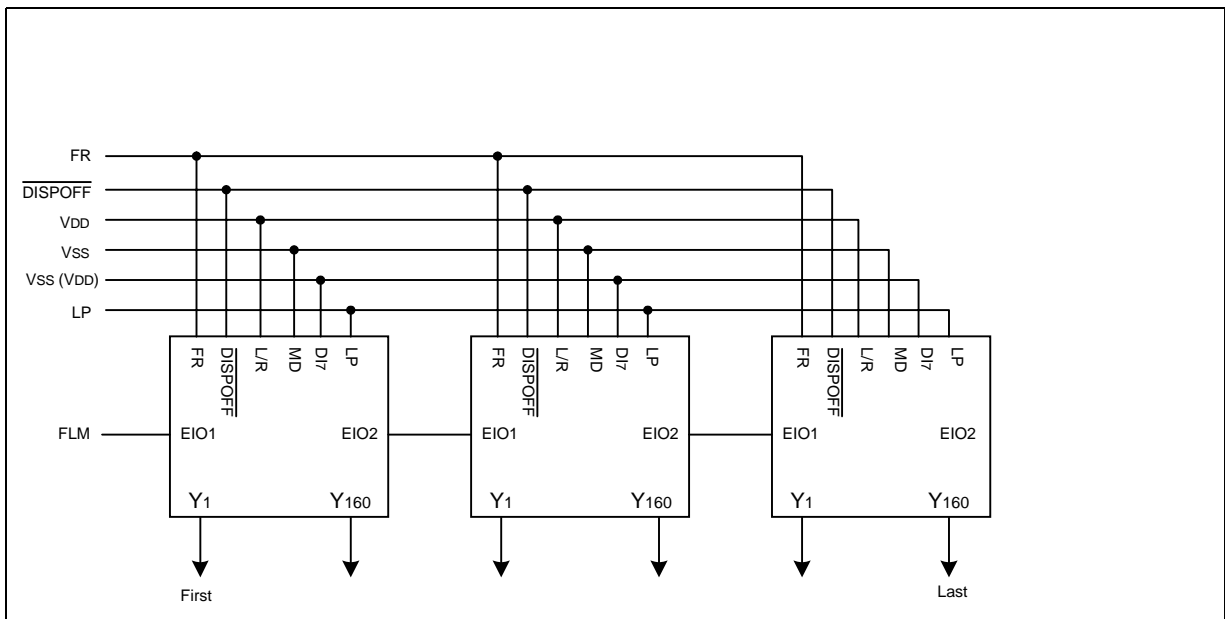

(g) Dual Mode (L/R = "L")

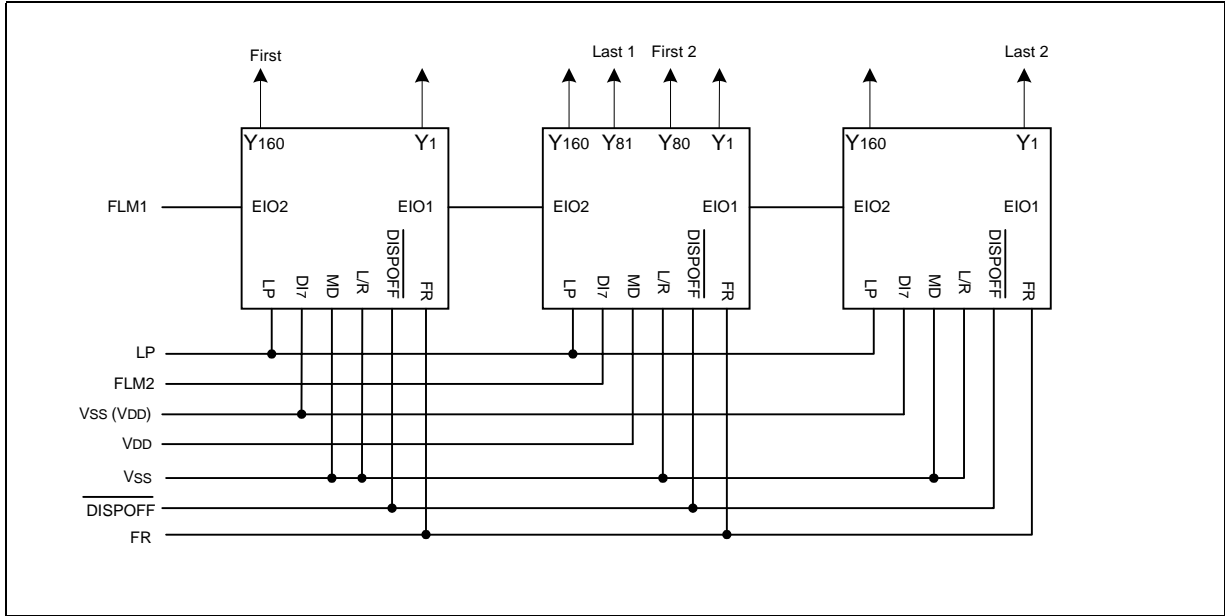

(h) Dual mode (L/R = "H")

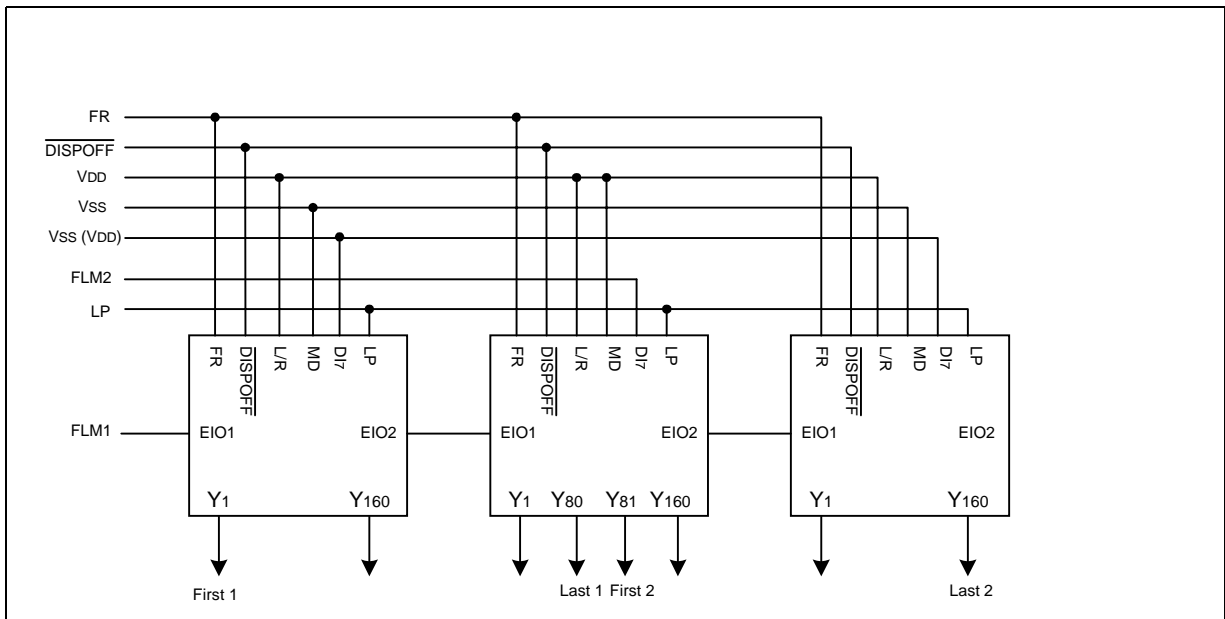

## 8. PRECAUTIONS

### Precautions when connecting or disconnecting the power supply

This IC has a high-voltage LCD driver, so a high current that may flow if voltage is supplied to the LCD drive power supply while the logic system power supply is floating may permanently damage it. The details are as follows,

- When connecting the power supply, connect the LCD drive power after connecting the logic system power. Furthermore, when disconnecting the power, disconnect the logic system power after disconnecting the LCD drive power
- It is advisable to connect the serial resistor (50 to 100 Ω) or fuse to the LCD drive power  $V_0$  of the

system as a current limiter. Set up a suitable value of the resistor in consideration of the display grade.

And when connecting the logic power supply, the logic condition of this IC inside is insecure. Therefore connect the LCD drive power supply after resetting logic condition of this IC inside on /DISPOFF function. After that, cancel the /DISPOFF function after the LCD drive power supply has become stable. Furthermore, when disconnecting the power, set the LCD drive output pins to level  $V_{ss}$  on /DISPOFF function. Then disconnect the logic system power after disconnecting the LCD drive power.

When connecting the power supply, follow the recommended sequence shown here

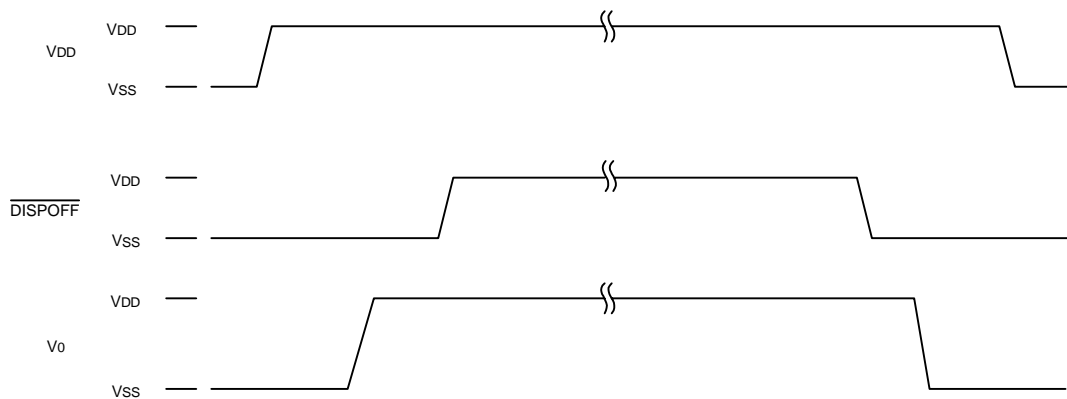

## 9. ABSOLUTE MAXIMUM RATINGS

PARAMETER	SYMBOL	APPLICABLE PINS	RATING	UNIT	NOTE
Supply voltage (1)	$V_{DD}$	$V_{DD}$	-0.3~ +7.0	V	1,2
Supply voltage (2)	$V_0$	$V_{0L}, V_{0R}$	-0.3 ~ +45.0	V	
	$V_{12}$	$V_{12L}, V_{12R}$	$V_0 -10\sim V_0 + 0.3$	V	
	$V_{43}$	$V_{43L}, V_{43R}$	$-0.3 \sim V_{SS} + 10$	V	
Input voltage	$V_i$	D17-DI0, XCK, LP, L/R, FR, MD, S/C, EIO1, EIO2, /DISPOFF, TEST1	-0.3 to $V_{DD} + 0.3$	V	
Storage temperature	$T_{STG}$		-45 to +125	°C	

### NOTES:

1.  $T_A = +25\text{ °C}$
2. The maximum applicable voltage on any pin with respect to  $V_{SS}$  (0 V).

## 10. RECOMMENDED OPERATING CONDITIONS

PARAMETER	SYMBOL	APPLICABLE PINS	MIN.	TYP.	MAX.	UNIT	NOTE
Supply voltage (1)	$V_{DD}$	$V_{DD}$	+2.5		+5.5	V	1, 2
Supply voltage (2)	$V_0$	$V_{0L}, V_{0R}$	+15.0		+40.0	V	
Operating temperature	$T_{OPR}$		-25		+85	°C	

### NOTES:

1. The applicable voltage on any pin with respect to  $V_{SS}$  (0 V).
2. Ensure that voltages are set such that  $V_{SS} < V_{43} < V_{12} < V_0$ .

## 11. ELECTRICAL CHARACTERISTICS

### 11.1 DC Characteristics

(Segment Mode) ( $V_{SS} = 0\text{ V}$ ,  $V_{DD} = +2.5\text{ to }+5.5\text{ V}$ ,  $V_0 = +15.0\text{ to }+30.0\text{ V}$ ,  $T_{OPR} = -25\text{ to }+85^\circ\text{C}$ )

PARAMETER	SYMBOL	CONDITIONS	APPLICABLE PINS	MIN.	TYP.	MAX.	UNIT	NOTE
Input "Low" voltage	$V_{IL}$		DI7-DI0, XCK, LP, L/R			$0.2V_{DD}$	V	
Input "High" voltage	$V_{IH}$		FR, MD, S/C, EIO <sub>1</sub> , EIO <sub>2</sub> , /DISPOFF	$0.8V_{DD}$			V	
Output "Low" voltage	$V_{OL}$	$I_{OL} = +0.4\text{ mA}$	EIO <sub>1</sub> , EIO <sub>2</sub>			+0.4	V	
Output "High" voltage	$V_{OH}$	$I_{OH} = -0.4\text{ mA}$		$V_{DD}-0.4$				V
Input leakage current	$I_{LIL}$	$V_i = V_{SS}$	DI7-DI0, XCK, LP, LIR, FR, MD, S/C, EIO <sub>1</sub> , EIO <sub>2</sub> , /DISPOFF			-10	$\mu\text{A}$	
	$I_{LIH}$	$V_i = V_{DD}$				+10	$\mu\text{A}$	
Output resistance	$R_{ON}$	$\frac{ \Delta V_{ON} }{=0.5\text{V}}$ $V_0 = 30\text{ V}$	Y <sub>1</sub> -Y <sub>160</sub>		1.0	1.5	k $\Omega$	
Standby current	$I_{STB}$		$V_{SS}$			50	$\mu\text{A}$	1
Supply current (1) (Non-selection)	$I_{DD1}$		$V_{DD}$			2.0	mA	2
Supply current (2) (Selection)	$I_{DD2}$		$V_{DD}$			7.0	mA	3
Supply current (3)	$I_0$		$V_{OL}$ , $V_{OR}$			0.9	mA	4

#### NOTES:

- $V_{DD} = +5.0\text{ V}$ ,  $V_0 = +30.0\text{ V}$ ,  $V_i = V_{SS}$ .
- $V_{DD} = +5.0\text{ V}$ ,  $V_0 = +30.0\text{ V}$ ,  $f_{XCK} = 8\text{ MHz}$ , no-load,  $EI = V_{DD}$ . The input data is turned over by data taking clock (4-bit parallel input mode).
- $V_{DD} = +5.0\text{ V}$ ,  $V_0 = +30.0\text{ V}$ ,  $f_{XCK} = 8\text{ MHz}$ , no-load,  $EI = V_{SS}$ . The input data is turned over by data taking clock (4-bit parallel input mode).
- $V_{DD} = +5.0\text{ V}$ ,  $V_0 = +30.0\text{ V}$ ,  $f_{XCK} = 8\text{ MHz}$ ,  $f_{LP} = 19.2\text{ kHz}$ ,  $f_{FR} = 80\text{ Hz}$ , no-load. The input data is turned over by data taking clock (4-bit parallel input mode).

(Common Mode) ( $V_{SS} = 0\text{ V}$ ,  $V_{DD} = +2.5\text{ to }+5.5\text{ V}$ ,  $V_0 = +15.0\text{ to }+30.0\text{ V}$ ,  $T_{OPR} = -25\text{ to }+85^\circ\text{C}$ )

PARAMETER	SYMBOL	CONDITIONS	APPLICABLE PINS	MIN.	TYP.	MAX.	UNIT	NOTE
Input "Low" voltage	$V_{IL}$		DI7-DI0, XCK, LP, L/R			$0.2V_{DD}$	V	
Input "High" voltage	$V_{IH}$		FR, MD, S/C, EIO <sub>1</sub> , EIO <sub>2</sub> , /DISPOFF	$0.8V_{DD}$			V	
Output "Low" voltage	$V_{OL}$	$I_{OL} = +0.4\text{ mA}$	EIO <sub>1</sub> , EIO <sub>2</sub>			+0.4	V	
Output "High" voltage	$V_{OH}$	$I_{OH} = -0.4\text{ mA}$		$V_{DD}-0.4$				V
Input leakage current	$I_{LIL}$	$V_i = V_{SS}$	DI7-DI0, XCK, LP, LIR, FR, MD, S/C, EIO <sub>1</sub> , EIO <sub>2</sub> , /DISPOFF			-10.0	$\mu\text{A}$	
	$I_{LIH}$	$V_i = V_{DD}$	DI6-DI0, LP, L/R, FR, MD, S/C, /DISPOFF			+10.0	$\mu\text{A}$	
Input pull-down current	$I_{PD}$	$V_i = V_{DD}$	DI7, XCK, EIO <sub>1</sub> , EIO <sub>2</sub>			100	$\mu\text{A}$	
Output resistance	$R_{ON}$	$\frac{ \Delta V_{ON} }{=0.5\text{V}}$ $V_0 = 30\text{ V}$	Y <sub>1</sub> -Y <sub>160</sub>		1.0	1.5	k $\Omega$	
Standby current	$I_{SPD}$		$V_{SS}$			50	$\mu\text{A}$	1
Supply current (1)	$I_{DD}$		$V_{DD}$			80	$\mu\text{A}$	2
Supply current (2)	$I_0$		$V_{OL}$ , $V_{OR}$			130	$\mu\text{A}$	2

#### NOTES:

- $V_{DD} = +5.0\text{ V}$ ,  $V_0 = +30.0\text{ V}$ ,  $V_i = V_{SS}$
- $V_{DD} = +5.0\text{ V}$ ,  $V_0 = +30.0\text{ V}$ ,  $f_{LP} = 19.2\text{ kHz}$ ,  $f_{FR} = 80\text{ Hz}$ , 1/240 duty operation, no-load.



## 11.2 AC Characteristics

(Segment Mode 1) ( $V_{SS} = 0\text{ V}$ ,  $V_{DD} = +2.5\text{ to }+3.0\text{ V}$ ,  $V_0 = +15.0\text{ to }+30.0\text{ V}$ ,  $T_{OPR} = -25\text{ to }+85\text{ }^\circ\text{C}$ )

PARAMETER	SYMBOL	CONDITIONS	MIN	TYP.	MAX.	UNIT	NOTE
Shift clock period	$t_{WCK}$	$t_r, t_f \leq 11\text{ ns}$	125			ns	1
Shift clock "H" pulse width	$t_{WCKH}$		51			ns	
Shift clock "L" pulse width	$t_{WCKL}$		51			ns	
Data setup time	$t_{DS}$		30			ns	
Data hold time	$t_{DH}$		40			ns	
Latch pulse "H" pulse width	$t_{WLPH}$		51			ns	
Shift clock rise to latch pulse rise time	$t_{LD}$		0			ns	
Shift clock fall to latch pulse fall time	$t_{SL}$		51			ns	
Latch pulse rise to shift clock rise time	$t_{LS}$		51			ns	
Latch pulse fall to shift clock fall time	$t_{LH}$		51			ns	
Enable setup time	$t_s$		36			ns	
Input signal rise time	$t_r$				50	ns	2
Input signal fall time	$t_f$				50	ns	2
DISPOFF removal time	$t_{SD}$		100			ns	
DISPOFF "L" pulse width	$t_{WDL}$		1.2			$\mu\text{s}$	
Output delay time (1)	$t_d$	$CL = 15\text{ pF}$			78	ns	
Output delay time (2)	$t_{PD1}, t_{PD2}$	$CL = 15\text{ pF}$			1.2	$\mu\text{s}$	
Output delay time (3)	$t_{PD3}$	$CL = 15\text{ pF}$			1.2	$\mu\text{s}$	

## NOTES:

1. Takes the cascade connection into consideration.
2.  $(t_{WCK} - t_{WCKH} - t_{WCKL})/2$  is maximum in the case of high speed operation.

(Segment Mode 2) ( $V_{SS} = 0\text{ V}$ ,  $V_{DD} = +5.0 \pm 0.5\text{ V}$ ,  $V_0 = +15.0\text{ to }+30.0\text{ V}$ ,  $T_{OPR} = -25\text{ to }+85\text{ }^\circ\text{C}$ )

PARAMETER	SYMBOL	CONDITIONS	MIN.	TYP.	MAX.	UNIT	NOTE
Shift clock period	$t_{WCK}$	$t_r, t_f \leq 10\text{ ns}$	66			ns	1
Shift clock "H" pulse width	$t_{WCKH}$		23			ns	
Shift clock "L" pulse width	$t_{WCKL}$		23			ns	
Data setup time	$t_{DS}$		15			ns	
Data hold time	$t_{DH}$		23			ns	
Latch pulse "H" pulse width	$t_{WLPH}$		30			ns	
Shift clock rise to latch pulse rise time	$t_{LD}$		0			ns	
Shift clock fall to latch pulse fall time	$t_{SL}$		50			ns	
Latch pulse rise to shift clock rise time	$t_{LS}$		30			ns	
Latch pulse fall to shift clock fall time	$t_{LH}$		30			ns	
Enable setup time	$t_s$		15			ns	
Input signal rise time	$t_r$				50	ns	2
Input signal fall time	$t_f$				50	ns	2
DISPOFF removal time	$t_{SD}$		100			ns	
DISPOFF "L" pulse width	$t_{WDL}$		1.2			$\mu\text{s}$	
Output delay time (1)	$t_d$	$CL = 15\text{ pF}$			41	ns	
Output delay time (2)	$t_{PD1}, t_{PD2}$	$CL = 15\text{ pF}$			1.2	$\mu\text{s}$	
Output delay time (3)	$t_{PD3}$	$CL = 15\text{ pF}$			1.2	$\mu\text{s}$	

## NOTES:

1. Takes the cascade connection into consideration.
2.  $(t_{WCK} - t_{WCKH} - t_{WCKL})/2$  is maximum in the case of high speed operation.

(Segment Mode 3) ( $V_{SS} = 0\text{ V}$ ,  $V_{DD} = +3.0\text{ to }+4.5\text{ V}$ ,  $V_0 = +15.0\text{ to }+30.0\text{ V}$ ,  $T_{OPR} = -25\text{ to }+85\text{ }^{\circ}\text{C}$ )

PARAMETER	SYMBOL	CONDITIONS	MIN.	TYP.	MAX.	UNIT	NOTE
Shift clock period	$t_{WCK}$	$t_R, t_F \leq 10\text{ns}$	82			ns	1
Shift clock "H" pulse width	$t_{WCKH}$		28			ns	
Shift clock "L" pulse width	$t_{WCKL}$		28			ns	
Data setup time	$t_{DS}$		20			ns	
Data hold time	$t_{DH}$		23			ns	
Latch pulse "H" pulse width	$t_{WLPH}$		30			ns	
Shift clock rise to latch pulse rise time	$t_{LD}$		0			ns	
Shift clock fall to latch pulse fall time	$t_{SL}$		51			ns	
Latch pulse rise to shift clock rise time	$t_{LS}$		30			ns	
Latch pulse fall to shift clock fall time	$t_{LH}$		30			ns	
Enable setup time	$t_S$		15			ns	
Input signal rise time	$t_R$				50	ns	2
Input signal fall time	$t_F$				50	ns	2
DISPOFF removal time	$t_{SD}$		100			ns	
DISPOFF "L" pulse width	$t_{WDL}$		1.2			$\mu\text{s}$	
Output delay time (1)	$t_D$	$CL = 15\text{ pF}$			57	ns	
Output delay time (2)	$t_{PD1}, t_{PD2}$	$CL = 15\text{ pF}$			1.2	$\mu\text{s}$	
Output delay time (3)	$t_{PD3}$	$CL = 15\text{ pF}$			1.2	$\mu\text{s}$	

**NOTES:**

1. Takes the cascade connection into consideration.
2.  $(t_{WCK} - t_{WCKH} - t_{WCKL})/2$  is maximum in the case of high speed operation.

(Common Mode) ( $V_{SS} = 0\text{ V}$ ,  $V_{DD} = +2.5\text{ to }+5.5\text{ V}$ ,  $V_0 = +15.0\text{ to }+30.0\text{ V}$ ,  $T_{OPR} = -25\text{ to }+85\text{ }^{\circ}\text{C}$ )

PARAMETER	SYMBOL	CONDITIONS	MIN	TYP	MAX	UNIT
Shift clock period	$t_{WLP}$	$t_R, t_F 20\text{ns}$	250			ns
Shift clock "H" pulse width	$t_{WLPH}$	$V_{DD}=5\pm 0.5\text{V}$ $V_{DD}=2.5\sim 4.5\text{V}$	15 30			ns
Data setup time	$t_{SU}$		30			ns
Data hold time	$t_H$		50			ns
Input signal rise time	$t_R$				50	ns
Input signal fall time	$t_F$				50	ns
DISPOFF removal time	$t_{SD}$		100			ns
DISPOFF "L" pulse width	$t_{WDL}$		1.2			$\mu\text{s}$
Output delay time (1)	$t_{DL}$	$CL=10\text{pF}$			200	ns
Output delay time (2)	$t_{PD1}, t_{PD2}$	$CL=10\text{pF}$			1.2	$\mu\text{s}$
Output delay time (3)	$t_{PD3}$	$CL=10\text{pF}$			1.2	$\mu\text{s}$

11.3 Timing Chart of Segment Mode

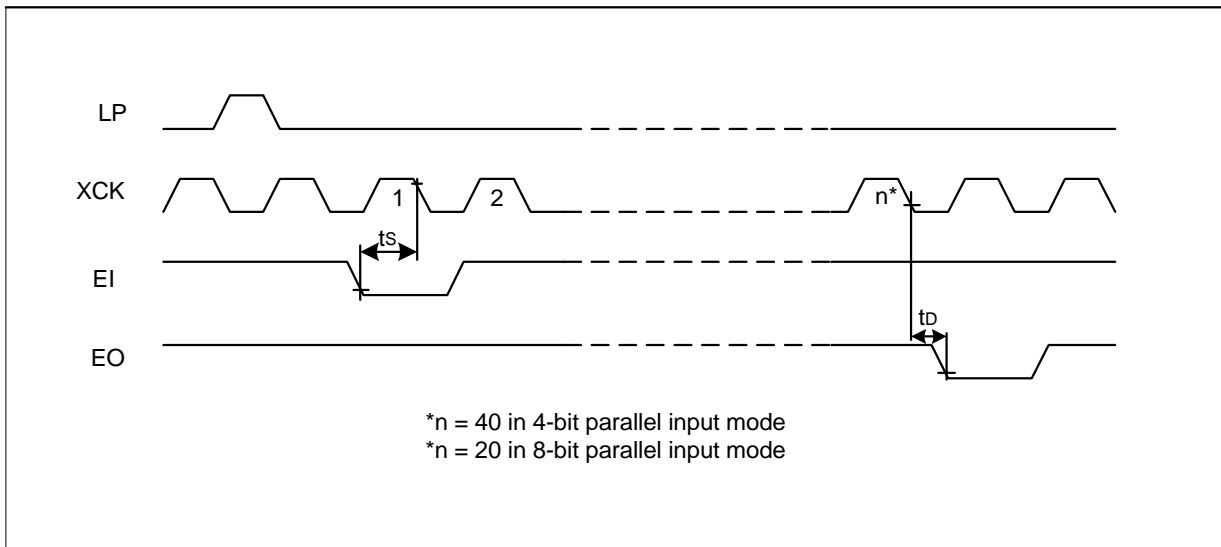
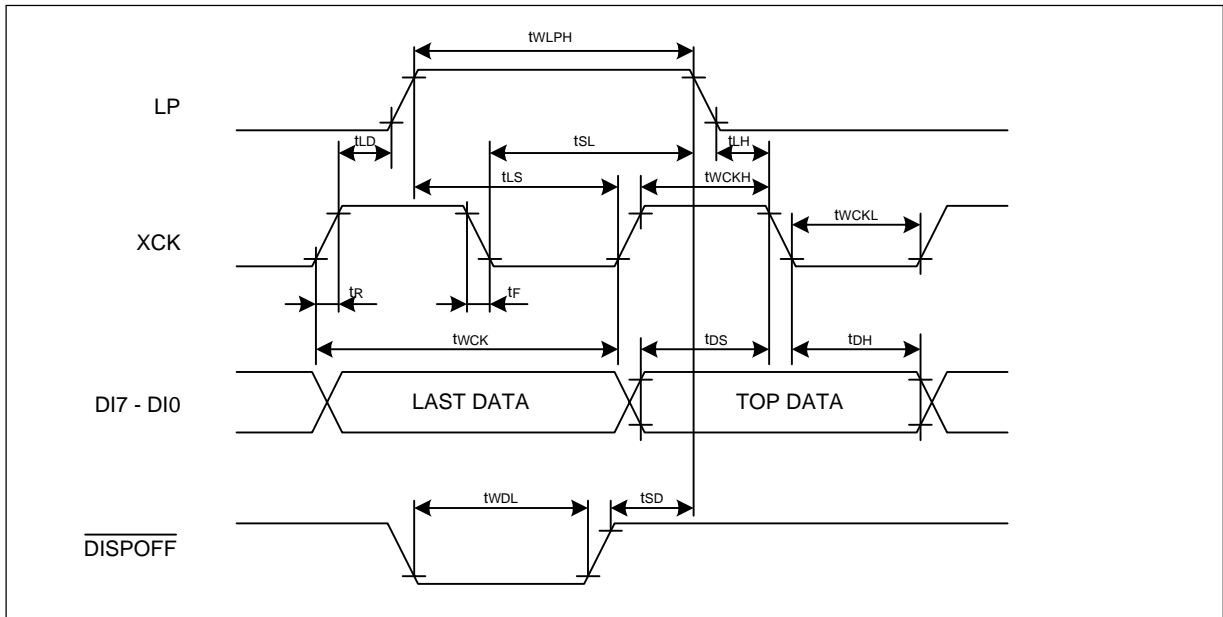

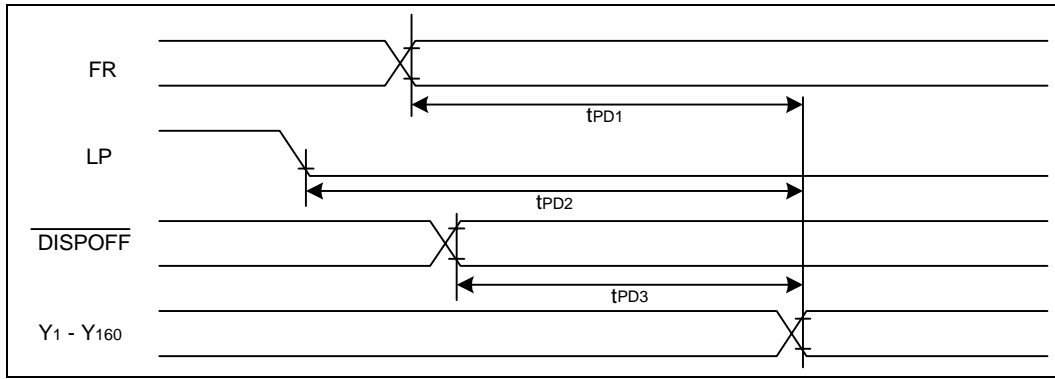
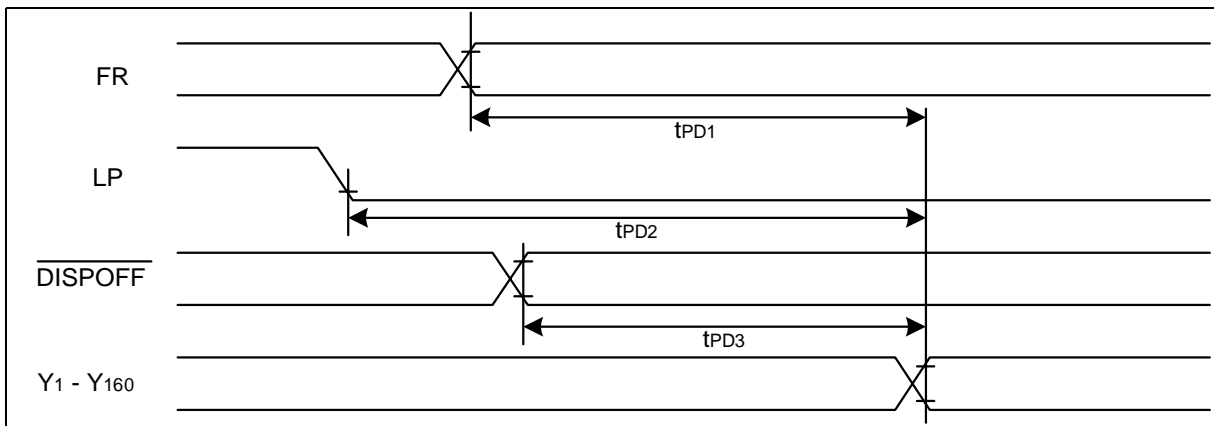
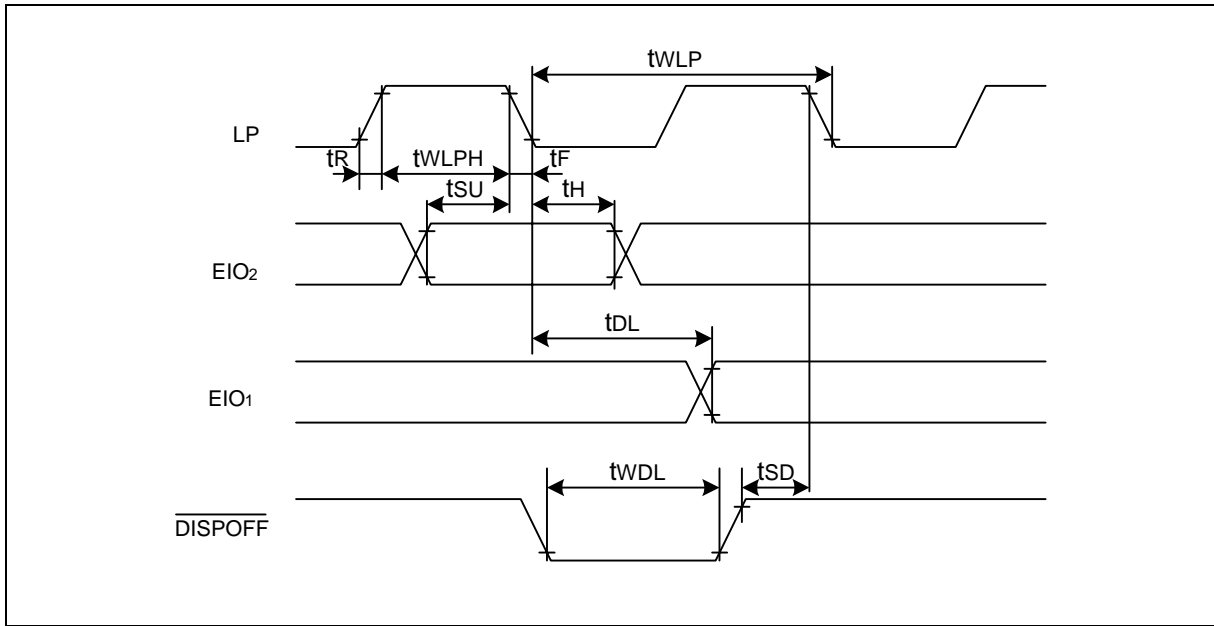

Fig. 8 Timing Characteristics (3)

(Common Mode) ( $V_{SS} = 0\text{ V}$ ,  $V_{DD} = +2.5\text{ to }+5.5\text{ V}$ ,  $V_0 = +15.0\text{ to }+30.0\text{ V}$ ,  $T_{OPR} = -25\text{ to }+85^\circ\text{ C}$ )

PARAMETER	SYMBOL	CONDITIONS	MIN.	TYP.	MAX.	UNIT
Shift clock period	$t_{WLP}$	$t_R, t_F \leq 20\text{ ns}$	250			ns
Shift clock "H" pulse width	$t_{WLPH}$	$V_{DD} = +5.0 \pm 0.5\text{ V}$	15			ns
		$V_{DD} = +2.5\text{ to }4.5\text{ V}$	30			ns
Data setup time	$t_{SU}$		30			ns
Data hold time	$t_H$		50			ns
Input signal rise time	$t_R$				50	ns
Input signal fall time	$t_F$				50	ns
DISPOFF removal time	$t_{SD}$		100			ns
DISPOFF "L" pulse width	$t_{WDL}$		1.2			$\mu\text{s}$
Output delay time (1)	$t_{DL}$	$C_L = 15\text{ pF}$			200	ns
Output delay time (2)	$t_{PD1}, t_{PD2}$	$C_L = 15\text{ pF}$			1.2	$\mu\text{s}$
Output delay time (3)	$t_{PD3}$	$C_L = 15\text{ pF}$			1.2	$\mu\text{s}$

11.4 Timing Chart of Common Mode



## 12.APPLICATION CIRCUIT

### 12.1 Application Circuit for Module

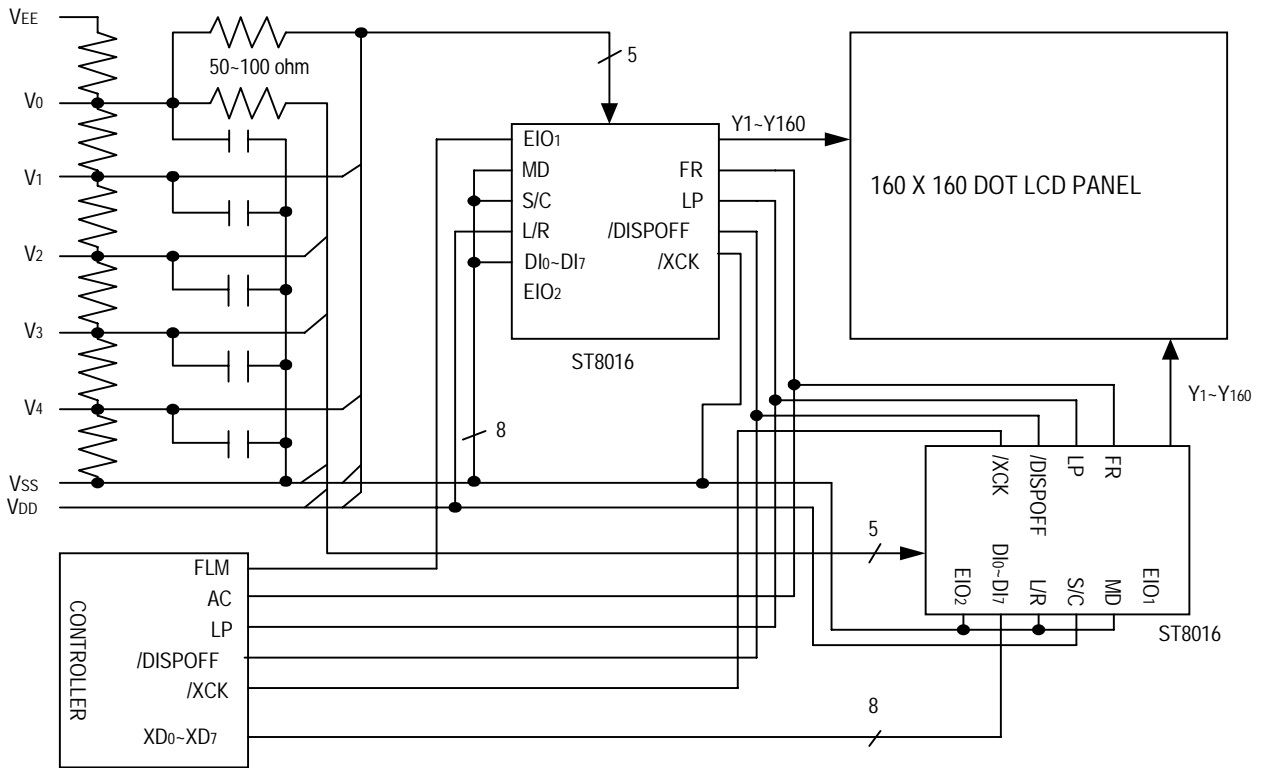

### 12.2 Application Circuit for COG Layout ( Example )

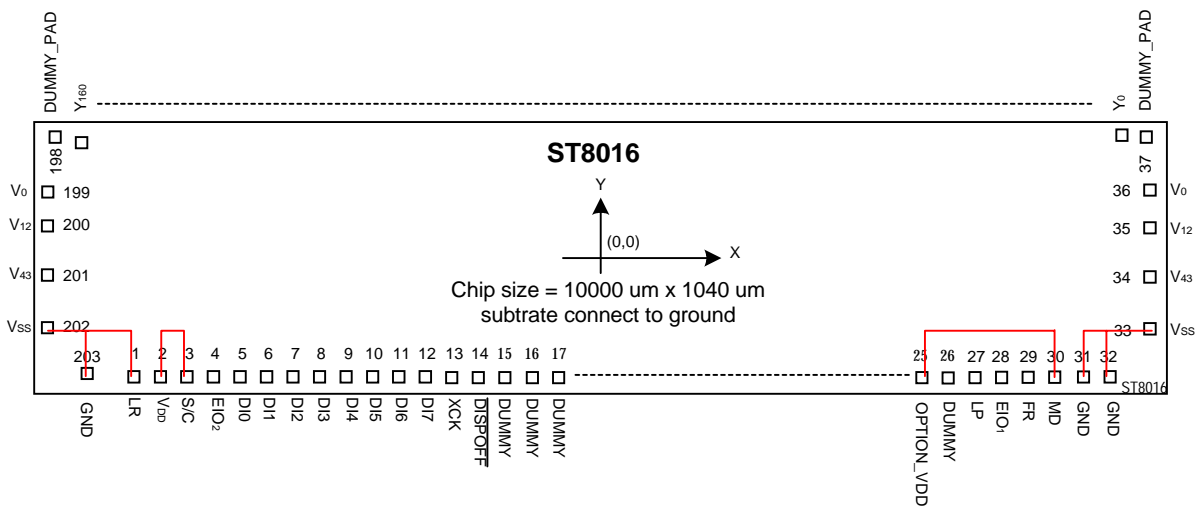

### 13. PAD DIAGRAM

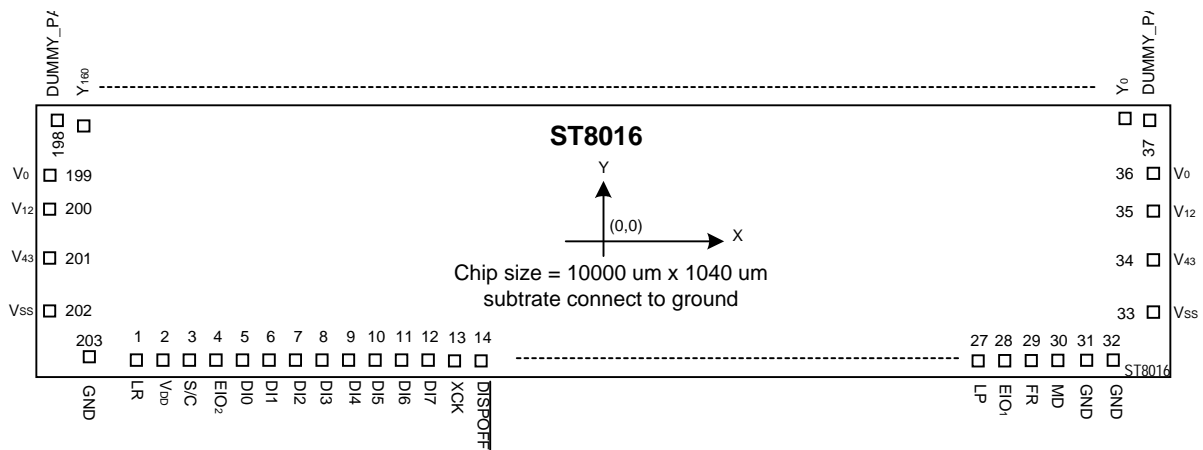

Unit: um

PIN#	Name	X	Y	PIN#	Name	X	Y
1	L/R	-4538.6	-406.9	34	V34	4904.5	-125.7
2	VDD	-4227.0	-409.7	35	V12	4904.5	90.7
3	S/C	-4074.5	-406.9	36	V0	4904.5	265.9
4	EIO2	-3607.4	-406.9	37	DUMMY_PAD	4890.0	438.3
5	DI0	-3413.4	-406.9	38	Y1	4770.0	383.8
6	DI1	-3056.4	-406.9	39	Y2	4710.0	383.8
7	DI2	-2862.4	-406.9	40	Y3	4650.0	383.8
8	DI3	-2505.9	-406.9	41	Y4	4590.0	383.8
9	DI4	-2311.9	-406.9	42	Y5	4530.0	383.8
10	DI5	-1955.6	-406.9	43	Y6	4470.0	383.8
11	DI6	-1761.6	-406.9	44	Y7	4410.0	383.8
12	DI7	-1355.9	-406.9	45	Y8	4350.0	383.8
13	XCK	-1161.9	-406.9	46	Y9	4290.0	383.8
14	DISPOFFB	-741.5	-406.9	47	Y10	4230.0	383.8
15	DUMMY_PAD	-586.0	-419.2	48	Y11	4170.0	383.8
16	DUMMY_PAD	-70.4	-421.5	49	Y12	4110.0	383.8
17	DUMMY_PAD	152.5	-398.3	50	Y13	4050.0	383.8
18	DUMMY_PAD	400.6	-394.3	51	Y14	3990.0	383.8
19	DUMMY_PAD	768.3	-398.7	52	Y15	3930.0	383.8
20	DUMMY_PAD	1183.9	-398.7	53	Y16	3870.0	383.8
21	DUMMY_PAD	1474.6	-395.3	54	Y17	3810.0	383.8
22	DUMMY_PAD	1595.8	-411.9	55	Y18	3750.0	383.8
23	DUMMY_PAD	2092.5	-412.6	56	Y19	3690.0	383.8
24	DUMMY_PAD	2318.2	-404.5	57	Y20	3630.0	383.8
25	OPTION_VDD	2744.0	-407.1	58	Y21	3570.0	383.8
26	DUMMY_PAD	3082.8	-407.1	59	Y22	3510.0	383.8
27	LP	3220.8	-406.9	60	Y23	3450.0	383.8
28	EIO1	3701.6	-406.9	61	Y24	3390.0	383.8
29	FR	3895.6	-406.9	62	Y25	3330.0	383.8
30	MD	4313.0	-406.9	63	Y26	3270.0	383.8
31	GND	4525.0	-406.9	64	Y27	3210.0	383.8
32	GND	4720.4	-404.3	65	Y28	3150.0	383.8
33	V5	4904.5	-344.1	66	Y29	3090.0	383.8

67	Y30	3030.0	383.8	118	Y81	-30.0	383.8
68	Y31	2970.0	383.8	119	Y82	-90.0	383.8
69	Y32	2910.0	383.8	120	Y83	-150.0	383.8
70	Y33	2850.0	383.8	121	Y84	-210.0	383.8
71	Y34	2790.0	383.8	122	Y85	-270.0	383.8
72	Y35	2730.0	383.8	123	Y86	-330.0	383.8
73	Y36	2670.0	383.8	124	Y87	-390.0	383.8
74	Y37	2610.0	383.8	125	Y88	-450.0	383.8
75	Y38	2550.0	383.8	126	Y89	-510.0	383.8
76	Y39	2490.0	383.8	127	Y90	-570.0	383.8
77	Y40	2430.0	383.8	128	Y91	-630.0	383.8
78	Y41	2370.0	383.8	129	Y92	-690.0	383.8
79	Y42	2310.0	383.8	130	Y93	-750.0	383.8
80	Y43	2250.0	383.8	131	Y94	-810.0	383.8
81	Y44	2190.0	383.8	132	Y95	-870.0	383.8
82	Y45	2130.0	383.8	133	Y96	-930.0	383.8
83	Y46	2070.0	383.8	134	Y97	-990.0	383.8
84	Y47	2010.0	383.8	135	Y98	-1050.0	383.8
85	Y48	1950.0	383.8	136	Y99	-1110.0	383.8
86	Y49	1890.0	383.8	137	Y100	-1170.0	383.8
87	Y50	1830.0	383.8	138	Y101	-1230.0	383.8
88	Y51	1770.0	383.8	139	Y102	-1290.0	383.8
89	Y52	1710.0	383.8	140	Y103	-1350.0	383.8
90	Y53	1650.0	383.8	141	Y104	-1410.0	383.8
91	Y54	1590.0	383.8	142	Y105	-1470.0	383.8
92	Y55	1530.0	383.8	143	Y106	-1530.0	383.8
93	Y56	1470.0	383.8	144	Y107	-1590.0	383.8
94	Y57	1410.0	383.8	145	Y108	-1650.0	383.8
95	Y58	1350.0	383.8	146	Y109	-1710.0	383.8
96	Y59	1290.0	383.8	147	Y110	-1770.0	383.8
97	Y60	1230.0	383.8	148	Y111	-1830.0	383.8
98	Y61	1170.0	383.8	149	Y112	-1890.0	383.8
99	Y62	1110.0	383.8	150	Y113	-1950.0	383.8
100	Y63	1050.0	383.8	151	Y114	-2010.0	383.8
101	Y64	990.0	383.8	152	Y115	-2070.0	383.8
102	Y65	930.0	383.8	153	Y116	-2130.0	383.8
103	Y66	870.0	383.8	154	Y117	-2190.0	383.8
104	Y67	810.0	383.8	155	Y118	-2250.0	383.8
105	Y68	750.0	383.8	156	Y119	-2310.0	383.8
106	Y69	690.0	383.8	157	Y120	-2370.0	383.8
107	Y70	630.0	383.8	158	Y121	-2430.0	383.8
108	Y71	570.0	383.8	159	Y122	-2490.0	383.8
109	Y72	510.0	383.8	160	Y123	-2550.0	383.8
110	Y73	450.0	383.8	161	Y124	-2610.0	383.8
111	Y74	390.0	383.8	162	Y125	-2670.0	383.8
112	Y75	330.0	383.8	163	Y126	-2730.0	383.8
113	Y76	270.0	383.8	164	Y127	-2790.0	383.8
114	Y77	210.0	383.8	165	Y128	-2850.0	383.8
115	Y78	150.0	383.8	166	Y129	-2910.0	383.8
116	Y79	90.0	383.8	167	Y130	-2970.0	383.8
117	Y80	30.0	383.8	168	Y131	-3030.0	383.8



169	Y132	-3090.0	383.8	187	Y150	-4170.0	383.8
170	Y133	-3150.0	383.8	188	Y151	-4230.0	383.8
171	Y134	-3210.0	383.8	189	Y152	-4290.0	383.8
172	Y135	-3270.0	383.8	190	Y153	-4350.0	383.8
173	Y136	-3330.0	383.8	191	Y154	-4410.0	383.8
174	Y137	-3390.0	383.8	192	Y155	-4470.0	383.8
175	Y138	-3450.0	383.8	193	Y156	-4530.0	383.8
176	Y139	-3510.0	383.8	194	Y157	-4590.0	383.8
177	Y140	-3570.0	383.8	195	Y158	-4650.0	383.8
178	Y141	-3630.0	383.8	196	Y159	-4710.0	383.8
179	Y142	-3690.0	383.8	197	Y160	-4770.0	383.8
180	Y143	-3750.0	383.8	198	DUMMY_PAD	-4890.0	438.3
181	Y144	-3810.0	383.8	199	V0	-4904.5	265.9
182	Y145	-3870.0	383.8	200	V12	-4904.5	90.7
183	Y146	-3930.0	383.8	201	V34	-4904.5	-125.7
184	Y147	-3990.0	383.8	202	V5	-4904.5	-344.1
185	Y148	-4050.0	383.8	203	GND	-4781.8	-404.9
186	Y149	-4110.0	383.8				

## 13.1 Gold Bump size (unit: um)

Pad No.	X	Y	Area (um <sup>2</sup> )
38~197	45	72	3240
1~14,17,27~32,203	62	58	3596
33~36,199~202	58	62	3596
15,16,18,21~26	38	60	2280
19,20	60	38	2280
37,198	85	60	5100

Bump pad height (pad 1~198) = 18um, strength=30g

## Appendix:

2000-May-16.....	Page1, modify pin configuration
2000-Jul-25 .....	Application circuit
2000-Aug-1 .....	Pad allocation, Bump size
2000-Aug-9(version0.14) .....	change pad name V5 as Vss
2000-Aug-17(version 0.143).....	add pad 203 gold bump data
2000-Oct-9(version 0.152) .....	add some bump information
2000-Nov-2(version 0.153).....	correct pad name
2000/Dec/4(version0.16) .....	update TCP(F18) information
2000/Dec/19(version 0.17) .....	correct all V5 as Vss
2000/Dec/26(version 0.2) .....	AC/DC data revise
2001/Feb/8(0.23).....	correct segment mode MD=L/H=4/8 bit (section 7.2.2)
2001/Mar/1(0.24).....	gold bump strength=30g
2001/May/22(0.30).....	Dual mode describe correct and COG application circuit (section 12.2)
2001/June/11(0.31).....	Correct some wrong word mistake
2001/Aug/29(0.32).....	add Input/Output circuit
2001/Sep/28(0.33).....	tSL MIN change to 51 , and change parameter name
2001/Oct/4(0.34).....	Correct AC characteristics column
2002/Jun/07(0.35).....	Change operating temperature from -20°C~85°C to -25°C~85°C