

Sitronix

ST7920

Chinese Fonts built in LCD controller/driver

Main Features

- Voltage operating range:
 - 2.7 to 5.5V
- Support 8 bit, 4 bit, serial bus MPU interface
- 64 x 16-bits character display RAM (max. 16 chars x 4 lines, LCD display range 16 char. X 2 lines)
- 64 x 256-bits graphic display RAM (GDRAM)
- 2M-bits Chinese fonts ROM (CGROM) supporting 8192 Chinese fonts (16x16 dot matrix)
- 16K-bits half height ROM (HCGROM) supporting 126 character set (16x8 dot matrix)
- 64 x 16-bits character generation RAM (CGRAM)
- 15 x 16-bits total 240 ICON RAM (IRAM)
- 33-common x 64-segment (2 lines display) LCD drivers
- Automatic power on reset
- External reset pin (XRESET)
- With extension segment drivers display area can up to 16x2 lines
- RC oscillator built in (with external R)
- Low power design
 - Normal mode (450uA Typ VDD=5V)
 - Standby mode (30uA Max VDD=5V)
- VLCD (V0~ Vss): max 7V
- Graphic and character mix modes display
- Multiple instructions :
 - (Display clear)
 - (Return home)
 - (Display on/off)
 - (Cursor on/off)
 - (Display character blink)
 - (Cursor shift)
 - (Display shift)
 - (Vertical line scroll)
 - (By_line reverse display)
 - (Standby mode)
- Built in voltage booster (2 times)
- 1/33 Duty

Function Description

ST7920 LCD controller/driver IC can display alphabets, numbers, Chinese fonts and self-defined characters. It supports 3 kinds of bus interface, namely 8 bit/ 4bit and serial. All functions, including display RAM, character generator ROM, LCD display drivers and control circuits are all in a one-chip solution. With a minimum system configuration, a Chinese character display system can easily achieved.

ST7920 includes character ROM with 8192 16X16 dots Chinese fonts and 126 16X8 dots half height alphanumerical fonts. Also for graphic display it supports 64x256 dots graphic display area (GDRAM) and 240 dots ICON RAM. Mix mode display with both character and graphic data is possible. ST7920 has built in 4 sets CGRAM providing software programmable 16X16 font.

ST7920 has wide operating voltage (2.7V to 5.5V) and low power consumption suitable for battery power portable device.

ST7920 LCD driver consists of 33 common and 64 segments. Together with extension segment driver ST7921, ST7920 can support up to 33 common x 256 segments display.

Product	Font type
ST7920-0A	BIG-5 code traditional character set
ST7920-0B	GB code simplified character set
ST7920-0C	GB code,BIG-5 code and Japanese code

ST7920 Specification Revision History		
Version	Date	Description
C1.7	2000/12/15	<ol style="list-style-type: none"> 1. VCC changed to VDD. 2. VLCD changed from VCC-V5 to V0-VSS. 3. DC characteristics input High voltage (Vih) changed to 0.7VDD. 4. DC characteristics output High voltage (Voh) changed to 0.8VDD.
C1.8	2001/03/01	<ol style="list-style-type: none"> 1. Chip Size changed. 2. ICON 256 dots changed to 240 dots. 3. XOFF normal high sleep Low changed to normal low sleep High. 4. Added XOFF application. 5. Modified application of ST7920 4,5,6 PIN floating. (4,5,6 爲 test pin) 6. Modified voltage doubler CAP1P, CAP1M, CAP2M capacitors polarity
C1.9	2001/05/28	<ol style="list-style-type: none"> 1. Icon RAM TABLE changed. (TABLE-6) 2. Booster description modified. (PAGE-29) 3. AC Characteristics modified. 4. Added 2Line 16 Chinese Word (32Com X 256Seg) application circuit. 5. Added oscillation resistor's relation to power consumption and frequency.
C2.0	2001/07/03	<ol style="list-style-type: none"> 1. Added Register initial values. 2. Voltage booster CAP1M CAP1P polarity changed. (PAGE-30)
V2.0	2001/08/17	<ol style="list-style-type: none"> 1. Modified Table 7. (PAGE-14) 2. Change to English version.
V2.0c	2001/10/18	<ol style="list-style-type: none"> 1. Modified page-38 Serial interface timing diagram
V2.0d	2002/05/09	<ol style="list-style-type: none"> 1. Add the standard code (Japan 、 GB code 、 BIG-5 code)
V3.0	2002/10/11	<ol style="list-style-type: none"> 1. Delete sleep mode function

Pads diagram

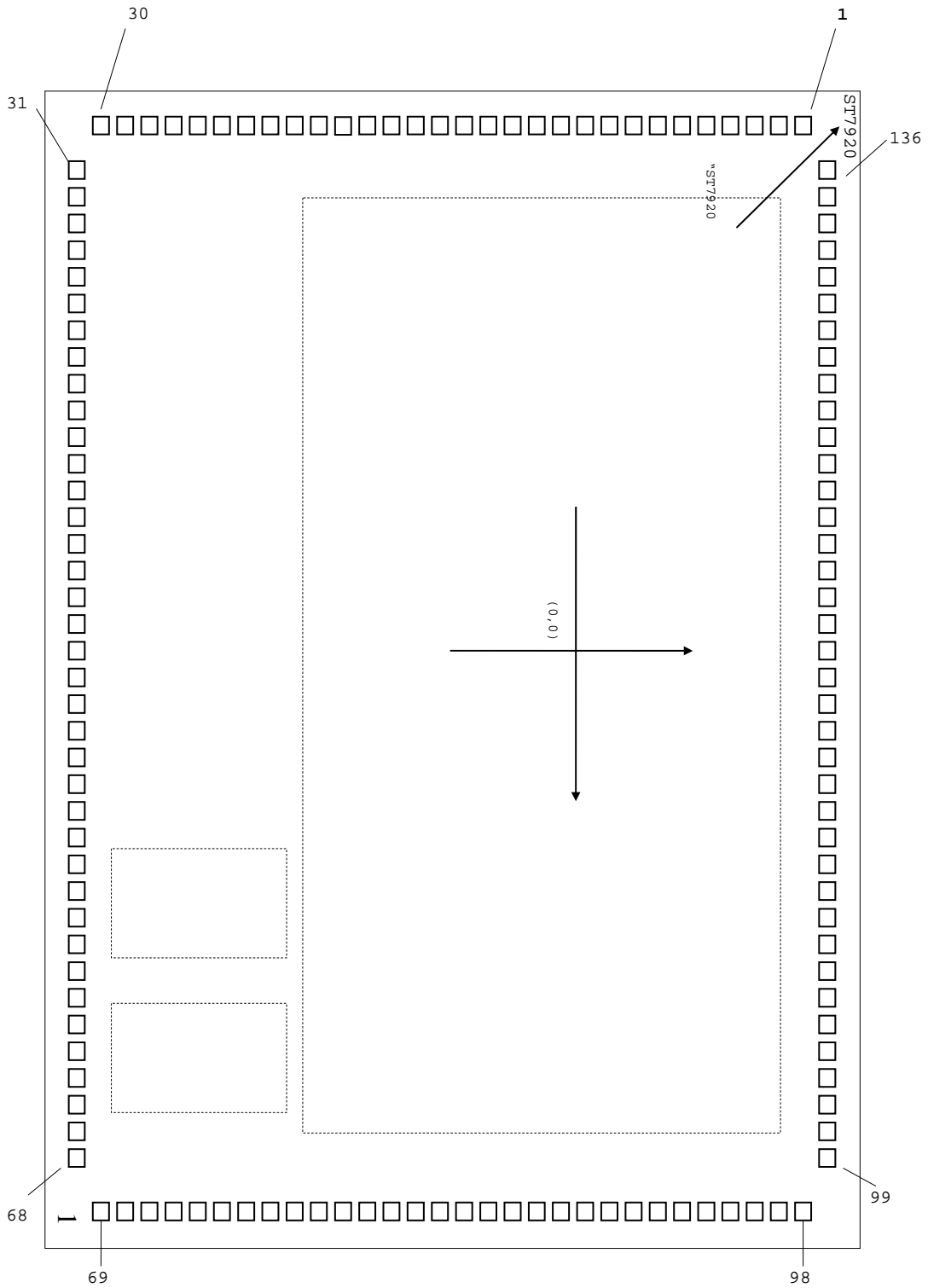

origin: center of chip coordinates: from pad center
 chip size: 5305 X 4074 Pad open: 90 X 90
 Pad pitch: 125 unit: μm

*** chip substrate must connect to VSS**

Pin coordinates

No.	Name	X	Y
1	V0	-2548	1812
2	V1	-2548	1688
3	V2	-2548	1562
4	N.C.	-2548	1438
5	N.C.	-2548	1312
6	N.C.	-2548	1188
7	V3	-2548	1062
8	V4	-2548	938
9	VSS	-2548	812
10	VDD	-2548	688
11	XRESET	-2548	562
12	CL1	-2548	438
13	CL2	-2548	312
14	VDD	-2548	188
15	M	-2548	62
16	DOUT	-2548	-62
17	RS	-2548	-188
18	RW	-2548	-312
19	E	-2548	-438
20	VSS	-2548	-562
21	OSC1	-2548	-688
22	OSC2	-2548	-812
23	PSB	-2548	-938
24	D0	-2548	-1062
25	D1	-2548	-1188
26	D2	-2548	-1312
27	D3	-2548	-1438
28	D4	-2548	-1562
29	D5	-2548	-1688
30	D6	-2548	-1812
31	D7	-2306	-1933
32	XOFF	-2181	-1933
33	VOUT	-2056	-1933
34	CAP3M	-1931	-1933
35	CAP1P	-1806	-1933
36	CAP1M	-1681	-1933
37	CAP2P	-1556	-1933
38	CAP2M	-1431	-1933

unit: um

No.	Name	X	Y
39	VD2	-1306	-1933
40	C[1]	-1181	-1933
41	C[2]	-1056	-1933
42	C[3]	-931	-1933
43	C[4]	-806	-1933
44	C[5]	-681	-1933
45	C[6]	-556	-1933
46	C[7]	-431	-1933
47	C[8]	-306	-1933
48	C[9]	-181	-1933
49	C[10]	-56	-1933
50	C[11]	69	-1933
51	C[12]	194	-1933
52	C[13]	319	-1933
53	C[14]	444	-1933
54	C[15]	569	-1933
55	C[16]	694	-1933
56	C[17]	819	-1933
57	C[18]	944	-1933
58	C[19]	1069	-1933
59	C[20]	1194	-1933
60	C[21]	1319	-1933
61	C[22]	1444	-1933
62	C[23]	1569	-1933
63	C[24]	1694	-1933
64	C[25]	1819	-1933
65	C[26]	1944	-1933
66	C[27]	2069	-1933
67	C[28]	2194	-1933
68	C[29]	2319	-1933
69	C[30]	2548	-1812
70	C[31]	2548	-1688
71	C[32]	2548	-1562
72	C[33]	2548	-1438
73	S[64]	2548	-1312
74	S[63]	2548	-1188
75	S[62]	2548	-1062
76	S[61]	2548	-938

No.	Name	X	Y
77	S[60]	2548	-812
78	S[59]	2548	-688
79	S[58]	2548	-562
80	S[57]	2548	-438
81	S[56]	2548	-312
82	S[55]	2548	-188
83	S[54]	2548	-62
84	S[53]	2548	62
85	S[52]	2548	188
86	S[51]	2548	312
87	S[50]	2548	438
88	S[49]	2548	562
89	S[48]	2548	688
90	S[47]	2548	812
91	S[46]	2548	938
92	S[45]	2548	1062
93	S[44]	2548	1188
94	S[43]	2548	1312
95	S[42]	2548	1438
96	S[41]	2548	1562
97	S[40]	2548	1688
98	S[39]	2548	1812
99	S[38]	2319	1933
100	S[37]	2194	1933
101	S[36]	2069	1933
102	S[35]	1944	1933
103	S[34]	1819	1933
104	S[33]	1694	1933
105	S[32]	1569	1933
106	S[31]	1444	1933
107	S[30]	1319	1933
108	S[29]	1194	1933
109	S[28]	1069	1933
110	S[27]	944	1933
111	S[26]	819	1933
112	S[25]	694	1933
113	S[24]	569	1933
114	S[23]	444	1933
115	S[22]	319	1933

No.	Name	X	Y
116	S[21]	194	1933
117	S[20]	69	1933
118	S[19]	-56	1933
119	S[18]	-181	1933
120	S[17]	-306	1933
121	S[16]	-431	1933
122	S[15]	-556	1933
123	S[14]	-681	1933
124	S[13]	-806	1933
125	S[12]	-931	1933
126	S[11]	-1056	1933
127	S[10]	-1181	1933
128	S[9]	-1306	1933
129	S[8]	-1431	1933
130	S[7]	-1556	1933
131	S[6]	-1681	1933
132	S[5]	-1806	1933
133	S[4]	-1931	1933
134	S[3]	-2056	1933
135	S[2]	-2181	1933
136	S[1]	-2306	1933

Pin Description

Name	No.	I/O	Connects to	Function
XRESET	11	I	—	System reset low active
PSB	23	I	—	Interface selection: 0: serial mode 1: 8/4-bits parallel bus mode
RS(CS*)	17	I	MPU	Register select 0: select instruction write, busy flag read, address counter read 1: select data write, read (Chip select) for serial mode 1: chip enable 0: chip disable
RW(SID*)	18	I	MPU	Read write control 0: write 1: read (serial data input)
E(SCLK*)	19	I	MPU	Enable trigger (serial clock)
D4 to D7	28~31	I/O	MPU	Higher nibble data bus for 8 bit interface and data bus for 4 bit interface
D0 to D3	24~27	I/O	MPU	Lower nibble data bus for 8 bit interface
CL1	12	O	Extension segment drv.	Latch signal for extension segment drivers
CL2	13	O	Extension segment drv.	Shift clock for extension segment drivers
M	15	O	Extension segment drv.	AC signal for extension segment drivers voltage inversion
DOUT	16	O	Extension segment drv.	Data output for extension segment drivers
COM1 to COM33	40~72	O	LCD	Common signals
SEG1 to SEG64	136~73	O	LCD	Segment signals
V0 to V4	1~3 7,8	—	—	LCD bias voltage $V_0 - V_4 \leq 7V$
V _{DD}	10,14	I	Power	V _{DD} : 2.7V to 5.5V
V _{SS}	9,20	I	Power	V _{SS} : 0V
OSC1, OSC2	21,22	I, O	Resistors	For internal oscillation resistor 5.0V R=33K 2.7V R=18K use OSC1 for external clock input
VOUT	33	O	Resistors	LCD voltage doubler output

***note:** The OSC pin must have the shortest wiring pattern of all other pins. To prevent noise from other signal lines, it should also be enclosed with the largest GND pattern possible. Poor noise characteristics on the OSC line will result in malfunction, or adversely affect the clock's duty ratio.

Pin description

Name	No.	I/O	Connects to	Description
CAP3M CAP1P CAP1M CAP2M	34 35 36 38	I/O	Capacitors	Capacitor pins for voltage doubler
XOFF	32	O	—	Reserved (no connection)
CAP2P	37	—	—	Reserved (no connection)
VD2	39	I	Reference voltage	Voltage doubler reference voltage
N.C. N.C. N.C.	4 5 6	I	— — —	Test pins (no connection)

Note:

1. $VDD \geq V0 \geq V1 \geq V2 \geq V3 \geq V4$ must be maintained
2. Two clock options:
3. When using voltage doubler for VOUT it is recommended that the total sum of bleeder resistors R1~R5 should be larger than 20K Ohm

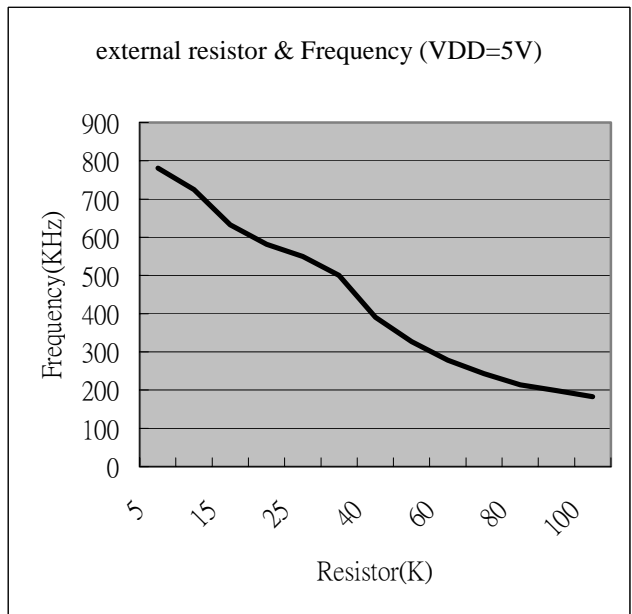
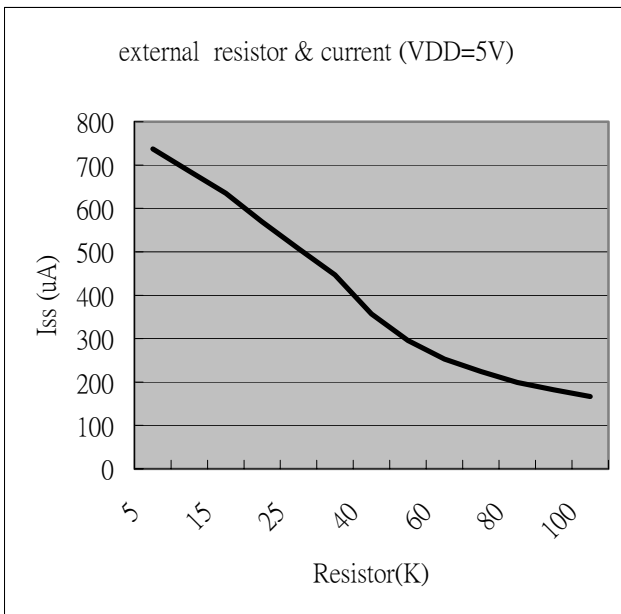
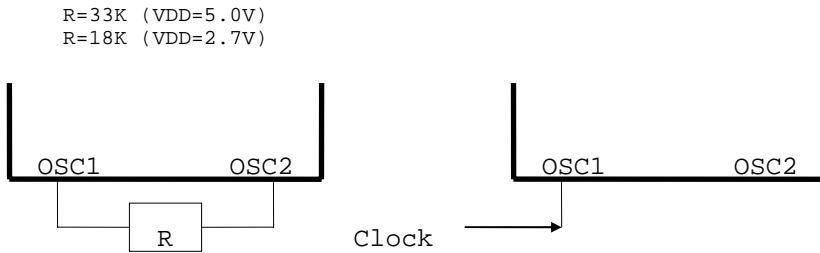

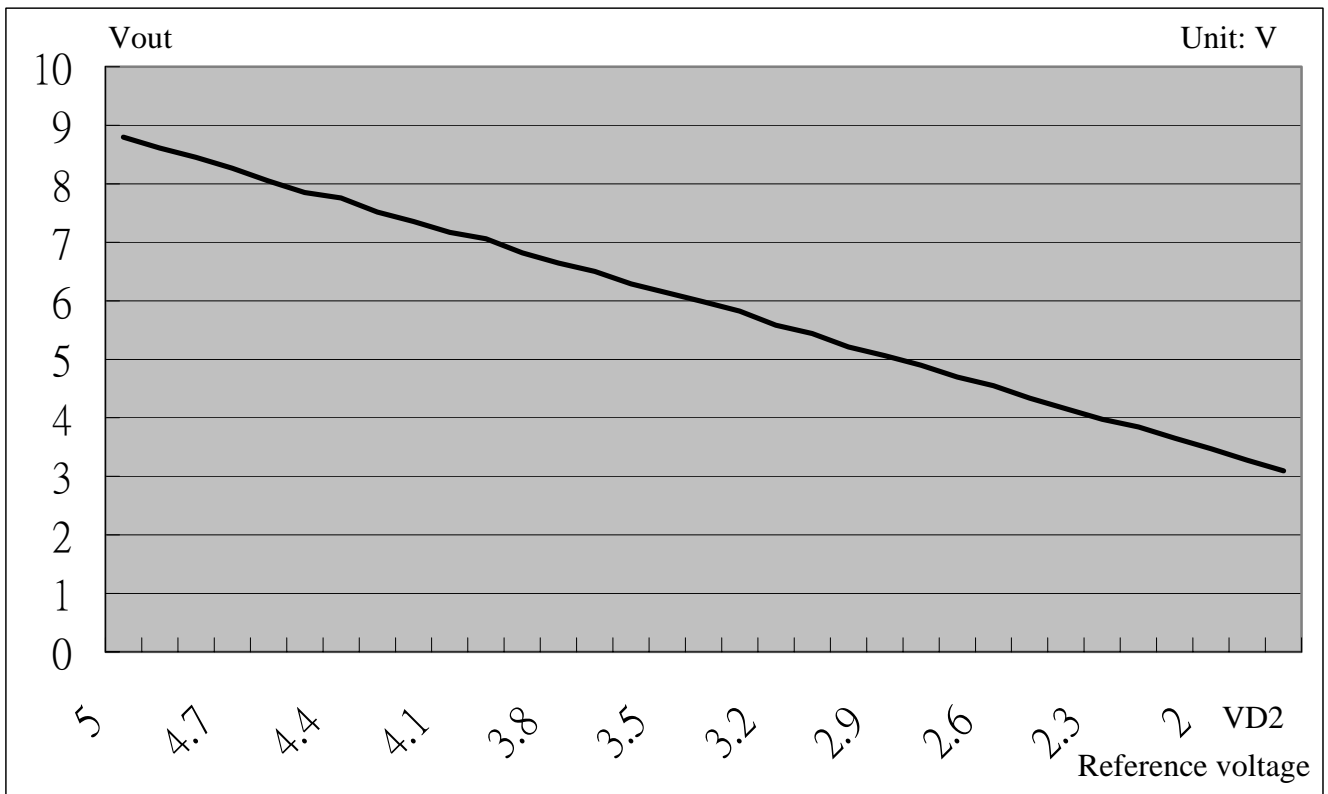
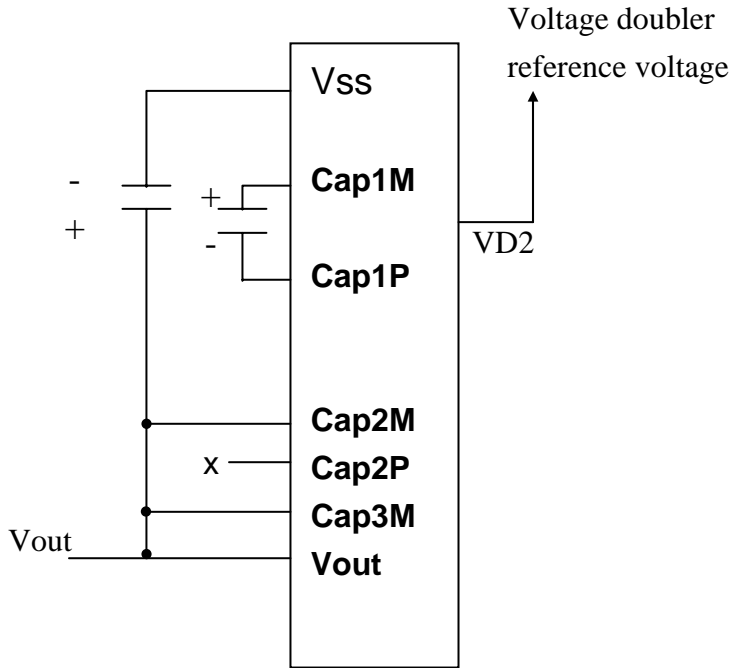

Doubler voltage mode VD2 & Vout output characteristic

Notes:

- Followler loading resistor total 20k(ohm)
- Boostaer Cap use 4.7uf
- Panel size 80mm * 28mm (check display)

Function Description :

System interface

ST7920 supports 3 kinds of bus interface to MPU. 8 bits parallel, 4 bits parallel and clock synchronized serial interface. Parallel interface is selected by PSB="1" and serial interface by PSB="0". 8 bit / 4 bit interface is selected by function set instruction DL bit.

Two 8 bit registers (data register DR, instruction register IR) are used in ST7920's write and read operation. Data Register (DR) can access DDRAM/CGRAM/GDRAM and IRAM's data through the address pointer implemented by Address Counter (AC). Instruction Register (IR) stores the instruction by MPU to ST7920.

4 modes of read/write operation specified by RS and RW :

RS	RW	description
L	L	MPU write instruction to instruction register (IR)
L	H	MPU read busy flag (BF) and address counter (AC)
H	L	MPU write data to data register (DR)
H	H	MPU read data from data register (DR)

Busy Flag (BF)

Internal operation is in progress when BF="1", ST7920 is in busy state. No new instruction will be accepted until BF="0". MPU must check BF to determine whether the internal operation is finished and new instruction can be sent.

Address counter (AC)

Address counter (AC) is used for address pointer of DDRAM/CGRAM/IRAM/GDRAM. (AC) can be set by instruction and after data read or write to the memories (AC) will increase or decrease by 1 according to the setting in "entry mode set". When RS= "0" and RW= "1" and E="1" the value of (AC) will output to DB6~DB0.

16x16 character generation ROM (CGROM) and 8x16 half height ROM (HCGROM)

ST7920 provides character generation ROM supporting 8192 16 x 16 character fonts and 126 8 x 16 alphanumeric characters. It is easy to support multi languages application such as Chinese and English. Two consecutive bytes are used to specify one 16x16 character or two 8x16 half-height characters. Character codes are written into DDRAM and the corresponding fonts are mapped from CGROM or HCGROM to the display drivers.

Character generation RAM (CGRAM)

ST7920 provides RAM to support user-defined fonts. Four sets of 16x16 bit map area are available. These user-defined fonts are displayed the same ways as CGROM fonts through writing character cod data to DDRAM.

ICON RAM (IRAM)

ST7920 provides 240 ICON display. It consists of 15 sets of IRAM address. Each IRAM address has 16 bits data. IRAM address should be set first before writing to the IRAM. Two bytes for each address. First higher byte (D15~D8) and then lower byte (D7~D0).

Display data RAM (DDRAM)

There are 64x2 bytes for display data RAM area. Can store display data for 16 characters(16x16) by 4 lines or 32 characters(8x16) by 4 lines. However, only 2 lines can be displayed at a time. Character codes stored in DDRAM point to the fonts specified by CGROM · HCGROM and CGRAM. ST7920 display half height HCGROM fonts, user-defined CGRAM fonts and full 16x16 CGROM fonts. Data codes 0000H~0006H are for CGRAM user-defined fonts. Data codes 02H~7FH are for half height alpha numeric fonts. Data codes (A140~D75F) are for BIG5 code and (A1A0~F7FF) are for GB code.

1. display HCGROM fonts : Write 2 bytes data to DDRAM to display two 8x16 fonts. Each byte represents 1 character font. The data of each byte is 02H~7FH.
2. display CGRAM fonts : Write 2 bytes data to DDRAM to display one 16x16 font. Only 0000H · 0002H · 0004H · 0006H are allowed.
3. display CGROM fonts : Write 2 bytes data to DDRAM to display one 16x16 font.
A140H~D75FH are for (BIG5) code, A1A0H~F7FFH are for (GB) code.

Higher byte (D15~D8) are written first and then lower byte (D7~D0) .

Refer to Table 5 for address map

CGRAM fonts and CGROM fonts can only be displayed in the start position of each address. (Refer toTable 4)

80		81		82		83		84		85		86		87		88		89		8A		8B		8C		8D		8E		8F			
H	L	H	L	H	L	H	L	H	L	H	L	H	L	H	L	H	L	H	L	H	L	H	L	H	L	H	L	H	L	H	L	H	L
S	i	t	r	o	n	i	x	.	.	S	T	7	9	2	0																		
矽	創	電	子	中	文	編	碼							(正	確)												
矽	創	電	子	中	文	編	碼																						

Table 4

Incorrect position

Graphic RAM (GDRAM)

Graphic display RAM supports 64x256 bits bit-mapped memory space. GDRAM address is set by writing 2 consecutive bytes for vertical address and horizontal address. Two-bytes data write to GDRAM for one address. Address counter will automatically increase by one for the next two-byte data. The procedure is as followings.

1. Set vertical address (Y) for GDRAM
2. Set horizontal address (X) for GDRAM
3. Write D15~D8 to GDRAM 中(first byte)
4. Write D7~D0 to GDRAM 中(second byte)

Graphic display memory map please refer to Table-8

LCD driver

LCD driver have 33 common and 64 segments to drive the LCD panel. Segment data from CGRAM /CGROM /HCGROM are shifted into the 64 bits segment latches to display. Extended segment driver ST7921 can be used to extend the segment drivers to 256.

DDRAM data (char. code)				CGRAM Addr.				CGRAM data (higher byte)				CGRAM data (lower byte)																			
B15~ B4	B3	B2	B1	B0	B5	B4	B3	B2	B1	B0	D15	D14	D13	D12	D11	D10	D9	D8	D7	D6	D5	D4	D3	D2	D1	D0					
0	X	00	X	00	0	0	0	0	0	0	0	0	0	0	1	0	0	0	0	0	1	1	0	0	0	0	0				
					0	0	0	1	1	1	1	1	1	1	0	0	1	0	0	0	0	0	0	1	0	0	0	0	0	0	
					0	0	1	0	0	0	0	1	0	0	0	0	0	0	1	0	0	0	0	0	1	0	0	0	1	0	0
					0	0	1	1	0	0	0	1	0	0	0	0	0	0	1	1	1	1	1	0	1	1	1	1	1	1	0
					0	1	0	0	0	0	1	0	0	1	0	0	1	0	0	1	0	0	1	0	0	0	0	0	1	0	0
					0	1	0	1	0	0	1	1	1	1	0	0	1	0	0	1	0	0	1	0	0	0	0	0	1	0	0
					0	1	1	0	0	1	1	0	0	1	0	1	0	1	0	1	0	1	0	0	1	0	0	1	0	0	0
					0	1	1	1	1	0	0	0	1	0	0	1	0	0	1	1	0	0	1	0	0	1	0	0	1	0	0
					1	0	0	0	0	0	1	0	0	1	0	0	1	0	0	1	0	0	0	1	0	1	0	0	0	0	0
					1	0	0	1	0	0	1	0	0	1	0	0	1	0	0	1	0	0	0	0	1	0	0	0	0	0	0
					1	0	1	0	0	0	1	0	0	1	0	0	1	0	0	1	0	0	0	0	1	0	0	0	0	0	0
					1	0	1	1	0	0	1	1	1	1	0	0	0	0	1	1	1	0	0	0	1	0	0	0	0	0	0
					1	1	0	0	0	0	1	0	0	1	0	0	1	0	0	1	0	0	0	1	0	0	0	0	0	0	0
					1	1	0	1	0	0	0	0	0	0	0	0	0	0	0	0	0	0	0	1	0	0	0	0	0	0	0
					1	1	1	0	0	0	0	0	0	0	0	0	0	0	0	0	0	0	0	0	0	0	0	0	0	0	0

Table 5 : DDRAM data (character code) , CGRAM data / address map

Note :

1. DDRAM data (character code) bit1 and bit2 are the same as CGRAM address bit4 and bit5.
2. CGRAM address bit0 to bit3 specify total 16 rows. Row16 is for cursor display. The data in row 16 will be logical OR to the cursor.
3. CGRAM data for each address is 16 bits.
4. DDRAM data to select CGRAM bit4 to bit15 must be "0". Bit0 and bit3 value are "don't care".

ICON RAM address Set SR "0", and then set IRAM address AC3....AC0				ICON RAM data															
				Higher byte								Lower byte							
AC3	AC2	AC1	AC0	D15	D14	D13	D12	D11	D10	D9	D8	D7	D6	D5	D4	D3	D2	D1	D0
0	0	0	0	SEG0	SEG1	SEG2	SEG3	SEG4	SEG5	SEG6	SEG7	SEG8	SEG9	SEG10	SEG11	SEG12	SEG13	SEG14	SEG15
0	0	0	1	SEG16	SEG17	SEG18	SEG19	SEG20	SEG21	SEG22	SEG23	SEG24	SEG25	SEG26	SEG27	SEG28	SEG29	SEG30	SEG31
0	0	1	0	SEG32	SEG33	SEG34	SEG35	SEG36	SEG37	SEG38	SEG39	SEG40	SEG41	SEG42	SEG43	SEG44	SEG45	SEG46	SEG47
0	0	1	1	SEG48	SEG49	SEG50	SEG51	SEG52	SEG53	SEG54	SEG55	SEG56	SEG57	SEG58	SEG59	SEG60	SEG61	SEG62	SEG63
0	1	0	0	SEG64	SEG65	SEG66	SEG67	SEG68	SEG69	SEG70	SEG71	SEG72	SEG73	SEG74	SEG75	SEG76	SEG77	SEG78	SEG79
0	1	0	1	SEG80	SEG81	SEG82	SEG83	SEG84	SEG85	SEG86	SEG87	SEG88	SEG89	SEG90	SEG91	SEG92	SEG93	SEG94	SEG95
0	1	1	0	SEG96	SEG97	SEG98	SEG99	SEG100	SEG101	SEG102	SEG103	SEG104	SEG105	SEG106	SEG107	SEG108	SEG109	SEG110	SEG111
0	1	1	1	SEG112	SEG113	SEG114	SEG115	SEG116	SEG117	SEG118	SEG119	SEG120	SEG121	SEG122	SEG123	SEG124	SEG125	SEG126	SEG127
1	0	0	0	SEG128	SEG129	SEG130	SEG131	SEG132	SEG133	SEG134	SEG135	SEG136	SEG137	SEG138	SEG139	SEG140	SEG141	SEG142	SEG143
1	0	0	1	SEG144	SEG145	SEG146	SEG147	SEG148	SEG149	SEG150	SEG151	SEG152	SEG153	SEG154	SEG155	SEG156	SEG157	SEG158	SEG159
1	0	1	0	SEG160	SEG161	SEG162	SEG163	SEG164	SEG165	SEG166	SEG167	SEG168	SEG169	SEG170	SEG171	SEG172	SEG173	SEG174	SEG175
1	0	1	1	SEG176	SEG177	SEG178	SEG179	SEG180	SEG181	SEG182	SEG183	SEG184	SEG185	SEG186	SEG187	SEG188	SEG189	SEG190	SEG191
1	1	0	0	SEG192	SEG193	SEG194	SEG195	SEG196	SEG197	SEG198	SEG199	SEG200	SEG201	SEG202	SEG203	SEG204	SEG205	SEG206	SEG207
1	1	0	1	SEG208	SEG209	SEG210	SEG211	SEG212	SEG213	SEG214	SEG215	SEG216	SEG217	SEG218	SEG219	SEG220	SEG221	SEG222	SEG223
1	1	1	0	SEG224	SEG225	SEG226	SEG227	SEG228	SEG229	SEG230	SEG231	SEG232	SEG233	SEG234	SEG235	SEG236	SEG237	SEG238	SEG239
1	1	1	1	---	---	---	---	---	---	---	---	---	---	---	---	---	---	---	---

Table 6 ICON RAM address, data and Segment pins

H/L	0	1	2	3	4	5	6	7	8	9	A	B	C	D	E	F
0																
1																
2																
3																
4																
5																
6																
7														<td></td> <td></td>		

Table 7 16x8 half-height characters

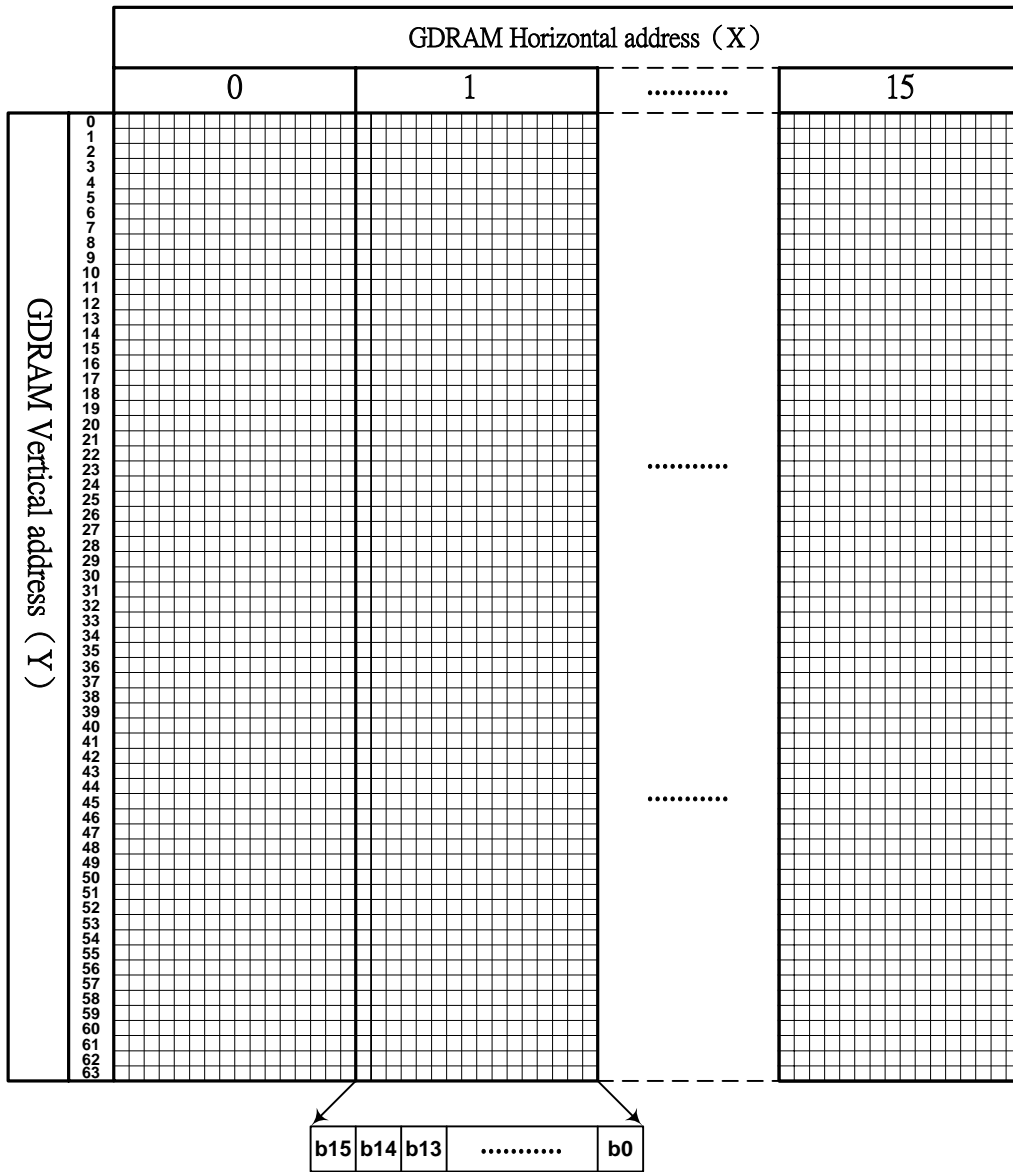

Table 8 GDRAM display coordinates and corresponding address

Instructions

ST7920 offers basic instruction set and extended instruction set :

Instruction set 1: (RE=0: basic instruction)

Ins	code										Description	Exec time (540KHZ)
	RS	RW	DB7	DB6	DB5	DB4	DB3	DB2	DB1	DB0		
CLEAR	0	0	0	0	0	0	0	0	0	1	Fill DDRAM with "20H", and set DDRAM address counter (AC) to "00H"	1.6 ms
HOME	0	0	0	0	0	0	0	0	0	1 X	Set DDRAM address counter (AC) to "00H", and put cursor to origin ; the content of DDRAM are not changed	72us
ENTRY MODE	0	0	0	0	0	0	0	0	1	I/D S	Set cursor position and display shift when doing write or read operation	72us
DISPLAY ON/OFF	0	0	0	0	0	0	1	D	C	B	D=1: display ON C=1: cursor ON B=1: blink ON	72 us
CURSOR DISPLAY CONTROL	0	0	0	0	0	1	S/C	R/L	X	X	Cursor position and display shift control ; the content of DDRAM are not changed	72 us
FUNCTION SET	0	0	0	0	1	DL	X	0 RE	X	X	DL=1 8-BIT interface DL=0 4-BIT interface <u>RE=1: extended instruction</u> <u>RE=0: basic instruction</u>	72 us
SET CGRAM ADDR.	0	0	0	1	AC5	AC4	AC3	AC2	AC1	AC0	Set CGRAM address to address counter (AC) <u>Make sure that in extended instruction SR=0 (scroll or RAM address select)</u>	72 us
SET DDRAM ADDR.	0	0	1	0 AC6	AC5	AC4	AC3	AC2	AC1	AC0	Set DDRAM address to address counter (AC) AC6 is fixed to 0	72 us
READ BUSY FLAG (BF) & ADDR.	0	1	BF	AC6	AC5	AC4	AC3	AC2	AC1	AC0	Read busy flag (BF) for completion of internal operation, also Read out the value of address counter (AC)	0 us
WRITE RAM	1	0	D7	D6	D5	D4	D3	D2	D1	D0	Write data to internal RAM (DDRAM/CGRAM/IRAM/GDRAM)	72 us
READ RAM	1	1	D7	D6	D5	D4	D3	D2	D1	D0	Read data from internal RAM (DDRAM/CGRAM/IRAM/GDRAM)	72 us

Instruction set 2: (RE=1: extended instruction)

Inst.	code										description	Exec. time (540KHZ)
	RS	RW	DB7	DB6	DB5	DB4	DB3	DB2	DB1	DB0		
STAND BY	0	0	0	0	0	0	0	0	0	1	Enter stand by mode, any other instruction can terminate (Com1..32 halted, only Com33 ICON can display)	72 us
SCROLL or RAM ADDR. SELECT	0	0	0	0	0	0	0	0	0	1	SR SR=1: enable vertical scroll position SR=0: enable IRAM address (extended instruction) SR=0: enable CGRAM address(basic instruction)	72 us
REVERSE	0	0	0	0	0	0	0	0	1	R1	R0 Select 1 out of 4 line (in DDRAM) and decide whether to reverse the display by toggling this instruction R1,R0 initial value is 00	72 us
EXTENDED FUNCTION SET	0	0	0	0	1	DL	X	1	RE	G	0 DL=1 8-BIT interface DL=0 4-BIT interface RE=1: extended instruction set RE=0: basic instruction set G=1 :graphic display ON G=0 :graphic display OFF	72 us
SET IRAM or SCROLL ADDR	0	0	0	1	AC5	AC4	AC3	AC2	AC1	AC0	SR=1: AC5~AC0 the address of vertical scroll SR=0: AC3~AC0 the address of ICON RAM	72 us
SET GRAPHIC RAM ADDR.	0	0	1	0	0	0	AC3	AC2	AC1	AC0	Set GDRAM address to address counter (AC) First set vertical address and the horizontal address by consecutive writing Vertical address range AC6...AC0 Horizontal address range AC3...AC0	72 us

Note :

1. Make sure that ST7920 is not in busy state by reading the busy flag before sending instruction or data. If use delay loop instead please make sure the delay time is enough. Please refer to the instruction execution time.
2. "RE" is the selection bit of basic and extended instruction set. Each time when altering the value of RE it will remain. There is no need to set RE every time when using the same group of instruction set.

Initial setting(Register flag) (RE=0: basic instruction)

Inst.	code										Description
	RS	RW	DB7	DB6	DB5	DB4	DB3	DB2	DB1	DB0	
ENTRY MODE SET	0	0	0	0	0	0	0	1	I/D	S	Cursor move to right ,DDRAM address counter (AC) plus 1
									1	0	
DISPLAY STATUS	0	0	0	0	0	0	1	D	C	B	Display, cursor and blink ALL OFF
								0	0	0	
CURSOR DISPLAY SHIFT	0	0	0	0	0	1	S/C	R/L	X	X	No cursor or display shift operation
							X	X			
FUNCTION SET	0	0	0	0	1	DL	X	0 RE	X	X	8 BIT MPU interface , basic instruction set
					1			0			

Initial setting(Register flag) (RE=1: extended instruction set)

Inst.	code										description
	RS	RW	DB7	DB6	DB5	DB4	DB3	DB2	DB1	DB0	
SCROLL OR RAM ADDR. SELECT	0	0	0	0	0	0	0	0	1	SR	Allow IRAMaddress or set CGRAM address
										0	
REVERSE	0	0	0	0	0	0	0	1	R1	R0	Begin with normal and toggle to reverse
									0	0	
EXTENDED FUNCTION SET	0	0	0	0	1	DL	X	1 RE	G	0	Graphic display OFF
									0		

Description of basic instruction set

- **CLEAR**

	RS	RW	DB7	DB6	DB5	DB4	DB3	DB2	DB1	DB0
Code	0	0	0	0	0	0	0	0	0	1

Fill DDRAM with "20H"(space code). And set DDRAM address counter (AC) to "00H". Set entry mode I/D bit to be "1".
 Cursor moves right and AC adds 1 after write or read operation.

- **HOME**

	RS	RW	DB7	DB6	DB5	DB4	DB3	DB2	DB1	DB0
Code	0	0	0	0	0	0	0	0	1	x

Set DDRAM address counter (AC) to "00H". Cursor moves to origin. Then content of DDRAM is not changed.

- **ENTRY MODE SET**

	RS	RW	DB7	DB6	DB5	DB4	DB3	DB2	DB1	DB0
Code	0	0	0	0	0	0	0	1	I/D	S

Set the cursor movement and display shift direction when doing write or read operation.

I/D :address counter increase / decrease

When I/D = "1", cursor moves right, DRAM address counter (AC) add by 1.

When I/D = "0", cursor moves left, DRAM address counter (AC) subtract by 1.

S: Display shift

S	I/D	DESCRIPTION
H	H	Entire display shift left by 1
H	L	Entire display shift right by 1

● **DISPLAY STATUS**

	RS	RW	DB7	DB6	DB5	DB4	DB3	DB2	DB1	DB0
Code	0	0	0	0	0	0	1	D	C	B

Controls display, cursor and blink ON/OFF.

D : Display ON/OFF control bit

When D = "1", display ON

When D = "0", display OFF, the content of DDRAM is not changed

C : Cursor ON/OFF control bit

When C = "1", cursor ON.

When C = "0", cursor OFF.

B : Blink ON/OFF control bit

When B = "1", cursor position blink ON. Then display data in cursor position will blink.

When B = "0", cursor position blink OFF

● **CURSOR AND DISPLAY SHIFT CONTROL**

	RS	RW	DB7	DB6	DB5	DB4	DB3	DB2	DB1	DB0
Code	0	0	0	0	0	1	S/C	R/L	x	x

Instruction to move the cursor or shift the entire display. The content of DDRAM is not changed.

S/C	R/L	Description	AC Value
L	L	Cursor moves left by 1	AC=AC-1
L	H	Cursor moves right by 1	AC=AC+1
H	L	Display shift left by 1, cursor also follows to shift.	AC=AC
H	H	Display shift right by 1, cursor also follows to shift.	AC=AC

● **FUNCTION SET**

	RS	RW	DB7	DB6	DB5	DB4	DB3	DB2	DB1	DB0
Code	0	0	0	0	1	DL	X	RE	x	x

DL : 4/8 BIT interface control bit

When DL = "1", **8 BIT** MPU bus interface

When DL = "0", 爲 **4 BIT** MPU bus interface

RE : extended instruction set control bit

When RE = "1", extended instruction set

When RE = "0", basic instruction set

In same instruction cannot alter DL and RE at once. Make sure that change DL first then RE.

● **SET CGRAM ADDRESS**

	RS	RW	DB7	DB6	DB5	DB4	DB3	DB2	DB1	DB0
Code	0	0	0	1	AC5	AC4	AC3	AC2	AC1	AC0

Set CGRAM address to address counter (AC)

AC range is 00H..3FH

Make sure that in extended instruction SR=0 (scroll address or RAM address select)

● **SET DDRAM ADDRESS**

	RS	RW	DB7	DB6	DB5	DB4	DB3	DB2	DB1	DB0
Code	0	0	1	AC6	AC5	AC4	AC3	AC2	AC1	AC0

Set DDRAM address to address counter (AC) .

First line AC range is 80H..8FH

Second line AC range is 90H..9FH

Third line AC range is A0H..AFH

Fourth line AC range is B0H..BFH

Please note that only 2 lines can be display at a time.

● **READ BUSY FLAG (BF) AND ADDRESS**

	RS	RW	DB7	DB6	DB5	DB4	DB3	DB2	DB1	DB0
Code	0	1	BF	AC6	AC5	AC4	AC3	AC2	AC1	AC0

Read busy flag (BF) can check whether internal operation is finished. At the same time the value of address counter

(AC) is also read. When BF = "1" new instruction will not be accepted. Must wait for BF = "0" for new instruction.

● **WRITE DATA TO RAM**

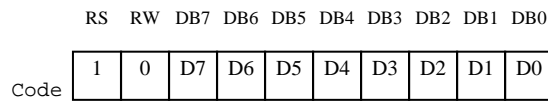

Write data to internal RAM and alter the (AC) by 1

Each RAM address (CGRAM,DDRAM,IRAM.....) must write 2 consecutive bytes for 16 bit data. After the second byte the address counter will add or subtract by 1 according to the entry mode set control bit.

● **READ RAM DATA**

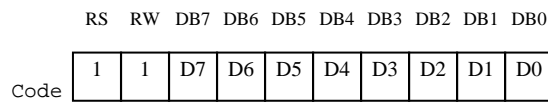

Read data from internal RAM and alter the (AC) by 1

After address set to read (CGRAM,DDRAM,IRAM.....)a DUMMY READ is required.

There is no need to DUMMY READ for the following bytes unless a new address set instruction is issued.

Description of extended instruction set

- **STAND BY**

	RS	RW	DB7	DB6	DB5	DB4	DB3	DB2	DB1	DB0
Code	0	0	0	0	0	0	0	0	0	1

Instruction to enter stand by mode. Any other instruction follows this instruction can terminate stand by.
The content of DDRAM remain the same.

- **VERTICAL SCROLL OR RAM ADDRESS SELECT**

	RS	RW	DB7	DB6	DB5	DB4	DB3	DB2	DB1	DB0
Code	0	0	0	0	0	0	0	0	1	SR

When SR = "1", the vertical scroll address set is enabled.

When SR = "0", the IRAM address set (**extended instruction**) and CGRAM address set(**basic instruction**) is enabled.

- **REVERSE**

	RS	RW	DB7	DB6	DB5	DB4	DB3	DB2	DB1	DB0
Code	0	0	0	0	0	0	0	1	R1	R0

Select 1 out of 4 lines to reverse the display and to toggle the reverse condition by repeating this instruction.

R1,R0 initial vale is 00. When set the first time the display is reversed and set the second time the display become normal.

R1	R0	Description
L	L	First line normal or reverse
L	H	Second line normal or reverse
H	L	Third line normal or reverse
H	H	Fourth line normal or reverse

Please note that only 2 lines out of 4 line display data can be displayed.

● **EXTENDED FUNCTION SET**

	RS	RW	DB7	DB6	DB5	DB4	DB3	DB2	DB1	DB0
Code	0	0	0	0	1	DL	x	RE	G	x

DL : 4/8 BIT interface control bit

When DL = "1", **8 BIT** MPU interface

When DL = "0", **4 BIT** MPU interface

RE : extended instruction set control bit

When RE = "1", extended instruction set

When RE = "0", basic instruction set

G : Graphic display control bit

When G = "1", graphic display ON

When G = "0", Graphic display OFF

In same instruction cannot alter DL, RE and G at once. Make sure that change DL or G first and then RE.

● **SET IRAM OR SCROLL ADDRESS**

	RS	RW	DB7	DB6	DB5	DB4	DB3	DB2	DB1	DB0
Code	0	0	0	1	AC5	AC4	AC3	AC2	AC1	AC0

SR=1: AC5~AC0 is vertical scroll displacement address

SR=0: AC3~AC0 is ICON RAM address

● **SET GRAPHIC RAM ADDRESS**

	RS	RW	DB7	DB6	DB5	DB4	DB3	DB2	DB1	DB0
Code	0	0	1	AC6	AC5	AC4	AC3	AC2	AC1	AC0

Set GDRAM address to address counter (AC) .

First set vertical address and then horizontal address(write 2 consecutive bytes to complete vertical and horizontal address set)

Vertical address range is AC6...AC0

Horizontal address range is AC3...AC0

The address counter (AC) of graphic RAM(GRAM) only increment after write for horizontal address. After horizontal address =0FH it will automatically back to 00H. However, the vertical address will not increase as the result of the same action.

Parallel interface :

ST7920 is in parallel mode by pulling up PSB pin. And can select 8 bit or 4-bit bus interface by function set instruction DL control bit. MPU can control (RS , RW , E , and DB0..DB7) pins to complete the data transmission.

In 4-bit transfer mode, every 8 bits data or instruction is separated into 2 parts. Higher 4 bits (DB7~DB4) data will transfer first and placed into data pins (DB7~DB4) . Lower 4 bits (DB3~DB0) data will transfer second and placed into data pins (DB7~DB4) . (DB3~DB0) data pins are not used.

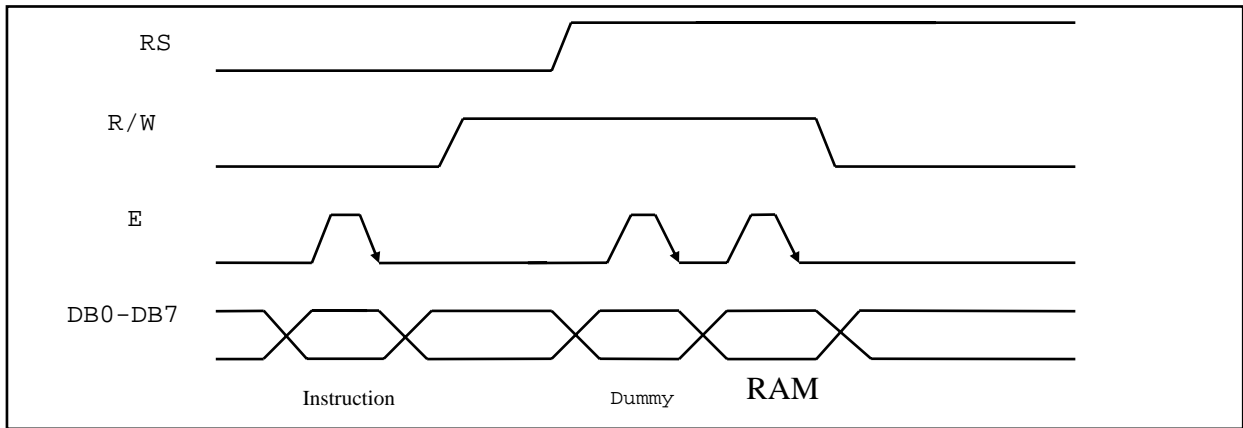

Timing Diagram of 8-bit Parallel Bus Mode Data Transfer

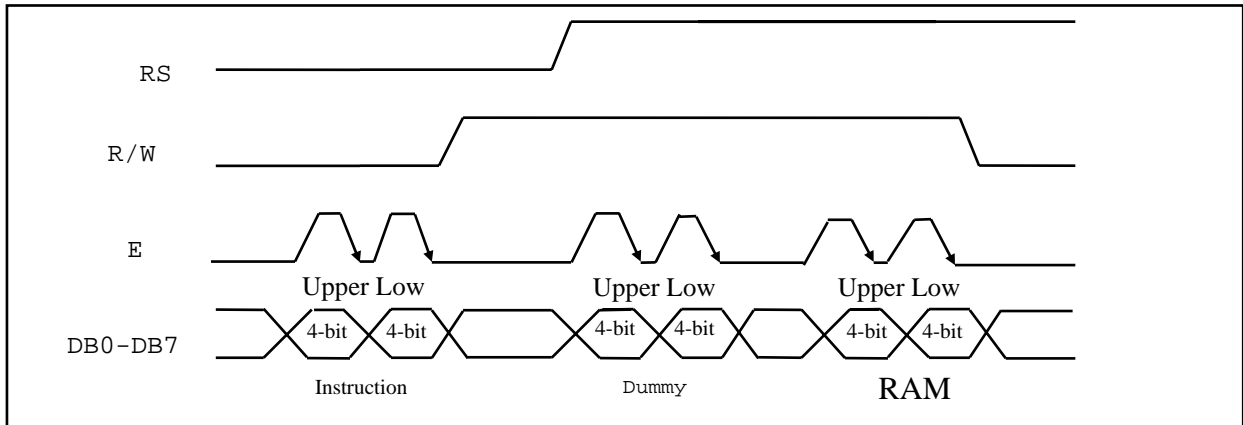

Timing Diagram of 4-bit Parallel Bus Mode Data Transfer

Serial interface :

ST7920 is in serial interface mode when pull down PSB pin. Two pins (SCLK and SID) are used to complete the data transfer. Only write data is available.

When connecting several ST7920, chip select (CS) must be used. Only when (CS) is high the serial clock (SCLK) can be accepted. On the other hand, when chip select (CS) is low ST7920 serial counter and data will be reset. Transmission will be terminated and data will be cleared. Serial transfer counter is set to the first bit. For a minimal system with only one ST7920 and one MPU, only SCLK and SID pins are necessary. CS pin should pull to high.

ST7920's serial clock(SCLK)is asynchronous to the internal clock and is generated by MPU. When multiple instruction/data is transferred instruction execution time must be considered. Must wait for the previous instruction to finish before sending the next. ST7920 has no internal instruction buffer area.

When starting a transmission a start byte is required. It consists of 5 consecutive "1" (sync character) . Serial transfer counter will be reset and synchronized. Following 2 bits for read/write(RW)and register/data select(RS). Last 4 bits is filled by "0" .

After receiving the sync character and RW and RS bits, every 8 bits instruction/data will be separated into 2 groups. Higher 4 bits (DB7~DB4) will be placed in first section followed by 4 "0" . And lower 4 bits (DB3~DB0) will be placed in second section followed by 4 "0" .

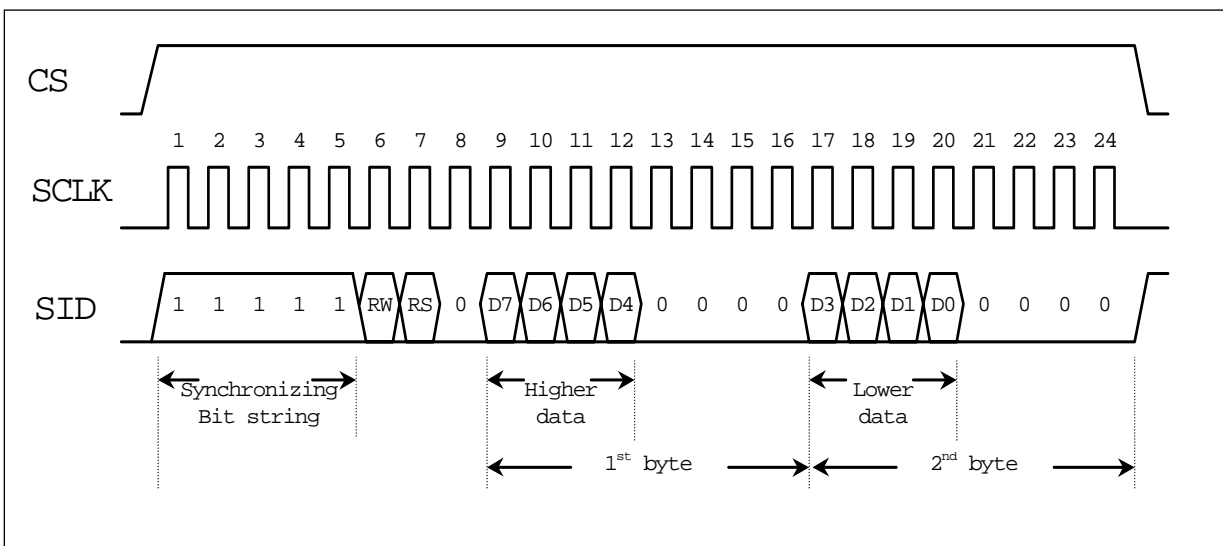

Timing Diagram of Serial Mode Data Transfer

8051 demo program for serial interface

```

;-----
; Write data from A into INSTRUCTION Register
;-----

```

WRINS:

```

SETB CS
SETB SID ; SID = 1
CLR SCLK
SETB SCLK ; READ DATA FROM SID
CLR SCLK
SETB SCLK ; READ DATA FROM SID
CLR SCLK
SETB SCLK ; READ DATA FROM SID
CLR SCLK
SETB SCLK ; READ DATA FROM SID
CLR SCLK
SETB SCLK ; READ DATA FROM SID
CLR SCLK
SETB SCLK ; READ DATA FROM SID
CLR SCLK
SETB SCLK ; READ DATA FROM SID
CLR SCLK
MOVBIT SID, A.7 ; SID = A.7
SETB SCLK ; READ DATA FROM SID
CLR SCLK
MOVBIT SID, A.6 ; SID = A.6
SETB SCLK ; READ DATA FROM SID
CLR SCLK
MOVBIT SID, A.5 ; SID = A.5
SETB SCLK ; READ DATA FROM SID
CLR SCLK
MOVBIT SID, A.4 ; SID = A.4
SETB SCLK ; READ DATA FROM SID
CLR SCLK
CLR SID ; SID = 0
SETB SCLK ; READ DATA FROM SID
CLR SCLK
SETB SCLK ; READ DATA FROM SID
CLR SCLK
SETB SCLK ; READ DATA FROM SID
CLR SCLK
SETB SCLK ; READ DATA FROM SID
CLR SCLK
MOVBIT SID, A.3 ; SID = A.3
SETB SCLK ; READ DATA FROM SID
CLR SCLK
MOVBIT SID, A.2 ; SID = A.2
SETB SCLK ; READ DATA FROM SID
CLR SCLK
MOVBIT SID, A.1 ; SID = A.1
SETB SCLK ; READ DATA FROM SID
CLR SCLK
MOVBIT SID, A.0 ; SID = A.0
SETB SCLK ; READ DATA FROM SID
CLR SCLK
CLR SID ; SID = 0
SETB SCLK ; READ DATA FROM SID
CLR SCLK
SETB SCLK ; READ DATA FROM SID
CLR SCLK
SETB SCLK ; READ DATA FROM SID
CLR SCLK
SETB SCLK ; READ DATA FROM SID
CLR SCLK
CALL DLY8
RET

```

```

;-----
; Write data from A into DATA Register
;-----

```

WRDATA:

```

SETB CS
SETB SID ; SID = 1
CLR SCLK
SETB SCLK ; READ DATA FROM SID
CLR SCLK
SETB SCLK ; READ DATA FROM SID
CLR SCLK
SETB SCLK ; READ DATA FROM SID
CLR SCLK
SETB SCLK ; READ DATA FROM SID
CLR SCLK
SETB SCLK ; READ DATA FROM SID
CLR SCLK
SETB SCLK ; READ DATA FROM SID
CLR SCLK
SETB SCLK ; READ DATA FROM SID
CLR SCLK
SETB SCLK ; READ DATA FROM SID
CLR SCLK
MOVBIT SID, A.7 ; SID = A.7
SETB SCLK ; READ DATA FROM SID
CLR SCLK
MOVBIT SID, A.6 ; SID = A.6
SETB SCLK ; READ DATA FROM SID
CLR SCLK
MOVBIT SID, A.5 ; SID = A.5
SETB SCLK ; READ DATA FROM SID
CLR SCLK
MOVBIT SID, A.4 ; SID = A.4
SETB SCLK ; READ DATA FROM SID
CLR SCLK
CLR SID ; SID = 0
SETB SCLK ; READ DATA FROM SID
CLR SCLK
SETB SCLK ; READ DATA FROM SID
CLR SCLK
SETB SCLK ; READ DATA FROM SID
CLR SCLK
SETB SCLK ; READ DATA FROM SID
CLR SCLK
MOVBIT SID, A.3 ; SID = A.3
SETB SCLK ; READ DATA FROM SID
CLR SCLK
MOVBIT SID, A.2 ; SID = A.2
SETB SCLK ; READ DATA FROM SID
CLR SCLK
MOVBIT SID, A.1 ; SID = A.1
SETB SCLK ; READ DATA FROM SID
CLR SCLK
MOVBIT SID, A.0 ; SID = A.0
SETB SCLK ; READ DATA FROM SID
CLR SCLK
CLR SID ; SID = 0
SETB SCLK ; READ DATA FROM SID
CLR SCLK
SETB SCLK ; READ DATA FROM SID
CLR SCLK
SETB SCLK ; READ DATA FROM SID
CLR SCLK
SETB SCLK ; READ DATA FROM SID
CLR SCLK
SETB SCLK ; READ DATA FROM SID
CLR SCLK
CALL DLY8
RET

```

8 bit interface :

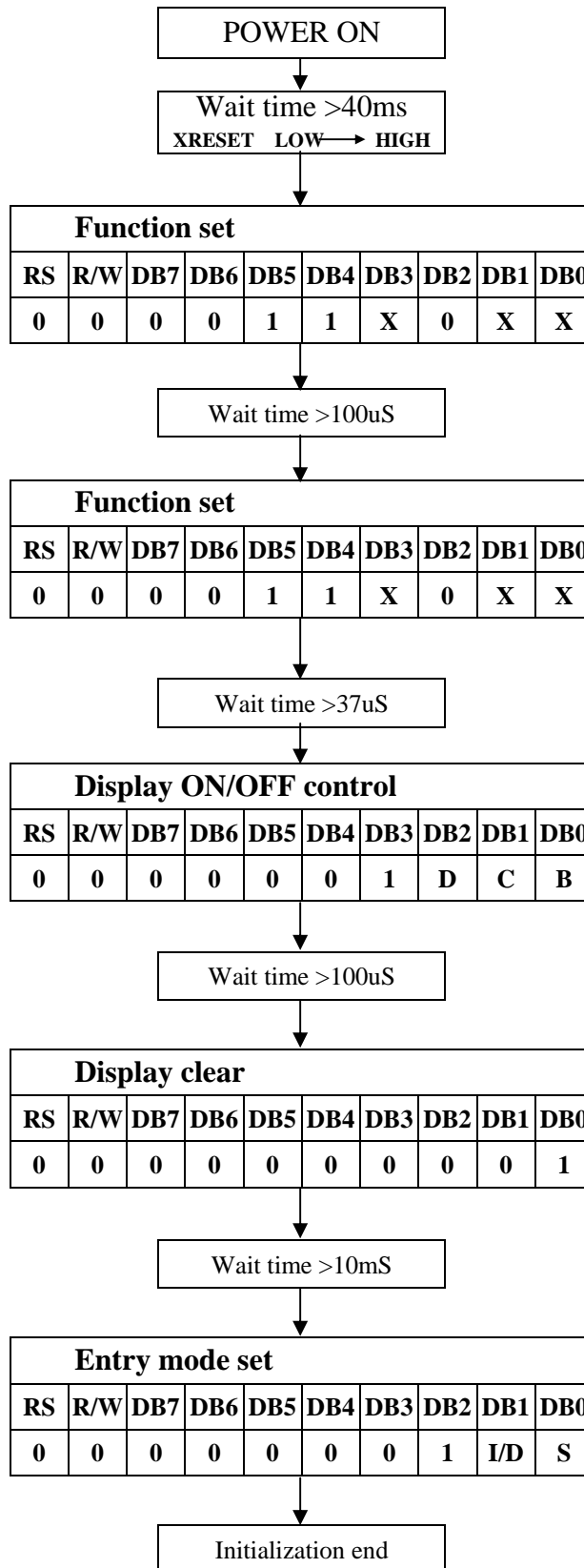

4 bit interface :

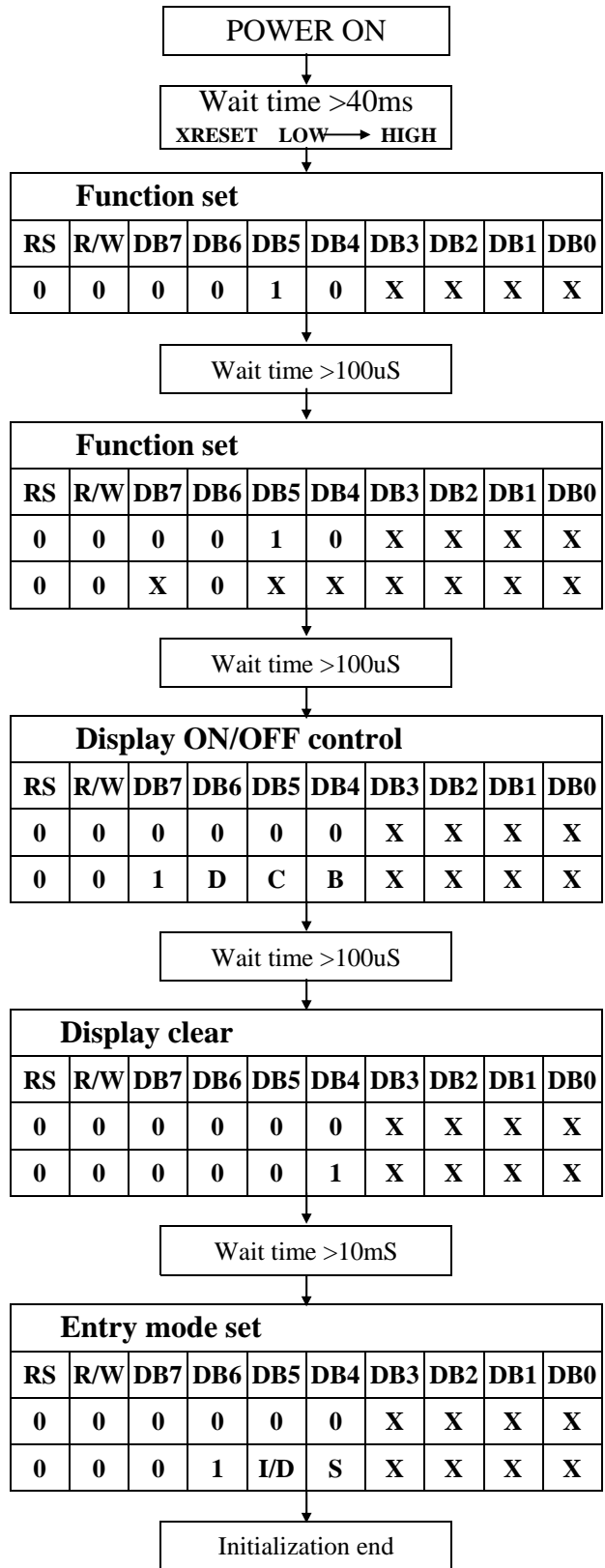

Built in voltage booster

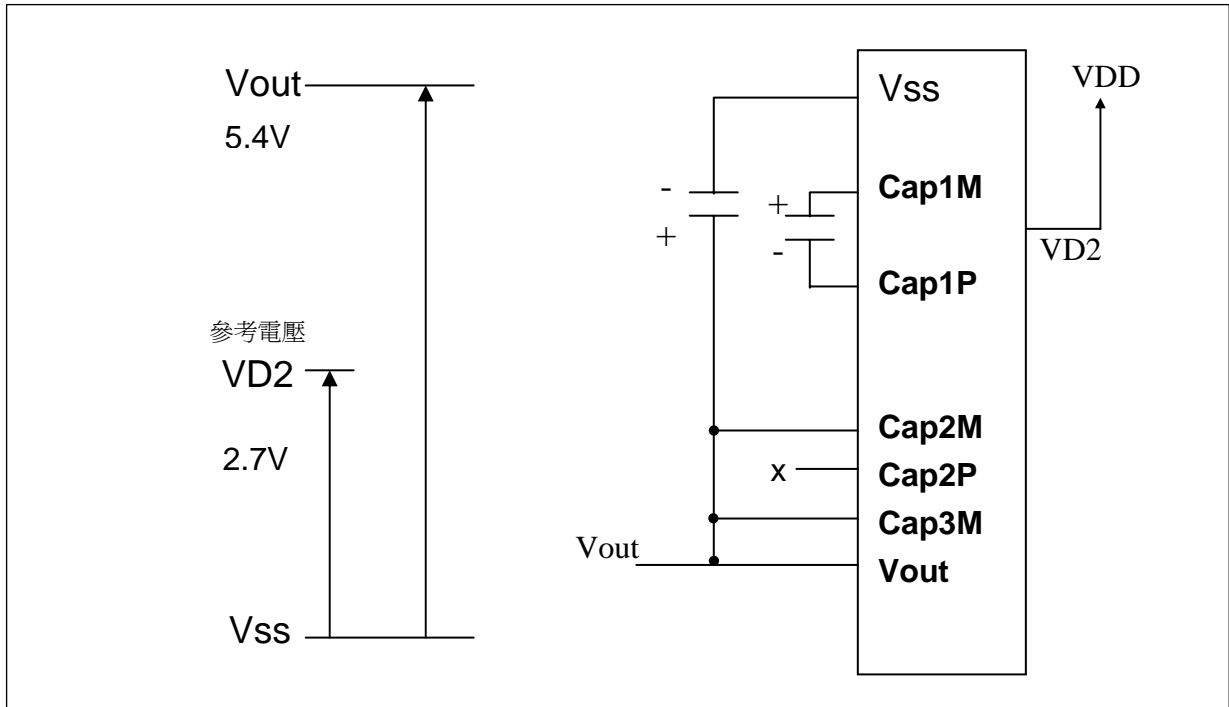

External reset timing

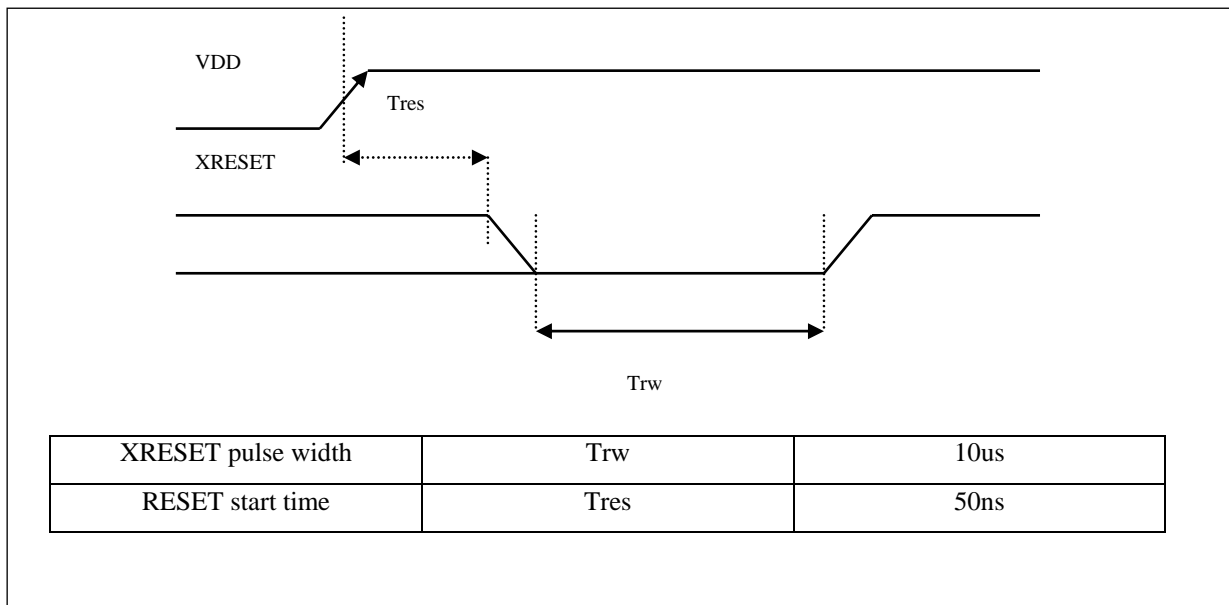

LCD driving wave form (1/33 duty , 1/5 bias)

When oscillation frequency is 540KHZ, 1 clock cycle time = 1.85us

1 frame = 1.85us x 300 x 33 = 18315us=18.3ms

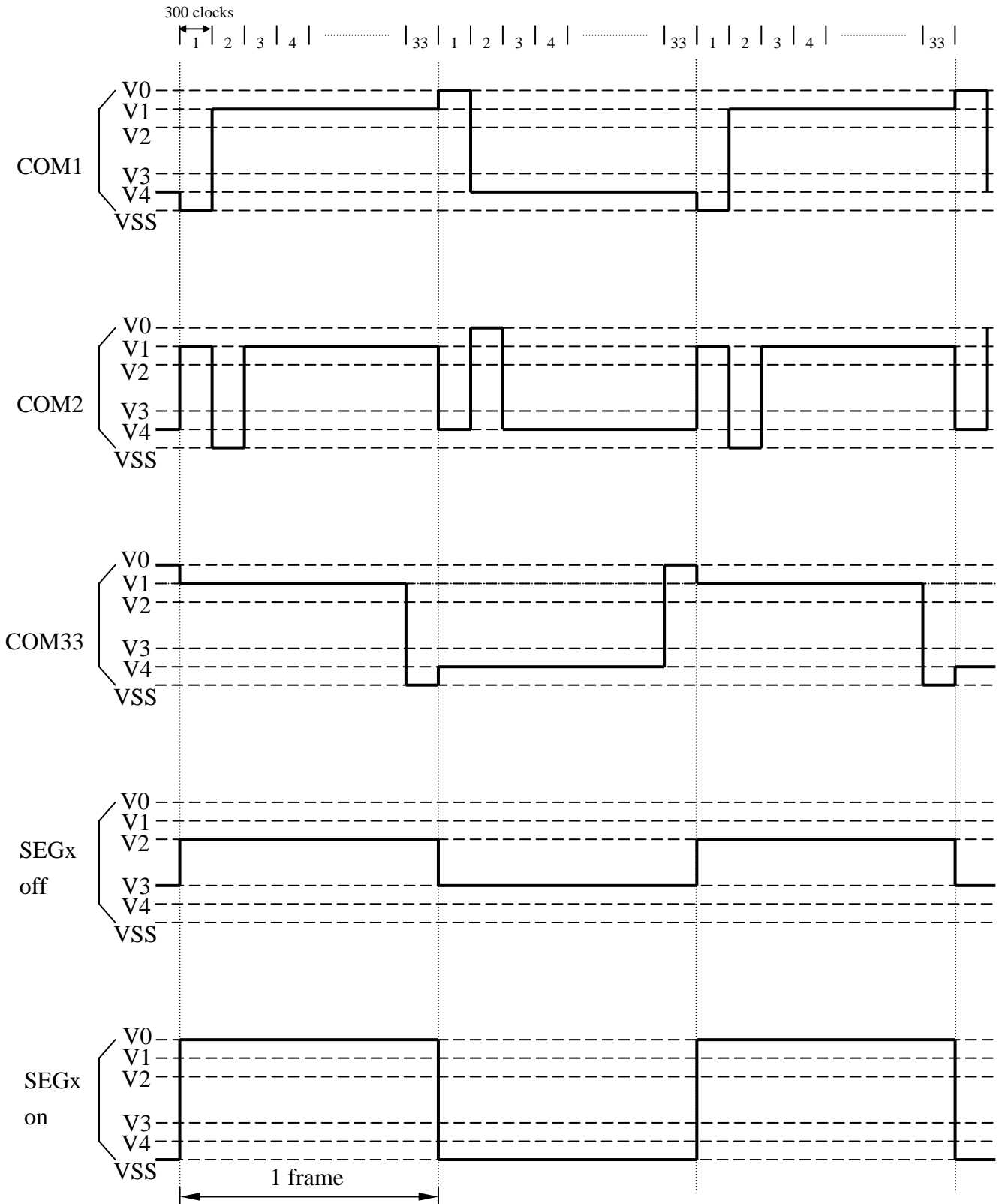

Absolute Maximum Ratings

Characteristics	Symbol	Value
Power Supply Voltage	V_{DD}	-0.3V to +5.5V
LCD Driver Voltage	V_{LCD}	-0.3V to +7.0V
Input Voltage	V_{IN}	-0.3V to $V_{DD}+0.3V$
Operating Temperature	T_A	-20°C to +85°C
Storage Temperature	T_{STO}	-55°C to +125°C

DC Characteristics ($T_A = 25^\circ\text{C}$, $V_{DD} = 2.7\text{ V} - 4.5\text{ V}$)

Symbol	Characteristics	Test Condition	Min.	Typ.	Max.	Unit
V_{DD}	Operating Voltage	-	2.7	-	5.5	V
V_{LCD}	LCD Voltage	V_0-V_{SS}	3.0	-	7	V
I_{CC}	Power Supply Current	$f_{OSC} = 530\text{KHz}$, $V_{DD}=3.0\text{V}$ $R_f=18\text{K}\Omega$	-	0.20	0.45	mA
V_{IH1}	Input High Voltage (Except OSC1)	-	$0.7V_{DD}$	-	V_{DD}	V
V_{IL1}	Input Low Voltage (Except OSC1)	-	-0.3	-	0.6	V
V_{IH2}	Input High Voltage (OSC1)	-	$V_{DD}-1$	-	V_{DD}	V
V_{IL2}	Input Low Voltage (OSC1)	-	-	-	1.0	V
V_{OH1}	Output High Voltage (DB0 - DB7)	$I_{OH} = -0.1\text{mA}$	$0.8V_{DD}$	-	V_{DD}	V
V_{OL1}	Output Low Voltage (DB0 - DB7)	$I_{OL} = 0.1\text{mA}$	-	-	0.1	V
V_{OH2}	Output High Voltage (Except DB0 - DB7)	$I_{OH} = -0.04\text{mA}$	$0.8V_{DD}$	-	V_{DD}	V
V_{OL2}	Output Low Voltage (Except DB0 - DB7)	$I_{OL} = 0.04\text{mA}$	-	-	$0.1V_{DD}$	V
I_{LEAK}	Input Leakage Current	$V_{IN} = 0\text{V to } V_{DD}$	-1	-	1	μA
I_{PUP}	Pull Up MOS Current	$V_{DD} = 3\text{V}$	22	27	32	μA

DC Characteristics ($T_A = 25^\circ\text{C}$, $V_{DD} = 4.5\text{ V} - 5.5\text{ V}$)

Symbol	Characteristics	Test Condition	Min.	Typ.	Max.	Unit
V_{DD}	Operating Voltage	-	4.5	-	5.5	V
V_{LCD}	LCD Voltage	$V_0 - V_{SS}$	3.0	-	7	V
I_{CC}	Power Supply Current	$f_{OSC} = 540\text{KHz}$, $V_{DD} = 5\text{V}$ $R_f = 33\text{K}\Omega$	-	0.45	0.75	mA
V_{IH1}	Input High Voltage (Except OSC1)	-	$0.7V_{DD}$	-	V_{DD}	V
V_{IL1}	Input Low Voltage (Except OSC1)	-	-0.3	-	0.6	V
V_{IH2}	Input High Voltage (OSC1)	-	$V_{DD} - 1$	-	V_{DD}	V
V_{IL2}	Input Low Voltage (OSC1)	-	-	-	1.0	V
V_{OH1}	Output High Voltage (DB0 - DB7)	$I_{OH} = -0.1\text{mA}$	$0.8V_{DD}$	-	V_{DD}	V
V_{OL1}	Output Low Voltage (DB0 - DB7)	$I_{OL} = 0.1\text{mA}$	-	-	0.4	V
V_{OH2}	Output High Voltage (Except DB0 - DB7)	$I_{OH} = -0.04\text{mA}$	$0.8V_{DD}$	-	V_{DD}	V
V_{OL2}	Output Low Voltage (Except DB0 - DB7)	$I_{OL} = 0.04\text{mA}$	-	-	$0.1V_{DD}$	V
I_{LEAK}	Input Leakage Current	$V_{IN} = 0\text{V to } V_{DD}$	-1	-	1	μA
I_{PUP}	Pull Up MOS Current	$V_{DD} = 5\text{V}$	75	80	85	μA

AC Characteristics ($T_A = 25^\circ\text{C}$, $V_{DD} = 4.5\text{V}$) Parallel Mode Interface

Symbol	Characteristics	Test Condition	Min.	Typ.	Max.	Unit
<i>Internal Clock Operation</i>						
f_{OSC}	OSC Frequency	R = 33K Ω	480	540	600	KHz
<i>External Clock Operation</i>						
f_{EX}	External Frequency	-	480	540	600	KHz
	Duty Cycle	-	45	50	55	%
$T_{\text{R}}, T_{\text{F}}$	Rise/Fall Time	-	-	-	0.2	μs
<i>Write Mode (Writing data from MPU to ST7920)</i>						
T_{C}	Enable Cycle Time	Pin E	1200	-	-	ns
T_{PW}	Enable Pulse Width	Pin E	140	-	-	ns
$T_{\text{R}}, T_{\text{F}}$	Enable Rise/Fall Time	Pin E	-	-	25	ns
T_{AS}	Address Setup Time	Pins: RS,RW,E	10	-	-	ns
T_{AH}	Address Hold Time	Pins: RS,RW,E	20	-	-	ns
T_{DSW}	Data Setup Time	Pins: DB0 - DB7	40	-	-	ns
T_{H}	Data Hold Time	Pins: DB0 - DB7	20	-	-	ns
<i>Read Mode (Reading Data from ST7920 to MPU)</i>						
T_{C}	Enable Cycle Time	Pin E	1200	-	-	ns
T_{PW}	Enable Pulse Width	Pin E	140	-	-	ns
$T_{\text{R}}, T_{\text{F}}$	Enable Rise/Fall Time	Pin E	-	-	25	ns
T_{AS}	Address Setup Time	Pins: RS,RW,E	10	-	-	ns
T_{AH}	Address Hold Time	Pins: RS,RW,E	20	-	-	ns
T_{DDR}	Data Delay Time	Pins: DB0 - DB7	-	-	100	ns
T_{H}	Data Hold Time	Pins: DB0 - DB7	20	-	-	ns
<i>Interface Mode with LCD Driver(ST7921)</i>						
T_{CWH}	Clock Pulse with High	Pins: CL1, CL2	800	-	-	ns
T_{CWL}	Clock Pulse with Low	Pins: CL1, CL2	800	-	-	ns
T_{CST}	Clock Setup Time	Pins: CL1, CL2	500	-	-	ns
T_{SU}	Data Setup Time	Pin: D	300	-	-	ns
T_{DH}	Data Hold Time	Pin: D	300	-	-	ns
T_{DM}	M Delay Time	Pin: M	-1000	-	1000	ns

AC Characteristics ($T_A = 25^\circ\text{C}$, $V_{DD} = 2.7\text{V}$) Parallel Mode Interface

Symbol	Characteristics	Test Condition	Min.	Typ.	Max.	Unit
<i>Internal Clock Operation</i>						
f_{OSC}	OSC Frequency	R = 18K Ω	470	530	590	KHz
<i>External Clock Operation</i>						
f_{EX}	External Frequency	-	470	530	590	KHz
	Duty Cycle	-	45	50	55	%
$T_{\text{R}}, T_{\text{F}}$	Rise/Fall Time	-	-	-	0.2	μs
<i>Write Mode (Writing data from MPU to ST7920)</i>						
T_{C}	Enable Cycle Time	Pin E	1800	-	-	ns
T_{PW}	Enable Pulse Width	Pin E	160	-	-	ns
$T_{\text{R}}, T_{\text{F}}$	Enable Rise/Fall Time	Pin E	-	-	25	ns
T_{AS}	Address Setup Time	Pins: RS,RW,E	10	-	-	ns
T_{AH}	Address Hold Time	Pins: RS,RW,E	20	-	-	ns
T_{DSW}	Data Setup Time	Pins: DB0 - DB7	40	-	-	ns
T_{H}	Data Hold Time	Pins: DB0 - DB7	20	-	-	ns
<i>Read Mode (Reading Data from ST7920 to MPU)</i>						
T_{C}	Enable Cycle Time	Pin E	1800	-	-	ns
T_{PW}	Enable Pulse Width	Pin E	320	-	-	ns
$T_{\text{R}}, T_{\text{F}}$	Enable Rise/Fall Time	Pin E	-	-	25	ns
T_{AS}	Address Setup Time	Pins: RS,RW,E	10	-	-	ns
T_{AH}	Address Hold Time	Pins: RS,RW,E	20	-	-	ns
T_{DDR}	Data Delay Time	Pins: DB0 - DB7	-	-	260	ns
T_{H}	Data Hold Time	Pins: DB0 - DB7	20	-	-	ns
<i>Interface Mode with LCD Driver(ST7921)</i>						
T_{CWH}	Clock Pulse with High	Pins: CL1, CL2	800	-	-	ns
T_{CWL}	Clock Pulse with Low	Pins: CL1, CL2	800	-	-	ns
T_{CST}	Clock Setup Time	Pins: CL1, CL2	500	-	-	ns
T_{SU}	Data Setup Time	Pin: D	300	-	-	ns
T_{DH}	Data Hold Time	Pin: D	300	-	-	ns
T_{DM}	M Delay Time	Pin: M	-1000	-	1000	ns

8 bit interface timing diagram

● MPU write data to ST7920

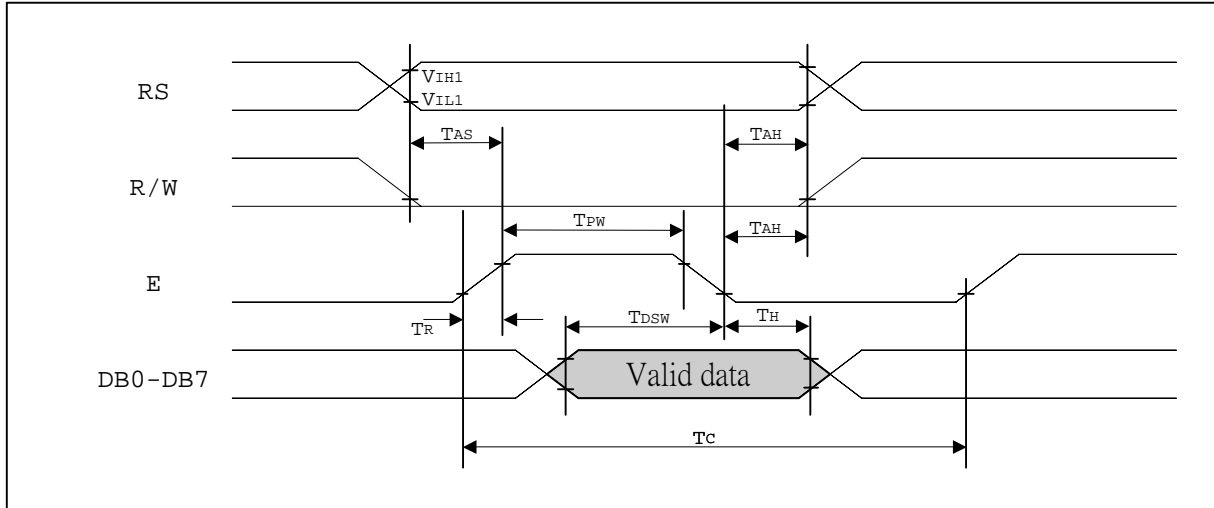

● MPU read data from ST7920

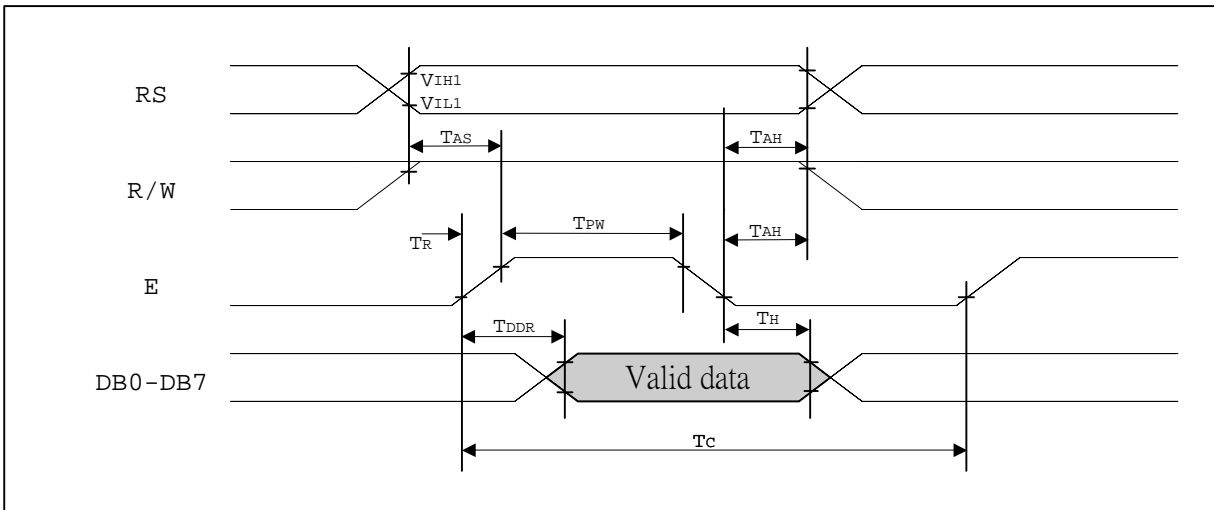

AC Characteristics ($T_A = 25^\circ\text{C}$, $V_{DD} = 4.5\text{V}$) Serial Mode Interface

Symbol	Characteristics	Test Condition	Min.	Typ.	Max.	Unit
<i>Internal Clock Operation</i>						
f_{OSC}	OSC Frequency	R = 33K Ω	470	530	590	KHz
<i>External Clock Operation</i>						
f_{EX}	External Frequency	-	470	530	590	KHz
	Duty Cycle	-	45	50	55	%
T_R, T_F	Rise/Fall Time	-	-	-	0.2	μs
TSCYC	Serial clock cycle	Pin E	400	-	-	ns
TSHW	SCLK high pulse width	Pin E	200	-	-	ns
TSLW	SCLK low pulse width	Pin E	200	-	-	ns
TSDS	SID data setup time	Pins RW	40	-	-	ns
TSDH	SID data hold time	Pins RW	40	-	-	ns
TCSS	CS setup time	Pins RS	60	-	-	ns
TCSH	CS hold time	Pins RS	60	-	-	ns

AC Characteristics ($T_A = 25^\circ\text{C}$, $V_{DD} = 2.7\text{V}$) Serial Mode Interface

Symbol	Characteristics	Test Condition	Min.	Typ.	Max.	Unit
<i>Internal Clock Operation</i>						
f_{OSC}	OSC Frequency	R = 18K Ω	470	530	590	KHz
<i>External Clock Operation</i>						
f_{EX}	External Frequency	-	470	530	590	KHz
	Duty Cycle	-	45	50	55	%
T_R, T_F	Rise/Fall Time	-	-	-	0.2	μs
TSCYC	Serial clock cycle	Pin E	600	-	-	ns
TSHW	SCLK high pulse width	Pin E	300	-	-	ns
TSLW	SCLK low pulse width	Pin E	300	-	-	ns
TSDS	SID data setup time	Pins RW	40	-	-	ns
TSDH	SID data hold time	Pins RW	40	-	-	ns
TCSS	CS setup time	Pins RS	60	-	-	ns
TCSH	CS hold time	Pins RS	60	-	-	ns

Serial interface timing diagram

- MPU write data to ST7920

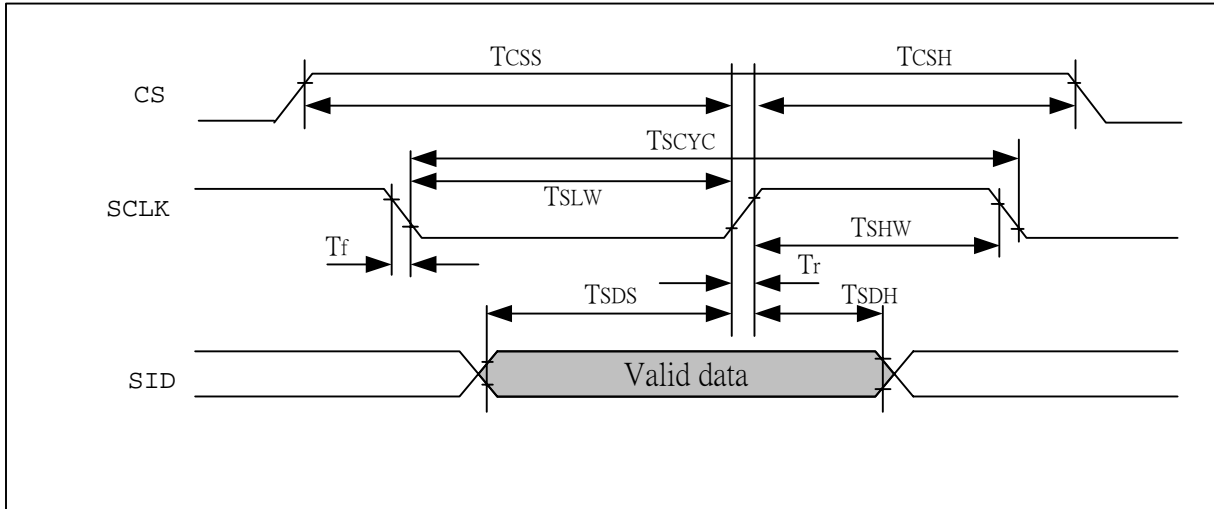

I/O pin diagram

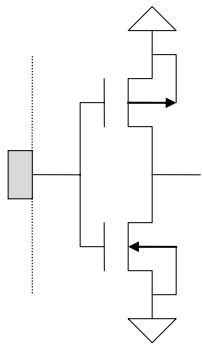

Input PAD: E (No Pull-up)

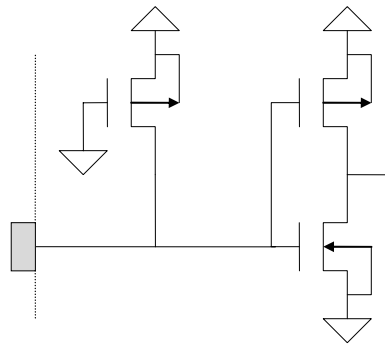

Input PAD: RS, RW (with Pull-up)

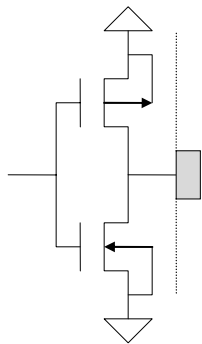

Output PAD: CL1, CL2, M, D

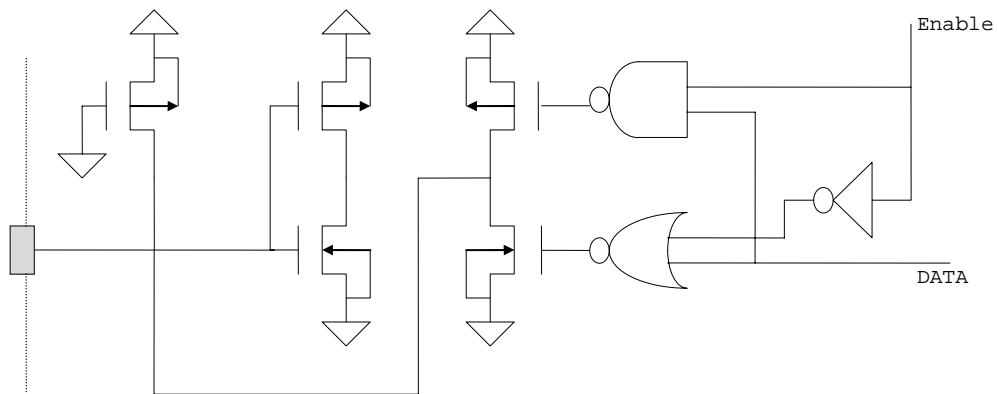

I/O PAD: DB0 – DB7

Application circuit 2 :

LCD : 32 COM x 160 SEG

LCD Voltage : VCC x 2 (Voltage doubler is used) *Vlcd should not over 7v.

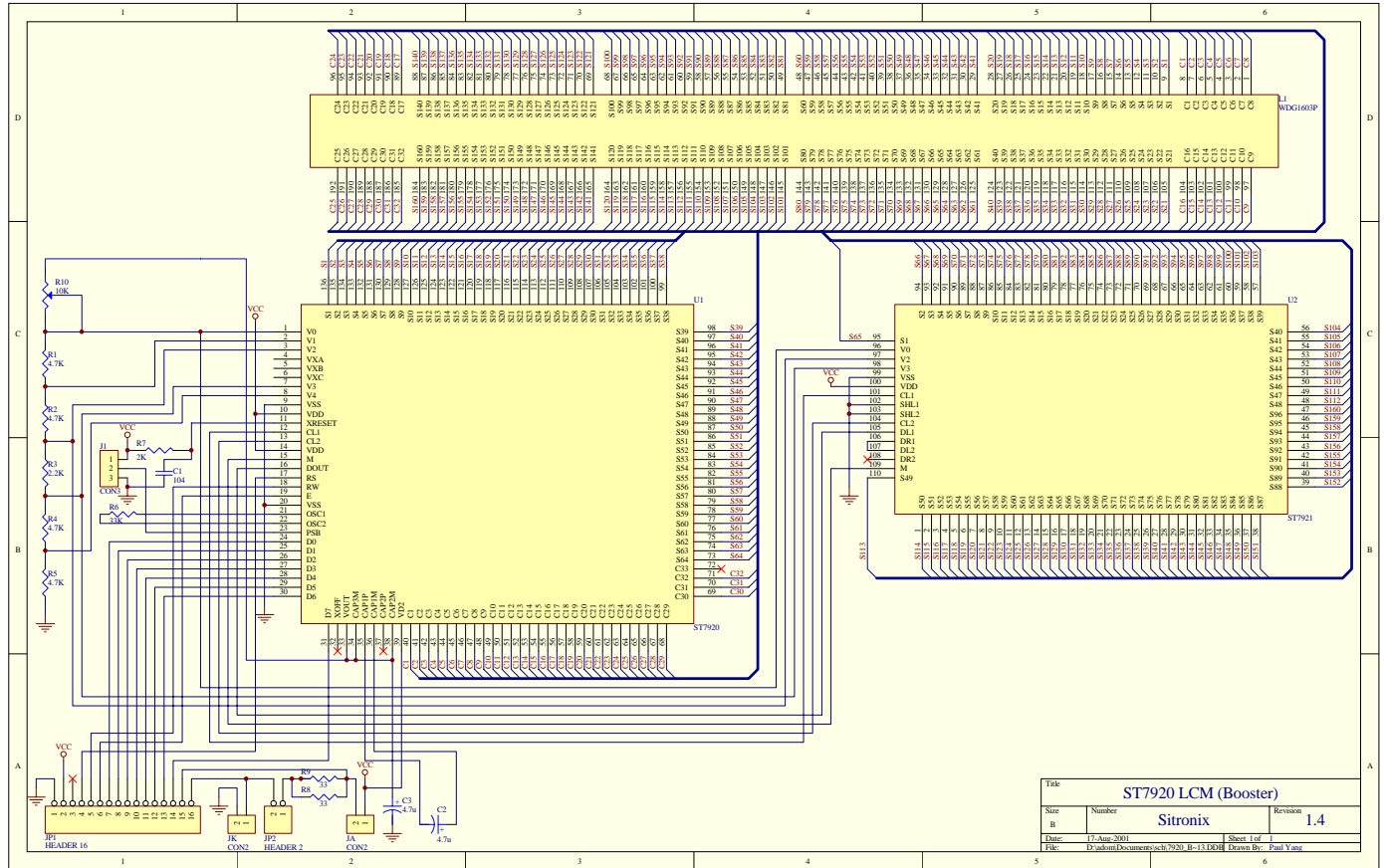

Application circuit 3 :

LCD : 2Line 16Chinese Word (32 COM x 256 SEG)

