



ST20P64

8 BIT Microcontroller with 64K bytes PROM(OTP)

PRELIMINARY

Notice: Sitronix Technology Corp. reserves the right to change the contents in this document without prior notice. This is not a final specification. Some parameters are subject to change.

1. FEATURES

- 8-bit static pipeline CPU
- ROM: 64K x 8-bit PROM(OTP)
- RAM: 2432 x 8-bit
- Stack: Up to 128-level deep
- Operation voltage:
 - DC-DC Converter Enable: 2.7V ~ 3.6V
 - DC-DC Converter Disable: 2.7V ~ 5.5V
- Built-in double DC-DC voltage converter for LCD driver
- I/O ports
 - 24 CMOS bidirectional bit programmable I/O pins, sixteen (Port-B/C) are shared with LCD drives
 - 8 open drain output pins are shared with LCD drives
 - 2 CMOS output pins are shared with PSG drives
 - Bit programmable pull-up for input pins
 - Hardware de-bounce option for Port-A
- Low voltage detector
- Timer/Counter:
 - Two 8-bit timer/16-bit event counter
 - One 8-bit Base timer
- 6 hardware interrupts with dedicated exception vectors
 - External interrupt (edge triggered)
 - Timer0 interrupt
 - Timer1 interrupt
 - Base timer interrupt
 - Port-A[7~0] interrupt (transition triggered)
 - DAC reload interrupt
- Dual clock sources with warm-up timer
 - Low frequency crystal oscillator 32768 Hz
 - RC oscillator 500K ~ 4M Hz
 - CPU clock..... 250K ~ 2M Hz
 - High frequency crystal/resonator oscillator (code option) 455K~4M Hz
 - CPU clock.....227.5k~2MHz
- LCD controller/driver
 - Resolution: 32x8 ~ 48x16, maximum 768 dots
 - Two clock source options: RC and resonator oscillator
 - Internal bias resistors (1/5 bias/1/4 bias) with 16-level driving strength control
 - Up to 16-level contrast control
 - Keyboard scan function supported on 16 shared segment drives
- Programmable sound generator (PSG)
 - Two channels with three playing modes
 - Tone/noise generator
 - 16-level volume control
 - Dedicated outputs for directly connection to buzzer
- PWM DAC: Three modes up to 8-bit resolution
- Three power down modes:
 - WAI0 mode
 - WAI1 mode
 - STP mode

2. GENERAL DESCRIPTION

The ST20P64 is a 8-bit intergrated microcontroller designed with CMOS silicon gate technology. This single chip microcontroller is useful for translator, databank and other consumer applications. It integrates with SRAM, Programming

ROM(OTP), LCD controller/driver, DC-DC voltage converter, I/O ports, timers, PSG and PWM DAC. This chip also builds in dual oscillators for the chip performance enhancement.

4. PAD CENTER COORDINATES

- Chip size: 2670 μ m X3470 μ m
- Coordinate: Pad center (μ m)
- Origin: Chip center
- Pad pitch: 110 μ m, 120 μ m
- Substrate connection: GND

Unit: μ m

PAD NO.	NAME	X	Y	PAD NO.	NAME	X	Y
1	SEG6	-1133.5	-1660	31	SEG36/PC4	1260	-200.5
2	SEG7	-1006.6	-1660	32	SEG37/PC5	1260	-86.1
3	SEG8	-894.9	-1660	33	SEG38/PC6	1260	22.2
4	SEG9	-785.9	-1660	34	SEG39/PC7	1260	142.4
5	SEG10	-676.1	-1660	35	SEG40/PB0	1260	251.6
6	SEG11	-567.8	-1660	36	SEG41/PB1	1260	364.5
7	SEG12	-458.2	-1660	37	SEG42/PB2	1260	473.6
8	SEG13	-349.8	-1660	38	SEG43/PB3	1260	585.1
9	SEG14	-239.9	-1660	39	SEG44/PB4	1260	693.2
10	SEG15	-130.8	-1660	40	SEG45/PB5	1260	801.8
11	SEG16	-21.4	-1660	41	SEG46/PB6	1260	913.9
12	SEG17	87.4	-1660	42	SEG47/PB7	1260	1023.9
13	SEG18	196.4	-1660	43	PSGO	1260	1144.5
14	SEG19	305.9	-1660	44	PSGOB	1260	1249.3
15	SEG20	415.8	-1660	45	TEST	1256.1	1477.4
16	SEG21	524.4	-1660	46	PVDD	1225.6	1660
17	SEG22	634.7	-1660	47	OSCXO	1106.6	1660
18	SEG23	743.3	-1660	48	OSCXI	996.6	1660
19	SEG24	849.8	-1660	49	RESET	886.3	1660
20	SEG25	960.1	-1660	50	OSCI	777.1	1660
21	SEG26	1075.1	-1660	51	XIO	668.1	1660
22	SEG27	1260	-1445.2	52	VPP	565	1660
23	SEG28	1260	-1343.9	53	GND	439.8	1660
24	SEG29	1260	-1216.4	54	VDD	278.5	1660
25	SEG30	1260	-1101.3	55	PA0	152.9	1660
26	SEG31	1260	-1003.7	56	PA1	34.7	1660
27	SEG32/PC0	1260	-651.2	57	PA2	-74.3	1660
28	SEG33/PC1	1260	-533.2	58	PA3	-179.9	1660
29	SEG34/PC2	1260	-430.5	59	PA4	-308.2	1660
30	SEG35/PC3	1260	-320.5	60	PA5	-417.8	1660

PAD NO.	NAME	X	Y	PAD NO.	NAME	X	Y
61	PA6	-524.6	1660	76	COM8	-1260	241.4
62	PA7	-634.7	1660	77	COM9	-1260	93
63	CAP1+	-753.5	1660	78	COM10	-1260	-51.6
64	CAP1-	-873.3	1660	79	COM11	-1260	-187.9
65	V3	-1006.4	1660	80	COM12	-1260	-331.2
66	V2	-1121.4	1660	81	COM13	-1260	-479.2
67	VP	-1274.9	1660	82	COM14	-1260	-625.7
68	COM0	-1260	1307.9	83	COM15	-1260	-755.6
69	COM1	-1260	1155.4	84	SEG0	-1260	-911.3
70	COM2	-1260	1013.4	85	SEG1	-1260	-1030.3
71	COM3	-1260	866.3	86	SEG2	-1260	-1142.7
72	COM4	-1260	746.1	87	SEG3	-1260	-1251.8
73	COM5	-1260	601.9	88	SEG4	-1260	-1357
74	COM6	-1260	480.4	89	SEG5	-1260	-1469.5
75	COM7	-1260	363.2				

5. BLOCK DIAGRAM

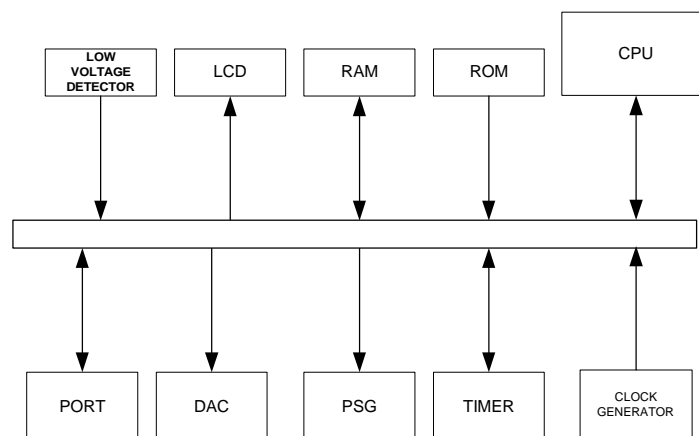

6. PAD DESCRIPTION

Pin No.	Designation	I/O	Description
70~73	COM2/SCK COM3/SS COM4/MOSI COM5/MISO	I/O	LCD common drive output pins, drives 2~5 SPI interface for OTP programming.
68, 69, 74, 75	COM0,1, 6, 7	O	LCD common drive output pins, drives 0, 1, 6, 7
76~83	COM8~15	O O	LCD common drive output pins, drives 8~15 Common open drain output port.
84~89, 1~26	SEG0~31	O	LCD segment drive output pins, drives 0~31
55	PA0 / INTX	I/O I I I	- Port-A bit programmable I/O - Edge-trigger Interrupt. - Transition-trigger Interrupt - Programmable Timer1 clock source
56~62	PA1~7	I/O I	- Port-A bit programmable I/O - Transition-trigger Interrupt
35~42	SEG40/PB0~ SEG47/PB7	I/O O	- Port-B bit programmable I/O - LCD segment drives 40~47
27~34	SEG32/PC0~ SEG39/PC7	I/O O	- Port-C bit programmable I/O - LCD segment drives 32~39
46	PVDD	P	PSG Power supply pin
44, 43	PSGOB,PSGO	O	PSG/ PWM DAC Outputs
47, 48	OSC XO, OSC XI	I/O	Low frequency crystal oscillator I/O pins. Connect to external 32768 Hz crystal.
49	RESET	I	Reset signal input (low active)
50	OSCI	I I	- RC oscillator input pin. Connected to external resistor - High frequency crystal/resonator oscillator input pin. Connect to external crystal/resonator.
51	XIO	O	- NC - High frequency crystal/resonator oscillator output pin. Connect to external crystal/resonator.
53	GND	P	Ground pin
54	VDD	P	Power supply pin
63	CAP1+	I/O	Connect to booster capacitor positive(+) terminal
64	CAP1-	I/O	Connect to booster capacitor negative(-) terminal
66, 65	V2, V3	P	Multi-level power supply for the liquid crystal drive
67	VP	O	Voltage output of booster circuit
45	TEST	I	Chip test function. Leave it open.

Note: I = input, O = output, I/O = input/output, P = power.

7. CPU

Register Model

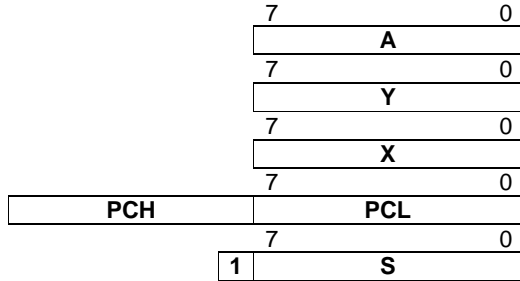

Accumulator A

Index Register Y

Index Register X

Program Counter PC

Stack Pointer S

Accumulator (A)

The Accumulator is a general-purpose 8-bit register that stores the results of most arithmetic and logic operations. In addition, the accumulator usually contains one of the two data which used in these operations.

Index Registers (X,Y)

There are two 8-bit Index Registers (X and Y), which may be used to count program steps or to provide an index value to be used in generating an effective address. When executing an instruction, which specifies indexed addressing, the CPU fetches the OP code and the base address, and modifies the address by adding the index register to it prior to performing the desired operation. Pre or post-indexing of indirect addresses is possible.

Stack Pointer (S)

The Stack Pointer is an 8-bit register, which is used to control the addressing of the variable-length stack. Its range from 100H to 1FFH total for 256 bytes (128 level deep). The stack pointer is automatically incremented and decremented under control of the microprocessor to perform stack manipulations under

direction of either the program or interrupts (IRQ). The stack allows simple implementation of nested subroutines and multiple level interrupts. The stack pointer is initialized by the user's software.

Program Counter (PC)

The 16-bit Program Counter register provides the address, which steps the microprocessor through sequential program instructions. Each time the microprocessor fetches an instruction from program memory, the lower byte of the program counter (PCL) is placed on the low-order bits of the address bus and the higher byte of the program counter (PCH) is placed on the high-order 8 bits. The counter is incremented each time an instruction or data is fetched from program memory.

Status Register (P)

The 8-bit Processor Status Register contains seven status flags. Some of these flags are controlled by program; others may be controlled both by the program and the CPU. The instruction set contains a member of conditional branch instructions that are designed to allow testing of these flags. Refer to TABLE 7-1

TABLE 7-1 Status Register (P)

Bit 7	Bit 6	Bit 5	Bit 4	Bit 3	Bit 2	Bit 1	Bit 0
N	V	1	B	D	I	Z	C
Bit 7: N : Signed flag by arithmetic 1 = Negative 0 = Positive				Bit 3: D : Decimal mode flag 1 = Decimal mode 0 = Binary mode			
Bit 6: V : Overflow of signed Arithmetic flag 1 = Negative 0 = Positive				Bit 2: I : Interrupt disable flag 1 = Interrupt disable 0 = Interrupt enable			
				Bit 1: Z : Zero flag 1 = Zero 0 = Non zero			
Bit 4: B : BRK interrupt flag 1 = BRK interrupt occur 0 = Non BRK interrupt occur				Bit 0: C : Carry flag 1 = Carry 0 = Non carry			

8. MEMORY CONFIGURATION

8.1 Memory map

ST20P64 builds in 64K bytes PROM and 2432 bytes RAM. The internal ROM can be used as data memory or program memory. PRR is the Program ROM Bank Register and DRR is the Data ROM Bank Register. The logical program ROM address is from \$4000 to \$7FFF (16K bytes), and \$8000 to \$FFFF (32K bytes) is for logical data ROM address.

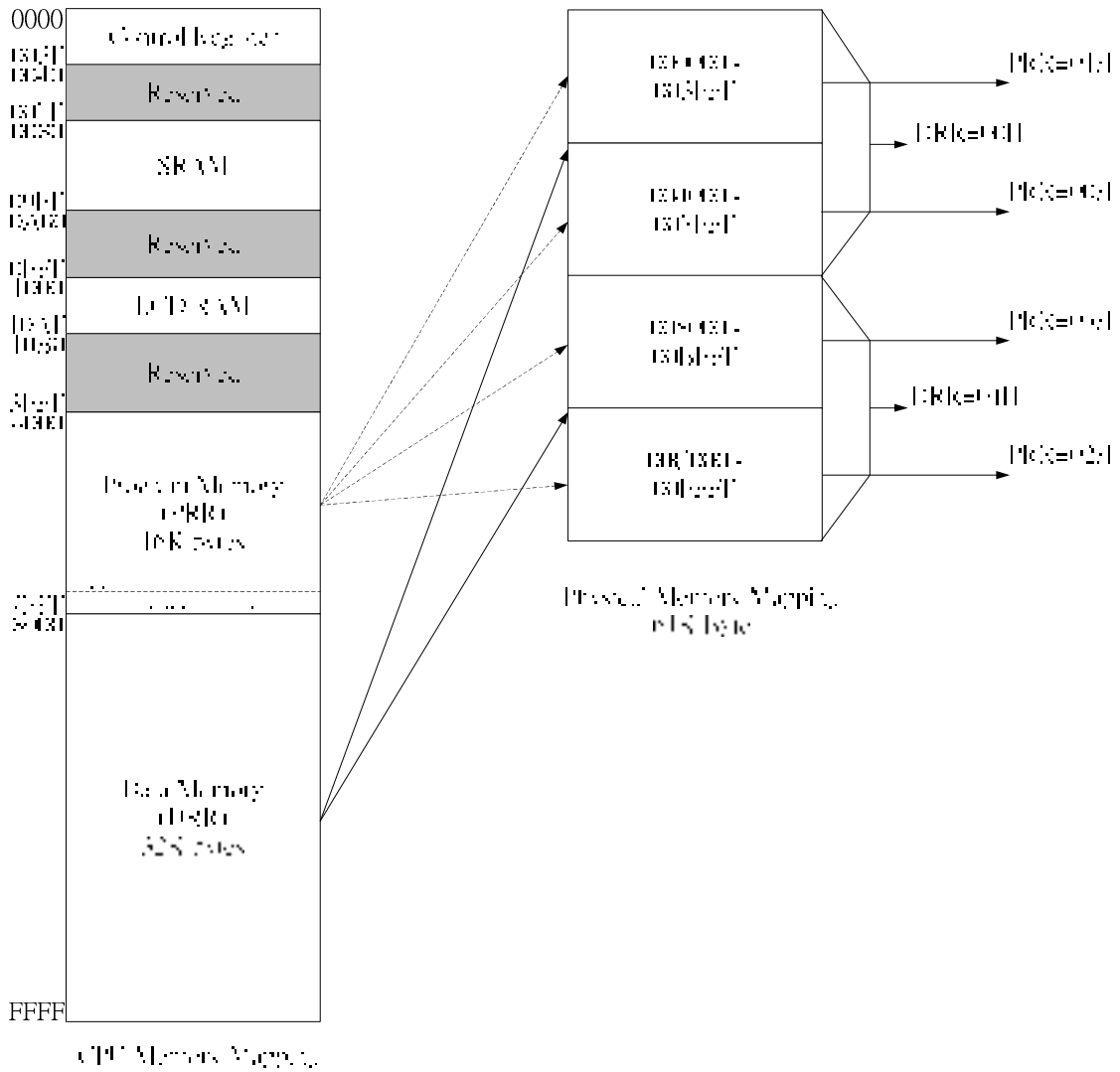

8.2 ROM

8.2.1 Bank Description

Setting corresponding value to register PRR (program memory) or DRR (data memory) when user wants uses different memory bank.

FIGURE 8-1 ROM Bank Selection Registers (\$31~\$32)

Address	Register	R/W	Bit7	Bit6	Bit5	Bit4	Bit3	Bit2	Bit1	Bit0
PRR	\$31	RW	-	-	-	-	-	-	PRR1	PRR0
DRR	\$32	RW	-	-	-	-	-	-	-	DRR0

8.3 RAM

Internal static RAM is for control registers, data RAM, stack RAM and the LCD frame buffer.

8.3.1 Control Registers

Address	Name	R/W	Bit 7	Bit 6	Bit 5	Bit 4	Bit 3	Bit 2	Bit 1	Bit 0	Default
\$000	PA	R/W	PA[7]	PA[6]	PA[5]	PA[4]	PA[3]	PA[2]	PA[1]	PA[0]	1111 1111
\$001	PB	R/W	PB[7]	PB[6]	PB[5]	PB[4]	PB[3]	PB[2]	PB[1]	PB[0]	1111 1111
\$002	PC	R/W	PC[7]	PC[6]	PC[5]	PC[4]	PC[3]	PC[2]	PC[1]	PC[0]	1111 1111
\$008	PCA	R/W	PCA[7]	PCA[6]	PCA[5]	PCA[4]	PCA[3]	PCA[2]	PCA[1]	PCA[0]	0000 0000
\$009	PCB	R/W	PCB[7]	PCB[6]	PCB[5]	PCB[4]	PCB[3]	PCB[2]	PCB[1]	PCB[0]	0000 0000
\$00A	PCC	R/W	PCC[7]	PCC[6]	PCC[5]	PCC[4]	PCC[3]	PCC[2]	PCC[1]	PCC[0]	0000 0000
\$00E	PAK	R/W	PAK[7]	PAK[6]	PAK[5]	PAK[4]	PAK[3]	PAK[2]	PAK[1]	PAK[0]	0000 0000
\$00F	PMCR	R/W	PULL	PDBN	INTEG	-	TEST	-	-	-	100 - 0- - -
\$010	PSG0L	R/W	PSG0[7]	PSG0[6]	PSG0[5]	PSG0[4]	PSG0[3]	PSG0[2]	PSG0[1]	PSG0[0]	0000 0000
\$011	PSG0H	R/W	-	-	-	-	PSG0[11]	PSG0[10]	PSG0[9]	PSG0[8]	- - - - 0000
\$012	PSG1L	R/W	PSG1[7]	PSG1[6]	PSG1[5]	PSG1[4]	PSG1[3]	PSG1[2]	PSG1[1]	PSG1[0]	0000 0000
\$013	PSG1H	R/W	-	-	-	-	PSG1[11]	PSG1[10]	PSG1[9]	PSG1[8]	- - - - 0000
\$014	DAC	R/W	DAC[7]	DAC[6]	DAC[5]	DAC[4]	DAC[3]	DAC[2]	DAC[1]	DAC[0]	0000 0000
\$015	PSGC2	R/W	-	-	-	-	PSGOD	PSGOBD	PSGOE	PSGOBE	- - - - 1111
\$016	PSGC	R/W	-	PCK[2]	PCK[1]	PCK[0]	PRBS	C1EN	C0EN	DACE=0	-000 0000
		R/W	-	PCK[2]	PCK[1]	PCK[0]	DMD[1]	DMD[0]	INH	DACE=1	-000 0000
\$017	VOL	R/W	VOL1[3]	VOL1[2]	VOL1[1]	VOL1[0]	VOL0[3]	VOL0[2]	VOL0[1]	VOL0[0]	0000 0000
\$021	BTM	R/W	-	-	-	-	BTM[3]	BTM[2]	BTM[1]	BTM[0]	- - - - 0000
\$023	PRS	R	PRS[7]	PRS[6]	PRS[5]	PRS[4]	PRS[3]	PRS[2]	PRS[1]	PRS[0]	0000 0000
		W	SRES	SENA	SENT	-	-	-	-	-	-
\$024	T0M	R/W	-	-	T0M[5]	T0M[4]	-	T0M[2]	T0M[1]	T0M[0]	- - 00 -000
\$025	T0C	R/W	T0C[7]	T0C[6]	T0C[5]	T0C[4]	T0C[3]	T0C[2]	T0C[1]	T0C[0]	0000 0000
\$026	T1M	R/W	-	-	-	T1M[4]	T1M[3]	T1M[2]	T1M[1]	T1M[0]	- - -0 0000
\$027	T1C	R/W	T1C[7]	T1C[6]	T1C[5]	T1C[4]	T1C[3]	T1C[2]	T1C[1]	T1C[0]	0000 0000
\$030	SYS	R/W	XSEL	OSTP	XSTP	TEST	WSKP	WAIT	-	LVDET	0000 00 -0
\$031	PRR	R/W	-	-	-	-	-	-	PRR[1]	PRR[0]	- - - - -00
\$032	DRR	R/W	-	-	-	-	-	-	-	DRR[0]	- - - - -0
\$036	COM	R/W	COM[7]	COM[6]	COM[5]	COM[4]	COM[3]	COM[2]	COM[1]	COM[0]	???? ????
\$039	LSEL	R/W	DUTY[1]	DUTY[0]	BIAS4	LSEL[4]	LSEL[3]	LSEL[2]	LSEL[1]	LSEL[0]	0001 1111
\$03A	LCTL	R/W	LPWR	BLANK	REV	SCAN	CTR[3]	CTR[2]	CTR[1]	CTR[0]	1000 0000
\$03B	LCK	R/W	DRV[3]	DRV[2]	DRV[1]	DRV[0]	PUMPB	LCK[2]	LCK[1]	LCK[0]	1111 0000
\$03C	IREQ	R/W	-	-	IRBT	IRPT	IRT1	IRT0	IRDAC	IRX	- - 00 0000
\$03E	IENA	R/W	-	-	IEBT	IEPT	IET1	IET0	IEDAC	IEX	- - 00 0000

Note: 1. Undefined bytes and bits should not be used.

2. Do not use bit modification instructions for write-only registers, such as RMBx, SMBx.

8.3.2 Data RAM (\$0080~\$09FF)

Data RAM are organized in 2432 bytes from \$0080~\$09FF.

8.3.3 Stack RAM (\$0100~\$01FF)

Stack RAM is organized in 256 bytes. It provides for a maximum of 128-level subroutine stacks and can be used as data memory.

8.3.4 LCD Frame Buffer (\$1000~\$10AF)

LCD frame buffer is accessible by both read/write instructions and LCD controller. Note that this area can also be used as data memory. Each pixel of LCD panel is directly mapped into this area. Refer to section 15.3 for the detail mapping.

9. INTERRUPTS

9.1 Interrupt description

Brk

Instruction 'BRK' will cause software interrupt when interrupt disable flag (I) is cleared. Hardware will push 'PC', 'P' Register to stack and set interrupt disable flag (I). Program counter then will be loaded with the BRK vector from locations \$7FFE and \$7FFF.

Reset

A positive transition of RESET pin will then cause an initialization sequence to begin. After the system has been operating, a low on this line at least of two clock cycles will cease ST20P64 activity. When a positive edge is detected, there is an initialization sequence lasting six clock cycles. Then the interrupt mask flag is set, the decimal mode is cleared and the program counter will loaded with the restart vector from locations \$7FFC (low byte) and \$7FFD (high byte). This is the start location for program control. This input should be high in normal operation.

INTX Interrupt

The IRX (INTX interrupt request) flag will be set while INTX edge signal occurs. The INTX interrupt will be active once IEX (INTX interrupt enable) is set, and interrupt mask flag is cleared. Hardware will push 'PC', 'P' Register to stack and set interrupt mask flag (I). Program counter will be loaded with the INTX vector from locations \$7FF8 and \$7FF9.

DAC Interrupt

The IRDAC (DAC interrupt request) flag will be set while reload signal of DAC occurs. Then the DAC interrupt will be executed when IEDAC (DAC interrupt enable) is set, and interrupt mask flag is cleared. Hardware will push 'PC', 'P' Register to stack and set interrupt mask flag (I). Program counter will be loaded with the DAC vector from locations \$7FF6 and \$7FF7.

T0 Interrupt

The IRT0 (TIMER0 interrupt request) flag will be set while T0 overflows. With IET0 (TIMER0 interrupt enable) being set, the T0 interrupt will execute, and interrupt mask flag will be cleared. Hardware will push 'PC', 'P' Register to stack and set interrupt mask flag (I). Program counter will be loaded with the T0 vector from locations \$7FF4 and \$7FF5.

T1 Interrupt

The IRT1 (TIMER1 interrupt request) flag will be set while T1 overflows. With IET1 (TIMER1 interrupt enable) being set, the T1 interrupt will execute, and interrupt mask flag will be cleared. Hardware will push 'PC', 'P' Register to stack and set interrupt mask flag (I). Program counter will be loaded with the T1 vector from locations \$7FF2 and \$7FF3.

PT Interrupt

The IRPT (Port-A interrupt request) flag will be set while Port-A transition signal occurs. With IEPT (PT interrupt enable) being set, the PT interrupt will be execute, and interrupt mask flag will be cleared. Hardware will push 'PC', 'P' Register to stack and set interrupt mask flag (I). Program counter will be loaded with the PT vector from locations \$7FF0 and \$7FF1.

BT Interrupt

The IRBT (Base timer interrupt request) flag will be set when Base Timer overflows. The BT interrupt will be executed once the IEBT (BT interrupt enable) is set and the interrupt mask flag is cleared. Hardware will push 'PC', 'P' Register to stack and set interrupt mask flag (I). Program counter will be loaded with the BT vector from locations \$7FEE and \$7FEF.

All interrupt vectors are listed in TABLE 9-1.

TABLE 9-1 Interrupt Vectors

Name	Signal	Vector address	Priority	Comment
BRK	Internal	\$7FFF,\$7FFE	8	Software BRK operation vector
RESET	External	\$7FFD,\$7FFC	1	Reset vector
-	-	\$7FFB,\$7FFA	-	Reserved
INTX	External	\$7FF9,\$7FF8	2	PA0 edge interrupt
DAC	Internal	\$7FF7,\$7FF6	3	Reload DAC data interrupt
T0	INT/EXT	\$7FF5,\$7FF4	4	Timer0 interrupt
T1	INT/EXT	\$7FF3,\$7FF2	5	Timer1 interrupt
PT	External	\$7FF1,\$7FF0	6	Port-A transition interrupt
BT	Internal	\$7FEF,\$7FEE	7	Base Timer interrupt

9.2 Interrupt Request Flag

Interrupt request flag can be cleared by two methods. One is to write "0" to IREQ, the other is to initiate the interrupt service

routine when interrupt occurs. Hardware will automatically clear the Interrupt flag.

TABLE 9-2 Interrupt Request Register (IREQ)

Address	Name	R/W	Bit 7	Bit 6	Bit 5	Bit 4	Bit 3	Bit 2	Bit 1	Bit 0	Default
\$03C	IREQ	R/W	-	-	IRBT	IRPT	IRT1	IRT0	IRDAC	IRX	--000000
Bit 5: IRBT : Base Timer Interrupt Request bit 1 = Time base interrupt occurs 0 = Time base interrupt doesn't occur						Bit 2: IRT0 : Timer0 Interrupt Request bit 1 = Timer0 overflow interrupt occurs 0 = Timer0 overflow interrupt doesn't occur					
Bit 4: IRPT : Port-A Interrupt Request bit 1 = Port-A transition interrupt occurs 0 = Port-A transition interrupt doesn't occur						Bit 1: IRDAC : DAC reload Interrupt Request bit 1 = DAC time out interrupt occurs 0 = DAC time out interrupt doesn't occur					
Bit 3: IRT1 : Timer1 Interrupt Request bit 1 = Timer1 overflow interrupt occurs 0 = Timer1 overflow interrupt doesn't occur						Bit 0: IRX : INTX Interrupt Request bit 1 = INTX edge interrupt occurs 0 = INTX edge interrupt doesn't occur					

TABLE 9-3 Interrupt Enable Register (IENA)

Address	Name	R/W	Bit 7	Bit 6	Bit 5	Bit 4	Bit 3	Bit 2	Bit 1	Bit 0	Default
\$03E	IENA	*R/W	-	-	IEBT	IEPT	IET1	IET0	IEDAC	IEX	--000000
Bit 5: IEBT : Base Timer Interrupt Enable bit 1 = Time base interrupt enable 0 = Time base interrupt disable						Bit 2: IET0 : Timer0 Interrupt Enable bit 1 = Timer0 overflow interrupt enable 0 = Timer0 overflow interrupt disable					
Bit 4: IEPT : Port-A Interrupt Enable bit 1 = Port-A transition interrupt enable 0 = Port-A transition interrupt disable						Bit 1: IEDAC : DAC reload Interrupt Enable bit 1 = DAC time out interrupt enable 0 = DAC time out interrupt disable					
Bit 3: IET1 : Timer1 Interrupt Enable bit 1 = Timer1 overflow interrupt enable 0 = Timer1 overflow interrupt disable						Bit 0: IEX : INTX Interrupt Enable bit 1 = INTX edge interrupt enable 0 = INTX edge interrupt disable					

10. I/O PORTS

10.1 Description

ST20P64 can supply total 24 GPIOs divided into three I/O ports, Port-A, Port-B, and Port-C. Besides I/O function, Port-B/C can also be used as LCD segment drives. For detail pin assignment, please refer to TABLE 10-1

NOTE: all of unused input pins should be pulled up to minimize standby current

TABLE 10-1 I/O Description

PORT NAME	PAD NAME	PAD NUMBER	PIN TYPE	FEATURE
Port-A	PA0/INTX	55	I/O	Programmable input/output pin
	PA1	56	I/O	
	PA2	57	I/O	
	PA3	58	I/O	
	PA4	59	I/O	
	PA5	60	I/O	
	PA6	61	I/O	
	PA7	62	I/O	
Port-B	SEG40/PB0	35	I/O	Programmable input/output pin
	SEG41/PB1	36	I/O	
	SEG42/PB2	37	I/O	
	SEG43/PB3	38	I/O	
	SEG44/PB4	39	I/O	
	SEG45/PB5	40	I/O	
	SEG46/PB6	41	I/O	
	SEG47/PB7	42	I/O	
Port-C	SEG32/PC0	27	I/O	Programmable input/output pin
	SEG33/PC1	28	I/O	
	SEG34/PC2	29	I/O	
	SEG35/PC3	30	I/O	
	SEG36/PC4	31	I/O	
	SEG37/PC5	32	I/O	
	SEG38/PC6	33	I/O	
	SEG39/PC7	34	I/O	
COM[8~15]	COM8	76	O	Programmable open drain output pin
	COM9	77	O	
	COM10	78	O	
	COM11	79	O	
	COM12	80	O	
	COM13	81	O	
	COM14	82	O	
	COM15	83	O	

10.2 Port-A

10.2.1 Port-A Description

Port-A is a bit-programmable bi-direction I/O port, which is controlled by PCA register. It also provides bit programmable pull-up resistor for each input pin. Two interrupts can be

triggered by Port-A, de-bounced interrupt for keyboard scan and edge sensitive interrupt (PA0 only) for external event.

TABLE 10-2 Summary Of Port-A Registers

Address	Name	R/W	Bit 7	Bit 6	Bit 5	Bit 4	Bit 3	Bit 2	Bit 1	Bit 0	Default
\$000	PA	R/W	PA[7]	PA[6]	PA[5]	PA[4]	PA[3]	PA[2]	PA[1]	PA[0]	1111 1111
\$008	PCA	R/W	PCA[7]	PCA[6]	PCA[5]	PCA[4]	PCA[3]	PCA[2]	PCA[1]	PCA[0]	0000 0000
\$00E	PAK	R/W	PAK[7]	PAK[6]	PAK[5]	PAK[4]	PAK[3]	PAK[2]	PAK[1]	PAK[0]	0000 0000
\$00F	PMCR	R/W	PULL	PDBN	INTEG	-	TEST	-	-	-	100 - 0- - -
\$03C	IREQ	R/W	-	-	IRBT	IRPT	IRT1	IRT0	IRDAC	IRX	- - 00 0000
\$03E	IENA	R/W	-	-	IEBT	IEPT	IET1	IET0	IEDAC	IEX	- - 00 0000

10.2.2 Port-A I/O Control

Direction of Port-A is controlled by PCA. Each bit of PCA controls the direction of one single I/O of Port-A respectively,

with "1" for output mode, and "0" for input mode.

TABLE 10-3 Port-A Control Register (PCA)

Address	Name	R/W	Bit 7	Bit 6	Bit 5	Bit 4	Bit 3	Bit 2	Bit 1	Bit 0	Default
\$008	PCA	R/W	PCA[7]	PCA[6]	PCA[5]	PCA[4]	PCA[3]	PCA[2]	PCA[1]	PCA[0]	0000 0000
Bit 7~0: PCA[7~0] : Port-A directional bits 1 = Output mode 0 = Input mode											

10.2.3 Dynamic input buffers of Port-A

When Port-A is used as keyboard return lines and one key is pressed, the LCD segment waveform will input to Port-A and then be affected by the input buffer of Port-A. Setting control bit of PAK may enable the dynamic input buffer of the related input pin and thus lower the effect on display quality. The dynamic input buffer is enabled only when the LCD keyboard awaking pulses exist, that is, LCTL[7]=0 LCTL[4]=1.

Otherwise setting of PAK will be ignored, and the dynamic input buffer will be off.

Note: The dynamic input buffer can not pass the real value appears at input pin. It must be off when reading Port-A.

TABLE 10-4 Port-A used as keyboard return line selection

Address	Name	R/W	Bit 7	Bit 6	Bit 5	Bit 4	Bit 3	Bit 2	Bit 1	Bit 0	Default
\$00E	PAK	R/W	PAK[7]	PAK[6]	PAK[5]	PAK[4]	PAK[3]	PAK[2]	PAK[1]	PAK[0]	0000 0000
Bit 7~0: PAK[7~0] : 1 = Port-A used as keyboard return line. 0 = Port-A used as keyboard normal I/O.											

10.2.4 Port-A Pull-Up Option

Port-A contains PMOS transistors of pull-up resistor controlled by software in bit-manner. In case of input direction, on/off of the pull-up PMOS transistor is controlled by the data wrote to data register, PA. "1" is for enable and "0" is for disable. Above all, whole pull-up control is by PULL bit of PMCR. Refer to FIGURE 10-1 for the block description.

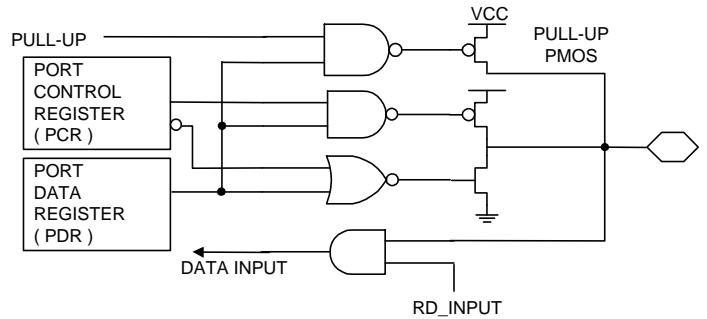

FIGURE 10-1 Port-A Block Diagram

TABLE 10-5 Port Function Control Register (PMCR)

Address	Name	R/W	Bit 7	Bit 6	Bit 5	Bit 4	Bit 3	Bit 2	Bit 1	Bit 0	Default
\$00F	PMCR	R/W	PULL	PDBN	INTEG	-	TEST	-	-	-	100 - 0 - -
<p>Bit 7: PULL : Enable all pull-up function bit 1 = Enable pull-up function 0 = Disable pull-up function</p> <p>Bit 6: PDBN : Enable Port-A interrupt de-bounce bit 1 = De-bounce for Port-A interrupt 0 = No de-bounce for Port-A interrupt</p> <p>Bit 5: INTEG : INTX interrupt edge option bit 1 = Rising edge 0 = Falling edge</p> <p>Bit3: TEST : Test bit, must be "0"</p>											

10.2.5 Port-A Interrupt

Port-A is suitable for the return line inputs of keyboard scan because of the port transition interrupt function. Difference between current value and the data kept previously of Port-A will generate an interrupt request. The last state of Port-A must be latched before transition, and this can be done by one read

Operate Port-A interrupt steps:

1. Set input mode.
2. Read Port-A.
3. Clear interrupt request flag (IRPT).
4. Set interrupt enable flag (IEPT).
5. Clear CPU interrupt disable flag (I).
6. Read Port-A before 'RTI' instruction in ISR.

instruction to Port-A. If both INTX and PT interrupts are enabled, signal edge of PA0 may trigger PT interrupt as well as INTX. Steps and program example are shown below. Also refer to FIGURE 10-2 for the block diagram.

Example:

```

.
.
STZ <PCA           ; Set input mode.
LDA  #$FF
STA  <PA           ; PA be PULL-UP.
LDA  <PA           ; Keep last state.
RMB4 <IREQ        ; Clear IRQ flag.
SMB4 <IENA        ; Enable INT.
CLI
.
.

```

Interrupt subroutine

```

.
.
LDA  <PA           ; Keep last state.
RTI

```

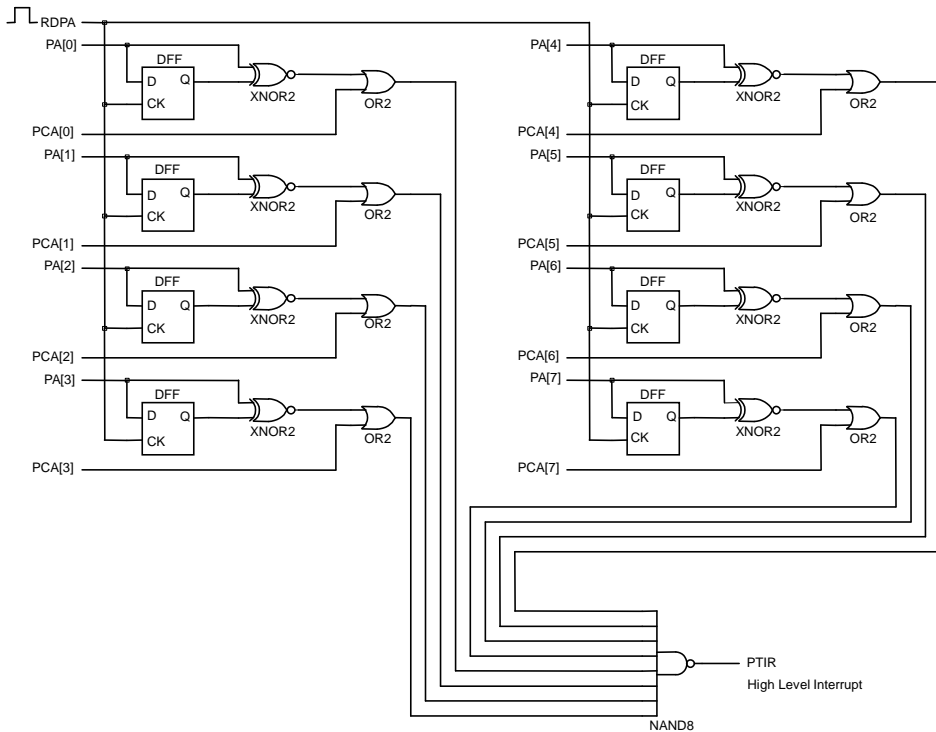

FIGURE 10-2 Port Interrupt Logic Diagram

10.2.6 Port-A Interrupt De-bounce

ST20P64 has hardware de-bounce block for Port-A interrupt. It is enabled with "1" and disable with "0" of PDBN(PMCR[6]). The de-bounce function is activated by Port-A transition. It uses

OSC_X as the sampling clock. The de-bounce time is **OSC_X x 512 cycles (about 16 ms)**. Data filtered by de-bounce presents a stable state, then the interrupt can be issued.

TABLE 10-6 Port Function Control Register (PMCR)

Address	Name	R/W	Bit 7	Bit 6	Bit 5	Bit 4	Bit 3	Bit 2	Bit 1	Bit 0	Default
\$00F	PMCR	R/W	PULL	PDBN	INTEG	-	TEST	-	-	-	100 - -0 - -
Bit 6: PDBN : Enable Port-A interrupt de-bounce bit 1 = De-bounce for Port-A interrupt 0 = No de-bounce for Port-A interrupt											

10.2.7 PA0/INTX

PA0 plays another function of external edge-sensitive interrupt source. Falling or rising edge is controlled by INTEG(PMCR[5]). Please refer to FIGURE 10-3. If both INTX and PT interrupts

are enabled, signal edge of PA0 may trigger PT interrupt as well as INTX. Steps and program example are shown below.

Steps for INTX interrupt operation:

1. Set PA0 to input mode. (PCA[0])
2. Select edge level. (INTEG)
3. Clear INTX interrupt request flag. (IRX)
4. Set INTX interrupt enable bits. (IEX)
5. Clear CPU interrupt mask flag (I).

Example:

```

:
:
RMB0 <PCA           ; Set input mode.
SMB5 <PMCR          ; Rising edge.
RMB0 <IREQ          ; Clear IRQ flag.
SMB0 <IENA          ; Enable INTX interrupt.
CLI
:
:
    
```

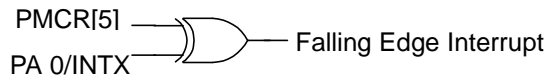

FIGURE 10-3 INTX Logic Diagram

10.3 Port-B and Port-C

10.3.1 General Description

Port-B and Port-C are bit-programmable bi-direction I/O ports, controlled by PCB and PCC registers. There is also bit programmable pull-up resistor for each input pin. All of the 16 I/Os can change into LCD segment drives. Control register

LSEL specifies which of these I/Os are LCD drives(Please refer to TABLE 15-2LCD Segment Number Selection Register (LSEL)).

TABLE 10-7 Summary of Port-B AND Port-C Registers

Address	Name	R/W	Bit 7	Bit 6	Bit 5	Bit 4	Bit 3	Bit 2	Bit 1	Bit 0	Default
\$001	PB	R/W	PB[7]	PB[6]	PB[5]	PB[4]	PB[3]	PB[2]	PB[1]	PB[0]	1111 1111
\$002	PC	R/W	PC[7]	PC[6]	PC[5]	PC[4]	PC[3]	PC[2]	PC[1]	PC[0]	1111 1111
\$009	PCB	R/W	PCB[7]	PCB[6]	PCB[5]	PCB[4]	PCB[3]	PCB[2]	PCB[1]	PCB[0]	0000 0000
\$00A	PCC	R/W	PCC[7]	PCC[6]	PCC[5]	PCC[4]	PCC[3]	PCC[2]	PCC[1]	PCC[0]	0000 0000
\$00F	PMCR	R/W	PULL	PDBN	INTEG	-	TEST	-	-	-	100 - - - -
\$039	LSEL	R/W	-	-	-	LSEL[4]	LSEL[3]	LSEL[2]	LSEL[1]	LSEL[0]	- - - 1 1111

10.3.2 Input/Output Control

PCB/PCC controls the I/O direction of Port-B/C. Each bit of PCB[7~0]/PCC[7~0] controls the direction of one single bit of

Port-B/C respectively, with “1” for output mode, and “0” for input mode.

TABLE 10-8 PORT-B Control Register (PCB)

Address	Name	R/W	Bit 7	Bit 6	Bit 5	Bit 4	Bit 3	Bit 2	Bit 1	Bit 0	Default
\$009	PCB	R/W	PCB[7]	PCB[6]	PCB[5]	PCB[4]	PCB[3]	PCB[2]	PCB[1]	PCB[0]	0000 0000
Bit 7~0: PCB[7~0] : Port-B directional bits 1 = Output mode 0 = Input mode											

TABLE 10-9 PORT-C Control Register (PCC)

Address	Name	R/W	Bit 7	Bit 6	Bit 5	Bit 4	Bit 3	Bit 2	Bit 1	Bit 0	Default
\$00A	PCC	R/W	PCC[7]	PCC[6]	PCC[5]	PCC[4]	PCC[3]	PCC[2]	PCC[1]	PCC[0]	0000 0000
Bit 7~0: PCC[7~0] : Port-C directional bits 1 = Output mode 0 = Input mode											

10.3.3 PORT-B and PORT-C PULL-UP OPTION

Port-B/C contains PMOS transistors of pull-up resistor controlled by software in bit-manner. In case of input direction, on/off of the pull-up PMOS transistor is controlled by the data wrote to data register, PB/PC. "1" is for enable and "0" is for disable. Above all, whole pull-up control is by PULL bit of PMCR. Refer to FIGURE 10-4 for the block description.

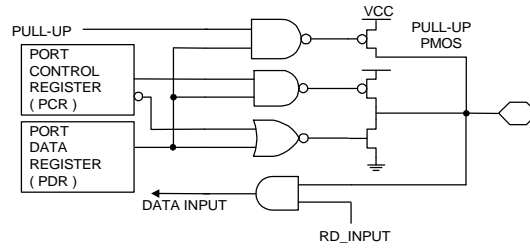

FIGURE 10-4 Port-B and Port-C Block Diagram

TABLE 10-10 Port Control Register (PMCR)

Address	Name	R/W	Bit 7	Bit 6	Bit 5	Bit 4	Bit 3	Bit 2	Bit 1	Bit 0	Default
\$00F	PMCR	R/W	PULL	PDBN	INTEG	-	TEST	-	-	-	100 - - - - -
Bit 7: PULL : Enable all pull-up functions bit 1 = Enable pull-up function 0 = Disable pull-up function											

10.4 COMMON-PORT

The COM15~COM8 can be used as LCD drivers or output ports. In output port mode, COM[7~0] will be map to COM15~COM8 output ports, which pin assignment will be

decided by DUTY[1:0] of \$39(LSEL), Please refer to the following table.

TABLE 10-11 LCD Segment Number Selection Register (LSEL)

Address	Name	R/W	Bit 7	Bit 6	Bit 5	Bit 4	Bit 3	Bit 2	Bit 1	Bit 0	Default
\$039	LSEL	R/W	DUTY[1]	DUTY[0]	BIAS4	LSEL[4]	LSEL[3]	LSEL[2]	LSEL[1]	LSEL[0]	0001 1111
<p>Bit 5: DUTY : Common output selection bit 0X = 1/16 duty and COM15~COM8 used as LCD Common pins 10 = 1/12 duty and COM15~COM12 used as output pins 11 = 1/8 duty and COM15~COM8 used as output pins</p>											

TABLE 10-12 COM Output Register (COM)

Address	Name	R/W	Bit 7	Bit 6	Bit 5	Bit 4	Bit 3	Bit 2	Bit 1	Bit 0	Default
\$036	COM	R/W	COM[7]	COM[6]	COM[5]	COM[4]	COM[3]	COM[2]	COM[1]	COM[0]	???? ????
<p>Bit 7: COM[7] : COM15 scan output bit 1 = COM15 output =FLOATING 0 = COM15 output =LOW</p> <p>Bit 6: COM[6] : COM14 scan output bit 1 = COM14 output =FLOATING 0 = COM14 output =LOW</p> <p>Bit 5: COM[5] : COM13 scan output bit 1 = COM13 output =FLOATING 0 = COM13 output =LOW</p> <p>Bit 4: COM[4] : COM12 scan output bit 1 = COM12 output =FLOATING 0 = COM12 output =LOW</p> <p>Bit 3: COM[3] : COM11 scan output bit 1 = COM11 output =FLOATING 0 = COM11 output =LOW</p> <p>Bit 2: COM[2] : COM10 scan output bit 1 = COM10 output =FLOATING 0 = COM10 output =LOW</p> <p>Bit 1: COM[1] : COM9 scan output bit 1 = COM9 output =FLOATING 0 = COM9 output =LOW</p> <p>Bit 0: COM[0] : COM8 scan output bit 1 = COM8 output =FLOATING 0 = COM8 output =LOW</p>											

11. OSCILLATOR

ST20P64 has dual clock sources, OSC (RC) and OSCX (32768Hz crystal). The system clock (SYSCK) can be switched between OSC and OSCX, and is controlled by XSEL (SYS[7]). When system clock is switched, the warm-up cycles occur at the same time. Clock source being used is shown at

XSEL (read). Read and test XSEL to confirm SYSCK is already switched over. Other blocks, such as LCD controller, Timer1, Base Timer and PSG, can utilize these two clock sources as well.

TABLE 11-1 System Control Register (SYS)

Address	Name	R/W	Bit 7	Bit 6	Bit 5	Bit 4	Bit 3	Bit 2	Bit 1	Bit 0	Default
\$030	SYS	R/W	XSEL	OSTP	XSTP	TEST	WSKP	WAIT	-	LVDET	0000 00-0

Bit 7: **XSEL** : System clock (SYSCK) select (write) / confirm (read) bit
 1 = OSCX
 0 = OSC

Bit 6: **OSTP** : OSC stop control bit
 1 = Disable OSC
 0 = Enable OSC

Bit 5: **XSTP** : OSCX stop control bit
 1 = Disable OSCX
 0 = Enable OSCX

Bit 4: **TEST** : Test bit, must be "0"

Note:

1. XSEL (SYS[7]) shows which clock source is used for SYSCK when it is read.
2. System warm-up of 16 or 256 oscillation cycles occurs when system clock (SYSCK) is changed or power on reset.

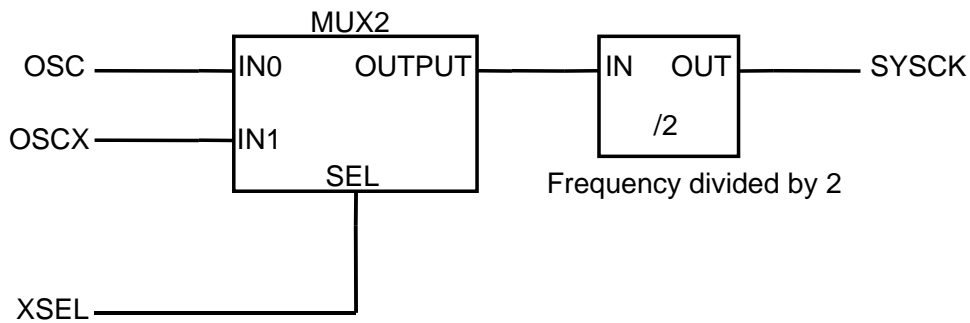

FIGURE 11-1 System Clock Diagram

12. TIMER/EVENT COUNTER

12.1 Prescaler

12.1.1 Function Description

The ST20P64 has three timers, Base timer, Timer 0 and Timer 1, and two prescalers PRES and PREW. There are two clock

sources, SYSCK and INTX, for PRES and one clock source, OSCX, for PREW. Refer to FIGURE 12-1

TABLE 12-1 Summary of Timer Registers

Address	Name	R/W	Bit 7	Bit 6	Bit 5	Bit 4	Bit 3	Bit 2	Bit 1	Bit 0	Default
\$021	BTM	W	-	-	-	-	BTM[3]	BTM[2]	BTM[1]	BTM[0]	---- 0000
\$023	PRS	R	PRS[7]	PRS[6]	PRS[5]	PRS[4]	PRS[3]	PRS[2]	PRS[1]	PRS[0]	0000 0000
		W	SRES	SENA	SENT	-	-	-	-	-	-
\$024	T0M	R/W	-	-	T0M[5]	T0M[4]	-	T0M[2]	T0M[1]	T0M[0]	- - 00 - 000
\$025	T0C	R/W	T0C[7]	T0C[6]	T0C[5]	T0C[4]	T0C[3]	T0C[2]	T0C[1]	T0C[0]	0000 0000
\$026	T1M	R/W	-	-	-	T1M[4]	T1M[3]	T1M[2]	T1M[1]	T1M[0]	- - - 0 0000
\$027	T1C	R/W	T1C[7]	T1C[6]	T1C[5]	T1C[4]	T1C[3]	T1C[2]	T1C[1]	T1C[0]	0000 0000
\$030	SYS	R/W	XSEL	OSTP	XSTP	TEST	WSKP	WAIT	-	-	0000 00- -
\$03C	IREQ	R/W	-	-	IRBT	IRPT	IRT1	IRT0	IRDAC	IRX	- - 00 0000
\$03E	IENA	R/W	-	-	IEBT	IEPT	IET1	IET0	IEDAC	IEX	- - 00 0000

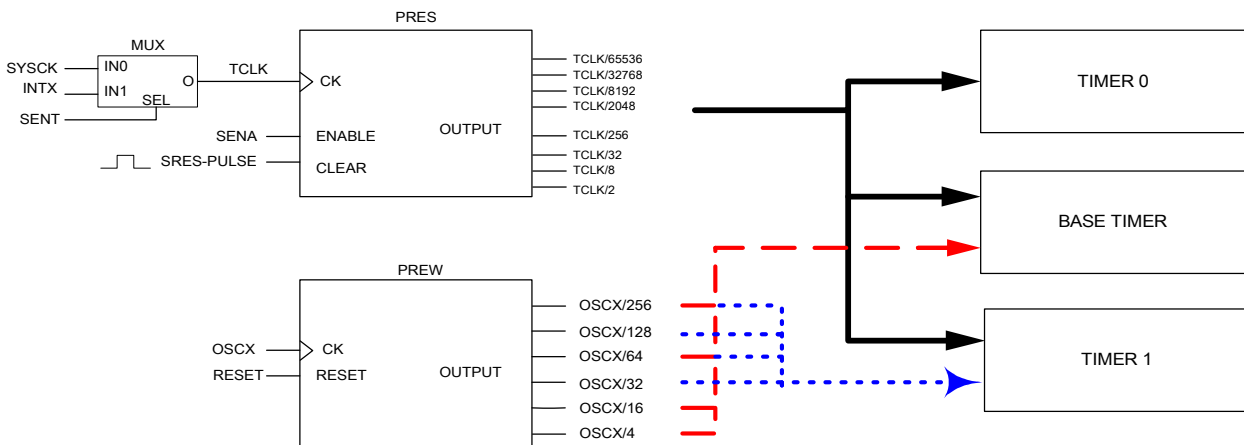

FIGURE 12-1 Structure Of Two Prescalers

12.1.2 PRES

The prescaler PRES is an 16-bits counter as shown in FIGURE 12-1. Which provides four clock sources for base timer and timer1, and it is controlled by register PRS. The instruction read toward PRS will bring out the content of PRES and the

Instruction write toward PRS will reset, enable or select clock sources for PRES.

When user set external interrupt as the input of PRES for event counter, combining PRES and Timer1 will get a 16bit-event counter.

TABLE 12-2 Prescaler Control Register (PRS)

Address	Name	R/W	Bit 7	Bit 6	Bit 5	Bit 4	Bit 3	Bit 2	Bit 1	Bit 0	Default
\$023	PRS	R	PRS[7]	PRS[6]	PRS[5]	PRS[4]	PRS[3]	PRS[2]	PRS[1]	PRS[0]	0000 0000
		W	SRES	SENA	SENT	-	-	-	-	-	000 - - - - -

READ
Bit 7~0: **PRS[7~0]** : The low byte value of PRES counter

WRITE

Bit 7: **SRES** : Prescaler Reset bit
Write "1" to reset the prescaler (PRS[7~0])

Bit 6: **SENA** : Prescaler enable bit
0 = Disable prescaler counting
1 = Enable prescaler counting

Bit 5: **SENT** : Clock source(TCLK) selection for prescaler PRES
0 = Clock source from system clock "SYSCK"
1 = Clock source from external events "INTX"

12.1.3 PREW

The prescaler PREW is an 8-bits counter as shown in FIGURE 12-1. PREW provides four clocks source for base timer and

timer1. It stops counting only if OSCX stops or hardware reset occurs.

12.2 Base timer

12.2.1 Function Description

Base timer is an 8-bit up counting timer. When it overflows from \$FF to \$00, a timer interrupt request IRBT will be generated.

Please refer to FIGURE 12-2

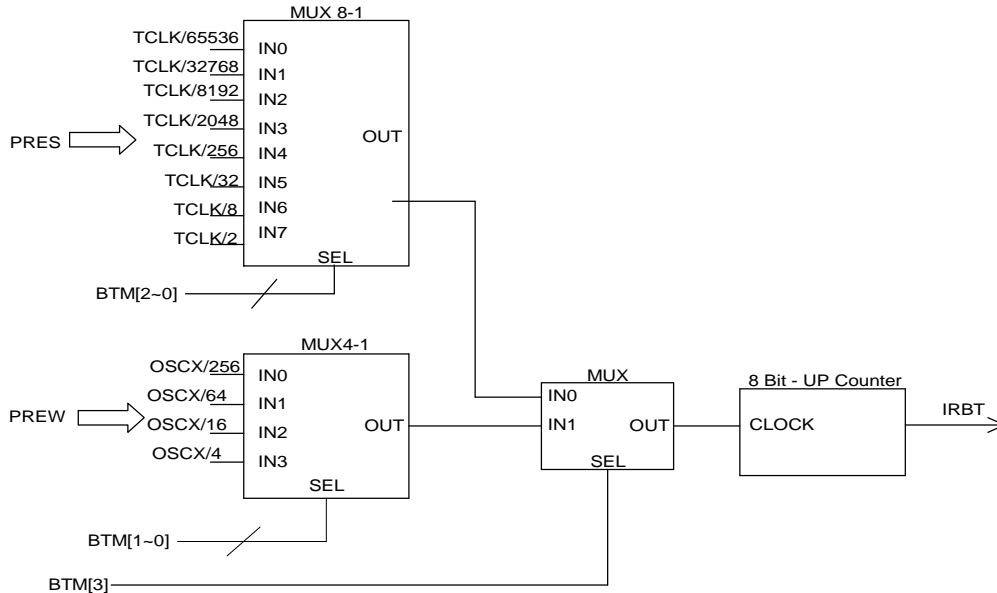

FIGURE 12-2 Structure Of Base Timer

12.2.2 Base Timer Clock Source Control

Several clock sources can be selected for Base Timer. Please refer to TABLE 12-3

TABLE 12-3 Clock Sources Of Base Timer

* SENA	BTM[3]	BTM[2]	BTM[1]	BTM[0]	Base Timer source clock
0	X	X	X	X	STOP
1	0	0	0	0	TCLK / 65536
1	0	0	0	1	TCLK / 32768
1	0	0	1	0	TCLK / 8192
1	0	0	1	1	TCLK / 2048
1	0	1	0	0	TCLK / 256
1	0	1	0	1	TCLK / 32
1	0	1	1	0	TCLK / 8
1	0	1	1	1	TCLK / 2
X	1	0	0	0	OSCX / 256
X	1	0	0	1	OSCX / 64
X	1	0	1	0	OSCX / 16
X	1	0	1	1	OSCX / 4

Note: TCLK will stop when an '0' is written to SENA (PRS[6]).

12.3 Timer 0

12.3.1 Function Description

The Timer0 is an 8-bit up counter. It can be used as a timer or an event counter. T0C(\$25) is a real time read/write counter. When an overflow from \$FF to \$00, a timer interrupt request IRT0 will

be generated. Timer0 will stop counting when system clock stops. Please refer to FIGURE 12-3.

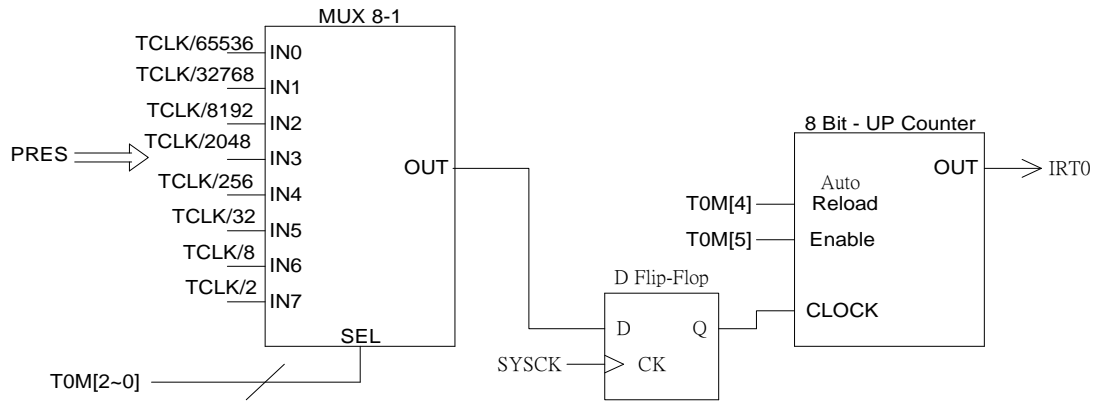

FIGURE 12-3 Timer0 Structure

12.3.2 Timer0 Clock Source Control

Several clock sources can be chosen from for Timer0. It's very important that Timer0 can keep counting as long as SYSCK stays active. Refer to TABLE 12-4.

TABLE 12-4 Clock Sources Of Timer0

T0M[2]	T0M[1]	T0M[0]	T0 Timer Clock Source
0	0	0	TCLK/65536
0	0	1	TCLK/32768
0	1	0	TCLK/8192
0	1	1	TCLK/2048
1	0	0	TCLK/256
1	0	1	TCLK/32
1	1	0	TCLK/8
1	1	1	TCLK/2

T0M[4] : Control automatic reload operation

- 0 : No auto reload
- 1 : Auto reload

T0M[5] : Control Timer 0 enable/disable

- 0 : Disable counting
- 1 : Enable counting

SENA : Prescaler enable bit

- 0 : TCLK stop
- 1 : TCLK counting

TABLE 12-5 Timer0 Register (T0C)

Address	Name	R/W	Bit 7	Bit 6	Bit 5	Bit 4	Bit 3	Bit 2	Bit 1	Bit 0	Default
\$025	T0C	R/W	T0C[7]	T0C[6]	T0C[5]	T0C[4]	T0C[3]	T0C[2]	T0C[1]	T0C[0]	0000 0000
Bit 7-0: T0C[7-0] : Timer0 up counter register											

12.4 Timer 1

The Timer1 is an 8-bit up counter. It used as timer/counter as program specified. The difference between base timer is that Timer1 will halt during CPU SBY, but base timer will not. It is shown in FIGURE 12-4.

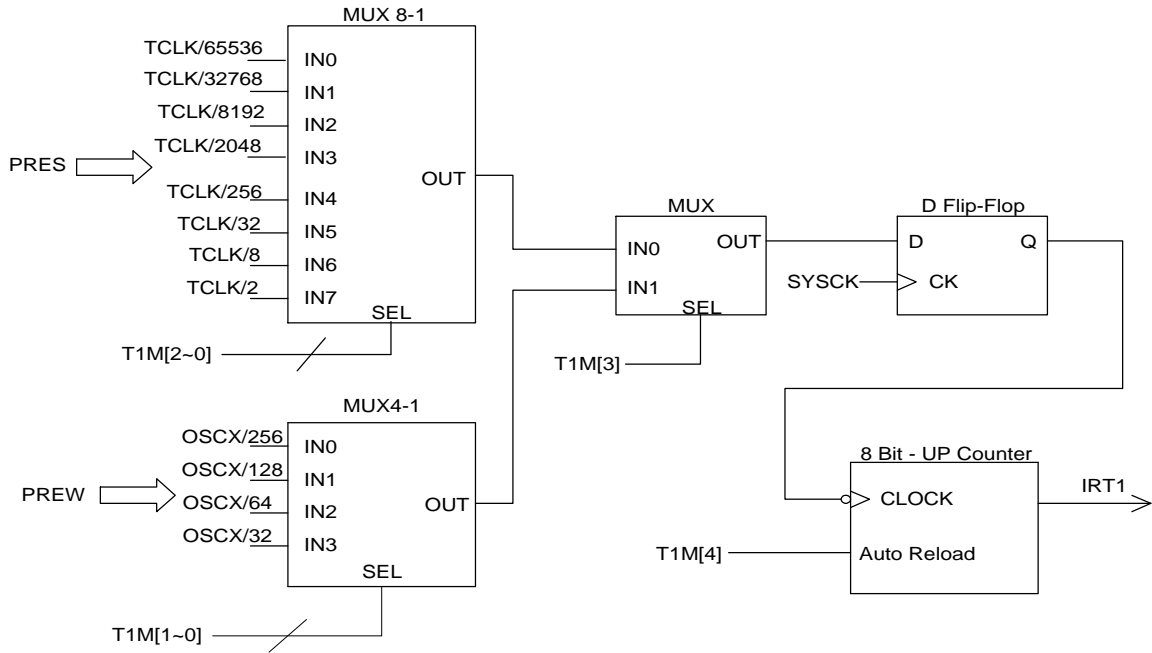

FIGURE 12-4 Timer1 Structure

TABLE 12-6 Timer1 Register (T1C)

Address	Name	R/W	Bit 7	Bit 6	Bit 5	Bit 4	Bit 3	Bit 2	Bit 1	Bit 0	Default
\$027	T1C	R/W	T1C[7]	T1C[6]	T1C[5]	T1C[4]	T1C[3]	T1C[2]	T1C[1]	T1C[0]	0000 0000
Bit 7-0: T1C[7-0] : Timer1 up counter register											

TABLE 12-7 Clock Sources Of Timer1

T1M[3]	T1M[2]	T1M[1]	T1M[0]	T1 Timer Clock Source
0	0	0	0	TCLK/65536
0	0	0	1	TCLK/32768
0	0	1	0	TCLK/8192
0	0	1	1	TCLK/2048
0	1	0	0	TCLK/256
0	1	0	1	TCLK/32
0	1	1	0	TCLK/8
0	1	1	1	TCLK/2
1	0	0	0	OSCX/256
1	0	0	1	OSCX/128
1	0	1	0	OSCX/64
1	0	1	1	OSCX/32

T1M[4]: Control automatic reload operation

0: No auto reload

1: auto reload

SENA : Prescaler enable bit

0 : TCLK stop

1 : TCLK counting

13. PSG

13.1 Function description

The built-in dual channel Programmable Sound Generator (PSG) is controlled by registers. Its flexibility makes it useful in applications such as music synthesis, sound effects generation, audible alarms and tone signaling. In order to generate sound effects while allowing the processor to perform other tasks, the PSG can continue to produce sound after the initial commands have been given by the CPU. The structure of PSG was shown in FIGURE 13-2 and the PSG clock source is shown in

FIGURE 13-1. ST20P64 has three playing modes. First is that both channel0 (CH0) and channel1 (CH1) output square type tones. Second is CH0 outputs square tone, and CH1 outputs noise. Third mode is PWM DAC mode. Sounds of two channels are mixed into one signal and are outputted in the form of digital waveform from two pins, PSGOB/PSGO. Therefore one AC waveform can be performed.

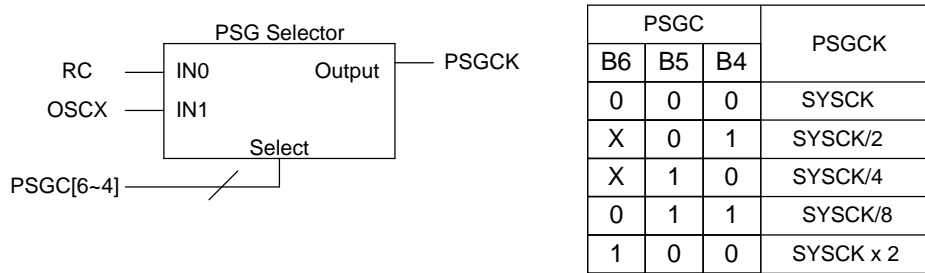

FIGURE 13-1 PSG Clock Source Control

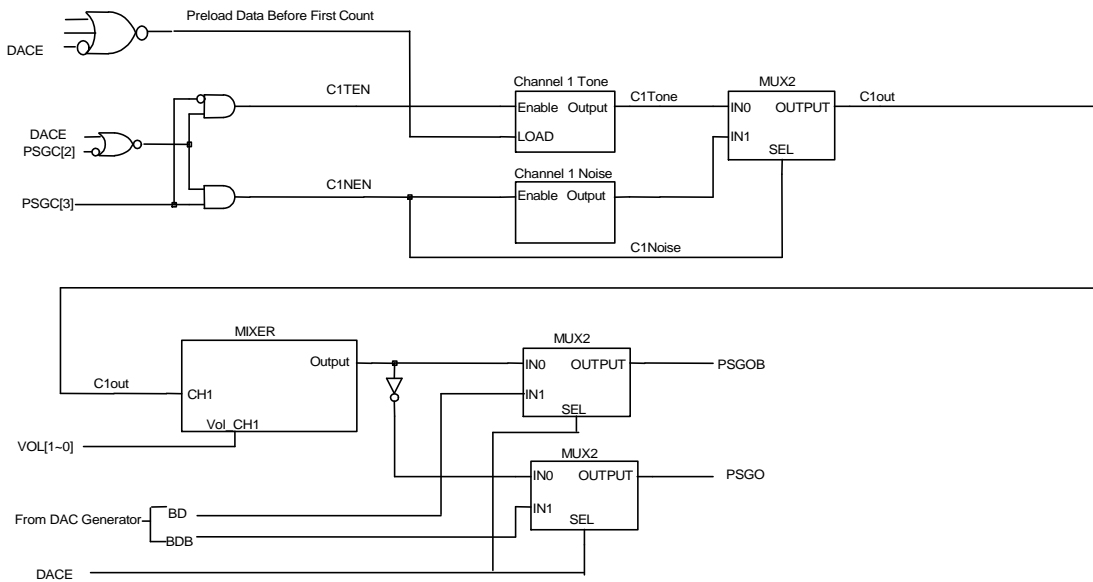

FIGURE 13-2 PSG Block Diagram

PS: In order to make sure the PSG function is working normally on the EV or Real Chip Board, Please connect PSG's power **PVCC** to VCC

TABLE 13-1 Summary Of PSG Registers

Address	Name	R/W	Bit 7	Bit 6	Bit 5	Bit 4	Bit 3	Bit 2	Bit 1	Bit 0	Default
\$010	PSG0L	W	PSG0[7]	PSG0[6]	PSG0[5]	PSG0[4]	PSG0[3]	PSG0[2]	PSG0[1]	PSG0[0]	0000 0000
\$011	PSG0H	W	-	-	-	-	PSG0[11]	PSG0[10]	PSG0[9]	PSG0[8]	---- 0000
\$012	PSG1L	W	PSG1[7]	PSG1[6]	PSG1[5]	PSG1[4]	PSG1[3]	PSG1[2]	PSG1[1]	PSG1[0]	0000 0000
\$013	PSG1H	W	-	-	-	-	PSG1[11]	PSG1[10]	PSG1[9]	PSG1[8]	---- 0000
\$015	PSGC2	R/W	-	-	-	-	PSGOD	PSGOBD	PSGOE	PSGOBE	---- 1111
\$016	PSGC	W	-	PCK[2]	PCK[1]	PCK[0]	PRBS	C1EN	C0EN	DACE=0	- 000 0000
		W	-	PCK[2]	PCK[1]	PCK[0]	DMD[1]	DMD[0]	INH	DACE=1	- 000 0000
\$017	VOL	W	VOL1[3]	VOL1[2]	VOL1[1]	VOL1[0]	VOL0[3]	VOL0[2]	VOL0[1]	VOL0[0]	0000 0000

TABLE 13-2 CONTROL REGISTER FOR PSG OUTPUT (PSGC2)

Address	Name	R/W	Bit 7	Bit 6	Bit 5	Bit 4	Bit 3	Bit 2	Bit 1	Bit 0	Default
\$015	PSGC2	R/W	-	-	-	-	PSGOD	PSGOBD	PSGOE	PSGOBE	---- 1111

Bit 3: **PSGOD** : Data bit if PSGO is used as normal output pin.
 1 = PSGO is output High.
 0 = PSGO is output Low

Bit 2: **PSGOBD** : Data bit if PSGOB is used as normal output pin.
 1 = PSGOB is output High.
 0 = PSGOB is output Low

Bit 1: **PSGOE** : PSG output enable bit
 1 = PSGO is PSG data output pin.
 0 = PSGO is normal output pin

Bit 0: **PSGOBE** : PSG inverse signal output enable bit
 1 = PSGOB is PSG inverse data output pin.
 0 = PSGOB is normal output pin

TABLE 13-3 PSG Volume Control Register (VOL)

Address	Name	R/W	Bit 7	Bit 6	Bit 5	Bit 4	Bit 3	Bit 2	Bit 1	Bit 0	Default
\$017	VOL	W	VOL1[3]	VOL1[2]	VOL1[1]	VOL1[0]	VOL0[3]	VOL0[2]	VOL0[1]	VOL0[0]	0000 0000

Bit 3~0: **VOL0[3~0]** : PSG channel 0 volume control bit
 0000 = No sound output
 0001 = 1/16 volume (PSGCK must >= 320K Hz)
 :
 0100 = 4/16 volume
 :
 1000 = 8/16 volume
 :
 1111 = Maximum volume (PSGCK must >= 20K Hz)

Bit 7~4: **VOL1[3~0]** : PSG channel 1 volume control bit
 0000 = No sound output
 0001 = 1/16 volume (PSGCK must >= 320K Hz)
 :
 0100 = 4/16 volume
 :
 1000 = 8/16 volume
 :
 1111 = Maximum volume (PSGCK must >= 20K Hz)

Note: If single channel is enable, then PSG volume control can be double. (16 + 16 = 32 level volume control)

13.2 Tone Generator

13.2.1 General Description

The tone frequency is decided by PSGCK and 12-bit programmable divider (PSG[11~0]). Please refer to

FIGURE 13-3 and FIGURE 13-4.

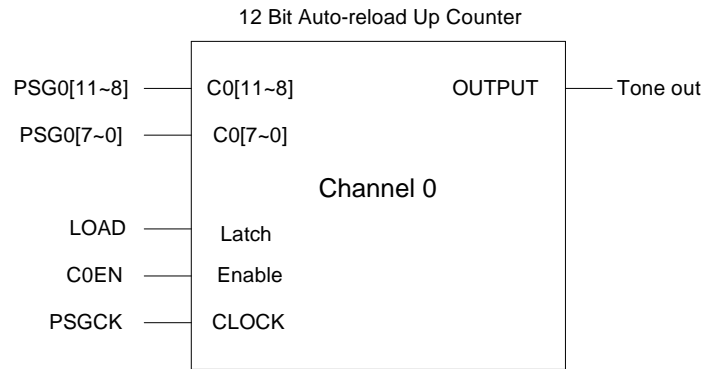

$$\text{Frequency of Channel 0 Tone} = \text{PSGCK} / ((1000\text{H-PCH0}[11\sim0]) / 2)$$

FIGURE 13-3 Tone Generator Channel 0

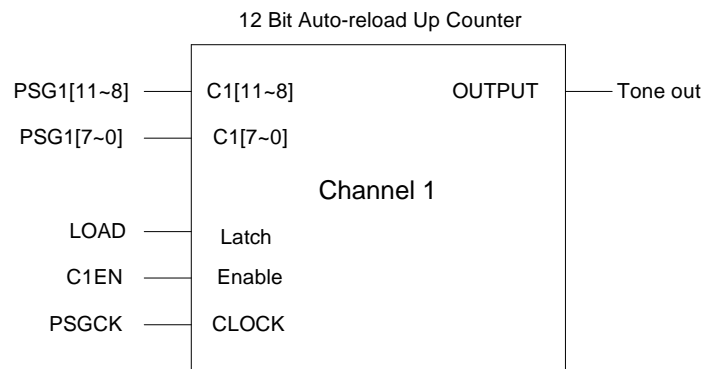

$$\text{Frequency of Channel 1 Tone} = \text{PSGCK} / ((1000\text{H-PCH1}[11\sim0]) / 2)$$

FIGURE 13-4 Tone Generator Channel 1

13.2.2 PSG Tone Programming

Tone or DAC function is defined by register DACE. Write to C1EN will enable tone generator when PSG is in tone

function. Noise or tone function is selected by PRBS.

TABLE 13-4 PSG Control Register (PSGC)

Address	Name	R/W	Bit 7	Bit 6	Bit 5	Bit 4	Bit 3	Bit 2	Bit 1	Bit 0	Default
\$016	PSGC	W	-	PCK[2]	PCK[1]	PCK[0]	PRBS	C1EN	C0EN	DACE=0	- 000 0000
		W	-	PCK[2]	PCK[1]	PCK[0]	DMD[1]	DMD[0]	INH	DACE=1	- 000 0000
<p>Bit 0: DACE : Tone(Noise) or DAC Generator selection bit 1 = PSG is used as the DAC generator 0 = PSG is used as the Tone (Noise) generator</p> <p>Bit 1: C0EN : PSG channel 0 (Tone) enable bit 1 = PSG0 (Tone) enable 0 = PSG0 (Tone) disable</p> <p>Bit 2: C1EN : PSG channel 1 (Tone or Noise) enable bit 1 = PSG1 (Tone or Noise) enable 0 = PSG1 (Tone or Noise) disable</p> <p>Bit 3: PRBS : Tone or Noise generator selection bit 1 = Noise generator 0 = Tone generator</p> <p>Bit 6-4: PCK[2-0] : clock source selection for PSG and DAC 000 = SYSCK X01 = SYSCK / 2 X10 = SYSCK / 4 011 = SYSCK / 8 100 = SYSCK x 2</p>											

13.3 Noise Generator Control

13.3.1 General description

Noise generator is shown in FIGURE 13-5, which base frequency is controlled by PSG1[5~0]

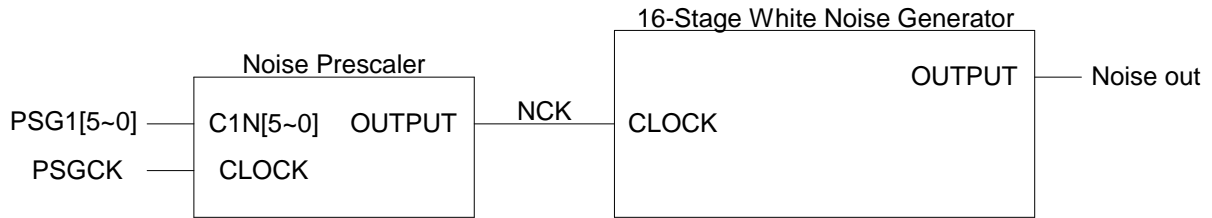

$$NCK \text{ Frequency} = \text{PSGCK} / (40H\text{-PCH1}[5\sim 0])$$

FIGURE 13-5 Noise Generator

13.3.2 Noise Generator Programming

DACE defines noise or DAC function. Writing a "1" to C1EN will enable noise generator when PSG is in noise mode

13.4 PSG Application Circuit

Sounds of two channels are modulated by PSGCK and combine together into one AC signal. Then it outputs on

PSGOB and PSGO. Positive part of the AC signal is output from PSGO while the negative part is from PSGOB.

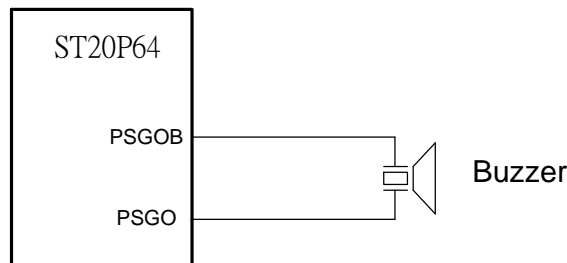

FIGURE 13-6 PSG application circuit

14. PWM DAC

14.1 Function description

A built-in PWM DAC is for analog sampling data or voice signals. The structure of DAC is shown in TABLE 14-1. There is an interrupt signal from DAC to CPU whenever

DAC data update is needed and the same signal will decide the sampling rate of voice. In DAC mode, the frequency of RC oscillator can't be less than 2M Hz.

TABLE 14-1 Summary Of DAC Registers

Address	Name	R/W	Bit 7	Bit 6	Bit 5	Bit 4	Bit 3	Bit 2	Bit 1	Bit 0	Default
\$012	PSG1L	W	PSG1[7]	PSG1[6]	PSG1[5]	PSG1[4]	PSG1[3]	PSG1[2]	PSG1[1]	PSG1[0]	00000000
\$013	PSG1H	W	-	-	-	-	PSG1[11]	PSG1[10]	PSG1[9]	PSG1[8]	- - - - 0000
\$014	DAC	W	DAC[7]	DAC[6]	DAC[5]	DAC[4]	DAC[3]	DAC[2]	DAC[1]	DAC[0]	00000000
\$016	PSGC	W	-	PCK[2]	PCK[1]	PCK[0]	PRBS	C1EN	COEN	DACE=0	- 00000 - 0
		W	-	PCK[2]	PCK[1]	PCK[0]	DMD[1]	DMD[0]	INH	DACE=1	- 0000000

TABLE 14-2 DAC Data Register (DAC)

Address	Name	R/W	Bit 7	Bit 6	Bit 5	Bit 4	Bit 3	Bit 2	Bit 1	Bit 0	Default
\$014	DAC	W	DAC[7]	DAC[6]	DAC[5]	DAC[4]	DAC[3]	DAC[2]	DAC[1]	DAC[0]	0000 0000

Bit 7~0: **DAC[7~0]** : DAC output data

Note: For Single-Pin Single Ended mode, the effective output resolution is 7 bit.

TABLE 14-3 DAC Control Register (PSGC)

Address	Name	R/W	Bit 7	Bit 6	Bit 5	Bit 4	Bit 3	Bit 2	Bit 1	Bit 0	Default
\$016	PSGC	W	-	PCK[2]	PCK[1]	PCK[0]	PRBS	C1EN	COEN	DACE=0	- 000 00-0
		W	-	PCK[2]	PCK[1]	PCK[0]	DMD[1]	DMD[0]	INH	DACE=1	- 000 0000

Bit 0: **DACE** : PSG play as Tone (Noise) or DAC Generator selection bit
 1 = PSG is used as DAC Generator
 0 = PSG is used as Tone (Noise) Generator

Bit 1: **INH** : DAC output inhibit control bit
 1 = DAC output inhibit
 0 = DAC output enable

Bit 3~2: **DMD[1~0]** : DAC output mode selection
 00 = Single-Pin mode : 7 bit resolution
 01 = Two-Pin Two Ended mode : 8 bit resolution
 10 = Reserved
 11 = Two-Pin Push Pull mode : 8 bit resolution

Bit 6~4: **PCK[2~0]** : PSGCK selection for PSG and DAC
 000 = SYSCK
 X01 = SYSCK / 2
 X10 = SYSCK / 4
 011 = SYSCK / 8
 100 = SYSCK x 2 (= frequency of RC oscillator)

Note: In DAC mode, PSGCK must select SYSCK x 2 (PCK[2~0]=100) under RC=2MHz.

14.2 Sample Rate Control

PSG1L and PSG1H control the sample rate. PSG1[11~6] controls PWM repeat times (usually set=111100 for four times of DAC reload) and PSG1[5~0] usually set '1'. The

input clock source is controlled by PCK[2~0]. The block diagram is shown as the following:

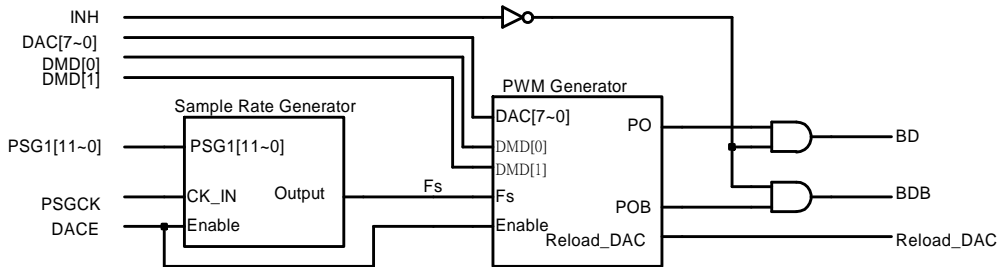

FIGURE 14-1 DAC Diagram

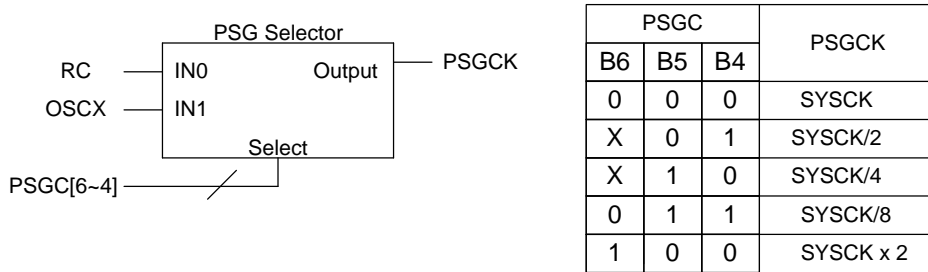

FIGURE 14-2 DAC Clock Source Control

TABLE 14-4 DAC Sample Rate Description (RCosc = 2MHz)

DAC interrupt frequency	PSGC b6, b5, b4	PSG1H, PSG1L
8K	100	00001111, 00111111
16K	100	00001111, 10111111

14.3 PWM DAC Mode Options

The PWM DAC generator has three modes, Single-pin mode, Two-pin two-ended mode and Two-pin push pull

mode. They are depended on the application used. The DAC mode is controlled by DMD[1~0]. (TABLE 13-3)

14.3.1 Single-Pin Mode (7-bit Accuracy)

Single-pin mode is designed for use with a single-transistor amplifier. It has 7 bits of resolution. The duty cycle of the PSGO is proportional to the output value. If the output value is 0, the duty cycle is 50%. As the output value increases from 0 to 63, the duty cycle goes from being high 50% of

the time up to 100% high. As the value goes from 0 to -64, the duty cycle decreases from 50% high to 0%. PSGOB is inverse of PSGO's waveform. Figure 13-3 shows the PSGO waveforms.

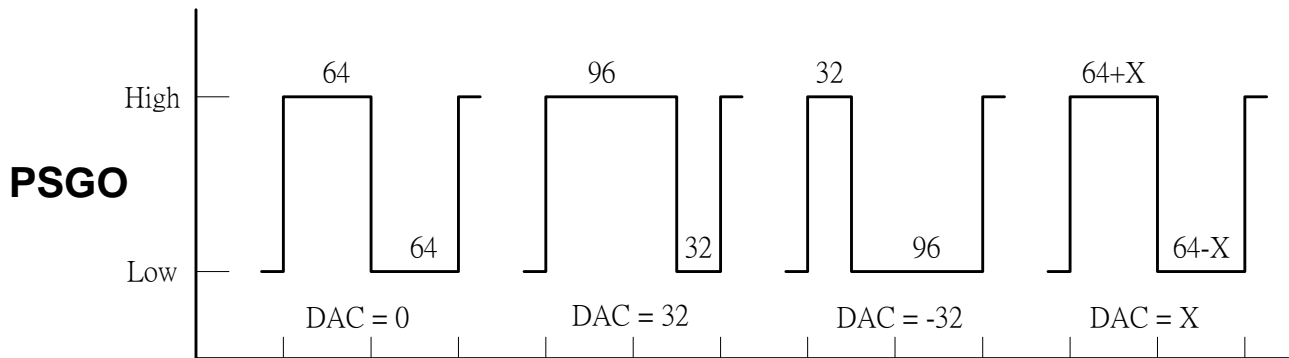

FIGURE 14-3 Single-Pin Mode Wave Form

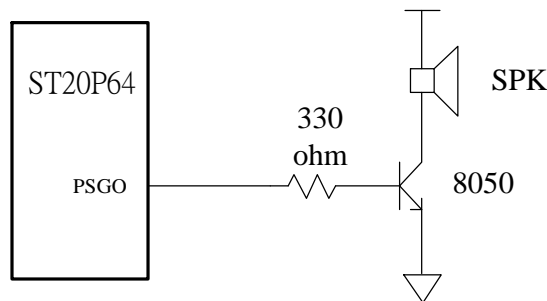

FIGURE 14-4 Single-Pin Mode Application Circuit

14.3.2 Two-Pin Two Ended Mode (8-bit Accuracy)

Two-Pin Two-Ended mode is designed for use with a single transistor amplifier. It requires two pin that PSGO and PSGOB. When the DAC value is positive, PSGO goes high with a duty cycle proportional to the output value, while PSGOB stays high. When the DAC value is negative, PSGOB goes low with a duty cycle proportional to the output value, while PSGO stays low. This mode offers a resolution of 8 bits.

Figure 13-5 shows examples of DAC output waveforms with different output values. Each pulse of the DAC is divided into 128 segments per sample period. For a positive output value $x=0$ to 127, PSGO goes high for X segments while PSGOB stays high. For a negative output value $x=0$ to -127, PSGOB goes low for $|X|$ segments while PSGO stays low.

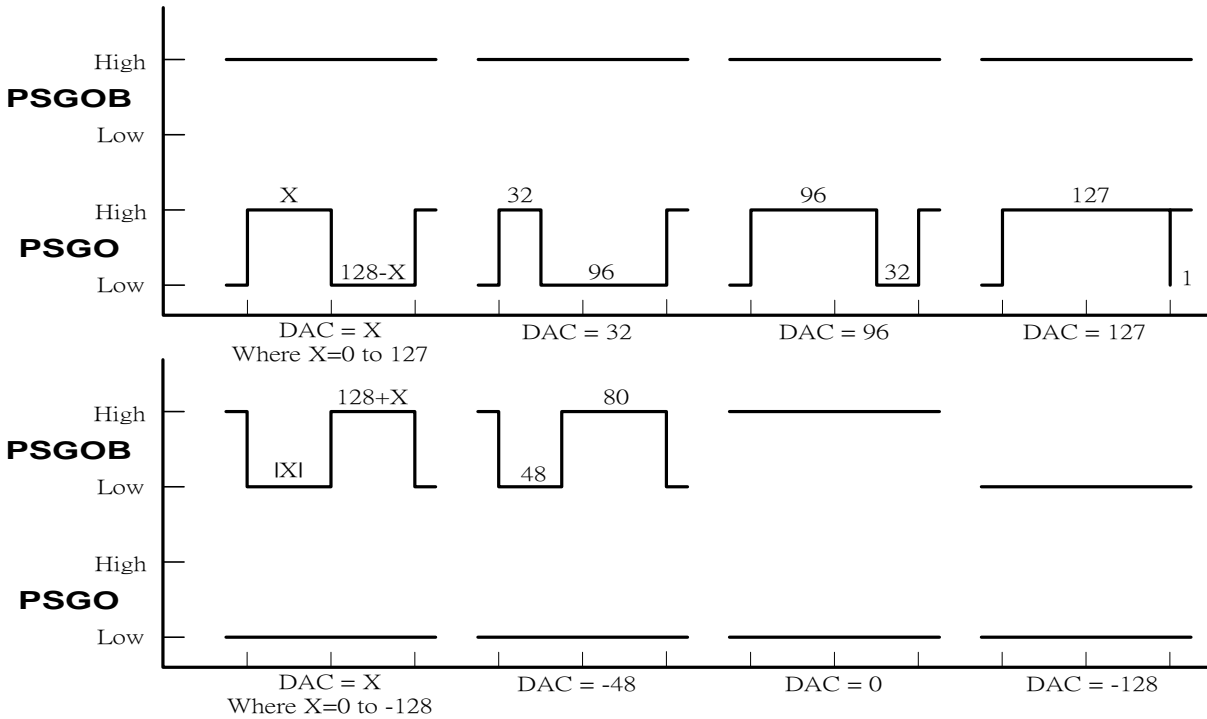

FIGURE 14-5 Two-Pin Two Ended Mode Wave-Form

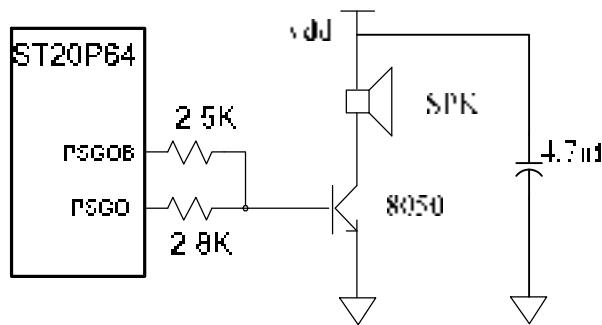

FIGURE 14-6 Two-Pin Two Ended Mode Application Circuit

14.3.3 Two-Pin Push Pull Mode (8-bit Accuracy)

Two-Pin Push Pull mode is designed for buzzer. It requires two pin that PSGO and PSGOB. When the DAC value is 0, both pins are low. When the DAC value is positive, PSGO goes high with a duty cycle proportional to the output value, while PSGOB stays low. When the DAC value is negative, PSGOB goes high with a duty cycle proportional to the output value, while PSGO stays low. This mode offers a resolution of 8 bits.

Figure 13-7 shows examples of DAC output waveforms with different output values. Each pulse of the DAC is divided into 128 segments per sample period. For a positive output value $x=0$ to 127, PSGO goes high for X segments while PSGOB stays low. For a negative output value $x=0$ to -127, PSGOB goes high for $|X|$ segments while PSGO stays low.

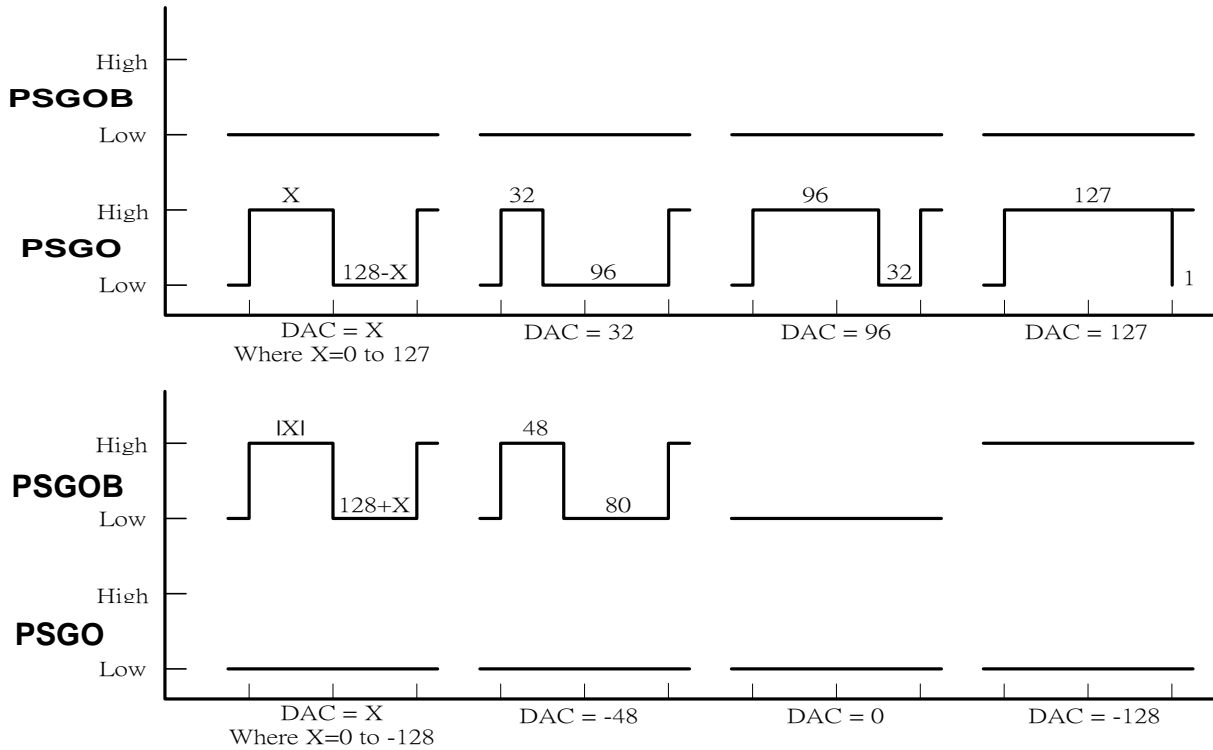

FIGURE 14-7 Two-Pin Push Pull Mode Wave Form

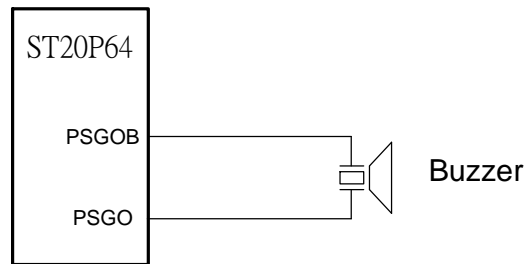

FIGURE 14-8 Two-Pin Push Pull Mode Application Circuit

15. LCD

ST20P64 is capable of driving one 1/16 duty, 1/5 bias LCD panel of segment number from 32 to 48 (up to 768 dots). LCD block includes display frame buffer (\$1000~ \$10AF) for storing display data, 16 common and 32 segment dedicated drives. The rest 16 segment drives are shared with two I/O ports, Port-B/C. Data in frame buffer is undefined after power on, so correct frame data should be filled in before turn on display. One double DC-DC converter is equipped for higher LCD voltage, and is

controlled by LPWR (LCTL[7]) for on/off. The LCD power should be turned on before setting display on, and should be turned off after setting display off. Both SYSCK and OSCX can be chose as LCD clock source, therefore the display can still works after power down. There are two frame rate options, 64Hz and 85Hz, for each different clock sources. In case of 64Hz frame rate, 8-level driving strength and 12-level contrast are adjustable by software for different panel size and LC voltage.

15.1 LCD Waveform

LCD driving waveform is based on the display data and the alternation signal, which toggles every one frame. The

related output voltage levels are shown below. Figure 14-1 shows the common and segment waveforms for one frame.

TABLE 15-1 Driver Output Levels

Driver	Mode	Alternation	Display data output level
Common	Selected	H	VP
		L	V5 (GND)
	Non-selected	H	V1
		L	V4
Segment	Selected	H	VP
		L	V5 (GND)
	Non-selected	H	V2
		L	V3

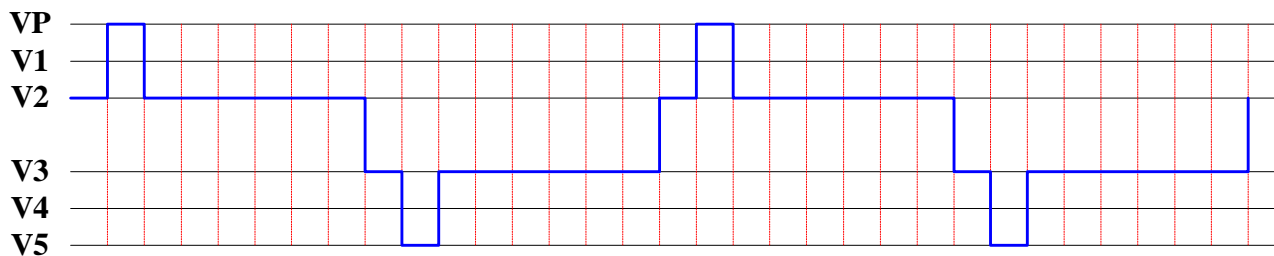

FIGURE 15-1 LCD Segment Waveform

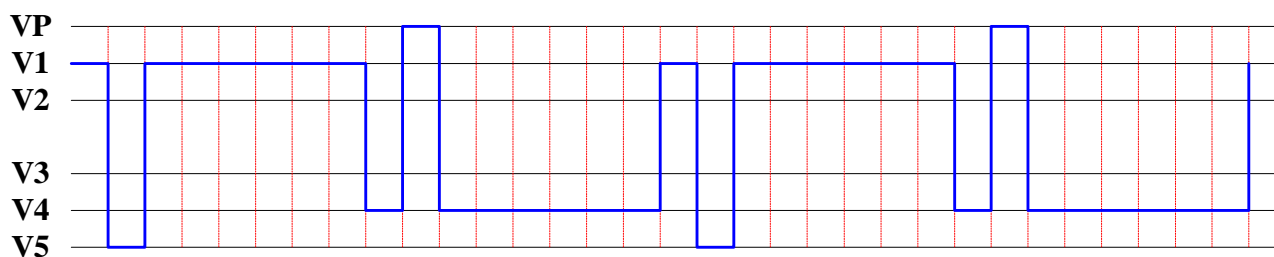

FIGURE 15-2 LCD Common Waveform

15.2 LCD Control Register

TABLE 15-2 LCD Segment Number Selection Register (LSEL)

Address	Name	R/W	Bit 7	Bit 6	Bit 5	Bit 4	Bit 3	Bit 2	Bit 1	Bit 0	Default					
\$039	LSEL	R/W	DUTY[1]	DUTY[0]	BIAS4	LSEL[4]	LSEL[3]	LSEL[2]	LSEL[1]	LSEL[0]	0001 1111					
<p>Bit 7-6: DUTY[1:0] : LCD duty selection 0X = 1/16 duty 10 = 1/12 duty 11 = 1/8 duty</p> <p>Bit 5: BIAS4 : LCD bias selection 1 = 1/4 bias 0 = 1/5 bias</p> <p>Bit 4-0: LSEL[4:0] : LCD segment number selection</p>																
Pad Definition																
LSEL[4:0]	PAD 27	PAD 28	PAD 29	PAD 30	PAD 31	PAD 32	PAD 33	PAD 34	PAD 35	PAD 36	PAD 37	PAD 38	PAD 39	PAD 40	PAD 41	PAD 42
0 xxxx	PC0	PC1	PC2	PC3	PC4	PC5	PC6	PC7	PB0	PB1	PB2	PB3	PB4	PB5	PB6	PB7
1 0000	SEG32	PC1	PC2	PC3	PC4	PC5	PC6	PC7	PB0	PB1	PB2	PB3	PB4	PB5	PB6	PB7
1 0001	SEG32	SEG33	PC2	PC3	PC4	PC5	PC6	PC7	PB0	PB1	PB2	PB3	PB4	PB5	PB6	PB7
1 0010	SEG32	SEG33	SEG34	PC3	PC4	PC5	PC6	PC7	PB0	PB1	PB2	PB3	PB4	PB5	PB6	PB7
1 0011	SEG32	SEG33	SEG34	SEG35	PC4	PC5	PC6	PC7	PB0	PB1	PB2	PB3	PB4	PB5	PB6	PB7
1 0100	SEG32	SEG33	SEG34	SEG35	SEG36	PC5	PC6	PC7	PB0	PB1	PB2	PB3	PB4	PB5	PB6	PB7
1 0101	SEG32	SEG33	SEG34	SEG35	SEG36	SEG37	PC6	PC7	PB0	PB1	PB2	PB3	PB4	PB5	PB6	PB7
1 0110	SEG32	SEG33	SEG34	SEG35	SEG36	SEG37	SEG38	PC7	PB0	PB1	PB2	PB3	PB4	PB5	PB6	PB7
1 0111	SEG32	SEG33	SEG34	SEG35	SEG36	SEG37	SEG38	SEG39	PB0	PB1	PB2	PB3	PB4	PB5	PB6	PB7
1 1000	SEG32	SEG33	SEG34	SEG35	SEG36	SEG37	SEG38	SEG39	SEG40	PB1	PB2	PB3	PB4	PB5	PB6	PB7
1 1001	SEG32	SEG33	SEG34	SEG35	SEG36	SEG37	SEG38	SEG39	SEG40	SEG41	PB2	PB3	PB4	PB5	PB6	PB7
1 1010	SEG32	SEG33	SEG34	SEG35	SEG36	SEG37	SEG38	SEG39	SEG40	SEG41	SEG42	PB3	PB4	PB5	PB6	PB7
1 1011	SEG32	SEG33	SEG34	SEG35	SEG36	SEG37	SEG38	SEG39	SEG40	SEG41	SEG42	SEG43	PB4	PB5	PB6	PB7
1 1100	SEG32	SEG33	SEG34	SEG35	SEG36	SEG37	SEG38	SEG39	SEG40	SEG41	SEG42	SEG43	SEG44	PB5	PB6	PB7
1 1101	SEG32	SEG33	SEG34	SEG35	SEG36	SEG37	SEG38	SEG39	SEG40	SEG41	SEG42	SEG43	SEG45	SEG45	PB6	PB7
1 1110	SEG32	SEG33	SEG34	SEG35	SEG36	SEG37	SEG38	SEG39	SEG40	SEG41	SEG42	SEG43	SEG45	SEG45	SEG46	PB7
1 1111	SEG32	SEG33	SEG34	SEG35	SEG36	SEG37	SEG38	SEG39	SEG40	SEG41	SEG42	SEG43	SEG45	SEG45	SEG46	SEG47

TABLE 15-3 LCD Control Register (LCTL)

Address	Name	R/W	Bit 7	Bit 6	Bit 5	Bit 4	Bit 3	Bit 2	Bit 1	Bit 0	Default
\$03A	LCTL	R/W	LPWR	BLANK	REV	SCAN	CTR[3]	CTR[2]	CTR[1]	CTR[0]	1000 0000

- Bit 7: **LPWR** : LCD power ON/OFF bit
 1 = LCD power OFF
 0 = LCD power ON
- Bit 6: **BLANK** : LCD display ON/OFF bit
 1 = Disable LCD display (Common line is still scanning)
 0 = Enable LCD display
- Bit 5: **REV** : LCD display reverse
 1 = Reverse display
 0 = Normal display
- Bit 4: **SCAN** : LCD segment keyboard scan function
 1 = Enable LCD keyboard awaking pulse in LCD waveforms
 0 = Disable LCD keyboard awaking pulse
- Bit 3~0: **CTR[3~0]** : LCD contrast control

1/16duty & 1/8duty

Frame Rate = 64Hz		Frame Rate = 85Hz	
00xx = contrast level	12	0xxx = contrast level	8
0100 = contrast level	12 (maximum)	1000 = contrast level	8 (maximum)
0101 = contrast level	11	1001 = contrast level	7
0110 = contrast level	10	1010 = contrast level	6
0111 = contrast level	9	1011 = contrast level	5
1000 = contrast level	8	1100 = contrast level	4
1001 = contrast level	7	1101 = contrast level	3
1010 = contrast level	6	1110 = contrast level	2
1011 = contrast level	5	1111 = contrast level	1 (minimum)
1100 = contrast level	4		
1101 = contrast level	3		
1110 = contrast level	2		
1111 = contrast level	1 (minimum)		

1/12duty

Frame Rate = 64Hz		Frame Rate = 85Hz	
0000 = contrast level	16 (maximum)	00xx = contrast level	10
0001 = contrast level	15	0100 = contrast level	10
0010 = contrast level	14	0101 = contrast level	10
0011 = contrast level	13	0110 = contrast level	10 (maximum)
0100 = contrast level	12	0111 = contrast level	9
0101 = contrast level	11	1000 = contrast level	8
0110 = contrast level	10	1001 = contrast level	7
0111 = contrast level	9	1010 = contrast level	6
1000 = contrast level	8	1011 = contrast level	5
1001 = contrast level	7	1100 = contrast level	4
1010 = contrast level	6	1101 = contrast level	3
1011 = contrast level	5	1110 = contrast level	2
1100 = contrast level	4	1111 = contrast level	1 (minimum)
1101 = contrast level	3		
1110 = contrast level	2		
1111 = contrast level	1 (minimum)		

TABLE 15-4 LCD Clock Source and Driving Strength Control Register

Address	Name	R/W	Bit 7	Bit 6	Bit 5	Bit 4	Bit 3	Bit 2	Bit 1	Bit 0	Default
\$03B	LCK	R/W	DRV[3]	DRV[2]	DRV[1]	DRV[0]	PUMPB	LCK[2]	LCK[1]	LCK[0]	1111 0000

Bit 7~3: DRV[3:0] : LCD driving strength control

LCK[7:4]	Driving strength Frame rate=64Hz	1/16 Duty consumption (uA)	1/12 Duty consumption (uA)	1/8 Duty consumption (uA)
0000	Level 16	145.76	144.76	48.76
0001	Level 15	137.76	144.76	45.76
0010	Level 14	129.76	144.76	43.76
0011	Level 13	121.76	144.76	40.76
0100	Level 12	112.76	144.76	37.76
0101	Level 11	104.76	144.76	35.76
0110	Level 10	96.76	132.76	32.76
0111	Level 9	88.76	120.76	29.76
1000	Level 8	79.76	109.76	27.76
1001	Level 7	71.76	97.76	24.76
1010	Level 6	63.76	85.76	21.76
1011	Level 5	55.76	73.76	19.76
1100	Level 4	46.76	61.76	16.76
1101	Level 3	38.76	49.76	13.76
1110	Level 2	29.76	37.76	11.76
1111	Level 1(mini.)	21.76	25.76	7.76

1/16duty & 1/8duty

Frame Rate = 64Hz		Frame Rate = 85Hz	
0000	= driving level 16 (maximum)	00XX	= driving level 12
0001	= driving level 15	0100	= driving level 12 (maximum)
0010	= driving level 14	0101	= driving level 11
	⋮		⋮
	⋮		⋮
1101	= driving level 3	1101	= driving level 3
1110	= driving level 2	1110	= driving level 2
1111	= driving level 1 (minimum)	1111	= driving level 1 (minimum)

1/12duty

Frame Rate = 64Hz		Frame Rate = 85Hz	
00XX	= driving level 11	0XXX	= driving level 8
0100	= driving level 11	1000	= driving level 8 (maximum)
0101	= driving level 11 (maximum)	1001	= driving level 7
0110	= driving level 10		⋮
	⋮		⋮
	⋮		⋮
1101	= driving level 3	1101	= driving level 3
1110	= driving level 2	1110	= driving level 2
1111	= driving level 1 (minimum)	1111	= driving level 1 (minimum)

Bit 3: **PUMPB** :

- 1 = Without DC-DC voltage converter for LCD driver
- 0 = With DC-DC voltage converter for LCD driver

Bit 2~0: **LCK[2:0]** : LCD frame rate control

LCK[2:0]	Clock Source	Frame Rate
000	OSCX (32768Hz)	64 Hz
001	OSCX (32768Hz)	85 Hz
010	OSC (2MHz)	64 Hz
011	OSC (2MHz)	85 Hz
100	OSC (4MHz)	64 Hz
101	OSC (4MHz)	85 Hz
110	OSC (8MHz)	64 Hz
111	OSC (8MHz)	85 Hz

15.3 Keyboard-scan Function on LCD drives

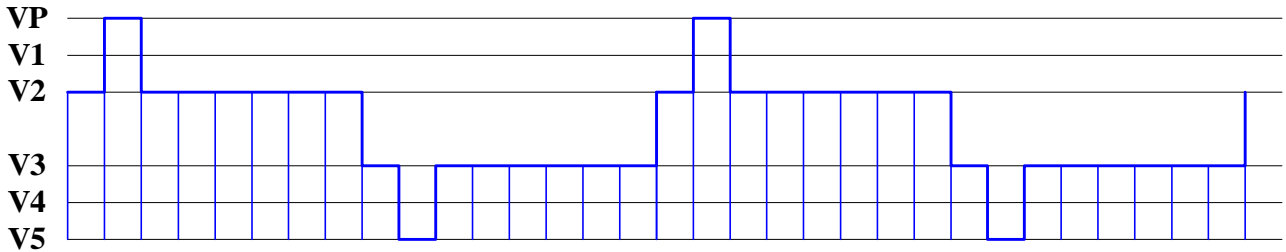

FIGURE 15-3 LCD Segment Waveform (With Keyboard Awaking Pulses)

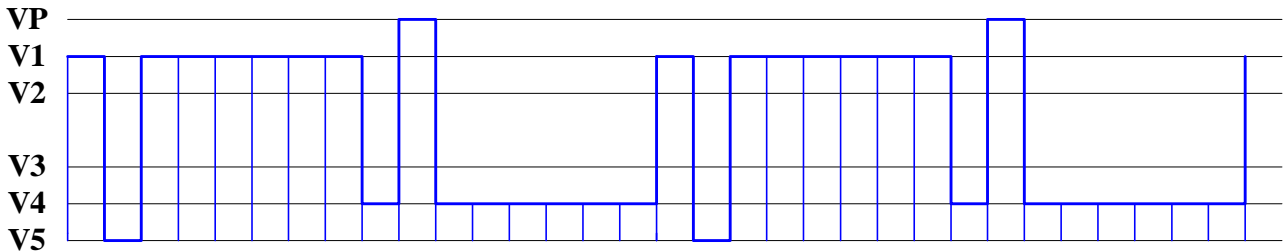

FIGURE 15-4 LCD Common Waveform (With Keyboard Awaking Pulses)

15.3.2 Keyboard-scan Function Example:

- a. Keyboard : 64Keys (8x8)
- b. Return Lines : Port-A
- c. Scan Lines : Port-B

INITIAL_Port_And_LCD

```

SMB4 <LCTL           ;;Enable Keyboard Awaking Pulses Waveform
LDA #00011111B       ;;Set all shared pins to be segments
STA <LSEL

STZ <PCA             ;;Set Port-A as Inputs for Return Line
LDA #FFH
STA <PA              ;;Port-A Pull-High
STA <PCB             ;;Set Port-B as Outputs for Scan Line
LDA #11000000B
STA <PMCR           ;;Enable Pull up & Debounce
LDA #00010000B
STA <IENA           ;;Enable Port-A Interrupt
LDA <PA             ;;Keep Port-A last state
LDA #$FF
STA <PAK            ;;Port-A used as keyboard return line
STZ <IREQ           ;;Reset Interrupt Request Register

CLI
    
```

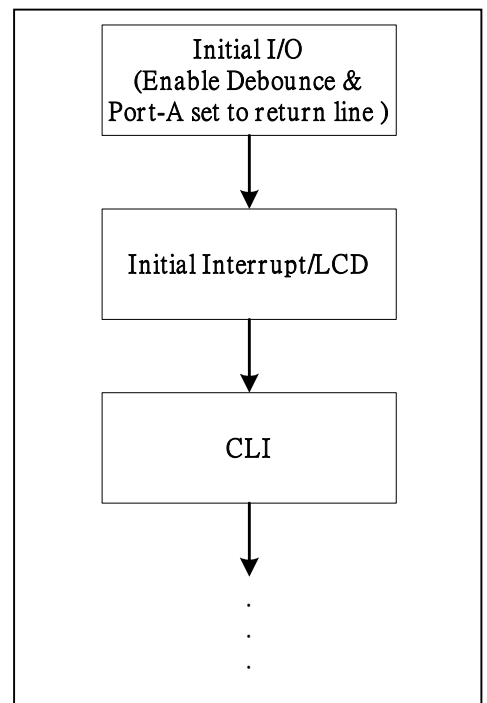

Interrupt-Subroutine

```

Port_ISR
PHA
PHX

LDA #1111110B ;;Initial scanning value for Port-B
STA <ScanValue

?Scan_PB
STA <PB
STZ <PAK ;; Port-A used as normal I/O
RMB3 <LSEL ;;Change segments to be Port-B
LDX #$FF
:
wait 12us ; ;Wait for return line to be stable
:
RMB4 <LCTL ;If keyboard awaking pulses and hardware
LDA <PA ;debounce are enabled together, keyboard awaking
SMB4 <LCTL ;pulses must be disabled before latch Port-A.

SMB3 <LSEL ;;Change Port-B to be segments
STX <PAK ;;Port-A used as keyboard return line
JSR Store-Key-Data ;;This subroutine should be defined by user
ROL <Scanvalue ;;Shift scanning value left
LDA <Scanvalue
BCS ?Scan_PB
.
PLX
PLA
RTI
    
```

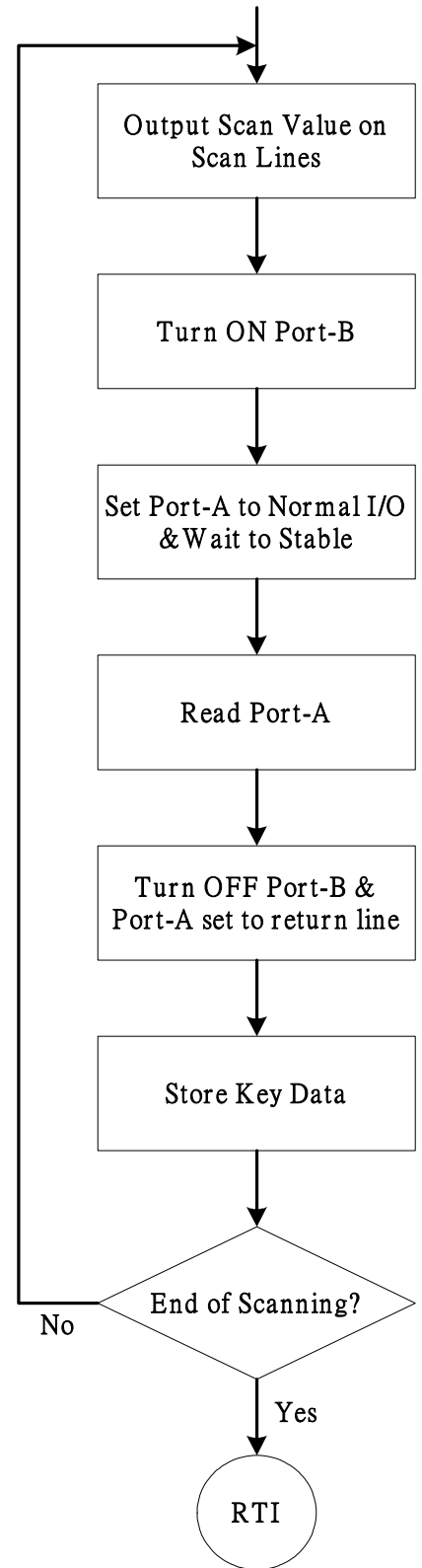

15.4 LCD Frame Buffer

Each pixel of LCD panel is directly mapped into LCD frame buffer. If some segments are not used, the corresponding

RAM can still be accessed for data memory. Refer to TABLE 15-5 for detail mapping.

TABLE 15-5 LCD Frame Buffer Memory Mapping

	SEG0	SEG1	SEG2	SEG3	SEG4	SEG5		SEG47
Address	1000H	1001H	1002H	1003H	1004H	1005H		102FH
COM0	Bit7	Bit7	Bit7	Bit7	Bit7	Bit7	Bit7
COM1	Bit6	Bit6	Bit6	Bit6	Bit6	Bit6		Bit6
COM2	Bit5	Bit5	Bit5	Bit5	Bit5	Bit5	Bit5
COM3	Bit4	Bit4	Bit4	Bit4	Bit4	Bit4		Bit4
COM4	Bit3	Bit3	Bit3	Bit3	Bit3	Bit3	Bit3
COM5	Bit2	Bit2	Bit2	Bit2	Bit2	Bit2		Bit2
COM6	Bit1	Bit1	Bit1	Bit1	Bit1	Bit1	Bit1
COM7	Bit0	Bit0	Bit0	Bit0	Bit0	Bit0		Bit0
Address	1080H	1081H	1082H	1083H	1084H	1085H		10AFH
COM8	Bit7	Bit7	Bit7	Bit7	Bit7	Bit7	Bit7
COM9	Bit6	Bit6	Bit6	Bit6	Bit6	Bit6		Bit6
COM10	Bit5	Bit5	Bit5	Bit5	Bit5	Bit5	Bit5
COM11	Bit4	Bit4	Bit4	Bit4	Bit4	Bit4		Bit4
COM12	Bit3	Bit3	Bit3	Bit3	Bit3	Bit3	Bit3
COM13	Bit2	Bit2	Bit2	Bit2	Bit2	Bit2		Bit2
COM14	Bit1	Bit1	Bit1	Bit1	Bit1	Bit1	Bit1
COM15	Bit0	Bit0	Bit0	Bit0	Bit0	Bit0		Bit0

Note: Undefined RAM area, \$1030~\$107F and \$10B0~\$10FF, is not accessible.

16. POWER DOWN MODES

ST20P64 has three power down modes: WAI-0, WAI-1 and STP. The instruction WAI will enable either WAI-0 or WAI-1, which is controlled by **WAIT**(SYS[2]). And the instruction

STP will enable **STP** mode in the same manner. WAI-0 and WAI-1 modes can be waked up by interrupt. However, **STP** mode can only be waked up by hardware reset.

TABLE 16-1 System Control Register (SYS)

Address	Name	R/W	Bit 7	Bit 6	Bit 5	Bit 4	Bit 3	Bit 2	Bit 1	Bit 0	Default
\$030	SYS	R/W	XSEL	OSTP	XSTP	TEST	WSKP	WAIT	-	LVDET	0000 00-0
<p>Bit 3: WSKP : System warm-up control bit 1 = Warm-up to 16 oscillation cycles 0 = Warm-up to 256 oscillation cycles</p> <p>Bit 2: WAIT : WAI-0 / WAI-1mode select bit 1 = WAI instruction causes the chip to enter WAI-1 mode 0 = WAI instruction causes the chip to enter WAI-0 mode</p>											

16.1 WAI-0 Mode:

If **WAIT** is cleared, WAI instruction makes MCU enter WAI-0 mode. In the mean time, the oscillator, interrupts, timer/counter, and PSG are still working. On the other hand CPU and the related instruction execution stop. All registers, RAM, and I/O pins will retain the same states as those before the MCU entered power down mode. WAI-0 mode

can be waked up by reset or interrupt request even If user sets interrupt disable flag I. In that case MCU will be waked up but not entering interrupt service routine. If interrupt disable flag is cleared (I=0'), the corresponding interrupt vector will be fetched and the service routine will be executed. The sample program is shown below:

```
LDA    #$00
STA    <SYS
WAI                    ; WAI 0 mode
```

16.2 WAI-1 Mode:

If **WAIT** is set, WAI instruction makes MCU enter WAI-1 mode. In this mode, CPU stops, but the PSG, timer/counter keep running if their clock sources are from OSCX. The

wake-up procedure is the same as for WAI-0. The difference is that the warm-up cycles occurs when waking from WAI-1. Sample program is shown as following:

```
LDA    #$04
STA    <SYS
WAI                    ; WAI 1 mode
```

16.3 STP Mode:

STP instruction will force MCU to enter stop mode. In this mode, MCU stops, but PSG, timer/counter won't stop if the clock source is from OSCX. In power-down mode, MCU

can only be waked up by hardware reset, and the warm-up cycles occurs at the same time.

FIGURE 16-1 Status Under Power Down Modes

SYSCK source is OSC:

Mode	Timer0,1	SYSCK	OSC	OSCX	Base Timer	RAM	REG.	LCD	I/O	Wake-up condition
WAI-0	Retain									Reset, Any interrupt
WAI-1	Stop	Stop	Stop	Retain					Reset, Any interrupt	
STP	Stop	Stop	Stop	Retain					Reset	

SYSCK source is OSCX:

Mode	Timer0,1	SYSCK	OSC	OSCX	Base Timer	RAM	REG.	LCD	I/O	Wake-up condition
WAI-0	Retain									Reset, Any interrupt
WAI-1	Stop	Stop	Retain							Reset, Any interrupt
STP	Stop	Stop	Retain							Reset

17. LOW VOLTAGE DETECTOR

ST20P64 has a built-in low voltage detector for power management. When **LVDET** is set, detector circuit is enabled and the detection result will be outputted at the same bit after 3 μ s. Using read instruction twice can get this result: first read will enable initial stableness control.

Second read equal '1' represents 'low voltage'. Once low voltage detector is enabled, it keeps on consuming power. So it is important that remember to write "0" to LVDET to disable the detector after detection is completed. One sample program is shown below:

Start:

```
SMB0 <SYS ; enable detector
:
Wait 3  $\mu$ s
:
CLC
BBR0 <SYS,$+3
BBR0 <SYS,Normal_Voltage
```

Low_Voltage:

```
SEC
```

Normal_Voltage:

```
RMB0 <SYS ; disable detector
```

TABLE 17-1 System Control Register (SYS)

Address	Name	R/W	Bit 7	Bit 6	Bit 5	Bit 4	Bit 3	Bit 2	Bit 1	Bit 0	Default
\$030	SYS	R/W	XSEL	OSTP	XSTP	TEST	WSKP	WAIT	-	LVDET	0000 00-0
Bit 0: LVDET : Low voltage detect 1 = Enable detector (write) / Low voltage (read) 0 = Disable detector (write) / Normal voltage (read)											

18. ELECTRICAL CHARACTERISTICS

DC Supply Voltage ----- -0.3V to +4.5V
 Operating Ambient Temperature ----- -10°C to +60°C
 Storage Temperature ----- -10°C to +125°C

***Notice:** Stresses above those listed under "Absolute Maximum Ratings" may cause permanent damage to the device. All the ranges are stress ratings only. Functional operation of this device at these or any other conditions above those indicated in the operational sections of this specification is not implied or intended. Exposed to the absolute maximum rating conditions for extended periods may affect device reliability.

18.1 DC Electrical Characteristics

Standard operation conditions: VCC = 3.0V, GND = 0V, TA = 25°C, OSC = 2M Hz, unless otherwise specified

Parameter	Symbol	Min.	Typ.	Max.	Unit	Condition
Operating Voltage	VCC	2.6	3	3.6	V	Logic
				5.5		Built-in double DC-DC voltage converter for LCD driver:
Operating Current	I _{OP}		1000	1500	μA	All I/O ports are input and pull-up, LCD driving strength is maximum.
Standby Current	I _{SB0}		2	3	μA	All I/O ports are input and pull-up, OSCX on, LCD off (WAIT1/STOP mode)
Standby Current	I _{SB1}		85	130	μA	All I/O ports are input and pull-up, OSCX on, LCD off (WAIT0 mode)
LCD consumption	I _{LCD}		23		μA	LCD Clock source=OSCX Driving strength=1/16 Condition: WAIT1 mode. 1/16duty
LCD consumption	I _{LCD}		145		μA	LCD Clock source=OSCX Driving strength=16/16 Condition: WAIT1 mode. 1/16duty
Input High Voltage	V _{IH}	0.7V _{CC} 0.85V _{CC}		V _{CC} +0.3	V	PORT A, PORT B, PORT C
					V	Reset, INX
Input Low Voltage	V _{IL}	GND-0.3		0.3V _{CC} 0.15V _{CC}	V	PORT A, PORT B, PORT C
					V	Reset, INX
Pull-up resistance	R _{IH}		130		KΩ	PORTA (Voltage difference=VDD-0.7VDD)
Pull-up resistance	R _{IH}		140		KΩ	PORTB, PORT C (Voltage difference==VDD-0.7VDD)
Output high voltage	V _{OH1}	0.7V _{CC}			V	PORTA (IOH=-3.5mA)
Output high voltage	V _{OH1}	0.7V _{CC}			V	PORTB, PORTC (IOH=-3.5mA)
Output low voltage	V _{OL1}			0.3V _{CC}	V	PORTA (IOL=7.5mA)
Output low voltage	V _{OL1}			0.3V _{CC}	V	PORTB, PORT C (IOL=7mA)
Output high voltage	V _{OH2}	0.7V _{CC}			V	PSG/DAC, IOH = -25mA.
Output low voltage	V _{OL2}			0.3V _{CC}	V	PSG/DAC, IOL= 53mA.
OSCX start time	T _{STT}		1	2	s	
Low voltage detector	V _{LVD}	2.4		2.7	V	
Low voltage detector current	I _{lvdet}		110		uA	No detector voltage adjustment

FIGURE 18-1 Relation between operation voltage & frequency

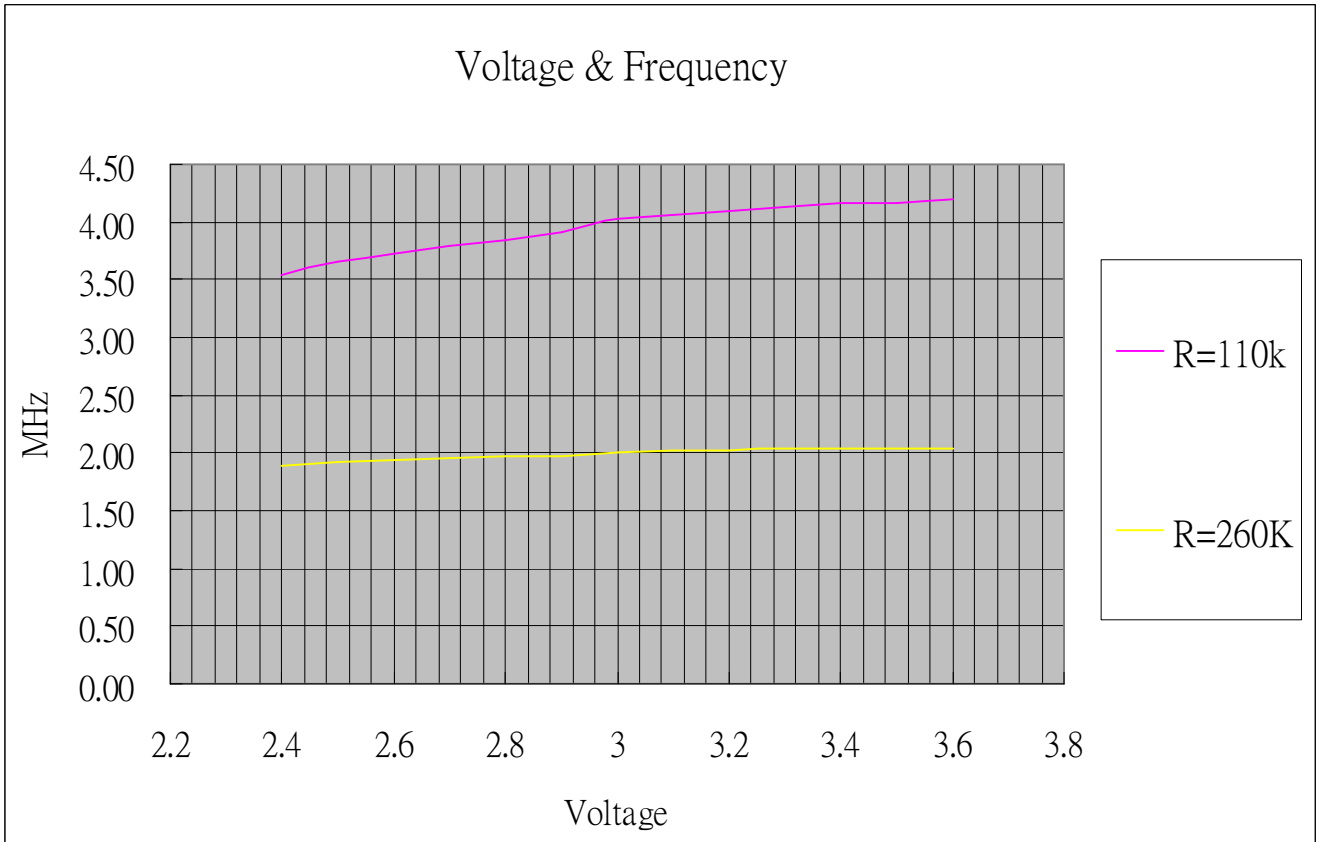

TABLE 18-1 R-Oscillator V.S. Frequency

Voltage \ Freq.	3V	5V
	4MHz	110Kohm
2MHz	260Kohm	274Kohm
1MHz	570Kohm	590Kohm
500KHz	1240Kohm	1220Kohm

19. APPLICATION CIRCUIT

19.1 APPLICATION CIRCUIT UNDER 3V OPERATING VOLTAGE

VDD : 3V
 Clock : 32768Hz crystal and 2.0MHz RC oscillator
 LCD : 1/16 duty
 I/O : PORT A
 ALARM : PSGO, PSGOB

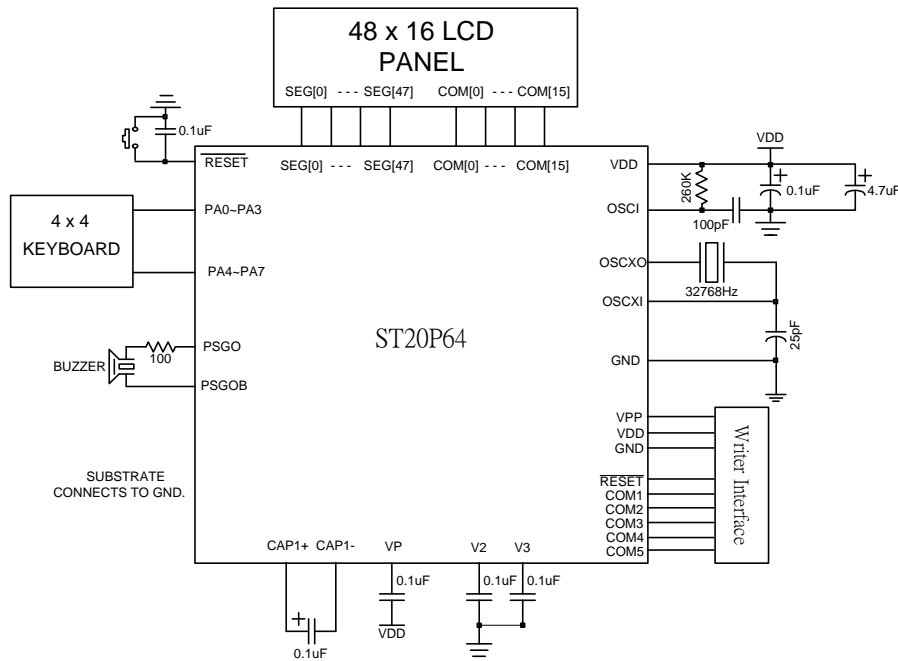

FIGURE 19-1 APPLICATION CIRCUIT WITHOUT LCD KEYBOARD AWAKING PULSE

VDD : 3V
 Clock : 32768Hz crystal and 2.0MHz RC oscillator
 LCD : 1/16 duty
 I/O : PORT A
 ALARM : PSGO, PSGOB

Note:

1. COMs and SEGs output GND level, while the LCD is turned off.
2. If LCD is turned off, Keyboard Awakening Pulses must be turned off at the same time.

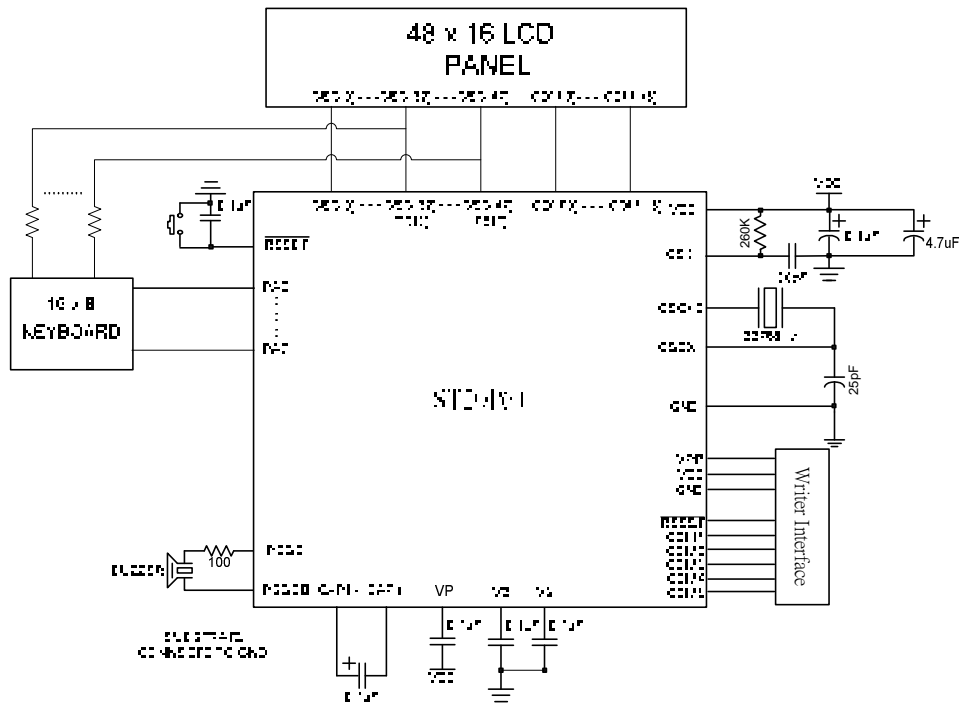

FIGURE 19-2 APPLICATION CIRCUIT WITH LCD KEYBOARD AWAKING PULSE

19.2 APPLICATION CIRCUIT UNDER 5V OPERATING VOLTAGE

VDD	: 5V
Clock	: 32768Hz crystal and 2.0MHz RC oscillator
LCD	: 1/16 duty
I/O	: PORT A/B/C
ALARM	: PSGO, PSGOB

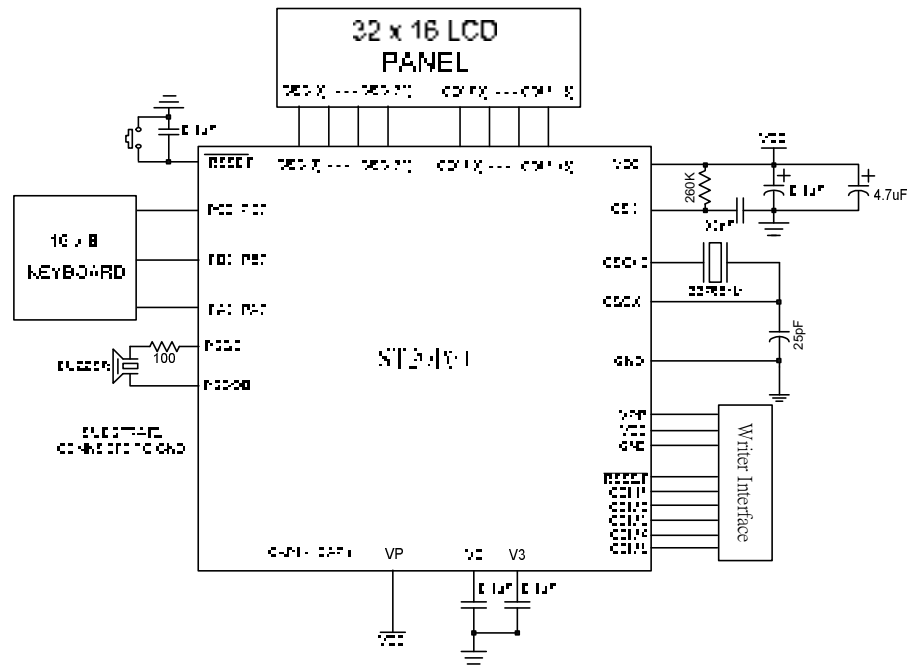

FIGURE 19-3 APPLICATION CIRCUIT WITHOUT DC-DC CONVERTER

ST20P64 EVB PCB113-1

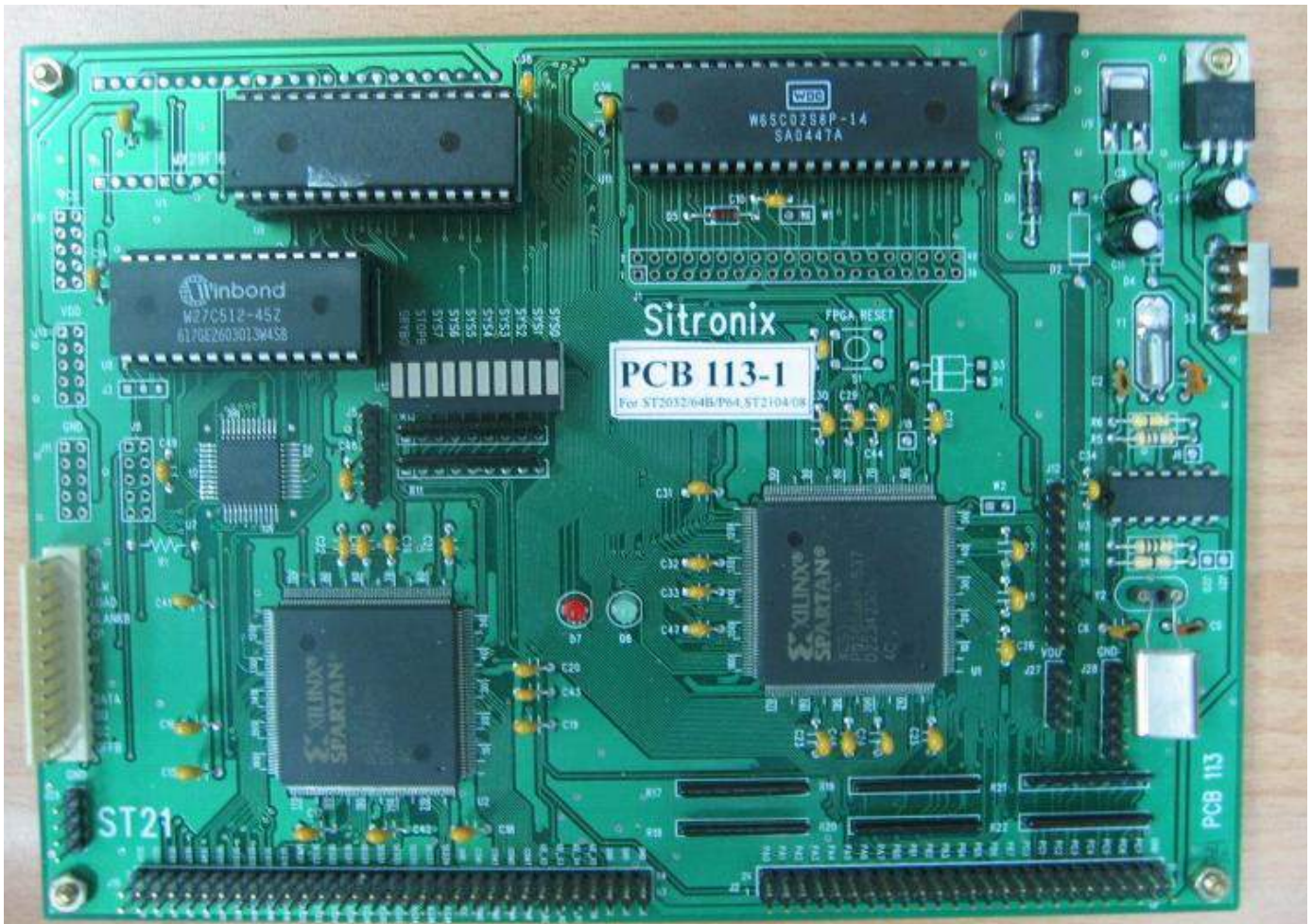

FIGURE 19-4 The PCB 113-1 of ST20P64 EVB

20. OTP ROM PROGRAMMING INTERFACE

20.1 INTERFACE DESCRIPTION

In order to program OTP ROM, several pins have to be reserved on the PCB which is bonding with ST20P64. These

totals are 9 pins that include following list TABLE 20-1. It just be used to connect writer to program OTP ROM.

TABLE 20-1 PIN ASSIGNMENT OF INTERFACE

Pad Name	SPI Interface	Pin Type	Description
VPP	VPP	Power	High Voltage Power Supply 1) OTP Program, Program Verify, Test modes. 12V 2) OTP Read: VDD (<6V) /VSS
VDD	VDD	Power	Low Voltage (2.7V-5.5V) Power Supply.
VSS	VSS	Power	
RESETB	RESETB	Input	1) Clear Option bit : Rising-edge (VSS to VDD) of RESET 2) Set Option bit : H + Falling-edge (VDD to VSS) of RESET
Com1	VDD	Input	Working mode selection
Com2	SCK	Input	SPI signal
Com3	SSB	Input	SPI signal
Com4	MOSI	Input	SPI signal
Com5	MISO	Output	SPI signal

20.2 PROGRAMMING FUNCTION SPECIFICATION

In mask ROM type of ST2064B system has two code options, but in OTP ROM type of ST20P64, we should program option to OTP ROM to configure hardware. The option contain 2-bits

that is BILBO and RC/XTAL to comparable with ST2064B. The option word default value is FFh.

TABLE 20-2 Option word

Bit 7	Bit 6	Bit 5	Bit 4	Bit 3	Bit 2	Bit 1	Bit0
BILBO	-	-	-	-	-	-	RC/XTAL
BILBO	-	0: BILBO encode, 1: not encode					
RC/XTAL	-	0: XTAL mode, 1: RC mode					
P.S. A brief description followed below.							
BILBO: Binary code that programming in OTP ROM will can not be read by OTP writer, if the encode is used. The purpose of this function is to keep secret.							

21. PACKAGE INFORMATION

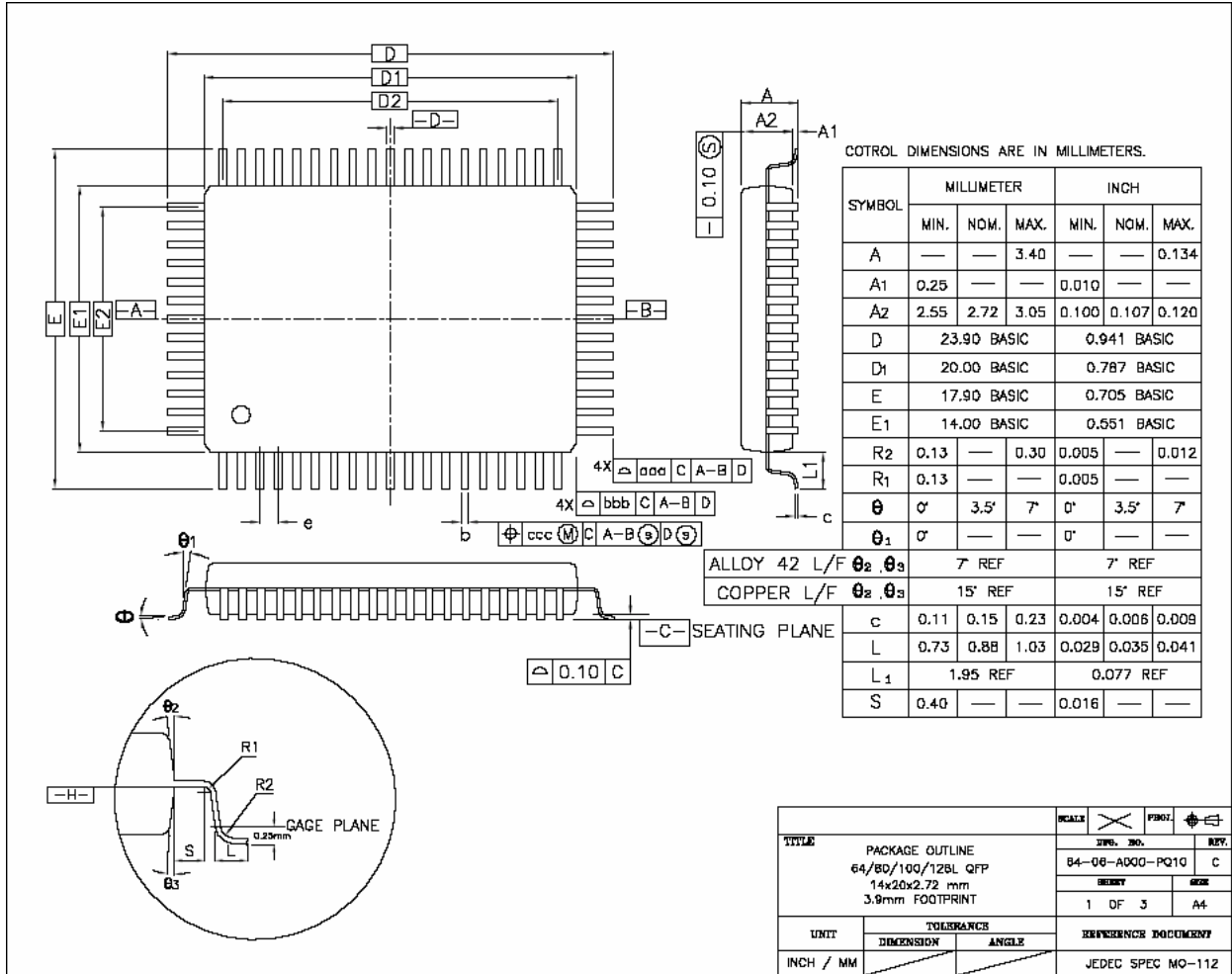

Dimensions in Millimeters

SYMBOL	100L MILLIMETER		
	MIN.	NOM.	MAX.
b	0.22	0.30	0.38
e	0.65 BSC.		
D2	18.85 REF		
E2	12.35 REF		
	TOLERANCE OF FORM AND POSITION		
aaa	0.25		
bbb	0.20		
ccc	0.12		

22. PIN CONFIGURATION (QFP 100)

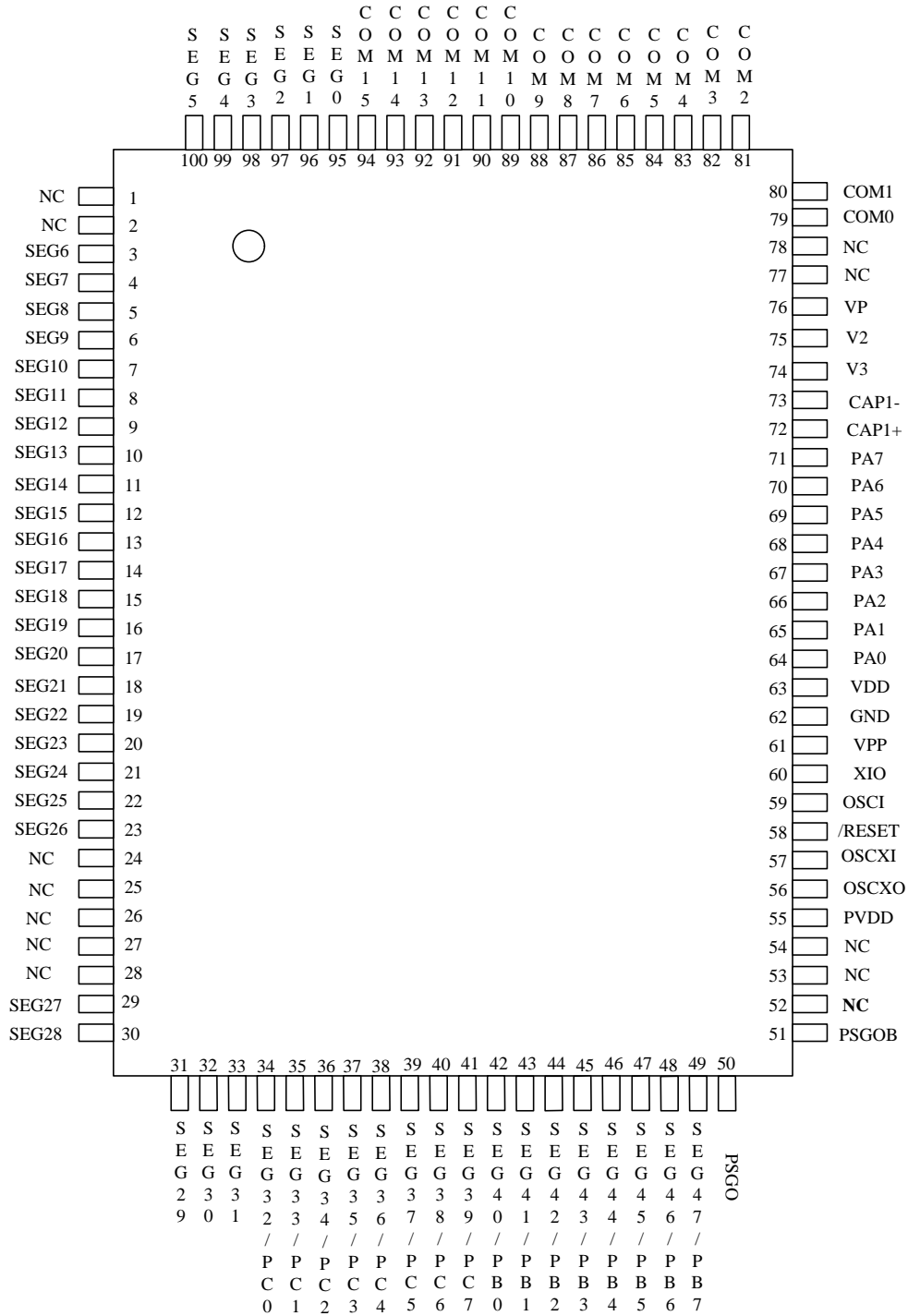

Project name _____ / _____ / _____

	Should be Checked	Check	Note
1	After power on , initial user RAM and confirm control register .		
2	Confirm LCD panel's V_{OP} (contrast level) 、 Duty and Bias .		
3	Confirm the difference between E.V. Board and real chip (ex. V_{OP} 、 driving ability 、 F_{OSC} 、 power consumption 、 noise...etc.)		
4	Before entry power down mode , turn off un-used peripheral. (LCD driver 、 PSG 、 OSC or OSCX)		
5	Make sure power down mode work .		
6	Calculate average operating current . (Wake up time ratio)		
7	Confirm I/O directions and set pull-up for un-used input pins .		
8	For input mode with pull-up function , Please set bit 7 of port condition control register (PMCR[7]) and each bit of port data register .		
9	If use I/O for pin option , please re-configure I/O status after reading . (directions and pull-up resistor)		
10	Pay attention to "bit instructions" , because some registers have different function for read and write acting. ex. PA 、 PB 、 PRS 、 SYS and control register for write only .		
11	Disable un-used function's control register and put "RTI" Instruction at un-used interrupt vector .		
12	Make sure timer counting correct .		
13	Make sure temperature counting correct .		
14	Make sure software key de-bounce work . (10 ~ 50 mS)		
15	Make sure stack memory will not overflow .		
16	Under test mode , every functions / parts must be tested . ex. LCD 、 LED 、 speaker / buzzer 、 key 、 motor and senser...etc.		
17	Please use same parts when developing and producing .		
18	Please select general parts for production.		
19	When testing , write every unusual situation down and find out the reasons indeed.		
20	Make sure the program accept un-normal operatings and system will not hold or crash down .		
21	When you set I/O port as input mode , please make sure signal level stable before reading . ex. When key scan , please delay 12 uS then get key code .		
22	If Port-A want to be read or set to output, Dynamic I/O function must be disabled(PAK[7:0]=0) and wait 12 uS to stable.		
23	LCD frame rate, voltage pump control(LCK[3~0]) & duty / bias selection(LSEL[7~5]) can't be modified while LCD turn on.		
24	Make sure resister of R-OSC on EV-Chip matches desired frequency and equals the crytal on EV-Board.		
25	If LCD clock source is from R-OSC, LCD will have no clock in WAI1 and can't display.		
26	Use LCD-EVchip to check LCD display quality. If there is crosstalk on the first line, please turn on keyboard-scan function for better quality.		
27	Always disable interrupt function(by an " SEI " instruction) when modify the IENAL,IENAH,IREQL and IREQH register		

28	After Power on ,enter wait 0 mode 0.5s before normal operation		
----	--	--	--

Special notice(If the LCD keyboard awaking pulses function was turned on)

1	If two keys be pressed at the same time affect LCD display must be reduced. One resister(47K) should be added between scan line and keyboard, And selecting the LCD driving strength to maximum during the keys were pressed.		
2	When LCD is turned off, please disable Keyboard Awaking Pulses at the same time.		
3	If both the HW debounce and LCD keyboard awaking pulses are enabled, LCD keyboard awaking pulses must be disabled before latch Port-A. rmb4 <LCTL lda <PA smb4 <LCTL		

If this code is modified from ST2064B, please keeping eyes on following list.

1	ST20P64 has Low Voltage Reset function. While the operation voltage is lower than 1.7V, the system will reset automatically.		
2	Operation current is double of ST2064B's.		
3	PA0 input range (VIH & VIL) is different from ST2064B's. (ST20P64: 1.25V,0.89V) (ST2064B: 1.66V,1.44V)		
4	PA0 pull-up resister is smaller than PA1~7, when the system is operating under 5V.		

Engineer _____

Manager _____

Reference table for LCD panel's parameters :

According to your setting of contrast level , mapping to LCD panel's parameter .

[ST2064] – 48 x 16 (frame rate = 64 Hz.)

Contrast		Equivalent Duty	Bias
Level	CTR[3:0]		
<input type="checkbox"/> 1(light)	1111	48.8	5.0
<input type="checkbox"/> 2	1110	41.0	5.0
<input type="checkbox"/> 3	1101	35.3	5.0
<input type="checkbox"/> 4	1100	31.0	5.0
<input type="checkbox"/> 5	1011	27.7	5.0
<input type="checkbox"/> 6	1010	25.0	5.0
<input checked="" type="checkbox"/> 7	1001	22.8	5.0
<input type="checkbox"/> 8	1000	20.9	5.0
<input type="checkbox"/> 9	0111	19.3	5.0
<input type="checkbox"/> 10	0110	18.0	5.0
<input type="checkbox"/> 11	0101	16.8	5.0
<input checked="" type="checkbox"/> 12(dark)	0100	16.0	5.0

[ST2064] – 48 x 16 (frame rate = 85 Hz.)

Contrast		Equivalent Duty	Bias
Level	CTR[3:0]		
<input type="checkbox"/> 1(light)	1111	36.6	5.0
<input type="checkbox"/> 2	1110	30.7	5.0
<input type="checkbox"/> 3	1101	26.5	5.0
<input type="checkbox"/> 4	1100	23.3	5.0
<input checked="" type="checkbox"/> 5	1011	20.8	5.0
<input type="checkbox"/> 6	1010	18.7	5.0
<input type="checkbox"/> 7	1001	17.1	5.0
<input checked="" type="checkbox"/> 8(dark)	1000	16.0	5.0

IC Power On Default.

24. REVISIONS

Version3.0	Page21	Modify PRES 8-bits counter to 16 bit and add description low byte PRS[7~0] : The low byte value of PRES counter	
	Page52	Add ST20P64 EVB photo	
	Page56	Add checklist for customer to confirm ST20P64 EVB PCB number.....	2007/5/21
Version2.9	Page 52	modify Low Voltage Power Supply 2.4V-5.4V to 2.7V~5.5V	2007/4/25
Version2.8	Page 9,13,14,16,17,18	Change register PMCR bit3 PARP to Test bit and must be set "0".....	2006/9/19
Version2.7	Page53,54	move package information to page53.54.....	2006/8/8
Version2.6	Page8,19,20,43,45,	Change register SYS bit4 XBAK to Test bit and must be set "0"	
	Page38,	Modify driving strength level current consumption in heavy mode	
	Page46,	Modify standby and LCD current consumption in heavy mode	
	Page54,	Remove heavy load	
	Page55,	Remove Item 24,28 normal mode in checklist.....	2006/8/1
Version2.5	Page1	RC mode=>add CPU clock 250K ~ 2M Hz High frequency crystal/resonator oscillator mode =>add CPU clock 227.5k~2MHz	2006/06/23
Version2.4	Page56	add checklist item 30=>after Power on, enter wait 0 mode 0.5s before normal operation	2006/5/8
Version2.3	Page20	modify COM8~COM15 output HIGH to FLOATING.....	2006/2/22
Version2.2	Page54~57	add checklist	
	Page48	modify oscillator start time to OSCX heavy start time.....	2006/2/8
Version 2.1	Page 5/6	add QFP outline.....	2005/12/19
Version 2.0	Page 38	add current table	
	Page25/28/30/31	take off PSG/DAC clock source from oscx	
	Page33	modify Two-Pin Two Ended Mode Application Circuit	
	Page11	add pad number and note: all of unused input pins should be pulled up to minimize standby current.....	2005/11/8
Version 1.9	Page45	Modify PSG condition, no share on PB.....	2005/9/26
Version 1.8	Page45	Add LVD range 2.4V~2.7V	2005/08/29
Version 1.7	Page 5	Add PVDD pin no. and pad descriptions	
	Page 25	Make sure PSG function is working normally on the EV or Real Chip Board, Please connect PSG power PVCC to VCC	
	Page36	modify pad definition PC0~PC7, PB0~PB7	
	Page47/48/49	modify figure PSG1/0 to PSGO/PSGOB.....	2005/2/01
Version 1.6	Page 5	Modify pin no. of pad descriptions	2004/12/10
Version 0.5	Page1	modify operation voltage: DC-DC Converter Enable: 2.7V ~ 3.6V DC-DC Converter Disable: 2.7V ~ 5.5V.....	2004/09/21
Version 0.4:	Page 50	Remove Test pin connect writer to program OTP ROM.....	2004/9/01

Version 0.3:

Page40 Modifying processes to latch port-A in interrupt service routing.
Page46 Adding electronically characteristic FIGURE 18-1 & TABLE 18-1.
Page47/48/49 Modifying application circuit.....2004/2/13

Version 0.2:

Page49 Adding OTP ROM programming interface description.....2003/12/3

Version 0.1:

Page 1 Indicating the 64K x 8bit ROM is PROM.
First release.....2003/11/12

ST20P64 is modified from ST2064B

The above information is the exclusive intellectual property of Sitronix Technology Corp. and shall not be disclosed, distributed or reproduced without permission from Sitronix. Sitronix Technology Corp. reserves the right to change this document without prior notice and makes no warranty for any errors which may appear in this document. Sitronix products are not intended for use in life support, critical care, medical, safety equipment, or similar applications where products failure could result in injury, or loss of life, or personal or physical harm, or any military or defense application, or any governmental procurement to which special terms or provisions may apply.