



ST20P08

8K 8-bit Single Chip Microcontroller

Notice: Sitronix Technology Corp. reserves the right to change the contents in this document without prior notice. This is not a final specification. Some parameters are subject to change.

1. FEATURES

- **8-Bit Static Pipeline CPU**
- **ROM: 8K x 8 bits PROM(OTP)**
- **RAM: 192 x 8 bits**
- **32-Level Deep Stack**
- **Operating Voltage : 2.4V ~ 5.5V**
- **Power-on Timer(PWRT)**
 - Pin option to enable
- **General-Purpose I/O (GPIO) Ports**
 - 28 pins are programmable CMOS I/O (Port-A/B/C and Port-E low nibble),20 pins (Port-A high nibble & Port-B/C) are shared with LCD Segments
 - 8 open drain output pins share with LCD COMs
 - Hardware de-bounce option for Port-A
 - Bit programmable pull-up for input pins
- **2 Input Pins**
 - OTP option bit to select (shared with OSCX)
- **30 Output Pins**
 - Eight are shared with LCD com and twenty are shared with LCD Segments, two are shared with PSG
- **Timer / Counter**
 - One 8-bit timer / 16-bit event counter
 - One 8-bit BASE timer
- **Five Powerful Interrupt Sources**
 - External interrupt (edge trigger) / RFC interrupt(Share with external interrupt)
 - TIMER1 interrupt
 - BASE timer interrupt
 - PORTA[7~0] interrupt (transition trigger)
 - DAC reload interrupt
- **Watchdog Timer (WDT)**
 - With its own low power internal oscillator for reliability
 - Four selectable time bases
 - WDT reset CPU only
 - OTP option bit to enable
- One option bit is selectable to reset or not in WAI1 and STP mode
- **Dual Clock Source with Warm-up Timer**
 - OSCX: Low frequency crystal oscillator with 32768Hz
 - OSC: High frequency RC oscillator from 500K ~ 8MHz
CPU clock 250K ~ 4MHz
- **On-chip Internal Oscillator for WDT**
 - < 5uA typical, 3V, 27°C
- **LCD Controller Driver**
 - 16 level contrast control
 - 320 (8x40) dots (1/8 duty, 1/4 bias, programmable)
 - 160 (4x40) dots (1/4 duty, 1/3 bias, programmable)
 - Two clock source options: RC and resonator oscillator
 - Keyboard scan function supported on 40 shared segment drives
 - Internal bias resistors(1/4 bias & 1/3 bias) with 32 level driving strength control
- **Programmable Sound Generator (PSG)**
 - Tone generator
 - Sound effect generator
 - 16 level volume control
 - Digital DAC for speech / tone
- **Resistor Frequency Converter (RFC)**
 - Up to 4 resistors measurement
 - Built-in one independent 16-bits counter without sharing with timer counter
 - 3 clock sources for RFC counter: SYSCK, OSCX and INTX
 - 5 scales of clock divider for RFC counter
- **Carrier Wave Generator(CGR)**
 - Built-in one digital PLL
 - Standard clock rate output for remote control
- **Three Power Down Modes**
 - WAI0 mode
 - WAI1 mode
 - STP mode

2. GENERAL DESCRIPTION

ST20P08 is a low-cost, high-performance, fully static, 8-bit microcontroller designed with CMOS silicon gate technology. It comes with 8-bit pipeline CPU core, SRAM, timer, LCD driver, I/O port, PSG, RFC, CGR, OTP program ROM and built-in dual oscillator. And also, some new functions have been added in the ST20P08 to enhance the performance of ST2016 for more system application.

Power bouncing during power-on is a major problem when designing a reliable system. After the power returns to normal level, the system may recover its original states and keeps working correctly. Furthermore, the Power-on Timer (PWRT) which is designed to provide a fixed delay time, keep the part in reset for longer after power-up or low-V reset released. With these two power management, the system may operate under more stable power supply.

A highly reliable Watchdog Timer(WDT) with its own low power internal oscillator which does not require any external components, provides protection against software lockup. Moreover, the feature of "WDT reset CPU only" make it possible to do the rapid system recovery after Watchdog timer reset. And the option bit is selectable to reset or not in WAI1 and STP mode for various application.

The Resistor Frequency Converter(RFC) which is also a new function added in the ST20P08, can compare three different sensors with the reference resistor separately. With one independent 16-bits counter, the RFC can count and stop automatically only if RFC is enabled. This make it easy for the humidity or thermometric application.

More and more remote control applications are used today. The ST20P08 also equips a Carrier Wave Generator(CGR) to support this application with one digital PLL and provide the standard clock rates output for remote control.

With these integrated functions inside, the ST20P08 single chip microcontroller is a right solution for business equipment and consumer applications. Such as watch, calculator, LCD games, thermometer, hygrometer, IR remote control and so on. ST20P08 is definitely a perfect solution for implementation.

3. BLOCK DIAGRAM

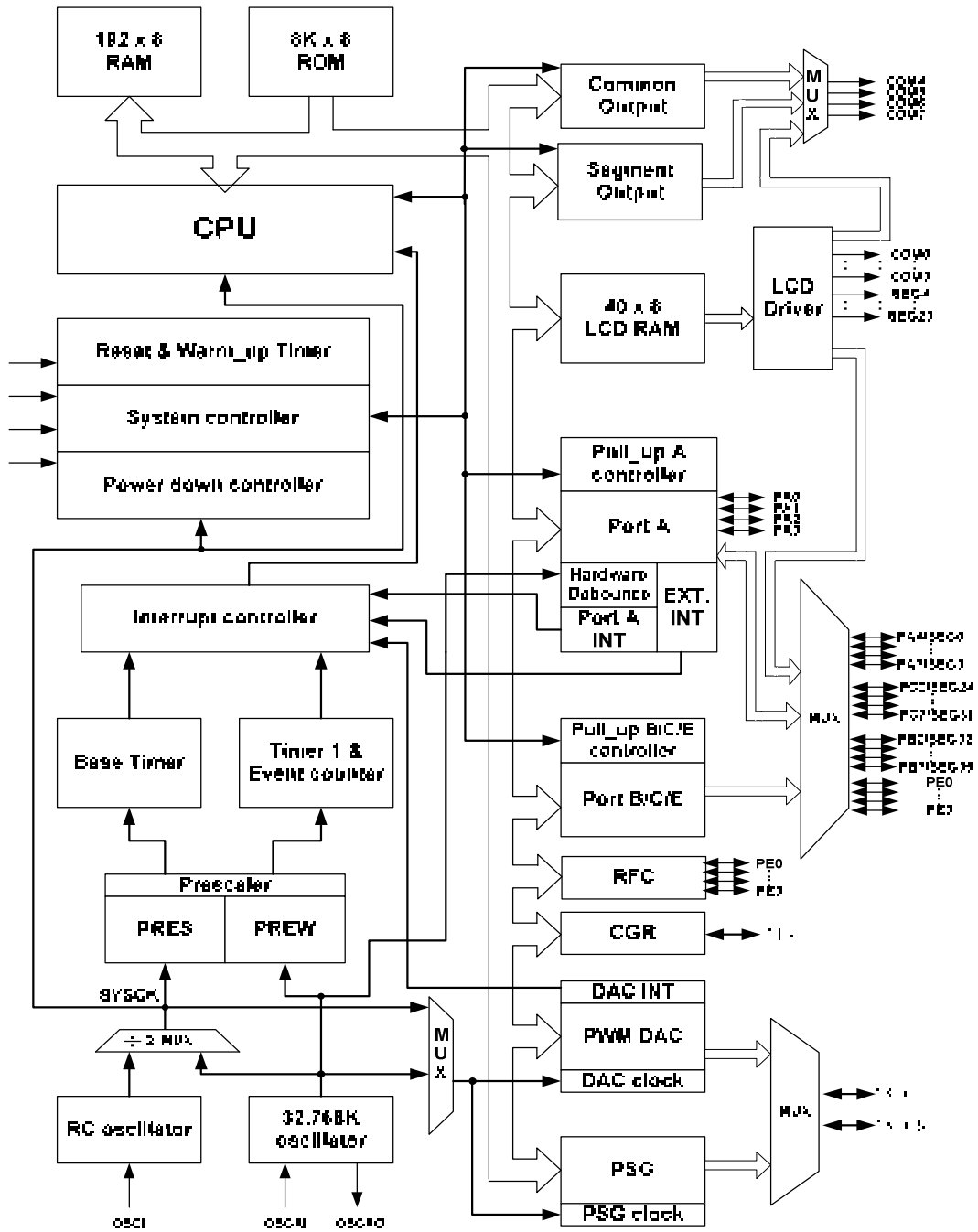

4. PAD DIAGRAM

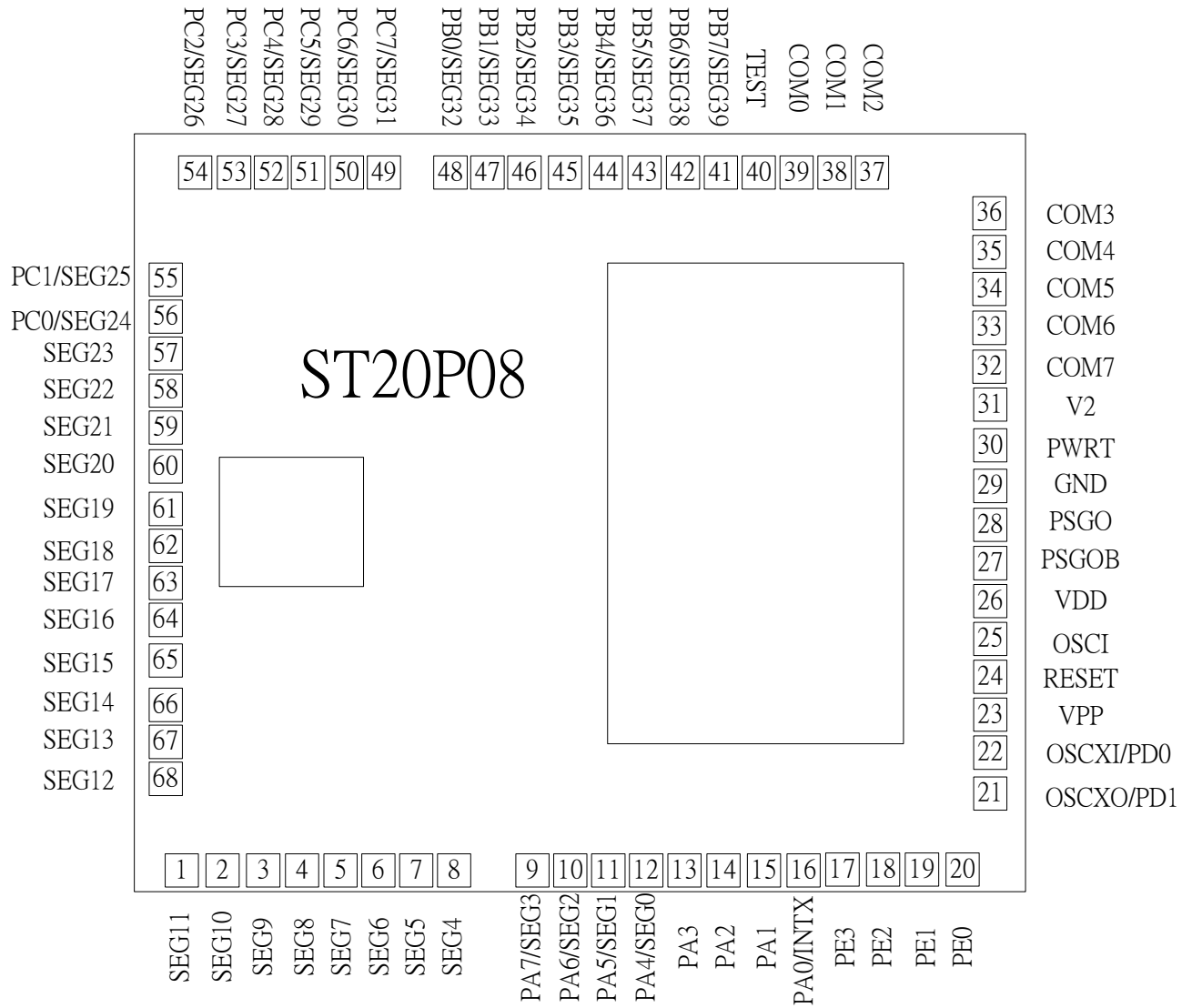

5. PAD DESCRIPTION

Pin No.	Designation	Type	Description
12~9	SEG0/PA4 ~ SEG3/PA7	O I/O	LCD Segment output Port-A bit programmable I/O
8~5	SEG4- SEG7	O	LCD Segment output Segment output port
4~1, 68~65	SEG8 -SEG15	O	LCD Segment output Segment output port
64~57	SEG16-SEG23	O	LCD Segment output Segment output port
56~49	SEG24/PC0 ~ SEG31/PC7	O I/O	LCD Segment output Port-C bit programmable I/O
48~41	SEG32/PB0 ~ SEG39/PB7	O I/O	LCD Segment output Port-B bit programmable I/O
39~32	COM 0 – 7	O O	LCD Common output Open drain output port
24	RESET	I	Pad reset input (HIGH Active)
29	GND	P	Ground Input and chip substrate
16	PA0/INTX	I/O I I I	Port-A bit programmable I/O Edge-trigger Interrupt. Transition-trigger Interrupt Programmable Timer1 clock source
15~9	PA 1-7	I/O I	Port-A bit programmable I/O Transition-trigger Interrupt
28~27	PSGO,PSGOB	O	PSG/DAC Output
26	VDD	P	Power supply
22	OSCXI/PD0	I I	OSC input pin. For 32768Hz crystal Port-D input
21	OSCXO/PD1	O I	OSC output pin. For 32768Hz crystal Port-D input
25	OSCI	I	OSC input pin. Toward to external resistor
20~17	PE0~PE3	I/O	Port-E bit programmable I/O RFC/CGR output
31	V2	O	Multi-level power supply for liquid crystal drive.
23	VPP	P	OTP programming power
40	TEST	I	Chip test function. Leave it open
30	PWRT	I	Power on timer enable control pin.

Legend: I = input, O = output, I/O = input/output, P = power.

6. PACKAGE DIMENSIONS

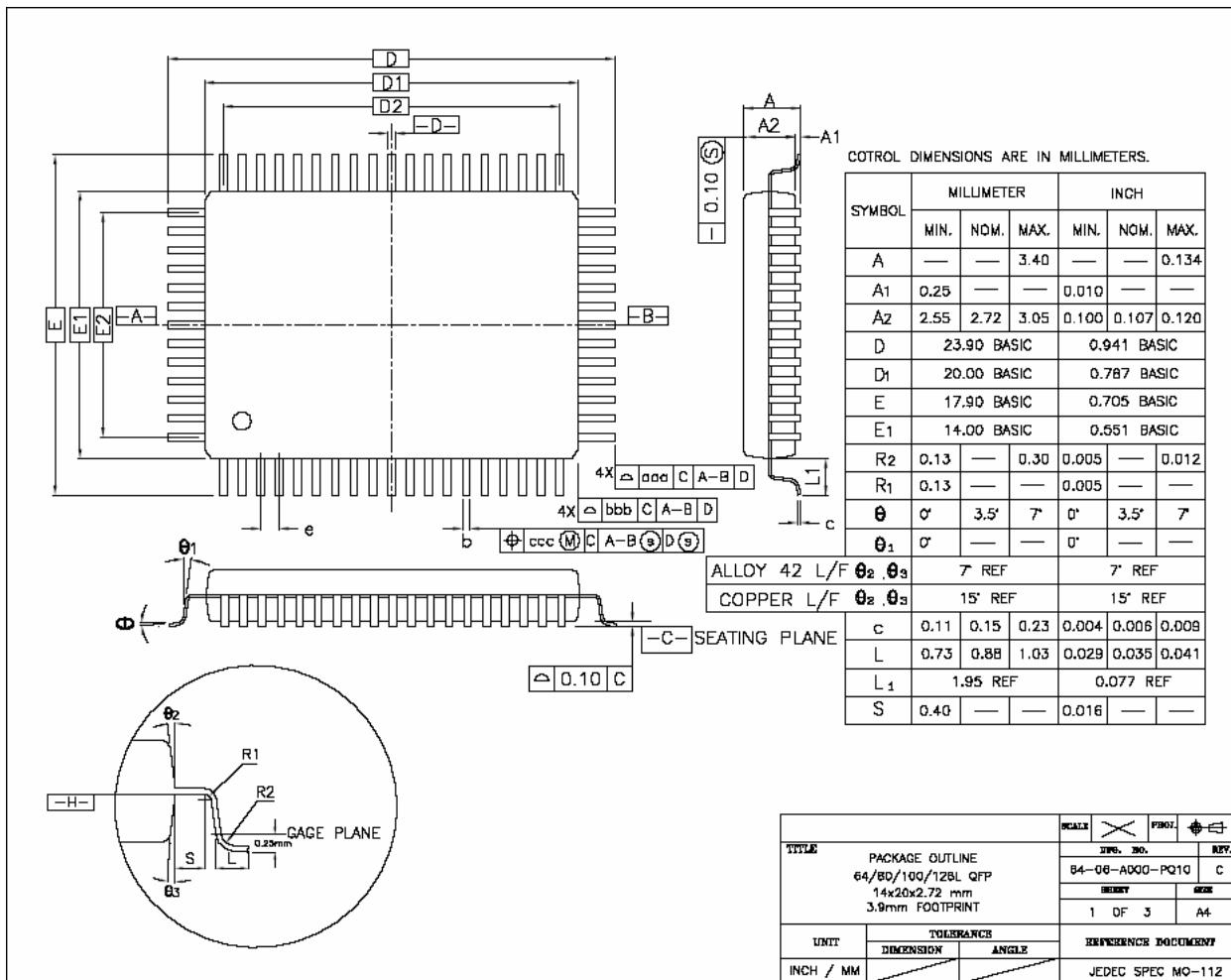

Dimensions in Millimeters

SYMBOL	80L		
	MILLIMETER		
	MIN.	NOM.	MAX.
b	0.30	0.35	0.45
e	0.80 BSC.		
D2	18.4 REF		
E2	12.0 REF		
TOLERANCE OF FORM AND POSITION			
aaa	0.25		
bbb	0.20		
ccc	0.20		

7. PIN CONFIGURATION(QFP80)

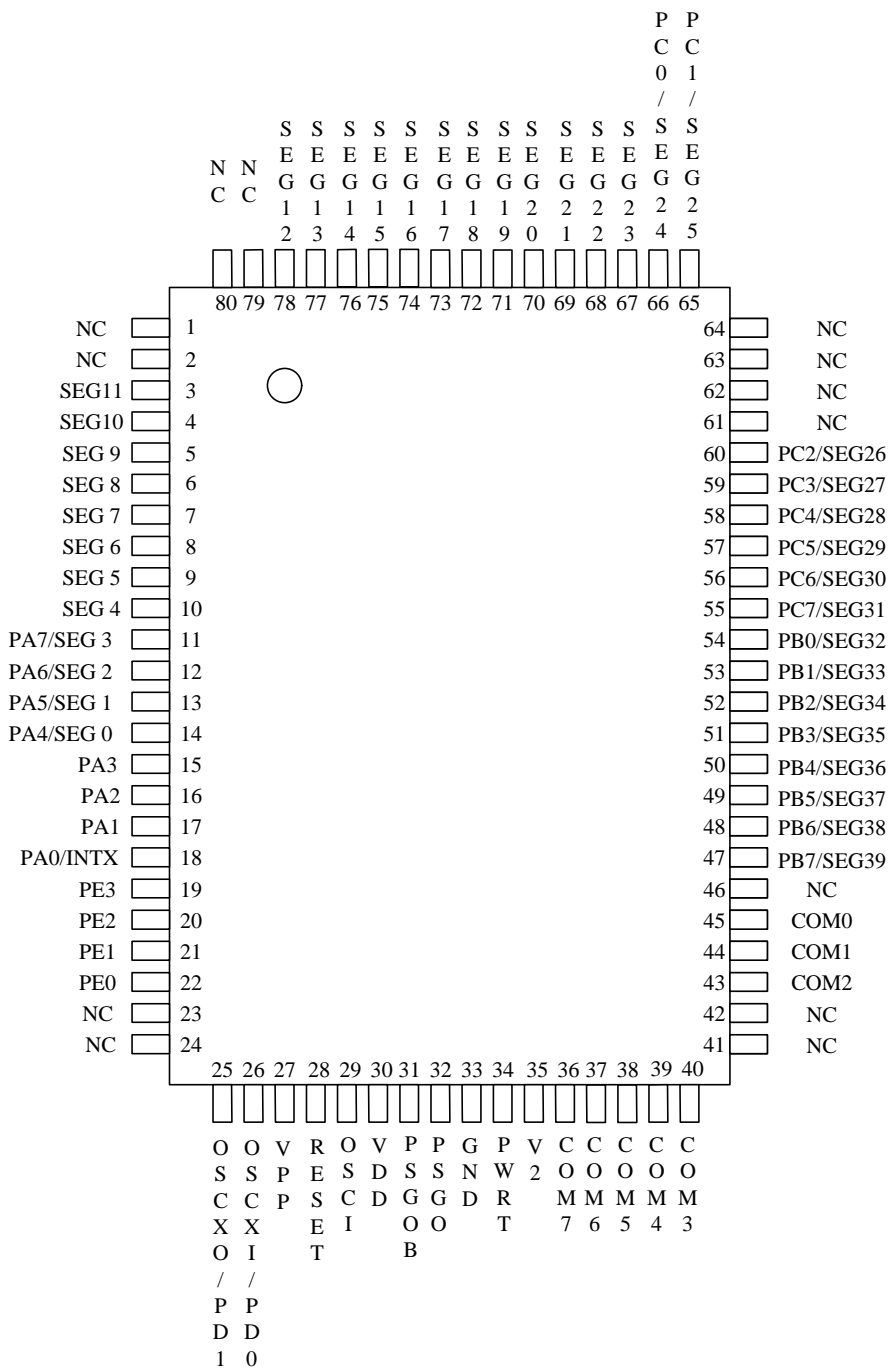

8. Application Circuits

8.1 APPLICATION CIRCUIT UNDER 3V OPERATING VOLTAGE

VDD : 3V
 Clock : 32768Hz crystal and 4.0MHz RC oscillator
 LCD : 1/8 duty
 I/O : PORT A
 ALARM : PSGO, PSGOB

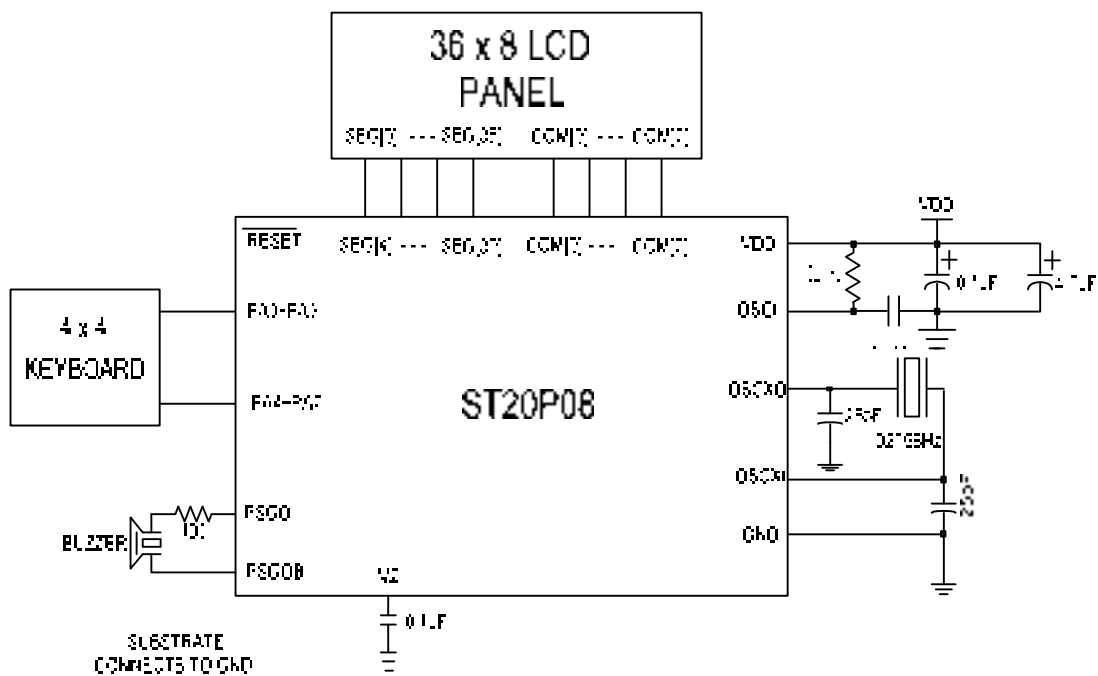

FIGURE 8-1: APPLICATION CIRCUIT WITHOUT LCD KEYBOARD AWAKING PULSE

VDD : 3V
 Clock : 32768Hz crystal and 4.0MHz RC oscillator
 LCD : 1/8 duty
 I/O : PORT A
 ALARM : PSGO, PSGOB

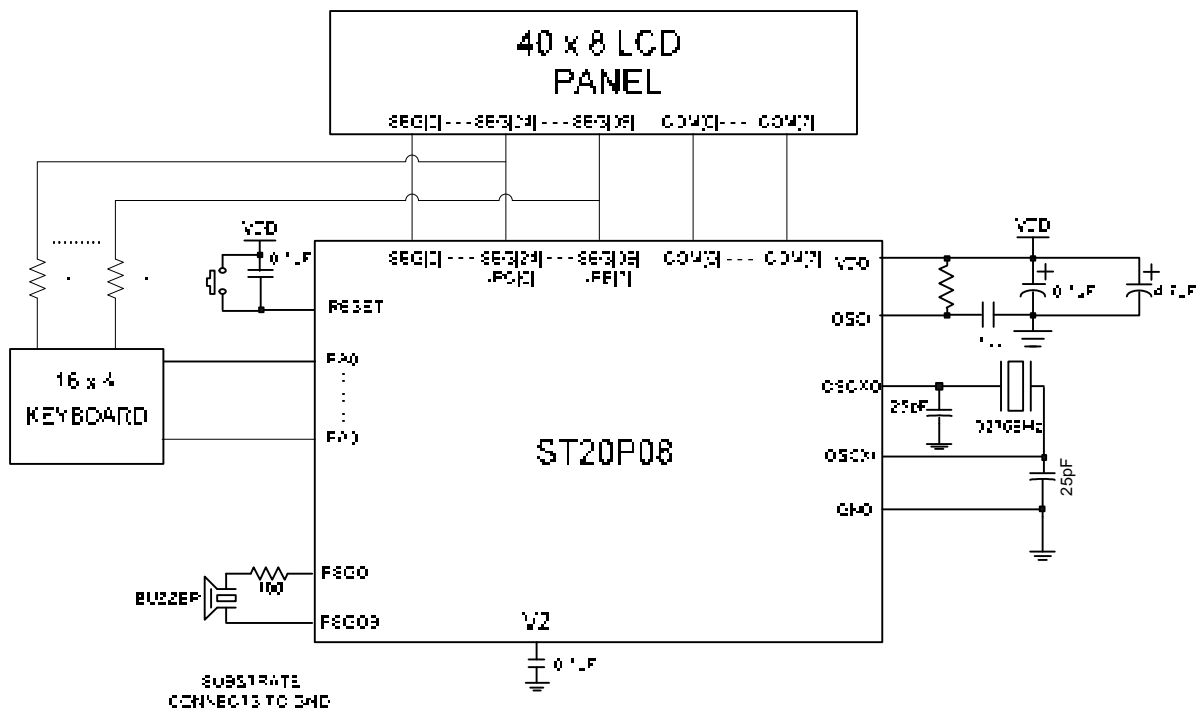

FIGURE 8-2: APPLICATION CIRCUIT WITH LCD KEYBOARD AWAKING PULSE

Note:

1. COMs and SEGs output GND level, while the LCD is turned off.
2. If LCD is turned off, Keyboard Awaking Pulses must be turned off at the same time.
3. Connect one capacitor of 100PF to OSCI stabilize oscillation frequency. This capacitor must be placed close to OSCI.

9. OTP ROM Programming Interface

9.1 Interface Description

In order to program OTP ROM, several pins have to be reserved on the PCB which is bounding with ST20P08. These total are 8 pins that include following list TABLE 9-1: . It just

be used to connect writer to program OTP ROM. After programming and disconnecting from writer, they can be used as original purpose.

TABLE 9-1: Pin assignment of interface

P18 Pad Name	(SPI Interface)	Pin Type	Description
VPP	VPP	Power	High Voltage Power Supply 1) OTP Program, Program Verify, VPP=> 12V 2) OTP Read:VPP=> Floating
GND	VSS	Power	Ground.
VCC	VDD	Power	Low Voltage (2.4V-5.4V) Power Supply.
PE3	SSB	Input	SPI signal
SEG4	MOSI	Input	SPI signal
SEG5	MISO	Output	SPI signal
PE2	SCK	Input	SPI signal
RESET	RESET	Input	SPI RESET

9.2 Programming Function Specification

There are reserved 5 option bits to select to apply or not the function we needed. It includes PD input, WDT enable, WDT stop at WAI-1 and Code Protection. To setup the

options should program the OTP ROM by OTP writer by control register. The register OTP(\$37) is used to read contents of the option word.

TABLE 9-2: Option ward

Bit 7	Bit 6	Bit 5	Bit 4	Bit 3	Bit 2	Bit 1	Bit 0	Default
CP	-	-	-	WDTSTP	WDTEN	-	PD	1--- 11-1

Bit 7: **CP**: OTP ROM code protect.
 0 =protect OTP data.
 1 =Un-Protect OTP data.

Bit 3: **WDTSTP**: WDT stop control bit.
 0 = WDT stop at WAI-1 and STP mode.
 1 = WDT is always active if WDTEEN is enabled.

Bit 2: **WDTEEN**: WDT enable.
 0 = WDT disable.
 1 = WDT enable.

Bit 0: **PD**: Port function selection
 0 = PD used as input port.
 1 = OSC input pin for 32768Hz crystal.

TABLE 9-3: OTP option ward read back window

Address	Name	R/W	Bit 7	Bit 6	Bit 5	Bit 4	Bit 3	Bit 2	Bit 1	Bit 0	Default
\$037	OPT	R	CP	-	-	PWRT	WDTSTP	WDTEN	-	PD	1--1 11-1

10. Power On Timer

The Power-on Timer (PWRT) is offered necessary delays on power-up to keep the chip in reset until the crystal oscillator is stable, the typical delay time in 3v at 25 °C is

32ms, and operation in voltage 2.4V~5.5V ,60 °C ~ -10°C is 4~640ms. The default state is high with one internal pull-up resistance.

TABLE 10-4: Power on timer pin option

IC pad	option	Description	Default
PWRT	0	disable power-on timer, tie to GND	1:input pull-up
	1	enable power-on timer, tie to VCC	

ST20P08 EVB PCB113-2



TABLE 10-5: The PCB 113-2 of ST20P08 EVB

11. Revisions

REVISION	DESCRIPTION	PAGE	DATE
01	First release	1~12	5/23/06
0.2	Add CPU clock 250K ~ 4MHz	1	6/23/06
0.3	Add EVB photo	12	5/23/07

The above information is the exclusive intellectual property of Sitronix Technology Corp. and shall not be disclosed, distributed or reproduced without permission from Sitronix. Sitronix Technology Corp. reserves the right to change this document without prior notice and makes no warranty for any errors which may appear in this document. Sitronix products are not intended for use in life support, critical care, medical, safety equipment, or similar applications where products failure could result in injury, or loss of life, or personal or physical harm, or any military or defense application, or any governmental procurement to which special terms or provisions may apply.