

TABLE OF CONTENTS

1	GENERAL DESCRIPTION.....	1
2	FEATURES	2
3	ORDERING INFORMATION	2
4	BLOCK DIAGRAM	3
5	DIE ARRANGEMENT	4
6	PIN DESCRIPTION	8
6.1	$\overline{\text{RES}}$	8
6.2	PS0-2.....	8
6.3	$\overline{\text{CS}}$	8
6.4	$\text{D}/\overline{\text{C}}$	8
6.5	$\text{R}/\overline{\text{W}}$ ($\overline{\text{WR}}$).....	8
6.6	$\text{E}(\overline{\text{RD}})$	8
6.7	D_0 - D_{15}	8
6.8	OSC1	9
6.9	REF	9
6.10	DV_{DD} , AV_{DD}	9
6.11	V_{DD}	9
6.12	DV_{SS} , AV_{SS}	9
6.13	V_{SS}	9
6.14	V_{Cl}	9
6.15	V_{CC}	9
6.16	$\text{C}_{1\text{P}}$, $\text{C}_{1\text{N}}$, $\text{C}_{3\text{P}}$, $\text{C}_{2\text{P}}$, $\text{C}_{2\text{N}}$, and $\text{C}_{4\text{P}}$	9
6.17	V_{L7}	9

6.18	V_{EXT}	9
6.19	$V_{L7}, V_{L6}, V_{L5}, V_{L4}, V_{L3}$ and V_{L2}	9
6.20	COM0 – COM159	10
6.21	SEG0 – SEG127	10
6.22	$C_{AP}, C_{AN}, C_{BP}, C_{BN}, C_{CP}, C_{CN}, C_{DP}$, and C_{DN}	10
6.23	N/C	10
7	FUNCTIONAL BLOCK DESCRIPTIONS	11
7.1	Command Decoder and Command Interface.....	11
7.2	MPU Parallel 6800-series Interface	11
7.3	MPU Parallel 8080-series Interface	11
7.4	MPU Serial 4-wire Interface.....	12
7.5	MPU Serial 3-wire interface.....	12
7.6	Graphic Display Data RAM (GDDRAM).....	12
7.7	Oscillator Circuit	12
7.8	LCD Driving Voltage Generator and Regulator	13
7.9	288 Bit Latch	13
7.10	Level selector	14
7.11	HV Buffer Cell (Level Shifter).....	14
7.12	Default Setting after Reset.....	15
7.13	Command Table.....	22
7.14	Read Status Byte	25
7.15	Data Read / Write	25
8	COMMAND DESCRIPTIONS	26
8.1	Set Lower Column Address [00~0F]	26
8.2	Set Higher Column Address [10~17]	26
8.3	Set Master/Slave Mode [18~19]	26
8.4	Set Internal Regulator Resistors Ratio [20~27]	26

8.5	Set Power Control Register [28~2F]	27
8.6	Set Display Start Line [40~43]	27
8.7	Set Display Offset [44~47]	27
8.8	Set Multiplex Ratio [48~4B]	27
8.9	Set N-line Inversion [4C~4F].....	28
8.10	Set LCD Bias [50~57].....	28
8.11	Set Upper Window Corner (ax, ay) [60~61]	28
8.12	Set Lower Window Corner (bx, by) [62~63]	28
8.13	Set DC-DC Converter Factor [64~67].....	28
8.14	Set Contrast Control Register [81].....	28
8.15	Set Gray Scale Mode (White/Light Gray/Dark Gray/Black) [88~8F]	28
8.16	Set Segment Re-map [A0~A1].....	29
8.17	Set Entire Display On/Off [A4~A5]	29
8.18	Set Normal/Reverse Display [A6~A7]	29
8.19	Set Power Save Mode [A9].....	29
8.20	Start Internal Oscillator [AB]	29
8.21	Set Display On/Off [AE~AF].....	29
8.22	Set Page Address [B0~BF]	29
8.23	Set COM Output Scan Direction [C0~CF].....	30
8.24	Exit Power Save Mode [E1].....	30
8.25	Software Reset [E2]	30
8.26	Exit N-line Inversion [E4]	30
8.27	Enable Scroll Buffer RAM [E6~E7].....	30
8.28	Set Display Data Length [E8].....	30
8.29	Set Temperature Coefficient (TC) Value [E9].....	30
8.30	Set Test Mode [F0~FF]	30
9	MAXIMUM RATINGS	31

10	DC CHARACTERISTICS	32
11	AC CHARACTERISTICS	34
12	APPLICATION CIRCUIT	38
12.1	DC-DC Converter Circuit Configuration	39
12.2	Bias Divider Circuit Configuration	39
12.3	Parallel Interface Configuration (Read / Write)	40
12.4	Serial Interface Configuration (Write Only)	40
13	APPENDIXA.....	41

TABLE OF FIGURES

Figure 1 - Block Diagram	3
Figure 2 - SSD1854Z Pin Assignment	4
Figure 3 - Display Data Read with the insertion of Dummy Read	11
Figure 4 - Oscillator Circuitry.....	13
Figure 5 - SSD1854 Graphic Display Data RAM (GDDRAM) Address Map	16
Figure 6 - Contrast Control Voltage Range Curve (TC=-0.1%/°C; V _{DD} =2.7V; V _{CI} =2.7V)	27
Figure 7 - Contrast Control Flow Set Segment Re-map	28
Figure 8 - Oscillation Frequency at different VDD at 25°C	34
Figure 9 - Parallel 6800-series Interface Timing Characteristics (PS0 = H, PS1 = H)	35
Figure 10 - Parallel 8080-series Interface Timing Characteristics (PS0 = H, PS1 = L)	36
Figure 11- Serial Timing Characteristics (PS0 = L)	37
Figure 12 - LCD Pins Connection of SSD1854Z.....	38
Figure 13 - SSD1854U COF Drawing 1	41
Figure 14 - SSD1854U COF Drawing 2.....	42

LIST OF TABLE

Table 1 - Ordering Information.....	2
Table 2 - SSD1854 Series Die Pad Coordinates	5
Table 3 - PS0-2 Interface	8
Table 4 - Modes of Operation	12
Table 5 - Command Table	22
Table 6 - Read Status Byte	25
Table 7 - Address Increment Table.....	25
Table 8 - Commands Required for R/W (WR#) Actions on RAM	25
Table 9 - Maximum Ratings	31
Table 10 - DC Characteristics	32
Table 11 - AC Characteristics	34
Table 12 - Parallel Timing Characteristics 1	35
Table 13 - Parallel Timing Characteristics 2	36
Table 14 - Serial Timing Characteristics	37

SSD1854

Advance Information

LCD Segment / Common Driver with Controller CMOS

1 General Description

SSD1854 is a single-chip CMOS 4 gray scale LCD driver with controller for liquid crystal dot-matrix graphic display system. It consists of 288 high voltage driving output pins for driving maximum 128 Segments and 160 Commons, customized for 2-sides COF modules.

SSD1854 displays data directly from its internal 128x176x2 bits Graphic Display Data RAM (GDDRAM). Data/Commands are sent from general MCU through a hardware selectable 6800-/8080-series compatible Parallel Interface or 3/4 wires Serial Peripheral Interface.

SSD1854 designed with multi-line-addressing (MLA) scheme to improve the display quality and reduce the system power consumption.

SSD1854 embeds a DC-DC Converter, a LCD Voltage Regulator, an On-Chip Bias Divider and an On-Chip oscillator, which reduce the number of external components. With the special design on minimizing power consumption and die/package layout, SSD1854 is suitable for any portable battery-driven applications requiring a long operation period and a compact size.

This document contains information on a new product. Specification and information herein are subject to change without notice.

2 FEATURES

- 128 x 160 4 gray-levels Graphic Display
- Programmable Multiplex ratio (partial display) [16Mux - 160Mux]
- Single Supply Operation, 1.8 V - 3.3V
- Low Current Sleep Mode (<1.0uA)
- On-Chip Voltage Generator / Regulator & Bias Dividers
- Software selectable 3X / 4X / 5X On-Chip DC-DC Converter
- On-Chip Oscillator
- Maximum +17.0V LCD Driving Output Voltage
- Hardware pin selectable for 8/16-bit 6800-series Parallel Interface, 8/16-bit 8080-series Parallel Interface, 3-wire Serial Peripheral Interface or 4-wire Serial Peripheral Interface
- Software Selectable On-Chip Bias Dividers
- On-Chip 128 x 176 x 2 Graphic Display Data RAM
- Re-mapping of Row and Column Drivers
- Programmable Window with Vertical Scrolling
- Display Offset Control
- 64 Levels Internal Contrast Control
- Maximum 17MHz SPI or 6MHz PPI operation
- Selectable LCD Driving Voltage Temperature Coefficients (4 settings) [-0.10%/°C (POR)]

3 ORDERING INFORMATION

Table 1 - Ordering Information

Ordering Part Number	Seg	Com	Package Form
SSD1854Z	128	160	Gold Bump Die
SSD1854U	128	160	Die on COF

4 BLOCK DIAGRAM

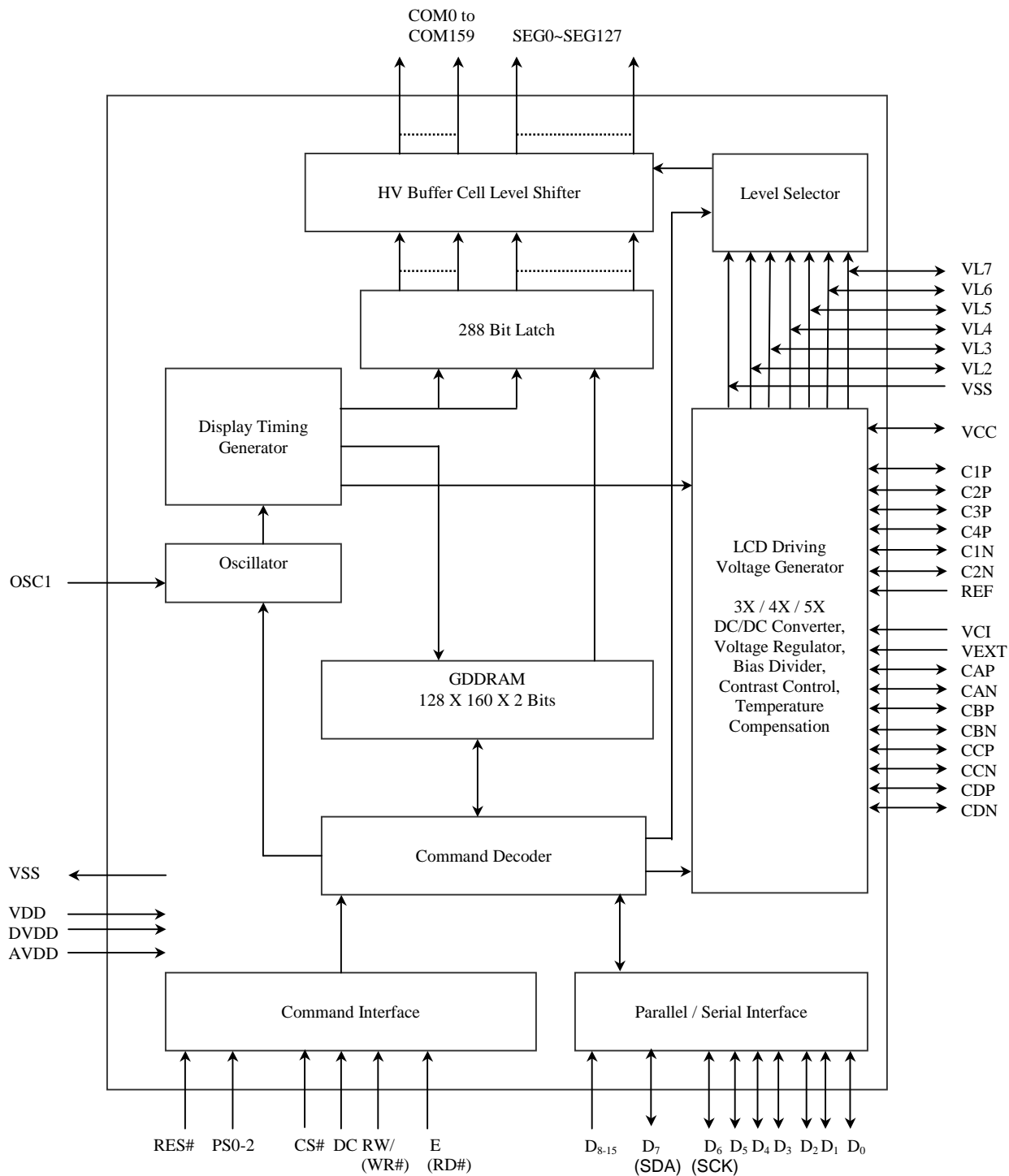
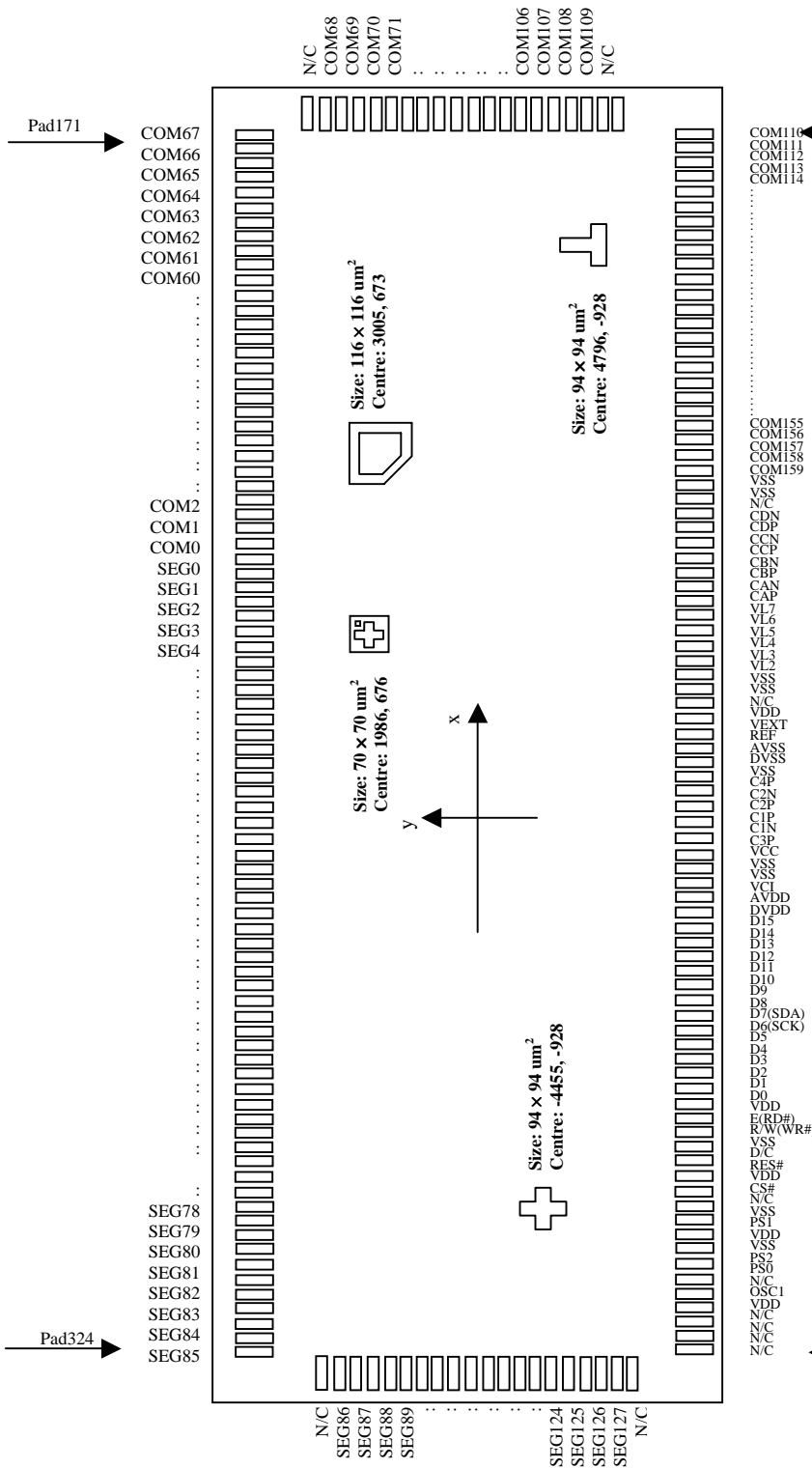

Figure 1 - Block Diagram

5 DIE Arrangement



COM116
COM111
COM112
COM113
COM114
COM115
COM155
COM156
COM157
COM158
COM159
VSS
N/C
CDN
CDP
CCN
CCP
CBN
CBP
CAN
CAP
VL7
VL6
VL5
VL4
VL3
VL2
VSS
VSS
N/C
VDD
VEXT
REF
DVSS
DVSS
VSS
C4P
C2N
C3P
C1P
C1N
C3P
VCC
VSS
VSS
VCL
AVDD
DVDD
D15
D14
D13
D12
D11
D10
D9
D8
D7(SDA)
D6(SCK)
D5
D4
D3
D2
D1
D0
VDD
E(RD#)
R(W)(WR#)
VSS
D/C
RES#
VDD
CS#
N/C
N/C
PS1
VDD
VSS
PS2
PS0
N/C
N/C
OSC1
VDD
N/C
N/C
N/C
N/C

- Note:**
1. Diagram showing the die face up.
 2. Coordinates are reference to center of the chip.
 3. Unit of coordinates and Size of all alignment marks are in um.
 4. All alignment keys do not contain gold bump.

Chip Size	X	Y	Unit
	10.72	2.77	mm
Chip Thickness	723.9 ± 25		µm
Bump Size	Pad #	X	Y
	1 - 4		
	43 - 51	40	70
	59 - 75		
	77 - 126		
	171 - 324		
Bump Height	5 - 42	50	60
	52 - 58		
	76		
Bump Height	127 - 170	70	40
	325 - 368		
Bump Height	18 (Typ.)		µm

Figure 2 – SSD1854Z Pin Assignment

Table 2 - SSD1854 Series Die Pad Coordinates

Pad #	Pad Name	X-pos	Y-pos	Pad #	Pad Name	X-pos	Y-pos	Pad #	Pad Name	X-pos	Y-pos
1	N/C	-4520.2	-1239.7	51	VSS	-287.1	-1239.7	101	COM135	3223.1	-1214.3
2	N/C	-4451.6	-1239.7	52	DVSS	-206.0	-1243.7	102	COM134	3282.5	-1214.3
3	N/C	-4383.0	-1239.7	53	AVSS	-106.7	-1243.7	103	COM133	3341.9	-1214.3
4	N/C	-4314.4	-1239.7	54	REF	-7.5	-1243.7	104	COM132	3401.3	-1214.3
5	VDD	-4233.3	-1243.7	55	VEXT	81.6	-1243.7	105	COM131	3460.7	-1214.3
6	OSC1	-4144.2	-1243.7	56	VDD	170.7	-1243.7	106	COM130	3520.1	-1214.3
7	N/C	-4055.1	-1243.7	57	N/C	259.8	-1243.7	107	COM129	3579.5	-1214.3
8	PS0	-3966.0	-1243.7	58	VSS	348.9	-1243.7	108	COM128	3638.9	-1214.3
9	PS2	-3876.9	-1243.7	59	VSS	430.0	-1239.7	109	COM127	3698.3	-1214.3
10	VSS	-3787.8	-1243.7	60	VL2	499.4	-1239.7	110	COM126	3757.7	-1214.3
11	VDD	-3698.7	-1243.7	61	VL3	568.0	-1239.7	111	COM125	3817.1	-1214.3
12	PS1	-3609.6	-1243.7	62	VL4	636.6	-1239.7	112	COM124	3876.5	-1214.3
13	VSS	-3520.5	-1243.7	63	VL5	705.2	-1239.7	113	COM123	3935.9	-1214.3
14	N/C	-3431.4	-1243.7	64	VL6	773.8	-1239.7	114	COM122	3995.3	-1214.3
15	\overline{CS}	-3342.3	-1243.7	65	VL7	868.4	-1239.7	115	COM121	4054.7	-1214.3
16	VDD	-3253.2	-1243.7	66	CAP	963.0	-1239.7	116	COM120	4114.1	-1214.3
17	\overline{RES}	-3164.1	-1243.7	67	CAN	1031.6	-1239.7	117	COM119	4173.5	-1214.3
18	$\overline{D/C}$	-3075.0	-1243.7	68	CBP	1100.3	-1239.7	118	COM118	4232.9	-1214.3
19	VSS	-2985.9	-1243.7	69	CBN	1168.8	-1239.7	119	COM117	4292.3	-1214.3
20	R/W (\overline{WR})	-2896.8	-1243.7	70	CCP	1237.4	-1239.7	120	COM116	4351.7	-1214.3
21	$\overline{E(RD)}$	-2807.7	-1243.7	71	CCN	1306.0	-1239.7	121	COM115	4411.1	-1214.3
22	VDD	-2718.6	-1243.7	72	CDP	1374.6	-1239.7	122	COM114	4470.5	-1214.3
23	D0	-2629.5	-1243.7	73	CDN	1443.2	-1239.7	123	COM113	4529.9	-1214.3
24	D1	-2540.4	-1243.7	74	N/C	1511.8	-1239.7	124	COM112	4589.3	-1214.3
25	D2	-2451.3	-1243.7	75	VSS	1580.4	-1239.7	125	COM111	4648.7	-1214.3
26	D3	-2362.2	-1243.7	76	VSS	1661.5	-1243.7	126	COM110	4708.1	-1214.3
27	D4	-2273.1	-1243.7	77	COM159	1797.5	-1214.3	127	N/C	5192.1	-1277.1
28	D5	-2184.0	-1243.7	78	COM158	1856.9	-1214.3	128	COM109	5192.1	-1217.7
29	D6 (SCK)	-2094.9	-1243.7	79	COM157	1916.3	-1214.3	129	COM108	5192.1	-1158.3
30	D7 (SDA)	-2005.8	-1243.7	80	COM156	1975.7	-1214.3	130	COM107	5192.1	-1098.9
31	D8	-1916.7	-1243.7	81	COM155	2035.1	-1214.3	131	COM106	5192.1	-1039.5
32	D9	-1827.6	-1243.7	82	COM154	2094.5	-1214.3	132	COM105	5192.1	-980.1
33	D10	-1738.5	-1243.7	83	COM153	2153.9	-1214.3	133	COM104	5192.1	-920.7
34	D11	-1649.4	-1243.7	84	COM152	2213.3	-1214.3	134	COM103	5192.1	-861.3
35	D12	-1560.3	-1243.7	85	COM151	2272.7	-1214.3	135	COM102	5192.1	-801.9
36	D13	-1471.2	-1243.7	86	COM150	2332.1	-1214.3	136	COM101	5192.1	-742.5
37	D14	-1382.1	-1243.7	87	COM149	2391.5	-1214.3	137	COM100	5192.1	-683.1
38	D15	-1293.0	-1243.7	88	COM147	2450.9	-1214.3	138	COM99	5192.1	-623.7
39	DVDD	-1203.9	-1243.7	89	COM147	2510.3	-1214.3	139	COM98	5192.1	-564.3
40	AVDD	-1104.7	-1243.7	90	COM146	2569.7	-1214.3	140	COM97	5192.1	-504.9
41	VCI	-1005.5	-1243.7	91	COM145	2629.1	-1214.3	141	COM96	5192.1	-445.5
42	VSS	-916.4	-1243.7	92	COM144	2688.5	-1214.3	142	COM95	5192.1	-386.1
43	VSS	-835.9	-1239.7	93	COM143	2747.9	-1214.3	143	COM94	5192.1	-326.7
44	VCC	-767.3	-1239.7	94	COM142	2807.3	-1214.3	144	COM93	5192.1	-267.3
45	C3P	-698.7	-1239.7	95	COM141	2866.7	-1214.3	145	COM92	5192.1	-207.9
46	C1N	-630.1	-1239.7	96	COM140	2926.1	-1214.3	146	COM91	5192.1	-148.5
47	C1P	-561.5	-1239.7	97	COM139	2985.5	-1214.3	147	COM90	5192.1	-89.1
48	C2P	-492.9	-1239.7	98	COM138	3044.9	-1214.3	148	COM89	5192.1	-29.7
49	C2N	-424.3	-1239.7	99	COM137	3104.3	-1214.3	149	COM88	5192.1	29.7
50	C4P	-355.7	-1239.7	100	COM136	3163.7	-1214.3	150	COM87	5192.1	89.1

Pad #	Pad Name	X-pos	Y-pos	Pad #	Pad Name	X-pos	Y-pos	Pad #	Pad Name	X-pos	Y-pos
151	COM86	5192.1	148.5	201	COM37	2926.1	1214.3	251	SEG12	-162.7	1214.3
152	COM85	5192.1	207.9	202	COM36	2866.7	1214.3	252	SEG13	-222.1	1214.3
153	COM84	5192.1	267.3	203	COM35	2807.3	1214.3	253	SEG14	-281.5	1214.3
154	COM83	5192.1	326.7	204	COM34	2747.9	1214.3	254	SEG15	-340.9	1214.3
155	COM82	5192.1	386.1	205	COM33	2688.5	1214.3	255	SEG16	-400.3	1214.3
156	COM81	5192.1	445.5	206	COM32	2629.1	1214.3	256	SEG17	-459.7	1214.3
157	COM80	5192.1	504.9	207	COM31	2569.7	1214.3	257	SEG18	-519.1	1214.3
158	COM79	5192.1	564.3	208	COM30	2510.3	1214.3	258	SEG19	-578.5	1214.3
159	COM78	5192.1	623.7	209	COM29	2450.9	1214.3	259	SEG20	-637.9	1214.3
160	COM77	5192.1	683.1	210	COM28	2391.5	1214.3	260	SEG21	-697.3	1214.3
161	COM76	5192.1	742.5	211	COM27	2332.1	1214.3	261	SEG22	-756.7	1214.3
162	COM75	5192.1	801.9	212	COM26	2272.7	1214.3	262	SEG23	-816.1	1214.3
163	COM74	5192.1	861.3	213	COM25	2213.3	1214.3	263	SEG24	-875.5	1214.3
164	COM73	5192.1	920.7	214	COM24	2153.9	1214.3	264	SEG25	-934.9	1214.3
165	COM72	5192.1	980.1	215	COM23	2094.5	1214.3	265	SEG26	-994.3	1214.3
166	COM71	5192.1	1039.5	216	COM22	2035.1	1214.3	266	SEG27	-1053.7	1214.3
167	COM70	5192.1	1098.9	217	COM21	1975.7	1214.3	267	SEG28	-1113.1	1214.3
168	COM69	5192.1	1158.3	218	COM20	1916.3	1214.3	268	SEG29	-1172.5	1214.3
169	COM68	5192.1	1217.7	219	COM19	1856.9	1214.3	269	SEG30	-1231.9	1214.3
170	N/C	5192.1	1277.1	220	COM18	1797.5	1214.3	270	SEG31	-1291.3	1214.3
171	COM67	4708.1	1214.3	221	COM17	1738.1	1214.3	271	SEG32	-1350.7	1214.3
172	COM66	4648.7	1214.3	222	COM16	1678.7	1214.3	272	SEG33	-1410.1	1214.3
173	COM65	4589.3	1214.3	223	COM15	1619.3	1214.3	273	SEG34	-1469.5	1214.3
174	COM64	4529.9	1214.3	224	COM14	1559.9	1214.3	274	SEG35	-1528.9	1214.3
175	COM63	4470.5	1214.3	225	COM13	1500.5	1214.3	275	SEG36	-1588.3	1214.3
176	COM62	4411.1	1214.3	226	COM12	1441.1	1214.3	276	SEG37	-1647.7	1214.3
177	COM61	4351.7	1214.3	227	COM11	1381.7	1214.3	277	SEG38	-1707.1	1214.3
178	COM60	4292.3	1214.3	228	COM10	1322.3	1214.3	278	SEG39	-1766.5	1214.3
179	COM59	4232.9	1214.3	229	COM9	1262.9	1214.3	279	SEG40	-1825.9	1214.3
180	COM58	4173.5	1214.3	230	COM8	1203.5	1214.3	280	SEG41	-1885.3	1214.3
181	COM57	4114.1	1214.3	231	COM7	1144.1	1214.3	281	SEG42	-1944.7	1214.3
182	COM56	4054.7	1214.3	232	COM6	1084.7	1214.3	282	SEG43	-2004.1	1214.3
183	COM55	3995.3	1214.3	233	COM5	1025.3	1214.3	283	SEG44	-2063.5	1214.3
184	COM54	3935.9	1214.3	234	COM4	965.9	1214.3	284	SEG45	-2122.9	1214.3
185	COM53	3876.5	1214.3	235	COM3	906.5	1214.3	285	SEG46	-2182.3	1214.3
186	COM52	3817.1	1214.3	236	COM2	847.1	1214.3	286	SEG47	-2241.7	1214.3
187	COM51	3757.7	1214.3	237	COM1	787.7	1214.3	287	SEG48	-2301.1	1214.3
188	COM50	3698.3	1214.3	238	COM0	728.3	1214.3	288	SEG49	-2360.5	1214.3
189	COM49	3638.9	1214.3	239	SEG0	550.1	1214.3	289	SEG50	-2419.9	1214.3
190	COM48	3579.5	1214.3	240	SEG1	490.7	1214.3	290	SEG51	-2479.3	1214.3
191	COM47	3520.1	1214.3	241	SEG2	431.3	1214.3	291	SEG52	-2538.7	1214.3
192	COM46	3460.7	1214.3	242	SEG3	371.9	1214.3	292	SEG53	-2598.1	1214.3
193	COM45	3401.3	1214.3	243	SEG4	312.5	1214.3	293	SEG54	-2657.5	1214.3
194	COM44	3341.9	1214.3	244	SEG5	253.1	1214.3	294	SEG55	-2716.9	1214.3
195	COM43	3282.5	1214.3	245	SEG6	193.7	1214.3	295	SEG56	-2776.3	1214.3
196	COM42	3223.1	1214.3	246	SEG7	134.3	1214.3	296	SEG57	-2835.7	1214.3
197	COM41	3163.7	1214.3	247	SEG8	74.9	1214.3	297	SEG58	-2895.1	1214.3
198	COM40	3104.3	1214.3	248	SEG9	15.5	1214.3	298	SEG59	-2954.5	1214.3
199	COM39	3044.9	1214.3	249	SEG10	-43.9	1214.3	299	SEG60	-3013.9	1214.3
200	COM38	2985.5	1214.3	250	SEG11	-103.3	1214.3	300	SEG61	-3073.3	1214.3

Pad #	Pad Name	X-pos	Y-pos	Pad #	Pad Name	X-pos	Y-pos
301	SEG62	-3132.7	1214.3	351	SEG111	-5192.1	-267.3
302	SEG63	-3192.1	1214.3	352	SEG112	-5192.1	-326.7
303	SEG64	-3251.5	1214.3	353	SEG113	-5192.1	-386.1
304	SEG65	-3310.9	1214.3	354	SEG114	-5192.1	-445.5
305	SEG66	-3370.3	1214.3	355	SEG115	-5192.1	-504.9
306	SEG67	-3429.7	1214.3	356	SEG116	-5192.1	-564.3
307	SEG68	-3489.1	1214.3	357	SEG117	-5192.1	-623.7
308	SEG69	-3548.5	1214.3	358	SEG118	-5192.1	-683.1
309	SEG70	-3607.9	1214.3	359	SEG119	-5192.1	-742.5
310	SEG71	-3667.3	1214.3	360	SEG120	-5192.1	-801.9
311	SEG72	-3726.7	1214.3	361	SEG121	-5192.1	-861.3
312	SEG73	-3786.1	1214.3	362	SEG122	-5192.1	-920.7
313	SEG74	-3845.5	1214.3	363	SEG123	-5192.1	-980.1
314	SEG75	-3904.9	1214.3	364	SEG124	-5192.1	-1039.5
315	SEG76	-3964.3	1214.3	365	SEG125	-5192.1	-1098.9
316	SEG77	-4023.7	1214.3	366	SEG126	-5192.1	-1158.3
317	SEG78	-4083.1	1214.3	367	SEG127	-5192.1	-1217.7
318	SEG79	-4142.5	1214.3	368	N/C	-5192.1	-1277.1
319	SEG80	-4201.9	1214.3				
320	SEG81	-4261.3	1214.3				
321	SEG82	-4320.7	1214.3				
322	SEG83	-4380.1	1214.3				
323	SEG84	-4439.5	1214.3				
324	SEG85	-4498.9	1214.3				
325	N/C	-5192.1	1277.1				
326	SEG86	-5192.1	1217.7				
327	SEG87	-5192.1	1158.3				
328	SEG88	-5192.1	1098.9				
329	SEG89	-5192.1	1039.5				
330	SEG90	-5192.1	980.1				
331	SEG91	-5192.1	920.7				
332	SEG92	-5192.1	861.3				
333	SEG93	-5192.1	801.9				
334	SEG94	-5192.1	742.5				
335	SEG95	-5192.1	683.1				
336	SEG96	-5192.1	623.7				
337	SEG97	-5192.1	564.3				
338	SEG98	-5192.1	504.9				
339	SEG99	-5192.1	445.5				
340	SEG100	-5192.1	386.1				
341	SEG101	-5192.1	326.7				
342	SEG102	-5192.1	267.3				
343	SEG103	-5192.1	207.9				
344	SEG104	-5192.1	148.5				
345	SEG105	-5192.1	89.1				
346	SEG106	-5192.1	29.7				
347	SEG107	-5192.1	-29.7				
348	SEG108	-5192.1	-89.1				
349	SEG109	-5192.1	-148.5				
350	SEG110	-5192.1	-207.9				

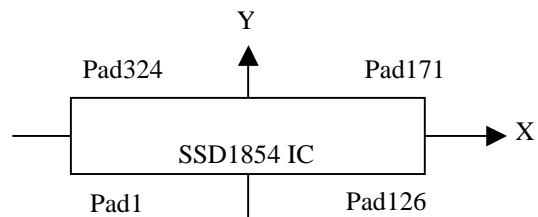

Pad Pitch	Pad #	Diff.	Unit
	1 - 4 43 - 51 60 - 64 66 - 75	68.6	μm
4 - 5 51 - 52 58 - 59 75 - 76	81.1		
5 - 39 41 - 42 54 - 58	89.1		
39 - 41 53 - 54	99.2		
42 - 43	80.6		
52 - 53	99.3		
59 - 60	69.5		
64 - 66	94.6		
76 - 77	136		
77 - 126 127 - 170 171 - 238 239 - 324 325 - 368 238 - 239	59.4		
238 - 239	178.2		
Pad Space	19.4 (min)	μm	

6 PIN DESCRIPTION

6.1 $\overline{\text{RES}}$

This pin is reset signal input. When the pin is low, initialization of the chip is executed.

6.2 PS0-2

These 3 pins use together to determine the interface protocol between the driver and MCU according to the following table.

Table 3 - PS0-2 Interface

PS0	PS1	PS2	Interface
L	L	X	3-wire SPI (write only)
L	H	X	4-wire SPI (write only)
H	L	H	8080 parallel interface (8-bits read and 16-bits write)
		L	8080 parallel interface (8-bits read and 8-bits write)
H	H	H	6800 parallel interface (8-bits read and 16-bits write)
		L	6800 parallel interface (8-bits read and 8-bits write)

6.3 $\overline{\text{CS}}$

This pin is chip select input. The chip is enabled for display data/command transfer only when $\overline{\text{CS}}$ is low.

For 6800-series parallel mode, when E pin is pulled high, the read/write cycle is initiated by pulling low of this $\overline{\text{CS}}$ pin.

6.4 $\text{D}/\overline{\text{C}}$

This input pin is to identify display data/command cycle. When the pin is high, the data written to the driver will be written into display RAM. When the pin is low, the data will be interpreted as command. This pin must be connected to V_{SS} when 3-lines SPI interface is used.

6.5 $\text{R}/\overline{\text{W}}$ ($\overline{\text{WR}}$)

This pin is microprocessor interface signal. When interfacing to an 6800-series microprocessor, the signal indicates read mode when high and write mode when low. When interfacing to an 8080-microprocessor, a data write operation is initiated when $\text{R}/\overline{\text{W}}$ ($\overline{\text{WR}}$) is low and the chip is selected.

6.6 $\text{E}(\overline{\text{RD}})$

This pin is microprocessor interface signal. When interfacing to an 6800-series microprocessor, a data operation is initiated when $\text{E}(\overline{\text{RD}})$ is high and the chip is selected. When interfacing to an 8080-microprocessor, a data read operation is initiated when $\text{E}(\overline{\text{RD}})$ is low and the chip is selected.

6.7 D_0 - D_{15}

D_0 - D_7 are bi-directional and D_8 - D_{15} are input only data pins to be connected to the microprocessor's data bus. When serial mode is selected, D_7 is the serial data input SDA and D_6 is the serial clock input SCK. All unused data pins must be connected to ground.

6.8 OSC1

This pin is for oscillator frequency selection. A resistor must be connected between this pin and V_{DD} when using the internal oscillator. The suggested value of the resistor is 680K ohm. Please refer to the Figure 8 for details.

6.9 REF

This pin is an input pin to enable the internal reference voltage used for the internal regulator. When it is high, an internal reference voltage source will be used. When it is low, and external reference must be provided in V_{EXT} .

6.10 DV_{DD}, AV_{DD}

Digital and Analog power supply pins, must be connected to same external source.

6.11 V_{DD}

Internally connected to DV_{DD} for pull high purpose. Can be connected to DVDD externally or float.

6.12 DV_{SS}, AV_{SS}

Digital and Analog ground, must be connected to external ground.

6.13 V_{SS}

Internally connected to DV_{SS} for pull low purpose.

6.14 V_{CI}

Reference voltage input for internal DC-DC converter. The voltage of generated V_{CC} equals to the multiple factor (3X, 4X or 5X) times V_{CI} with respect to V_{SS} .

Note: Voltage at this input pin must be larger than or equal to AV_{DD} and DV_{DD}.

6.15 V_{CC}

Voltage at this pin must be greater than $V_{L4} + 2V$. It can be supplied externally or generated by the internal DC-DC converter.

When using internal DC-DC converter as generator, voltage at this pin is for internal reference only. It CANNOT be used for driving external circuitries.

6.16 C_{1P}, C_{1N}, C_{3P}, C_{2P}, C_{2N}, and C_{4P}

When internal DC-DC voltage converter is used, external capacitor(s) is/are connected among these pins.

6.17 V_{L7}

This pin is the most positive LCD driving voltage. It can be generated by the internal regulator or supply externally when internal regulator and divider are turned off.

6.18 V_{EXT}

This pin is an input to provide an external voltage reference for the internal voltage regulator when REF pin is pulled low.

6.19 V_{L7}, V_{L6}, V_{L5}, V_{L4}, V_{L3} and V_{L2}

LCD driving voltages. They can be supplied externally or generated by the internal regulator and divider or supplied externally when regulator and divider are turned off. They have the following relationship:

$$V_{L7} > V_{L6} > V_{L5} > V_{L4} > V_{L3} > V_{L2} > V_{SS}$$

6.20 COM0 – COM159

These pins provide the row driving signal COM0 – COM159 to the LCD panel.

6.21 SEG0 – SEG127

These pins provide the LCD column driving signal. Their voltage level is V_{SS} during sleep mode.

6.22 C_{AP}, C_{AN}, C_{BP}, C_{BN}, C_{CP}, C_{CN}, C_{DP}, and C_{DN}

These pins are connected to four capacitors when internal divider is enabled.

6.23 N/C

These No Connection pins should NOT be connected to any signals nor shorted together. These N/C pins should be left open.

7 FUNCTIONAL BLOCK DESCRIPTIONS

7.1 Command Decoder and Command Interface

This module determines whether the input data is interpreted as data or command. Data is directed to this module based upon the input of the D/\bar{C} pin. If D/\bar{C} is high, data is written to Graphic Display Data RAM (GDDRAM). If D/\bar{C} is low, the input at D_0 - D_{15} is interpreted as a Command and it will be decoded and written to the corresponding command register.

Reset is of the same function as Power ON Reset (POR). Once \bar{RES} receives a negative reset pulse of about 1us, all internal circuitry will be back to its initial status. Refer to Command Description section for more information.

7.2 MPU Parallel 6800-series Interface

The parallel interface consists of 8/16 data pins ($D_0 - D_{15}$), $R/\bar{W}(\bar{WR})$, D/\bar{C} , $E(\bar{RD})$ and \bar{CS} . $R/\bar{W}(\bar{WR})$ input High indicates a read operation from the Graphic Display Data RAM (GDDRAM) or the status register. $R/\bar{W}(\bar{WR})$ input Low indicates a write operation to Display Data RAM or Internal Command Registers depending on the status of D/\bar{C} input. The $E(\bar{RD})$ and \bar{CS} input serves as data latch signal (clock) when they are high and low respectively. Refer to Figure 9 of parallel timing characteristics for Parallel Interface Timing Diagram of 6800-series microprocessors.

In order to match the operating frequency of display RAM with that of the microprocessor, some pipeline processing is internally performed which requires the insertion of a dummy read before the first actual display data read. This is shown in Figure 3 below.

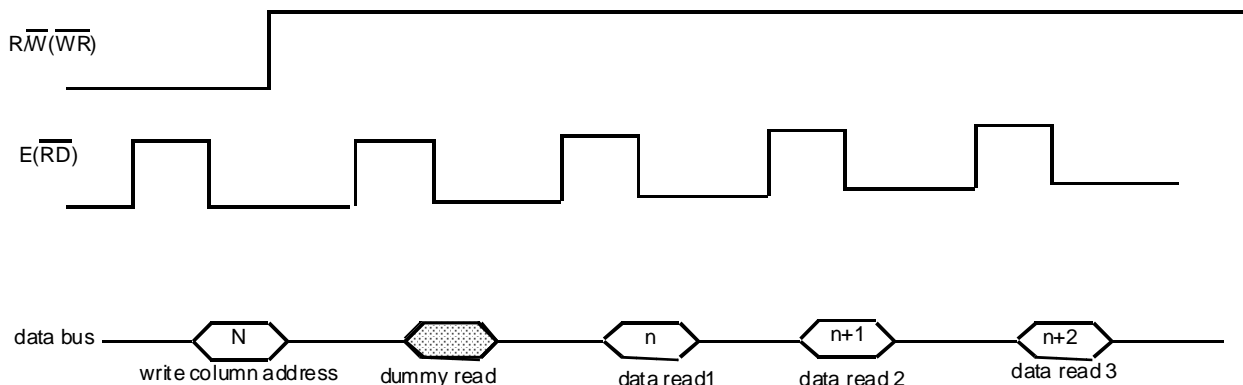

Figure 3 – Display Data Read with the insertion of Dummy Read

7.3 MPU Parallel 8080-series Interface

The parallel interface consists of 8/16 data pins (D_0 - D_{15}), $R/\bar{W}(\bar{WR})$, $E(\bar{RD})$, D/\bar{C} and \bar{CS} . The \bar{CS} input serves as data latch signal (clock) when it is low. Whether it is display data or status register read is controlled by D/\bar{C} . $R/\bar{W}(\bar{WR})$ and $E(\bar{RD})$ input indicates a write or read cycle when \bar{CS} is low. Refer to Figure 10 of parallel timing characteristics for Parallel Interface Timing Diagram of 8080-series microprocessor.

Similar to 6800-series interface, a dummy read is also required before the first actual display data read.

7.4 MPU Serial 4-wire Interface

The serial interface consists of serial clock SCK, serial data SDA, D/\bar{C} and \bar{CS} . SDA is shifted into an 8-bit shift register on every rising edge of SCL in the order of $D_7, D_6, \dots D_0$. D/\bar{C} is sampled on every eighth clock and the data byte in the shift register is written to the Display Data RAM or command register in the same clock. No extra clock or command is required to end the transmission.

7.5 MPU Serial 3-wire interface

Operation is similar to 4-wire serial interface while D/\bar{C} is not been used. The Display Data Length instruction is used to indicate that a specified number display data byte(s) (1-256) are to be transmitted. Next byte after the display data string is handled as a command.

It should be noted that if there is a signal glitch at SCK that causing an out of synchronization in the serial communication, a hardware reset pulse at \bar{RES} pin is required to initialize the chip for re-synchronization.

Table 4 -Modes of Operation

	6800 Parallel	8080 Parallel	Serial
Data Read	8-bitys	8-bits	No
Data Write	8/16-bits	8/16-bits	8-bits
Command Read	Status only	Status only	No
Command Write	Yes	Yes	Yes

7.6 Graphic Display Data RAM (GDDRAM)

The GDDRAM is a bit mapped static RAM holding the bit pattern to be displayed. The size of the RAM is $128 \times 176 \times 2 = 45,056$ bits.

Figure 5 is a description of the GDDRAM address map. For mechanical flexibility, re-mapping on both Segment and Common outputs are provided. For vertical scrolling of display, an internal register storing the display start line can be set to control the portion of the RAM data to be mapped to the display.

Figure 5 shows the case in which the display start line register is set at 30H. For those GDDRAM out of the display common range, they could still be accessed, for either preparation of vertical scrolling data or even for the system usage.

7.7 Oscillator Circuit

This module is an On-Chip low power RC oscillator circuitry (Figure 4). The oscillator generates the clock for the DC-DC voltage converter. This clock is also used in the Display Timing Generator.

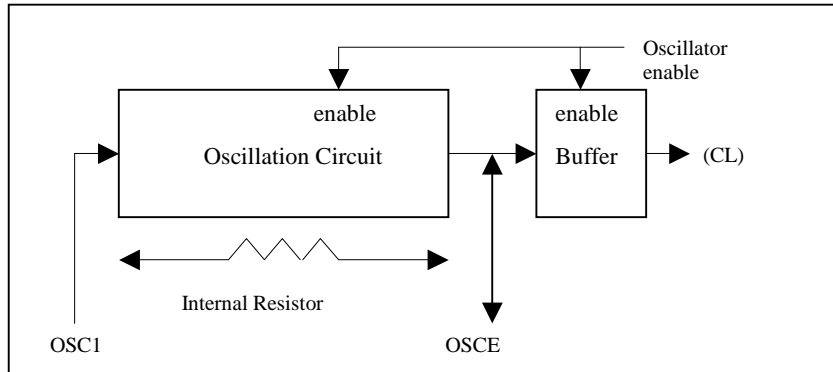

Figure 4 - Oscillator Circuitry

7.8 LCD Driving Voltage Generator and Regulator

This module generates the LCD voltage needed for display output. It takes a single supply input and generates necessary bias voltages.

It consists of:

1. 3X, 4X and 5X DC-DC voltage converter:
The booster output at V_{CC} equals to n time V_{CI} where n is the booster ration. The V_{CC} voltage must be greater than $2V + VL4$ or $2V + \frac{1}{2} VL7$. Please refer to application notes for details.
2. Voltage Regulator
Feedback gain control for initial LCD voltage. Internal resistors are connected between V_{SS} and V_R (internal contrast voltage reference), and between V_R and V_{L7} . These resistors are chosen to give the desired V_{L7} according to the following equation:

$$V_{L7} = \left(1 + \frac{R2}{R1}\right) \times V_{con} \quad \text{and} \quad V_{con} = \left(1 - \frac{(63 - \alpha)}{210}\right) \times V_{ref}$$

where:

V_{ref} is the internally generated reference voltage
 $(1+R2/R1)$ is the software programmable IRS value
 α is the software contrast level from 0 to 63

3. Bias Divider
There is an on-chip bias divider inside the chip selected by software which generate all $V_{L2} \sim V_{L7}$ levels automatically.
4. Contrast Control
Software control of 64 voltage levels of LCD voltage.
5. Bias Ratio Selection circuitry
Software control of different bias ratios to match the characteristic of LCD panel.
6. Self adjust temperature compensation circuitry
Provide 4 different compensation grade selections to satisfy the various liquid crystal temperature grades. The grading can be selected by software control. Defaulted temperature coefficient (TC) value is $-0.1\%/^{\circ}\text{C}$.

7.9 288 Bit Latch

A register carries the display signal information. In 128 X 160 display-mode, data will be fed to the HV-buffer Cell and level-shifted to the required level.

7.10 Level selector

Level Selector is a control of the display synchronization. Display voltage can be separated into two sets and used with different cycles. Synchronization is important since it selects the required LCD voltage level to the HV Buffer Cell, which in turn outputs the COM or SEG LCD waveform.

7.11 HV Buffer Cell (Level Shifter)

HV Buffer Cell works as a level shifter which translated the low voltage output signal to the required driving voltage. The output is shifted out with an internal FRM clock, which comes from the Display Timing Generator. The voltage levels are given by the level selector, which is synchronized with the internal M signal.

For a panel with N rows and M columns, the optimal LCD driving voltage are given as:

$$V_{L7} - V_{L4} = V_{L4} - V_{SS} = \sqrt{\frac{N}{4}} \times \sqrt{\frac{\sqrt{N}}{2(\sqrt{N}-1)}} \times V_{th}$$
$$V_{L6} - V_{L4} = V_{L4} - V_{L2} = \frac{4 \times (V_{L7} - V_{L4})}{\sqrt{N}}$$

And

$$V_{L5} - V_{L4} = V_{L4} - V_{L3} = \frac{V_{L6} - V_{L4}}{2}$$

where:

V_{th} is the threshold voltage of the LCD panel

V_{L7} is the maximum (Row) driving level with reference to V_{SS}
(The peak-to-peak Row driving voltage is given by $V_{L7} - V_{SS}$)

V_{L4} is the middle of all driving levels

V_{L6} , V_{L5} , V_{L3} and V_{L2} are the other Column driving levels
(The peak-to-peak Column driving voltage is given by $V_{L6} - V_{SS}$)

Relationship between the levels:

$$V_{L7} > V_{L6} > V_{L5} > V_{L4} > V_{L3} > V_{L2} > V_{SS}$$

and

$$V_{CC} > V_{L4} + 2V$$

7.12 Default Setting after Reset

When $\overline{\text{RES}}$ input is low, the chip is initialized to the following:

Register	Default Value	Descriptions
Page address	0	
Column address	0	
Display ON/OFF	0	Display OFF
Display Start Line	0	GDDRAM page 0,D0
Display Offset	0	COM0 is mapped to ROW0
Mux Ratio	A0H	160 Mux
Normal/Reverse Display	0	Normal Display
N-line Inversion	0	No N-line Inversion
Entire Display	0	Entire Display is OFF
Power Control	0,0,0	Booster, regulator & divider are both disabled
DC-DC booster	0	3X booster is selected
Internal Resistor Ratio	0	Gain = 3.2 (IR0)
Contrast	20H	Middle
LCD Bias Ratio	6	Optimized for 160 Mux
Scan direction of COM	0	Normal Scan direction
Segment Re-map	0	Segment re-map is disabled
Internal oscillator	0	Internal oscillator is OFF
Power save mode	0	Power save mode is OFF
Data display length	0	
FRC, PWM Mode	0	4FRC, 9PWM
White Palette	(0, 0, 0, 0)	
Light Gray Palette	(0, 0, 0, 0)	
Dark Gray Palette	(9, 9, 9, 9)	
Black Palette	(9, 9, 9, 9)	
Test mode	0	Test mode is OFF
Temperature coefficient	2	TC2 (-0.1%/°C)
Upper window corner	0,0	
Lower window corner	127,159	

When RESET command is issued, the following parameters are initialized only:

Register	Default Value	Descriptions
Page address	0	
Column address	0	
Display Start Line	0	GDDRAM page 0,D0
Internal Resistor Ratio	0	Gain = 3.2 (IR0)
Contrast	20H	
Data display length	0	
FRC, PWM Mode	0	4FRC, 9PWM
White Palette	(0, 0, 0, 0)	
Light Gray Palette	(0, 0, 0, 0)	
Dark Gray Palette	(9, 9, 9, 9)	
Black Palette	(9, 9, 9, 9)	

		Common Output Pins											
		1		2		3		4		5			
Example		160		160		160		146		146			
Multiplex Ratio		00h		14h		14h		05h		05h			
Display Start Line		(0,0)		(0,0)		(0,6)		(0,6)		(0,6)			
Upper Window Corner		(127,159)		(127,159)		(127,139)		(127,139)		(127,139)			
Lower Window Corner		0		0		0		0		0			
Display Offset		0		5		0		5		0			

Column Address	Seq Normal	Seq Remapped	00h	01h	02h	7Dh	7Eh	7Fh	Normal	Remapped	Normal	Remapped	Normal	Remapped	Normal	Remapped	Normal	Remapped
Segment Colour Pins	0	1	2	125	126	127	159	158	157	156	155	154	153	152	151	150	149
00h										0	159	156	153	0	159	0	159	5	154
01h	D0 (LSB)								1	158	157	154	1	158	1	158	6	153
02h	D1								2	157	156	153	2	157	2	157	7	152
03h	D2								3	156	155	152	3	156	3	156	8	151
04h	D3								4	155	154	151	4	155	4	155	9	150
05h	D4								5	154	153	150	5	154	5	154	10	149
06h	D5								6	153	152	149	6	153	6	153
07h	D6								7	152	151	148	7	152	7	152
08h	D7 (MSB)								8	151	150	147	8	151	8	151
09h	D0 (LSB)								9	150	149	146	9	150	9	150
0Ah	D1								10	149	148	145	10	149	10	149	11	148
0Bh	D2								11	148	147	144	11	148	11	148	12	147
0Ch	D3								12	147	146	143	12	147	12	147	13	146
0Dh	D4								13	146	145	142	13	146	13	146	14	145
0Eh	D5								14	145	144	141	14	145	14	145	15	144
0Fh	D6								15	144	143	140	15	144	15	144	16	143
10h	D7 (MSB)								16	143	142	139	16	143	16	143	17	142
11h	D0 (LSB)								17	142	141	138	17	142	17	142	18	141
12h	D1								18	141	140	137	18	141	18	141	19	140
13h	D2								19	140	139	136	19	140	19	140	20	139
14h	D3								20	139	138	135	20	139	20	139	21	138
15h	D4								21	138	137	134	21	138	21	138	22	137
16h	D5								22	137	136	133	22	137	22	137	23	136
17h	D6								23	136	135	132	23	136	23	136	24	135
18h	D7 (MSB)								24	135	134	131	24	135	24	135	25	134
19h	D0 (LSB)								25	134	133	130	25	134	25	134	26	133
1Ah	D1								26	133	132	129	26	133	26	133	27	132
1Bh	D2								27	132	131	128	27	132	27	132	28	131
1Ch	D3								28	131	130	127	28	131	28	131	29	130
1Dh	D4								29	130	129	126	29	130	29	130	30	129
1Eh	D5								30	129	128	125	30	129	30	129	31	128
1Fh	D6								31	128	127	124	31	128	31	128
.....
80h									128	31	108	51	108	51	123	36	127	32
81h	D0 (LSB)								129	30	109	50	109	50	124	35	128	31
82h	D1								130	29	110	49	110	49	125	34	129	30
83h	D2								131	28	111	48	111	48	126	33	130	29
84h	D3								132	27	112	47	112	47	127	32	131	28
85h	D4								133	26	113	46	113	46	128	31	132	27
86h	D5								134	25	114	45	114	45	129	30	133	26
87h	D6								135	24	115	44	115	44	130	29	134	25
88h	D7 (MSB)								136	23	116	43	116	43	131	28	135	24
89h	D0 (LSB)								137	22	117	42	117	42	132	27	136	23
8Ah	D1								138	21	118	41	118	41	133	26	137	22
8Bh	D2								139	20	119	40	119	40	134	25	138	21
8Ch	D3								140	19	120	39	120	39	135	24	139	20
8Dh	D4								141	18	121	38	121	38	136	23	140	19
8Eh	D5								142	17	122	37	122	37	137	22	141	18
8Fh	D6								143	16	123	36	123	36	138	21	142	17
90h	D7 (MSB)								144	15	124	35	124	35	139	20	143	16
91h	D0 (LSB)								145	14	125	34	125	34	140	19	144	15
92h	D1								146	13	126	33	126	33	141	18	145	14
93h	D2								147	12	127	32	127	32	142	17	146	13
94h	D3								148	11	128	31	128	31	143	16	147	12
95h	D4								149	10	129	30	129	30	144	15	148	11
96h	D5								150	9	130	29	130	29	145	14	149	10
97h	D6								151	8	131	28	131	28	146	13	150	9
98h	D7 (MSB)								152	7	132	27	132	27	147	12	151	8
99h	D0 (LSB)								153	6	133	26	133	26	148	11	152	7
9Ah	D1								154	5	134	25	134	25	149	10	153	6
9Bh	D2								155	4	135	24	135	24	150	9	154	5
9Ch	D3								156	3	136	23	136	23	151	8	155	4
9Dh	D4								157	2	137	22	137	22	152	7	156	3
9Eh	D5								158	1	138	21	138	21	153	6	157	2
9Fh	D6								159	0	139	20	139	20	154	5	158	1
A0h	D7 (MSB)				
A1h	D0 (LSB)								-	-	140	19	120	39	135	24	140	19
A2h	D1								-	-	141	18	121	38	136	23	141	18
A3h	D2								-	-	142	17	122	37	137	22	142	17
A4h	D3								-	-	143	16	123	36	138	21	143	16
A5h	D4								-	-	144	15	124	35	139	20	144	15
A6h	D5								-	-	145	14	125	34	140	19	145	14
A7h	D6								-	-	146	13	126	33	141	18	146	13
A8h	D7 (MSB)								-	-	147	12	127	32	142	17	147	12
A9h	D0 (LSB)								-	-	148	11	128	31	143	16	148	11
AAh	D1								-	-	149	10	129	30	144	15	149	10
ABh	D2								-	-	150	9	130	29				

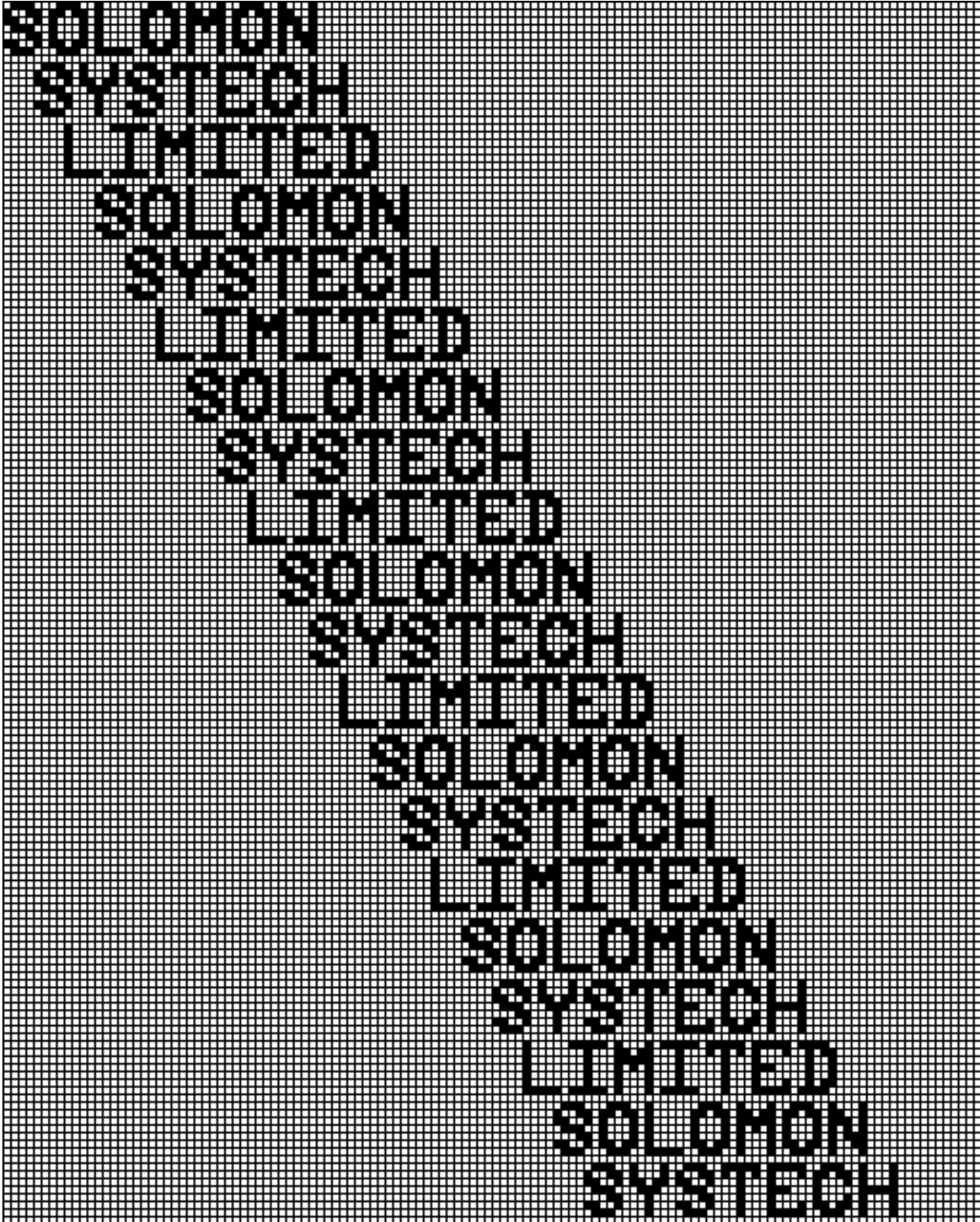

Example 1 – Display Start Line = 0, Multiplex Ratio = 160, Display Offset = 0.

Upper Window Row = (0,0), Lower Window Row = (127,159)

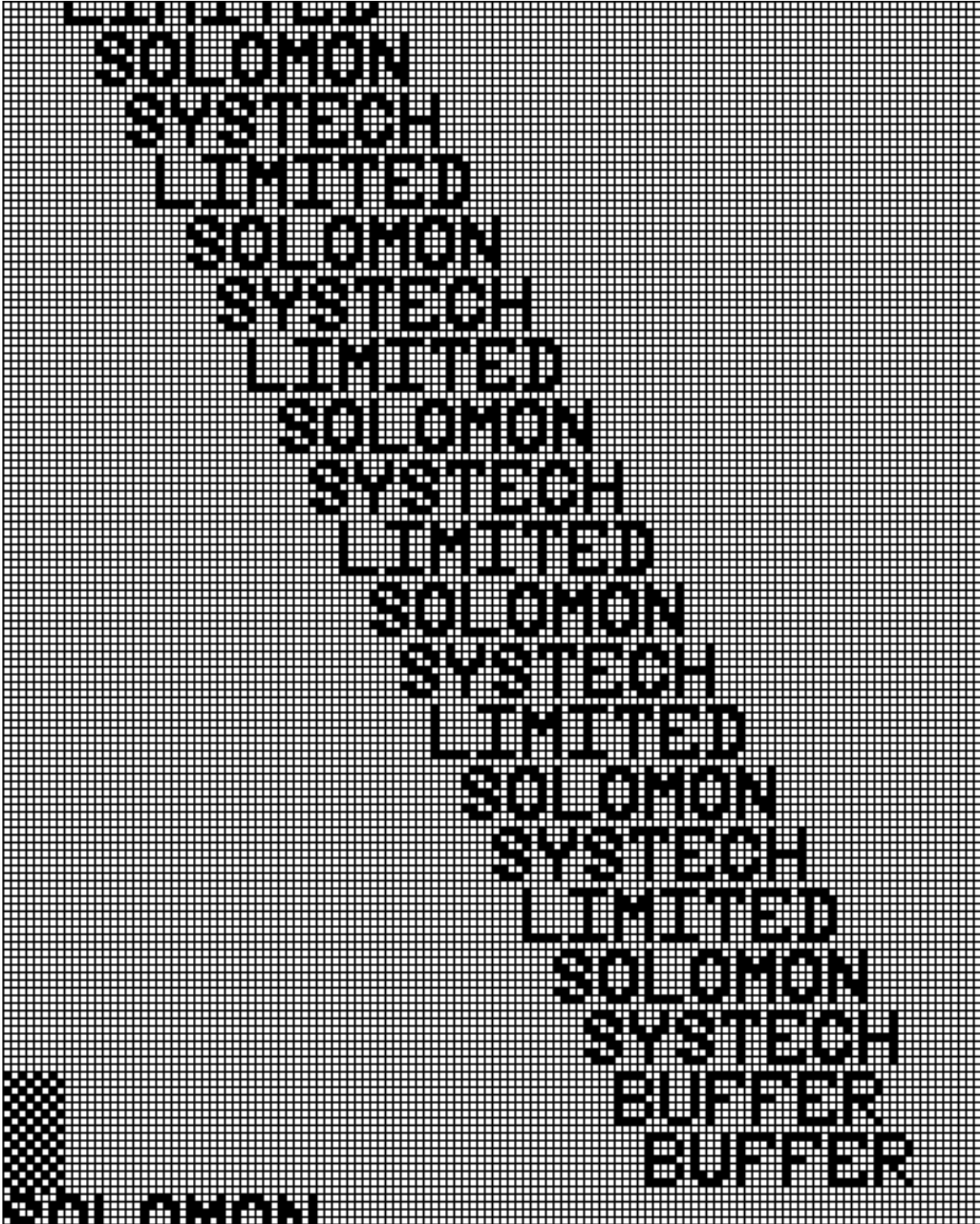

Example 2 – Display Start Line = 14h, Multiplex Ratio = 160, Display Offset = 0.

Upper Window Row = (0,0), Lower Window Row = (127,159)

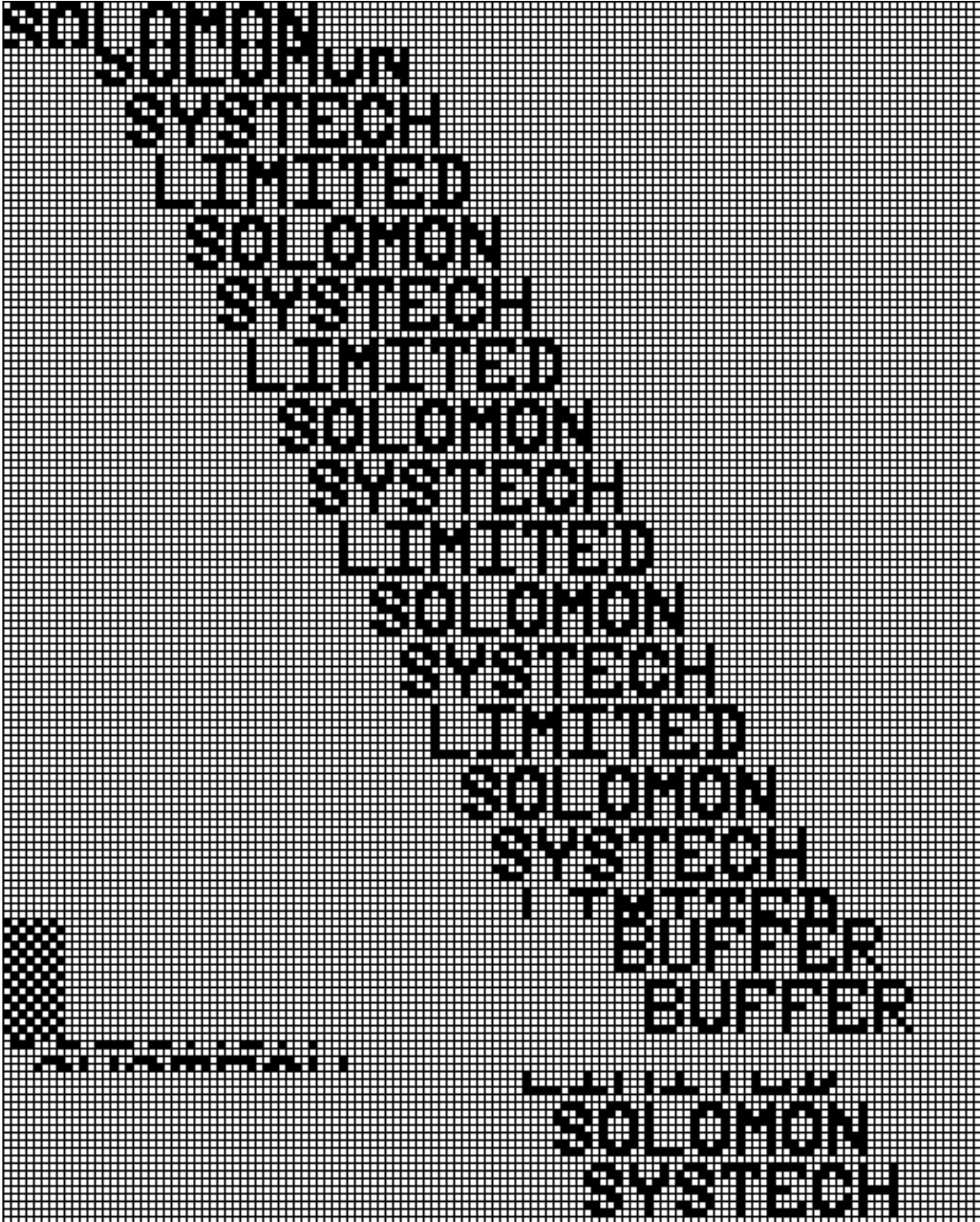

Example 3 – Display Start Line = 14h, Multiplex Ratio = 160, Display Offset = 0.

Upper Window Row = (0,6), Lower Window Row = (127,139)

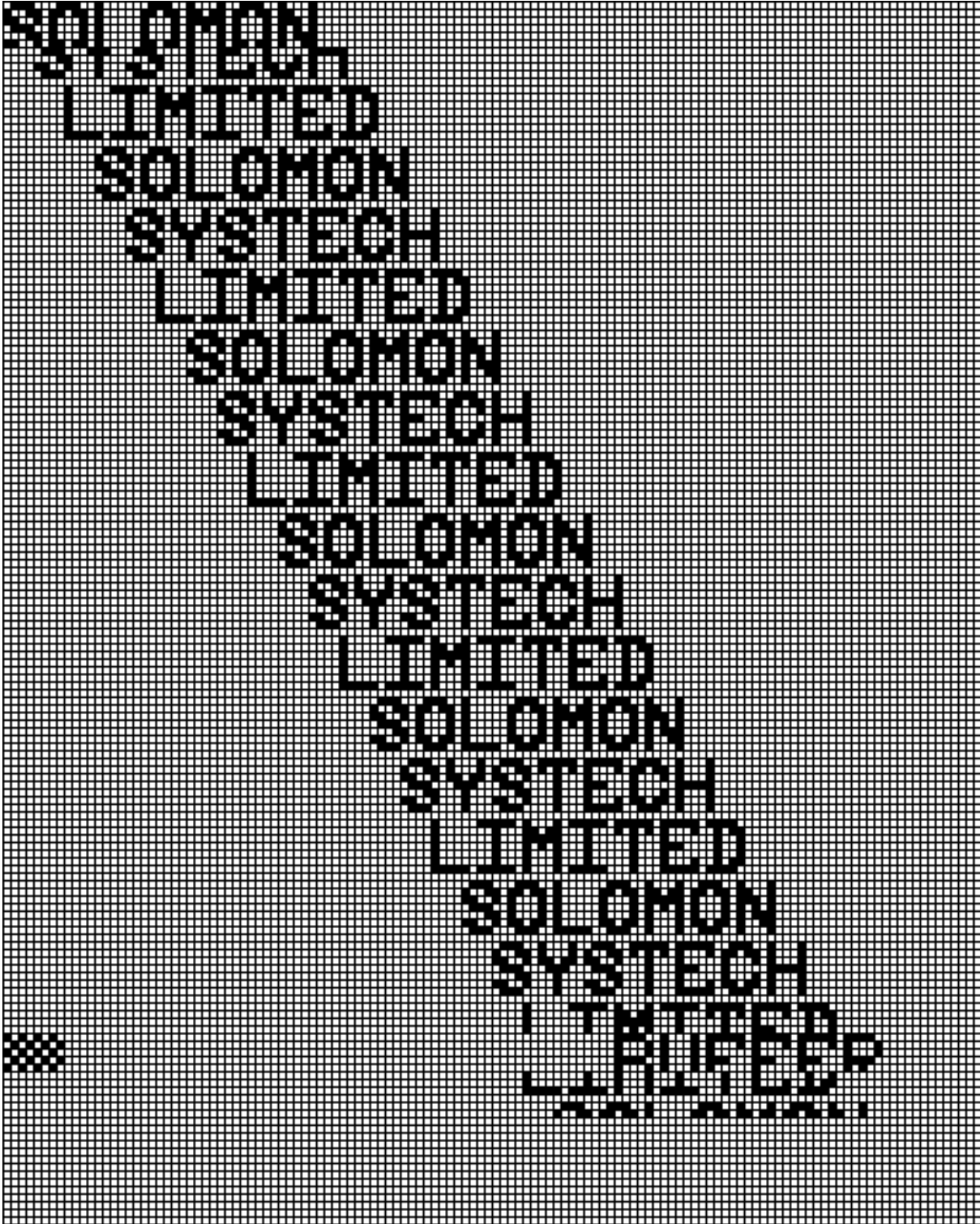

Example 4 – Display Start Line = 5, Multiplex Ratio = 146, Display Offset = 0.

Upper Window Row = (0,6), Lower Window Row = (127,139)

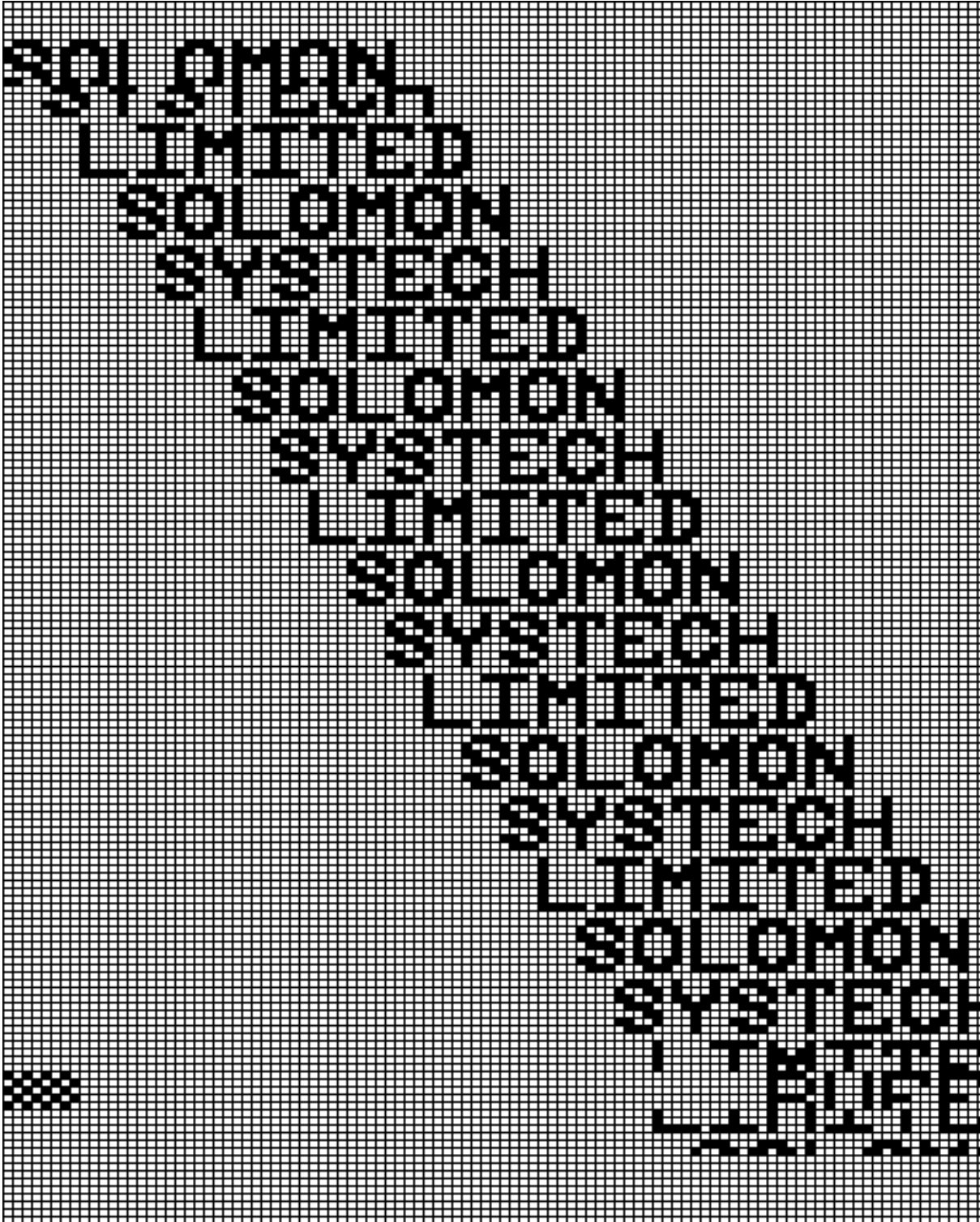

Example 5 – Display Start Line = 5, Multiplex Ratio = 146, Display Offset = 5.

Upper Window Row = (0,6), Lower Window Row = (127,139)

7.13 Command Table

Table 5 - COMMAND TABLE

Hex	Bit Pattern	Command	Description
00~0F	0000 C ₃ C ₂ C ₁ C ₀	Set Lower Column Address	Set the lower nibble of the column address pointer for RAM access. The pointer is reset to 0 after reset.
10~17	0001 0C ₆ C ₅ C ₄	Set Upper Column Address	Set the upper nibble of the column address pointer for RAM access. The pointer is reset to 0 after reset.
18~19	0001 100M ₀	Set Master/Slave Mode	M ₀ =0: Master operation mode (POR) M ₀ =1: Slave operation mode
1A~1F		Reserved	Reserved
20~27	0010 0R ₂ R ₁ R ₀	Set Internal Regulator Resistor Ratio	The internal regulator gain increases as R ₂ R ₁ R ₀ is increased from 000b to 111b. The factor, 1+R ₂ /R ₁ , is given by: R ₂ R ₁ R ₀ = 000: 3.2 (POR) R ₂ R ₁ R ₀ = 001: 3.9 R ₂ R ₁ R ₀ = 010: 4.6 R ₂ R ₁ R ₀ = 011: 5.3 R ₂ R ₁ R ₀ = 100: 6.0 R ₂ R ₁ R ₀ = 101: 6.7 R ₂ R ₁ R ₀ = 110: 7.4 R ₂ R ₁ R ₀ = 111: 8.1 (Refer to section 8.4)
28~2F	0010 1VCVRVF	Set Power Control Register	VC=0: turn OFF the internal voltage booster (POR) VC=1: turn ON the internal voltage booster VR=0: turn OFF the internal regulator (POR) VR=1: turn ON the internal regulator VF=0: turn OFF the output op-amp buffer (POR) VF=1: turn ON the output op-amp buffer
30~3F		Reserved	Reserved
40~43	0100 00XX L ₇ L ₆ L ₅ L ₄ L ₃ L ₂ L ₁ L ₀	Set Display Start Line	The second command specifies the row address pointer of the RAM data to be displayed in first row of window. The value must be within 0 to window row number + 15. See the RAM Mapping Table for examples.
44~47	0100 01XX C ₇ C ₆ C ₅ C ₄ C ₃ C ₂ C ₁ C ₀	Set Display Offset	The second command specifies the mapping of first display line (COM0) to one of ROW0~159. COM0 is mapped to ROW0 after reset.
48~4B	0100 10XX D ₇ D ₆ D ₅ D ₄ D ₃ D ₂ D ₁ D ₀	Set Multiplex Ratio	The second command specifies the number of lines to be displayed. Duties 1/16~1/160 could be selected. The duty ratio is set to 1/160 after reset. See the Ram Mapping Table for examples.
4C~4F	0100 11XX XXN ₅ N ₄ N ₃ N ₂ N ₁ N ₀	Set N-line Inversion	The second command sets the n-line inversion register from 1 to 63 lines to reduce display crosstalk. Register values from 00001b to 11111b are mapped to 1 line to 63 lines respectively. Value 00000b disables the N-line inversion.
50~57	0101 0B ₂ B ₁ B ₀	Set LCD Bias	Sets the LCD bias corresponding to different mux number. B ₂ B ₁ B ₀ : 000: 32mux 010: 96mux 100: 128mux 110: 160mux (POR)
58~5F		Reserved	Reserved

60	0110 0000 0A ₆ A ₅ A ₄ A ₃ A ₂ A ₁ A ₀	Set Upper Window Corner a _x	The second command sets the first column of the scroll window. It is set to 0 after POR.																	
61	0110 0001 A ₇ A ₆ A ₅ A ₄ A ₃ A ₂ A ₁ A ₀	Set Upper Window Corner a _y	The second command sets the first row of the scroll window. It is set to 0 after POR.																	
62	0110 0010 0B ₆ B ₅ B ₄ B ₃ B ₂ B ₁ B ₀	Set Lower Window Corner b _x	The second command sets the last column of the scroll window. It is set to 0 after POR.																	
63	0110 0011 B ₇ B ₆ B ₅ B ₄ B ₃ B ₂ B ₁ B ₀	Set Lower Window Corner b _y	The second command sets the last row of the scroll window. It is set to 0 after POR.																	
64~67	0110 01B ₁ B ₀	Set DC-DC Converter Factor	Set the DC-DC multiplying factor from 3X to 5X according to B ₁ B ₀ . B ₁ B ₀ : 00: 3X (POR) 01: 4X 10: 5X 11: 5X																	
68~80		Reserved	Reserved																	
81	1000 0001 XXC ₅ C ₄ C ₃ C ₂ C ₁ C ₀	Set Contrast Control Register	The second command sets one of the 64 contrast levels. The darkness increase as the contrast level increase.																	
82~87		Reserved	Reserved																	
88	1000 1000 WB ₃ WB ₂ WB ₁ WB ₀ WA ₃ WA ₂ WA ₁ WA ₀	Set White Mode, Frame 2 nd & 1 st	Grey palette programming. These are two-byte commands used to specify the contrast levels for the gray scale, 4 levels available. The relationship between gray mode and data in RAM is as follow: <table border="1" style="margin-left: auto; margin-right: auto;"> <thead> <tr> <th colspan="2">Memory Content</th> <th rowspan="2">Gray Mode</th> </tr> <tr> <th>1st Byte</th> <th>2nd Byte</th> </tr> </thead> <tbody> <tr> <td>0</td> <td>0</td> <td>White</td> </tr> <tr> <td>0</td> <td>1</td> <td>Light gray</td> </tr> <tr> <td>1</td> <td>0</td> <td>Dark gray</td> </tr> <tr> <td>1</td> <td>1</td> <td>Black</td> </tr> </tbody> </table>	Memory Content		Gray Mode	1 st Byte	2 nd Byte	0	0	White	0	1	Light gray	1	0	Dark gray	1	1	Black
Memory Content		Gray Mode																		
1 st Byte	2 nd Byte																			
0	0	White																		
0	1	Light gray																		
1	0	Dark gray																		
1	1	Black																		
89	1000 1001 WD ₃ WD ₂ WD ₁ WD ₀ WC ₃ WC ₂ WC ₁ WC ₀	Set White Mode, Frame 4 th & 3 rd																		
8A	1000 1010 LB ₃ LB ₂ LB ₁ LB ₀ LA ₃ LA ₂ LA ₁ LA ₀	Set Light Gray Mode, Frame 2 nd & 1 st																		
8B	1000 1011 LD ₃ LD ₂ LD ₁ LD ₀ LC ₃ LC ₂ LC ₁ LC ₀	Set Light Gray Mode, Frame 4 th & 3 rd																		
8C	1000 1100 DB ₃ DB ₂ DB ₁ DB ₀ DA ₃ DA ₂ DA ₁ DA ₀	Set Dark Gray Mode, Frame 2 nd & 1 st																		
8D	1000 1101 DD ₃ DD ₂ DD ₁ DD ₀ DC ₃ DC ₂ DC ₁ DC ₀	Set Dark Gray Mode, Frame 4 th & 3 rd																		
8E	1000 1110 BB ₃ BB ₂ BB ₁ BB ₀ BA ₃ BA ₂ BA ₁ BA ₀	Set Black Mode, Frame 2 nd & 1 st																		
8F	1000 1111 BD ₃ BD ₂ BD ₁ BD ₀ BC ₃ BC ₂ BC ₁ BC ₀	Set Black Mode, Frame 4 th & 3 rd																		
90~97	1001 0 FRC PWM1 PWM0	Set PWM and FRC	Set PWM and FRC for gray-scale operation. FRC = 0: 4-frames (POR) FRC = 1: 3-frames PWM = 00: 9-levels (POR) PWM = 01: 9-levels PWM = 10: 12-levels PWM = 11: 15-levels																	
98~9F		Reserved	Reserved																	
A0~A1	1010 000S ₀	Set Segment Re-map	S ₀ =0: column address 00H is mapped to SEG0 (POR) S ₀ =1: column address 7FH is mapped to SEG0																	
A2~A3		Reserved	Reserved																	
A4~A5	1010 010E ₀	Set Entire Display On/Off	E ₀ =0: Normal display (display according to RAM contents, POR) E ₀ =1: All pixels are ON regardless of the RAM contents																	

A6~A7	1010 011R ₀	Set Normal/Reverse Display	R ₀ =0: Normal display (display according to RAM contents, POR) R ₀ =1: Reverse display (ON and OFF pixels are inverted)
A8		Reversed	Reversed
A9	1010 1001	Set Power Save Mode	Oscillator: OFF LCD Power Supply: OFF COM/SEG Outputs: V _{SS}
AA		Reserved	Reserved
AB	1010 1011	Start Internal Oscillator	This command starts the internal oscillator. Note that the oscillator is OFF after reset, until this command is issued.
AE~AF	1010 111D ₀	Set Display On/Off	D ₀ =0: Display OFF (POR) D ₀ =1: Display ON
B0~BF	1011 XXXX 000P ₄ P ₃ P ₂ P ₁ P ₀	Set Page Address	Selects the page of display RAM to be addressed. The second command specifies the page address pointer (0~21) of the RAM data to be written. The values other than (0~21) are reversed.
C0~CF	1100 S ₀ XXX	Set COM Output Scan Direction	S ₀ =0: Normal mode (POR) S ₀ =1: Remapped mode (COM0 to COM[N-1] becomes COM159 to COM[159-N+1])
D0~E0		Reserved	Reserved
E1	1110 0001	Exit Power-save Mode	Return the driver/controller from the sleep mode.
E2	1110 0010	Software Reset	Initialize some internal registers.
E3		Reserved	Reserved
E4	1110 0100	Exit N-line Inversion	Release the driver/controller from N-line inversion mode.
E5		Reserved	Reserved
E6~E7	1110 011 S ₀	Enable Scroll Buffer RAM	This command enable/disable the use of RAM page 20 and 21 during scrolling. S ₀ =0: Enable Scroll Buffer RAM (POR) S ₀ =1: Disable Scroll Buffer RAM
E8	1110 1000 D ₇ D ₆ D ₅ D ₄ D ₃ D ₂ D ₁ D ₀	Set Display Data Length	This command is used in 3-line SPI mode (PS0=PS1=L). The next command specifies the number of bytes (1 to 256 bytes) of display data to be written after this composite command. D ₇ ~D ₀ =00; 1byte D ₇ ~D ₀ =FF; 256bytes
E9	0011 1001 XXXX XT ₂ T ₁ T ₀	Set TC value	This command selects the Temperature Coefficient setting for fitting different LCD panel characteristics. T ₂ T ₁ T ₀ : 000: -0.05%/°C (TC0) 001: Reserved 010: -0.10%/°C (TC2, POR) 011: Reserved 100: -0.15%/°C (TC4) 101: Reserved 110: -0.21%/°C (TC6) 111: Reserved
EA~EF		Reserved	Reserved
F0~FF	1111 XXXX	Extended Features	Test mode commands and Extended features

7.14 Read Status Byte

An 8 bits status byte will be placed to the data bus if a read operation is performed if $\overline{D/C}$ is low. The status byte is defined as follow.

Table 6 - Read Status Byte

D7	D6	D5	D4	D3	D2	D1	D0	Command	Comment
BUSY	ON	RES	0	1	0	1	1	Read Status	BUSY=0: Chip is idle BUSY=1: Chip is executing instruction ON=0: Display is OFF ON=1: Display is ON RES=0: Chip is idle RES=1: Chip is executing reset

7.15 Data Read / Write

To read data from the GDDRAM, input High to $\overline{R/W}(\overline{WR})$ pin and $\overline{D/C}$ pin for 6800-series parallel mode. Low to $\overline{E}(\overline{RD})$ pin and High to $\overline{D/C}$ pin for 8080-series parallel mode. A complete data read cycle must issue two clocks to read both First Byte and Second Byte from GDDRAM. No data read is provided for serial mode. In normal mode, GDDRAM column address pointer will be increased by one automatically after each complete data read cycle. Also, a dummy read is required before the first data is read. See Figure 3 in Functional Description.

To write data to the GDDRAM, input Low to $\overline{R/W}(\overline{WR})$ pin and High to $\overline{D/C}$ pin for 6800-series parallel mode. High to $\overline{E}(\overline{RD})$ pin and Low to $\overline{D/C}$ pin for 8080-series parallel mode. A complete data write cycle must issue two clocks to write both First Byte and Second Byte to GDDRAM. For serial interface, it will always be in write mode. GDDRAM column address pointer will be increased by one automatically after each complete data write cycle. The column address will be reset to 0 in next data read/write operation is executed when it is 127.

Table 7 - Address Increment Table (Automatic)

$\overline{D/C}$	$\overline{R/W}(\overline{WR})$	Comment	Address Increment
0	0	Write Command	No
0	1	Read Status	No
1	0	Write Data	Yes
1	1	Read Data	Yes

Address Increment is done automatically after two data read/write. The column address pointer of GDDRAM is also affected. It will be reset to 0 after 127. It should be noted that the page address will NOT be changed when this wrap round happens.

Table 8 - Commands Required for $\overline{R/W}(\overline{WR})$ Actions on RAM

$\overline{R/W}(\overline{WR})$ Actions on RAMs	Commands Required	
Read/write Data from/to GDDRAM	Set GDDRAM Page Address	(1011XXXX)* (X ₇ X ₆ X ₅ X ₄ X ₃ X ₂ X ₁ X ₀)*
	Set GDDRAM Column Address	(00010X ₂ X ₁ X ₀)* (0000X ₃ X ₂ X ₁ X ₀)*
	Read/Write Data	(X ₇ X ₆ X ₅ X ₄ X ₃ X ₂ X ₁ X ₀)

* No need to resend the command again if it is set previously.

The read / write action to the Display Data RAM does not depend on the display mode. This means the user can change the RAM content whether the target RAM content is being displayed or not.

8 COMMAND DESCRIPTIONS

8.1 Set Lower Column Address [00~0F]

This command specifies the lower nibble of the 7-bit column address of the display data RAM. The column address will be incremented by each data access after it is pre-set by the MCU and returning to 0 once overflow (>127).

8.2 Set Higher Column Address [10~17]

This command specifies the higher nibble of the 7-bit column address of the display data RAM. The column address will be incremented by each data access after it is pre-set by the MCU and returning to 0 once overflow (>127).

8.3 Set Master/Slave Mode [18~19]

This command is used in Cascade function, programming the driver into slave mode. The Osc clock and M clock (frame) will be received externally to synchronize the COM/SEG waveform.

8.4 Set Internal Regulator Resistors Ratio [20~27]

This command is to enable any one of the eight internal resistor (IRS) settings for different regulator gains when using internal regulator resistor network. The Contrast Control Voltage Range curves is referred to the following formula:

$$V_{out} = \left(1 + \frac{R_2}{R_1}\right) * V_{con}$$

$$V_{con} = \left(1 - \frac{63 - \alpha}{210}\right) * V_{ref} \quad , \text{where } V_{ref} = 2.1V$$

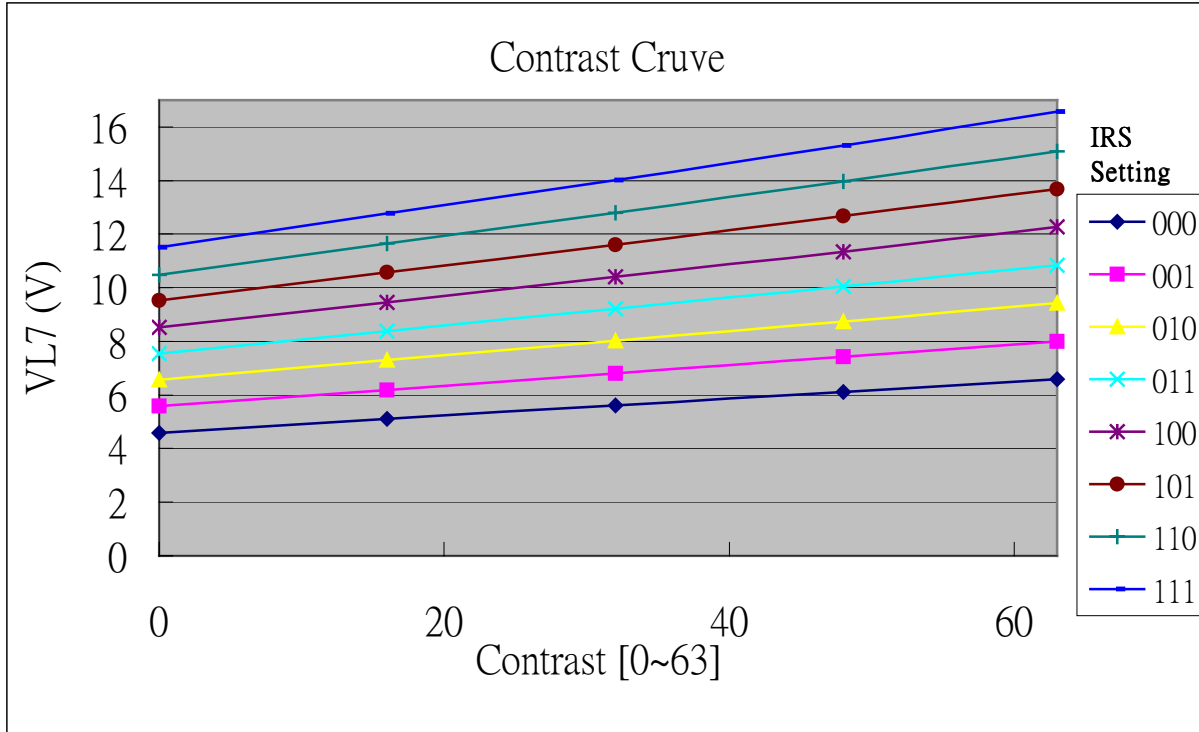

Figure 6 - Contrast Control Voltage Range Curve (TC=-0.1%/°C; V_{DD}=2.7V; V_{CI}=2.7V)

8.5 Set Power Control Register [28~2F]

This command turns on/off the various power circuits associated with the chip. All the function blocks can be turn-on independently, but a 10ms-time must be wait between turn ON the Regulator and Divider.

8.6 Set Display Start Line [40~43]

The second byte sent specifies which row of the RAM is to be displayed in the first row of window defined by Set Upper/Lower Window Corner commands. Vertical window scrolling is achieved by setting this value from 0 up to window row number + 15. The content outside the Upper and Lower Window Row will not be affected. Refer to Page 21, example 5 for more information.

8.7 Set Display Offset [44~47]

The second byte sent specifies the mapping of display start line (COM0 if display start line register equals to 0) to one of ROW0-159. COM0 is mapped to ROW0 after reset.

8.8 Set Multiplex Ratio [48~4B]

This command switches default 160 multiplex modes to any multiplex from 16 to 160. The chip pads ROW0-ROW159 will be switched to corresponding COM signal output. Examples were given in the RAM map table. If the input value is not a number of 160, 128, 64 or 32, the higher number of mux will be applied to the COMx pins and the RAM content of the additional lines will be masked out from the display. Thus the actual display effect will be equal to the input value. Suitable bias ration must be set by using Set LCD Bias command after this command is issued.

8.9 Set N-line Inversion [4C~4F]

Number of line inversion is set by this command for reducing crosstalk noise. 1 to 63-line inversion operations could be selected. At POR, this operation is disabled.

8.10 Set LCD Bias [50~57]

This command selects a suitable bias ratio required for driving the particular LCD panel in use. The POR default for SSD1854 is set to the optimization for 160 mux display mode.

8.11 Set Upper Window Corner (ax, ay) [60~61]

These commands are used to define the upper left corner of the window for vertical scrolling. After POR, these registers are set to (0, 0). The actual window position will be offset by the Set Display Offset command.

8.12 Set Lower Window Corner (bx, by) [62~63]

These commands are used to define the lower right corner of the window for vertical scrolling. After POR, these registers are set to (127, 159). These registers must be smaller than the multiplex ratio as defined by Set Multiplex Ratio.

8.13 Set DC-DC Converter Factor [64~67]

Internal DC-DC converter factor is set by this command. For SSD1854, 3X to 5X multiplying factors could be selected.

8.14 Set Contrast Control Register [81]

This command adjusts the contrast of the LCD panel by changing V_{L7} of the LCD drive voltage provided by the On-Chip power circuits. V_{L7} is set with 64 steps (6-bit) contrast control register. It is a compound commands:

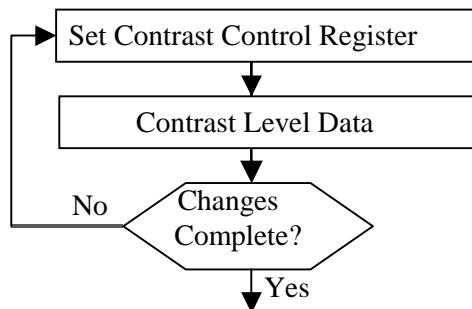

Figure 7 - Contrast Control Flow Set Segment Re-map

8.15 Set Gray Scale Mode (White/Light Gray/Dark Gray/Black mode) [88~8F]

Four gray scale modes – White, Light gray, Dark gray and Black – can be set. Each consists of four registers namely A, B, C and D which correspond to four frames in FRC. Each of the 4-bits in register A, B, C and D are used to define the width of PWM.

For 4 FRC,

Memory Content		Gray Mode	FRAME			
1 st Byte	2 nd Byte		1 st	2 nd	3 rd	4 th
0	0	White	WA	WB	WC	WD
0	1	Light Gray	LA	LB	LC	LD
1	0	Dark Gray	DA	DB	DC	DD
1	1	Black	BA	BB	BC	BD

For 3 FRC,

Memory Content		Gray Mode	FRAME			
1 st Byte	2 nd Byte		1 st	2 nd	3 rd	4 th (No use)
0	0	White	WA	WB	WC	WD (XX)
0	1	Light Gray	LA	LB	LC	LD (XX)
1	0	Dark Gray	DA	DB	DC	DC (XX)
1	1	Black	BA	BB	BC	BC (XX)

8.16 Set Segment Re-map [A0~A1]

This commands changes the mapping between the display data column address and segment driver. It allows flexibility in layout during LCD module assembly. Refer to Figure 5.

8.17 Set Entire Display On/Off [A4~A5]

This command forces the entire display to be illuminated regardless of the contents of the GDDRAM. This command has priority than the “Set Normal/Reverse Display” but lower priority than the “Set Display On/Off” command.

8.18 Set Normal/Reverse Display [A6~A7]

This command sets the display to be either normal/reverse. In reverse display, a RAM data of ‘0’ indicates an “ON” pixel while in normal display; a RAM data of ‘0’ indicates an “OFF” pixel. This command has lower priority than both “Set Display On/Off” and “Set Entire Display On/Off”.

8.19 Set Power Save Mode [A9]

This command is to force the chip to enter Sleep Mode. The internal oscillator and LCD power supply will be turn off when enter to such mode.

8.20 Start Internal Oscillator [AB]

After POR, the internal oscillator is OFF. It should be turned ON by sending this command to the chip.

8.21 Set Display On/Off [AE~AF]

This command is used to turn the display on or off, by the value of the LSB. It has the highest priority over other commands regarding the display effect.

8.22 Set Page Address [B0~BF]

This command positions the page address of 0 to 21 possible positions in GDDRAM. Refer to Figure 5. During 16-bits write operation, the last bit of the page address is ignored, D0-D7 always writes to even page and D8-D15 always writes to odd address.

8.23 Set COM Output Scan Direction [C0~CF]

This command sets the scan direction of the COM output allowing layout flexibility in LCD module assembly.

8.24 Exit Power Save Mode [E1]

This command releases the chip from Sleep Mode and return to normal operation.

8.25 Software Reset [E2]

This command causes some of the internal status of the chip to be initialized:

Register	Default Value	Descriptions
Page address	0	
Column address	0	
Display Start Line	0	GDDRAM page 0,D0
Internal Resistor Ratio	0	Gain = 3.2 (IRS0)
Contrast	20H	
Data display length	0	
FRC, PWM Mode	0	4FRC, 9PWM
White Palette	(0, 0, 0, 0)	
Light Gray Palette	(0, 0, 0, 0)	
Dark Gray Palette	(9, 9, 9, 9)	
Black Palette	(9, 9, 9, 9)	

8.26 Exit N-line Inversion [E4]

This command releases the chip from N-line inversion mode. The driving waveform will be inverted once per frame after issuing this command.

8.27 Enable Scroll Buffer RAM [E6~E7]

This command is used in enable RAM page 20 and 21 for a smooth window scrolling. When this is enabled, D0 of page 20 will appear right after the last row as defined by Set Lower Window Corner command. The next display data after D7 of page 21 is defined by Set Upper Window Corner command. When this is disabled, the data in RAM page 20 and 21 will not be displayed and the display data defined by Set Upper Window Corner command will be displayed right after the display data defined by Set Lower Window Corner command. After POR, the scroll buffer RAM is enabled.

8.28 Set Display Data Length [E8]

This two-bytes command only valid when 3-wire SPI configuration is set by H/W input (PS0=PS1=L). The second byte is used to indicate that a specified number display data byte(s) (1-256) are to be transmitted. Next byte after the display data string is handled as a command.

8.29 Set Temperature Coefficient (TC) Value [E9]

This command is to set 1 out of 4 different temperature coefficients in order to match various liquid crystal temperature grades.

8.30 Set Test Mode [F0~FF]

This command forces the driver chip into its test mode for internal testing of the chip. Under normal operation, user should NOT use this command.

9 MAXIMUM RATINGS

Table 9 - Maximum Ratings (Voltage Referenced to V_{SS} , $T_A = 25^\circ\text{C}$)

Symbol	Parameter	Value	Unit
V_{DD}	Supply Voltage	-0.3 to +4.0	V
V_{CC}		$V_{SS} - 0.3$ to $V_{SS} + 17.0$	V
V_{Cl}	Booster Supply Voltage	-0.3 to +4.0	V
V_{in}	Input Voltage	$V_{SS} - 0.3$ to $V_{DD} + 0.3$	V
I	Current Drain Per Pin Excluding V_{DD} and V_{SS}	25	mA
T_A	Operating Temperature	-20 to +85	$^\circ\text{C}$
T_{stg}	Storage Temperature Range	-65 to +150	$^\circ\text{C}$

* Maximum Ratings are those values beyond which damage to the device may occur. Functional operation should be restricted to the limits in the Electrical Characteristics tables or Pin Description section.

This device contains circuitry to protect the inputs against damage due to high static voltages or electric fields; however, it is advised that normal precautions be taken to avoid application of any voltage higher than maximum rated voltages to this high impedance circuit. For proper operation it is recommended that V_{in} and V_{out} be constrained to range $V_{SS} < \text{or} = (V_{in} \text{ or } V_{out}) < \text{or} = V_{DD}$. Reliability of operation is enhanced if unused inputs are connected to an appropriate logic voltage level (e.g. either V_{SS} or V_{DD}). Unused outputs must be open. This device may be light sensitive. Caution should be taken to avoid exposure of this device any light source during normal operation. This device is not radiation protected.

10 DC CHARACTERISTICS

Table 10 - DC Characteristics (Unless otherwise specified, Voltage Referenced to V_{SS} , $V_{DD} = 1.8$ to $3.3V$, $T_A = -20$ to $85^\circ C$)

Symbol	Parameter	Test Condition	Min	Typ	Max	Unit
V_{DD}	Logic Circuit Supply Voltage Range	(Absolute value referenced to V_{SS})	1.8	-	3.3	V
V_{CI}	Booster Voltage Supply Pin					
V_{REF}	Internal Reference Voltage ($25^\circ C$, $-0.10\%/^\circ C$)	Internal Reference Voltage Source Enabled (REF pin pulled High), V_{EXT} pin NC.	-	2.1	-	
I_{AC}	Access Mode Supply Current Drain (V_{DD} Pin)	$V_{DD} = 2.7V$, Voltage Generator On, 4X DC-DC Converter Enabled, Write accessing, $T_{cyc} = 3.3MHz$, Osc. Freq. = 120kHz, Display On.	-	450	550	μA
I_{DP1}	Display Mode Supply Current Drain (V_{DD} & V_{CI} Pins)	$V_{DD} = V_{CI} = 2.7V$, Voltage Generator On, 4X DC-DC Converter Enabled. Read/Write Halt, Osc. Freq. = 120kHz, Display On, $V_{L7} = 13.8V$.	-	550	900	μA
I_{SB}	Standby Mode Supply Current Drain	$V_{DD} = 2.7V$, LCD Driving Waveform Off, Oscillating Freq. = 120kHz, Read/Write halt.	-	90	130	μA
I_{SLEEP}	Sleep Mode Supply Current Drain (V_{DD} Pins)	$V_{DD} = 2.7V$, LCD Driving Waveform Off, Oscillator Off, Read/Write halt.	-	-	2	μA
V_{CC}	LCD Driving Voltage Generator Output (V_{CC} Pin)	Display On, Voltage Generator Enabled, DC/DC Converter Enabled, Regulator Enabled, Osc. Freq. = 120kHz,	V_{DD}	-	17.0	V
V_{OH1}	Output High Voltage (D_0 - D_{15})	$I_{out} = +100\mu A$	$0.8 * V_{DD}$	-	V_{DD}	V_{LCD}
V_{OL1}	Output Low Voltage (D_0 - D_{15})	$I_{out} = -100\mu A$	0	-	$0.2 * V_{DD}$	V
V_{L7}	Most positive LCD Driving Voltage Source (V_{L7} Pin)	Regulator and Bias Divider Enabled (V_{L7} voltage depends on Internal contrast Control)	V_{DD}	-	17.0	V
V_{L7}	Most positive LCD Driving Voltage Source (V_{L7} Pin)	Regulator and Bias Divider Disable	-	Floating	-	V
V_{IH1}	Input high voltage (\overline{RES} , $PS0$ -2, \overline{CS} , E , D/\overline{C} , R/W , D_0 - D_{15} , REF)		$0.8 * V_{DD}$	-	V_{DD}	V
V_{IL1}	Input low voltage (\overline{RES} , $PS0$ -2, \overline{CS} , E , D/\overline{C} , R/W , D_0 - D_{15} , REF)		0	-	$0.2 * V_{DD}$	V
V_{L7}	LCD Display Voltage Output (V_{L7} , V_{L6} , V_{L5} , V_{L4} , V_{L3} , V_{L2} Pins)	Regulator and Bias Divider Enabled	-	-	17	V
V_{L6}			-	-	14.5	V
V_{L5}			-	-	11.5	V
V_{L4}			-	-	8.5	V
V_{L3}			-	-	7.15	V
V_{L2}			-	-	5.8	V
V_{L7}	LCD Display Voltage Input (V_{L7} , V_{L6} , V_{L5} , V_{L4} , V_{L3} , V_{L2} Pins)	Voltage reference to V_{SS} , External Voltage Generator, Bias Diver Disabled	V_{L6}	-	17	V
V_{L6}			V_{L5}	-	V_{L7}	V
V_{L5}			V_{L4}	-	V_{L6}	V
V_{L4}			V_{L3}	-	V_{L5}	V
V_{L3}			V_{L2}	-	V_{L4}	V
V_{L2}			V_{SS}	-	V_{L3}	V

Symbol	Parameter	Test Condition	Min	Typ	Max	Unit
I _{OH}	Output High Current Source (D ₀ -D ₁₅)	Output Voltage=V _{DD} -0.4V	50	-	-	μA
I _{OL}	Output Low Current Drain (D ₀ -D ₁₅)	Output Voltage = 0.4V	-	-	-50	μA
I _{OZ}	Output Tri-state Current Source (D ₀ -D ₁₅)		-1	-	1	μA
I _{IL} / I _{IH}	Input Current (RES, PS0-2, CS, E, D/C, R/W, D ₀ -D ₁₅ , REF)		-1	-	1	μA
C _{IN}	Input Capacitance (all logic pins)		-	5	7.5	pF
ΔV _{L7}	Variation of V _{L7} Output (1.8V < V _{DD} < 3.5V)	Regulator and Bias Divider Enabled, Internal Contrast Control Enabled, Set Contrast Control Register = 32	-2	0	+2	%
TC0	Temperature Coefficient 0*	Voltage Regulator Enabled	-0.06	-0.05	-0.04	%
TC2	Temperature Coefficient 2* (POR)	Voltage Regulator Enabled	-0.11	-0.10	-0.09	%
TC4	Temperature Coefficient 4*	Voltage Regulator Enabled	-0.16	-0.15	-0.14	%
TC6	Temperature Coefficient 6*	Voltage Regulator Enabled	-0.22	-0.21	-0.20	%

* The formula for the temperature coefficient is:

$$TC(\%) = \frac{V_{REF \text{ at } 50^{\circ}C} - V_{REF \text{ at } 0^{\circ}C}}{50^{\circ}C - 0^{\circ}C} \times \frac{1}{V_{REF \text{ at } 25^{\circ}C}} \times 100\%$$

11 AC CHARACTERISTICS

Table 11 - AC Characteristics (Unless otherwise specified, Voltage Referenced to V_{SS} , V_{DD} , $V_{CI} = 2.7V$, $T_A = -20$ to $85^\circ C$)

Symbol	Parameter	Test Condition	Min	Typ	Max	Unit
ΔF_{osc}	Variation of Oscillation Frequency	Oscillator Resistor = 680K Ω	-10	-	+10	%

$$\text{Frame Frequency} = \frac{F_{osc}}{(PWM + 1) \times MUX}$$

where F_{osc} is the oscillation Frequency
 PWM is the Pulse Width Modulation level
 MUX is the multiplex ratio

Example 1:

$F_{osc} = 120\text{KHz}$; PWM = 9 level; MUX = 160

Frame Frequency = 75 Hz

Example 2:

$F_{osc} = 120\text{KHz}$; PWM = 15 level; MUX = 128

Frame Frequency = 58.6 Hz

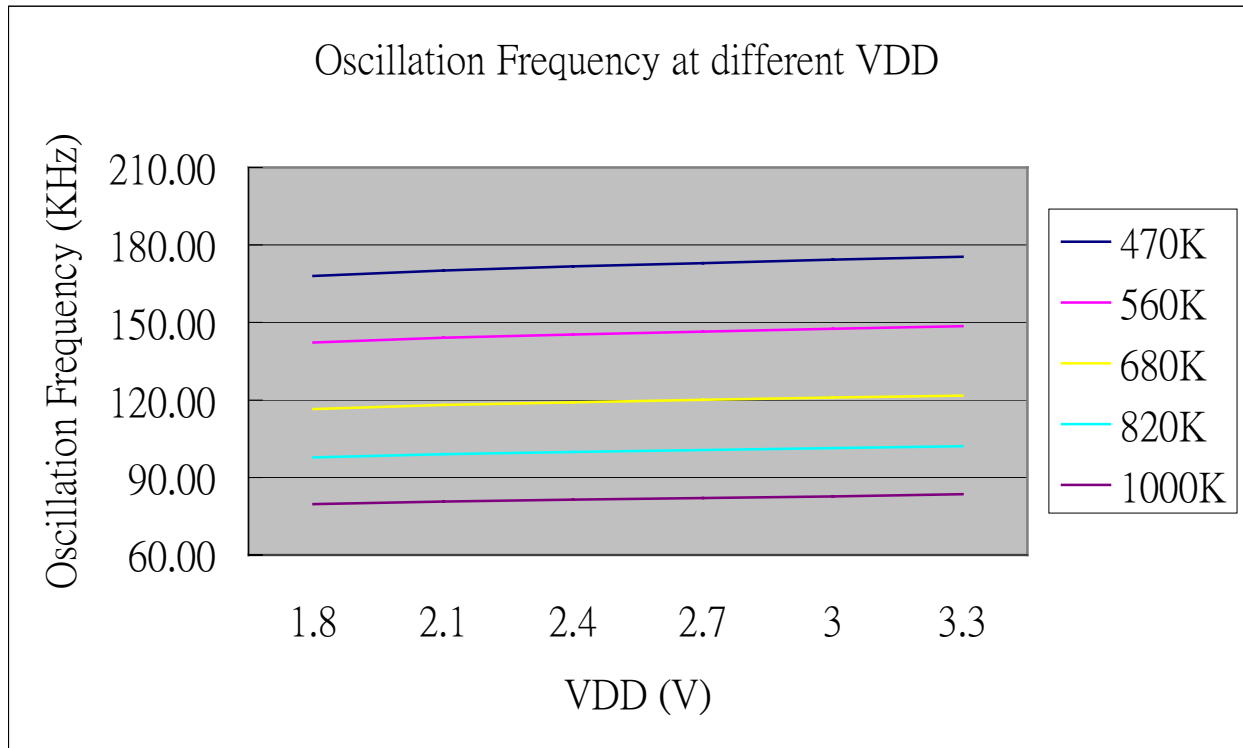

Figure 8 - Oscillation Frequency at different VDD at 25°C

Table 12 – Parallel Timing Characteristics 1 ($T_A = -20$ to 85°C , $V_{DD} = 1.8$ to 3.3V , $V_{SS} = 0\text{V}$)

Symbol	Parameter	Min	Typ	Max	Unit
t_{cycle}	Clock Cycle Time (write cycle)	166	-	-	ns
t_{AS}	Address Setup Time	0	-	-	ns
t_{AH}	Address Hold Time	0	-	-	ns
t_{DSW}	Write Data Setup Time	30	-	-	ns
t_{DHW}	Write Data Hold Time	5	-	-	ns
t_{DHR}	Read Data Hold Time	15	-	-	ns
t_{OH}	Output Disable Time	-	-	50	ns
t_{ACC}	Access Time (RAM) Access Time (command)	-	-	140	ns
PW_{CSL}	Chip Select Low Pulse Width (read RAM) Chip Select Low Pulse Width (read Command) Chip Select Low Pulse Width (write)	70	-	-	ns
PW_{CSH}	Chip Select High Pulse Width (read) Chip Select High Pulse Width (write)	40	-	-	ns
t_{R}	Rise Time	-	-	10	ns
t_{F}	Fall Time	-	-	10	ns

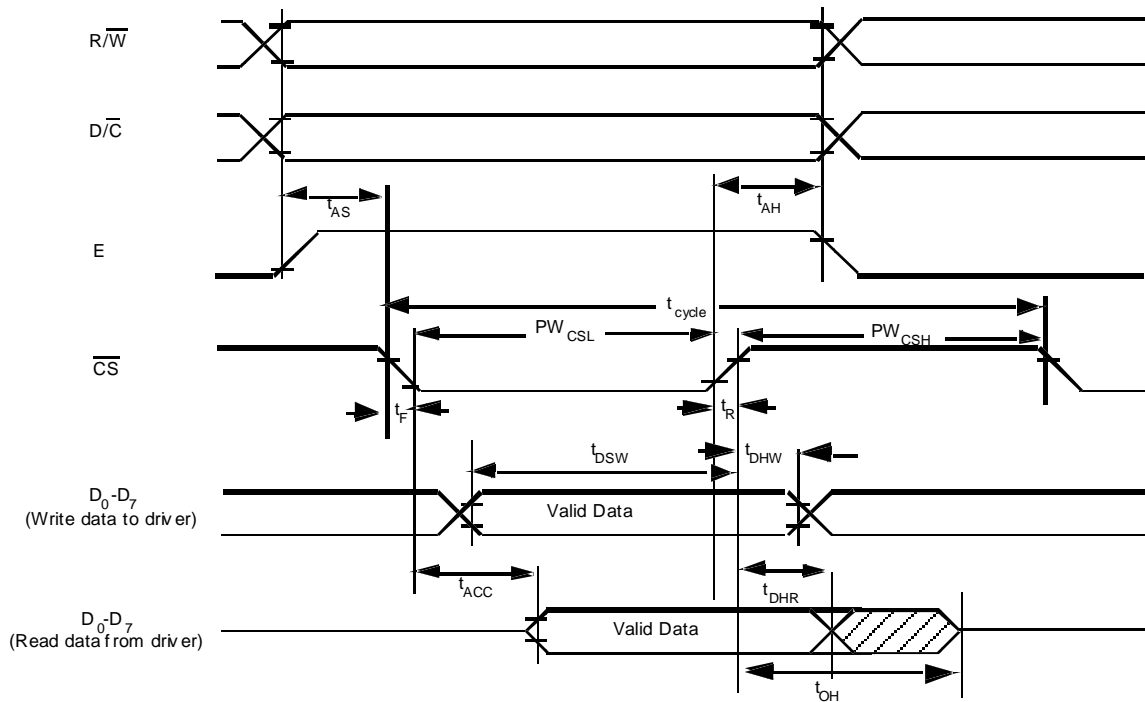

Figure 9 – Parallel 6800-series Interface Timing Characteristics (PS0 = H, PS1 = H)

Table 13 – Parallel Timing Characteristics 2 ($T_A = -20$ to 85°C , $V_{DD} = 1.8$ to 3.3V , $V_{SS} = 0\text{V}$)

Symbol	Parameter	Min	Typ	Max	Unit
t_{cycle}	Clock Cycle Time (write cycle)	166	-	-	ns
t_{AS}	Address Setup Time	0	-	25	ns
t_{AH}	Address Hold Time	0	-	-	ns
t_{DSW}	Write Data Setup Time	30	-	-	ns
t_{DHW}	Write Data Hold Time	5	-	-	ns
t_{DHR}	Read Data Hold Time	15	-	-	ns
t_{OH}	Output Disable Time	-	-	50	ns
t_{ACC}	Access Time (RAM) Access Time (command)	-	-	140	ns
PW_{CSL}	Chip Select Low Pulse Width (read RAM) Chip Select Low Pulse Width (read Command) Chip Select Low Pulse Width (write)	70	-	-	ns
PW_{CSH}	Chip Select High Pulse Width (read) Chip Select High Pulse Width (write)	40	-	-	ns
t_{R}	Rise Time	-	-	10	ns
t_{F}	Fall Time	-	-	10	ns

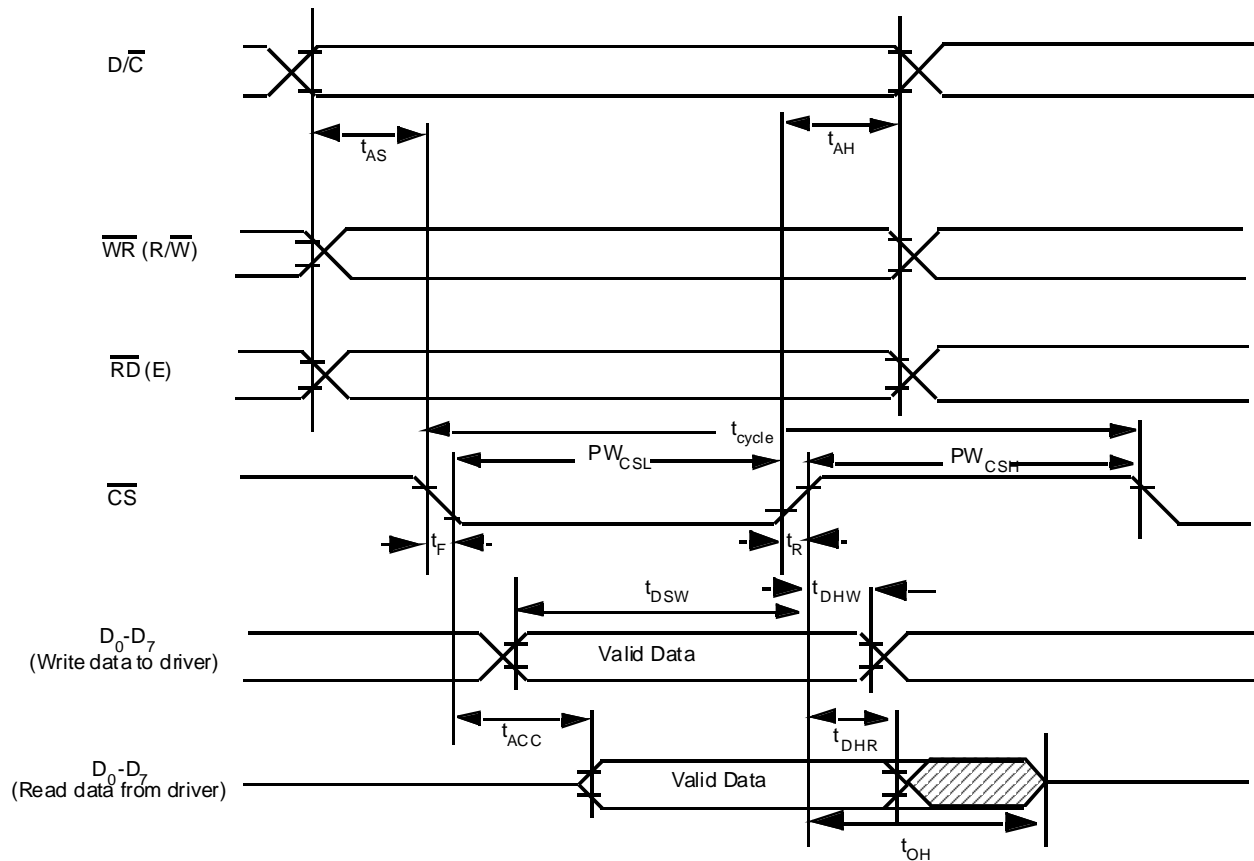

Figure 10 - Parallel 8080-series Interface Timing Characteristics (PS0 = H, PS1 = L)

Table 14 – Serial Timing Characteristics ($T_A = -20$ to 85°C , $V_{DD} = 1.8$ to 3.3V , $V_{SS} = 0\text{V}$)

Symbol	Parameter	Min	Typ	Max	Unit
t_{cycle}	Clock Cycle Time	58.8	-	-	ns
t_{AS}	Address Setup Time	14	-	-	ns
t_{AH}	Address Hold Time	30	-	-	ns
t_{CSS}	Chip Select Setup Time	30	-	-	ns
t_{CSH}	Chip Select Hold Time	$\frac{1}{2}t_{\text{cycle}}$	-	-	ns
t_{DSW}	Write Data Setup Time	30	-	-	ns
t_{DHW}	Write Data Hold Time	30	-	-	ns
t_{CLKL}	Clock Low Time	30	-	-	ns
t_{CLKH}	Clock High Time	30	-	-	ns
t_{R}	Rise Time	-	-	10	ns
t_{F}	Fall Time	-	-	10	ns

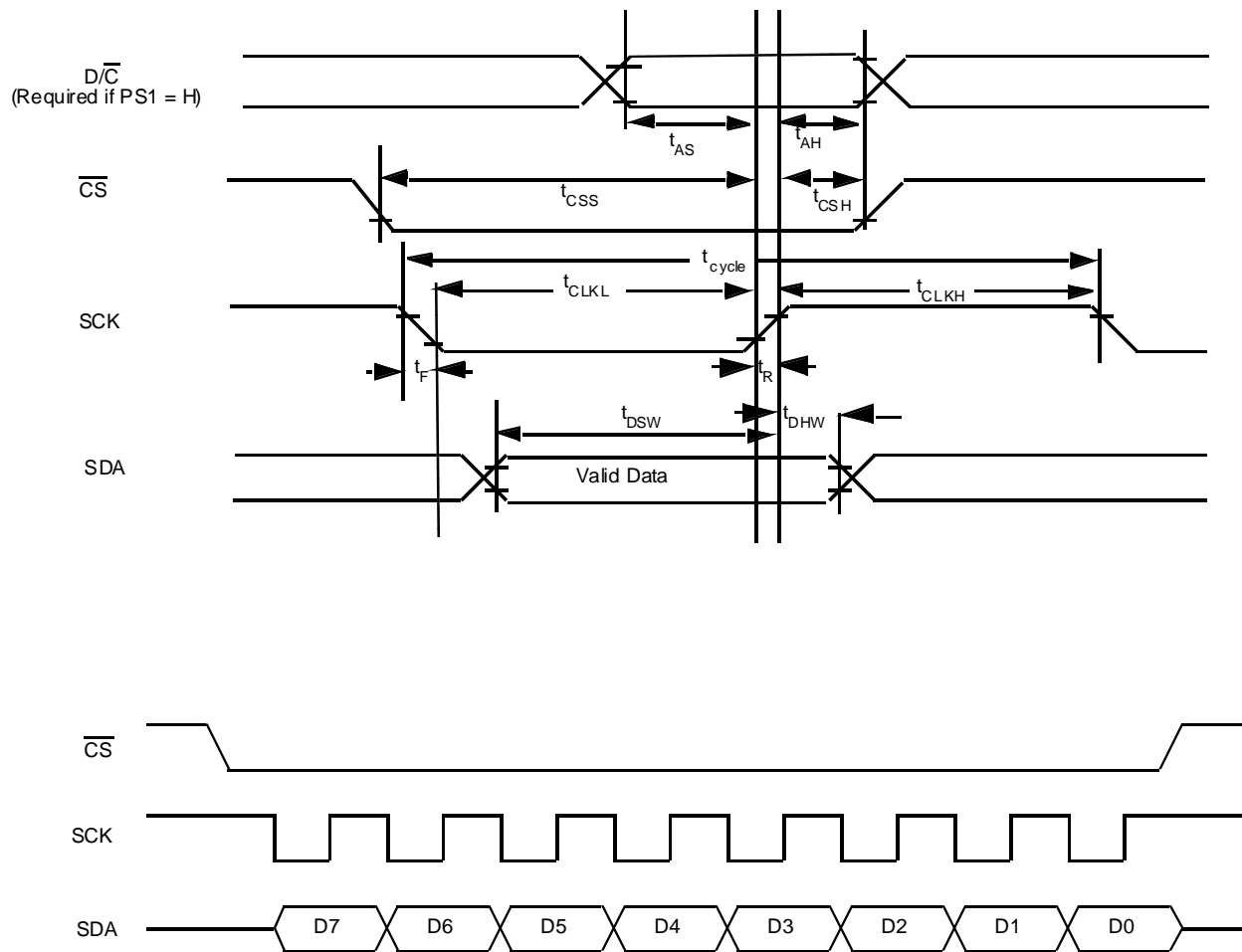

Figure 11- Serial Timing Characteristics (PS0 = L)

12 APPLICATION CIRCUIT

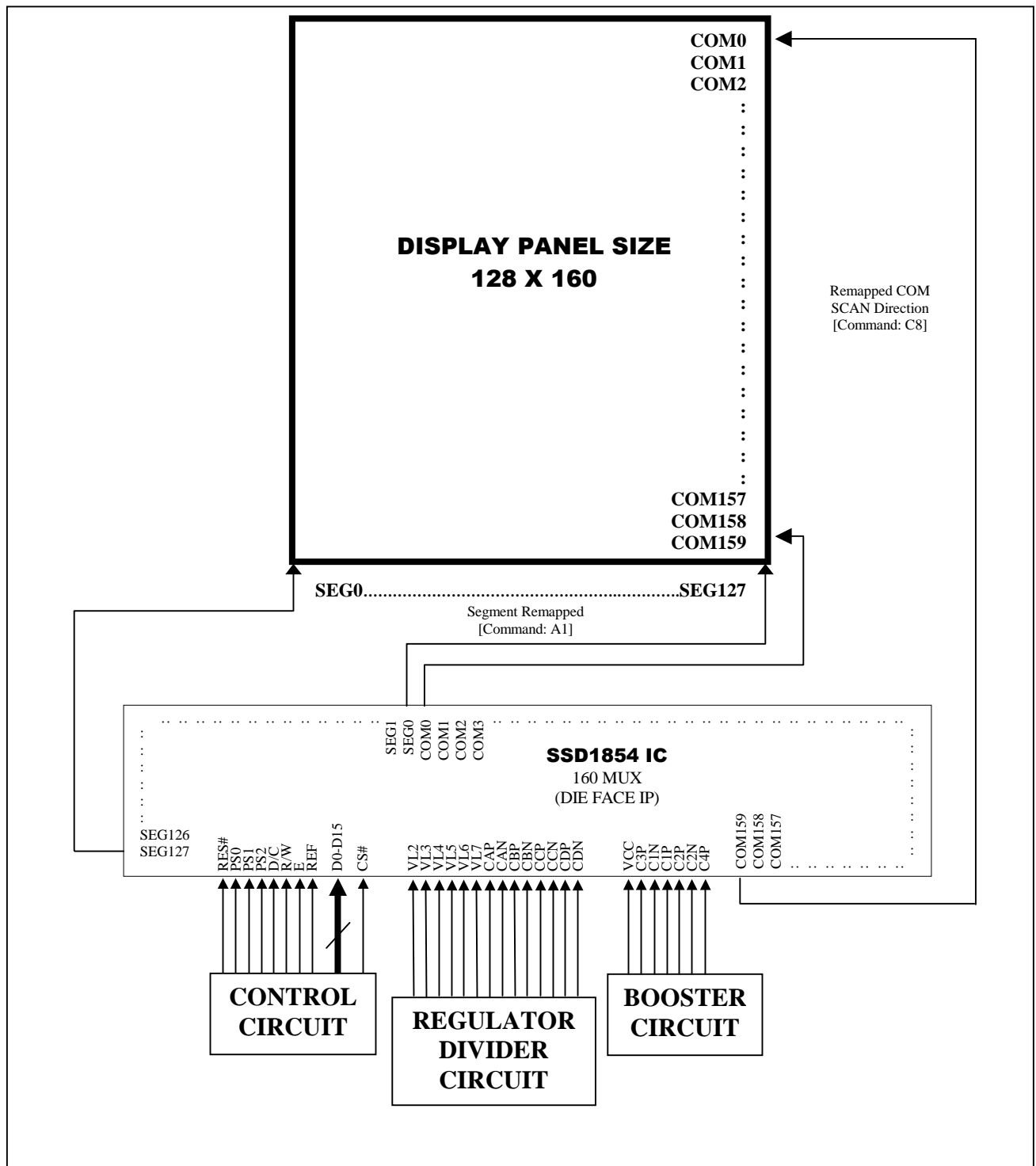
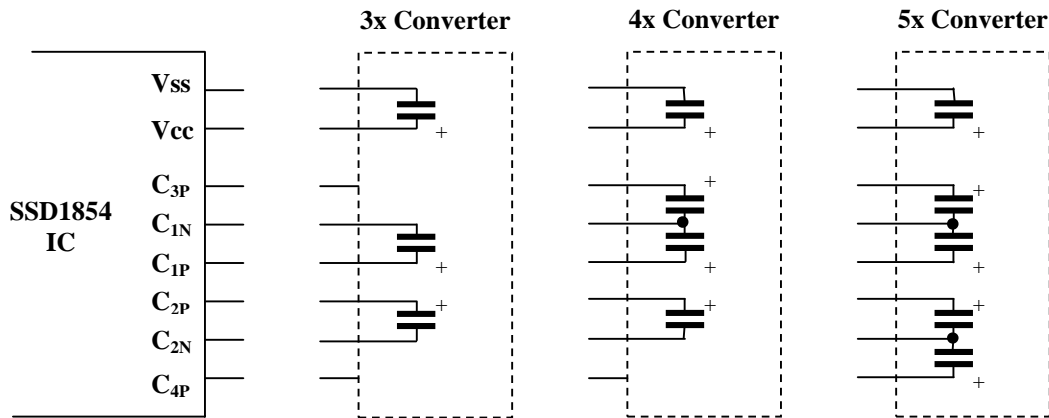

Figure 12 – LCD Pins Connection of SSD1854Z

12.1 DC-DC Converter Circuit Configuration



*Note: Capacitor value = $1\mu\text{F}$ to $4.7\mu\text{F}$, which is depended on the LCD panel characteristic

12.2 Bias Divider Circuit Configuration

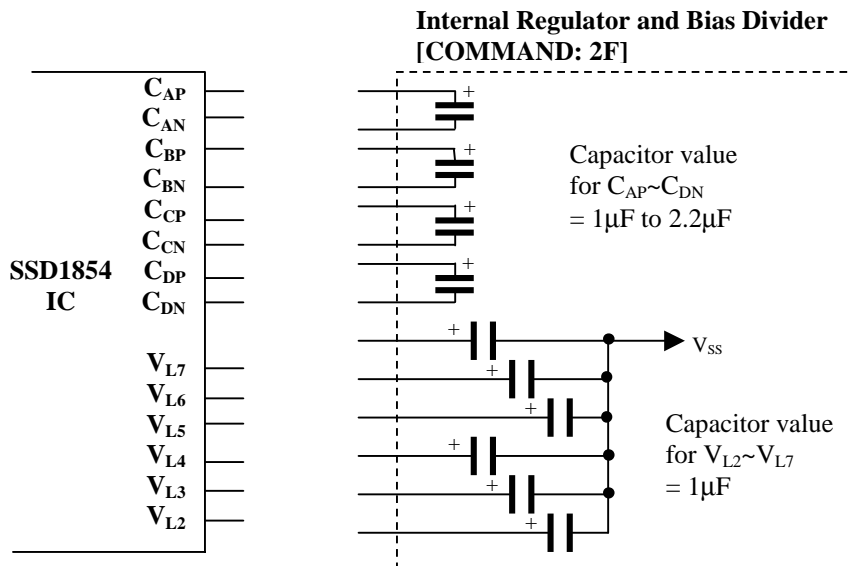

12.3 Parallel Interface Configuration (Read / Write)

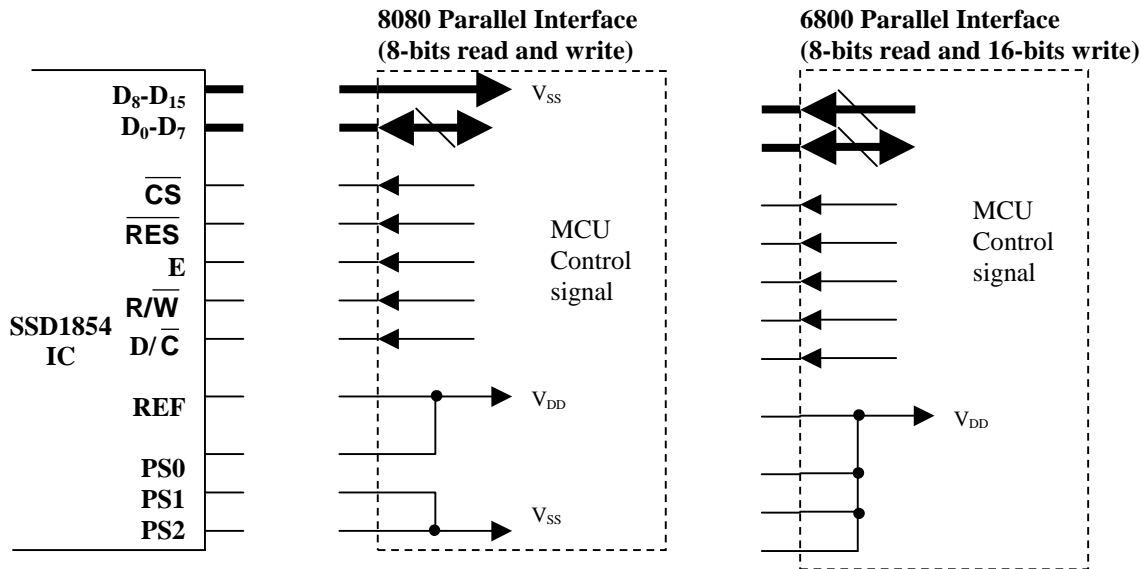

12.4 Serial Interface Configuration (Write Only)

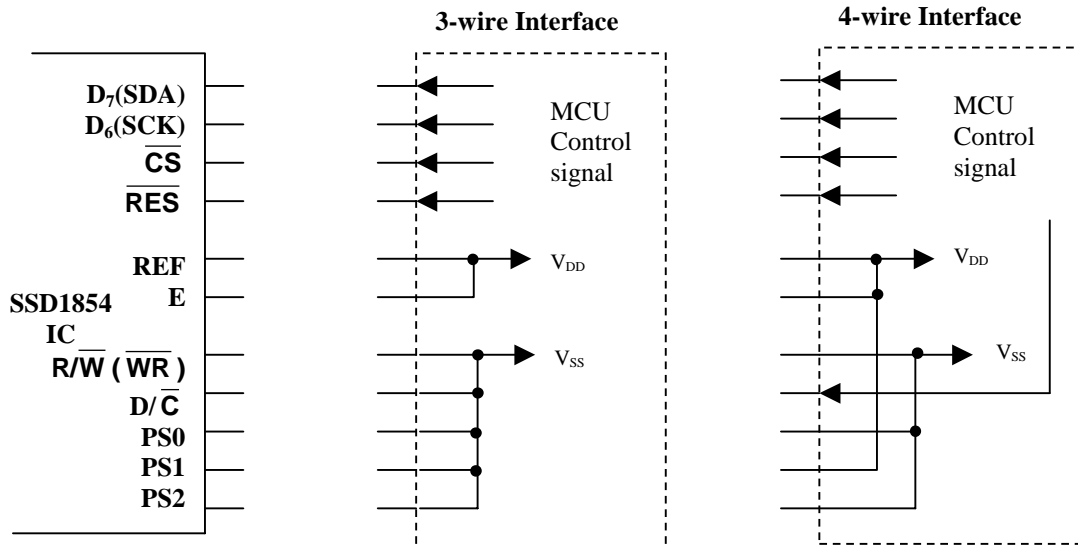

13 APPENDIXA

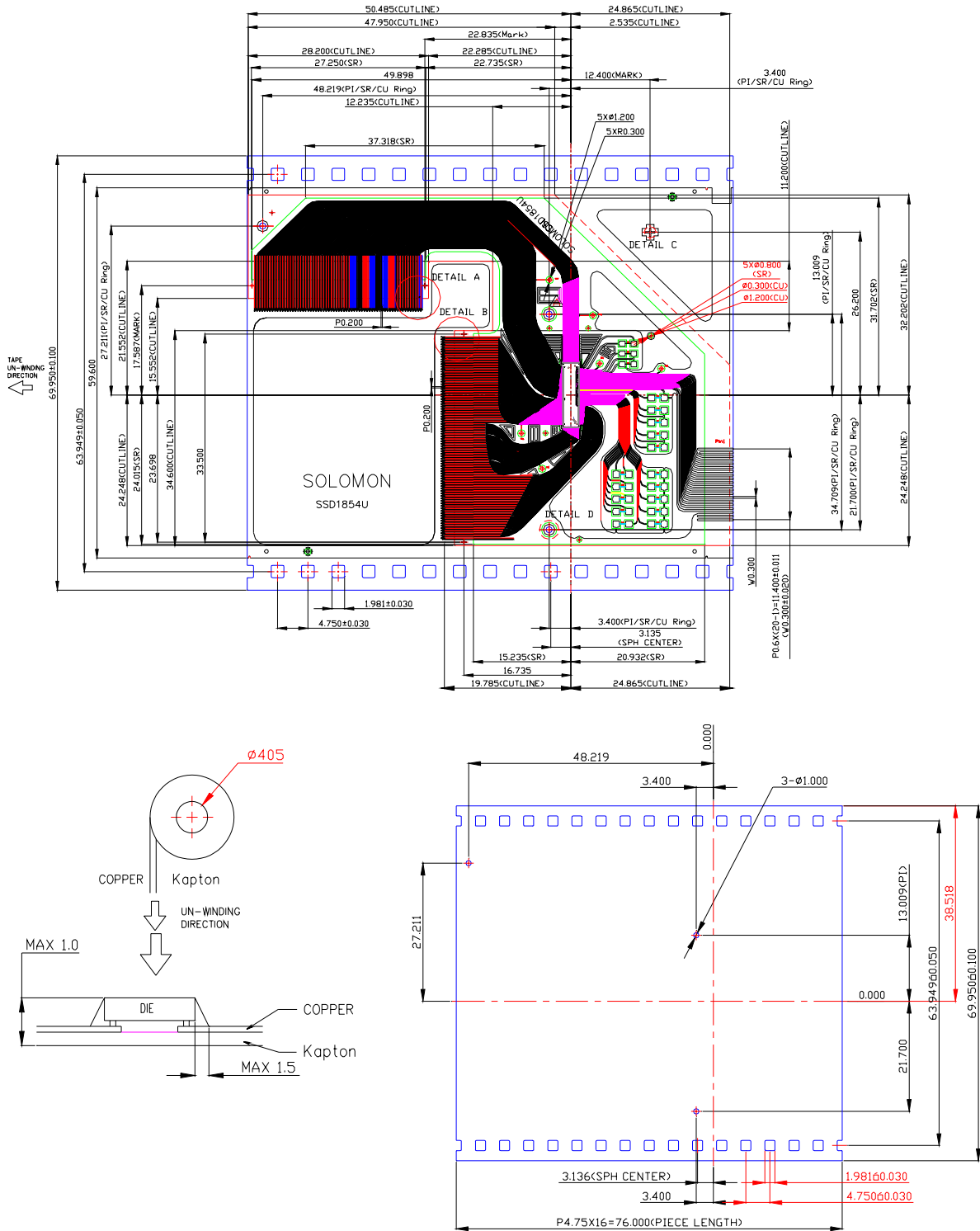

Figure 13 – SSD1854U COF Drawing 1

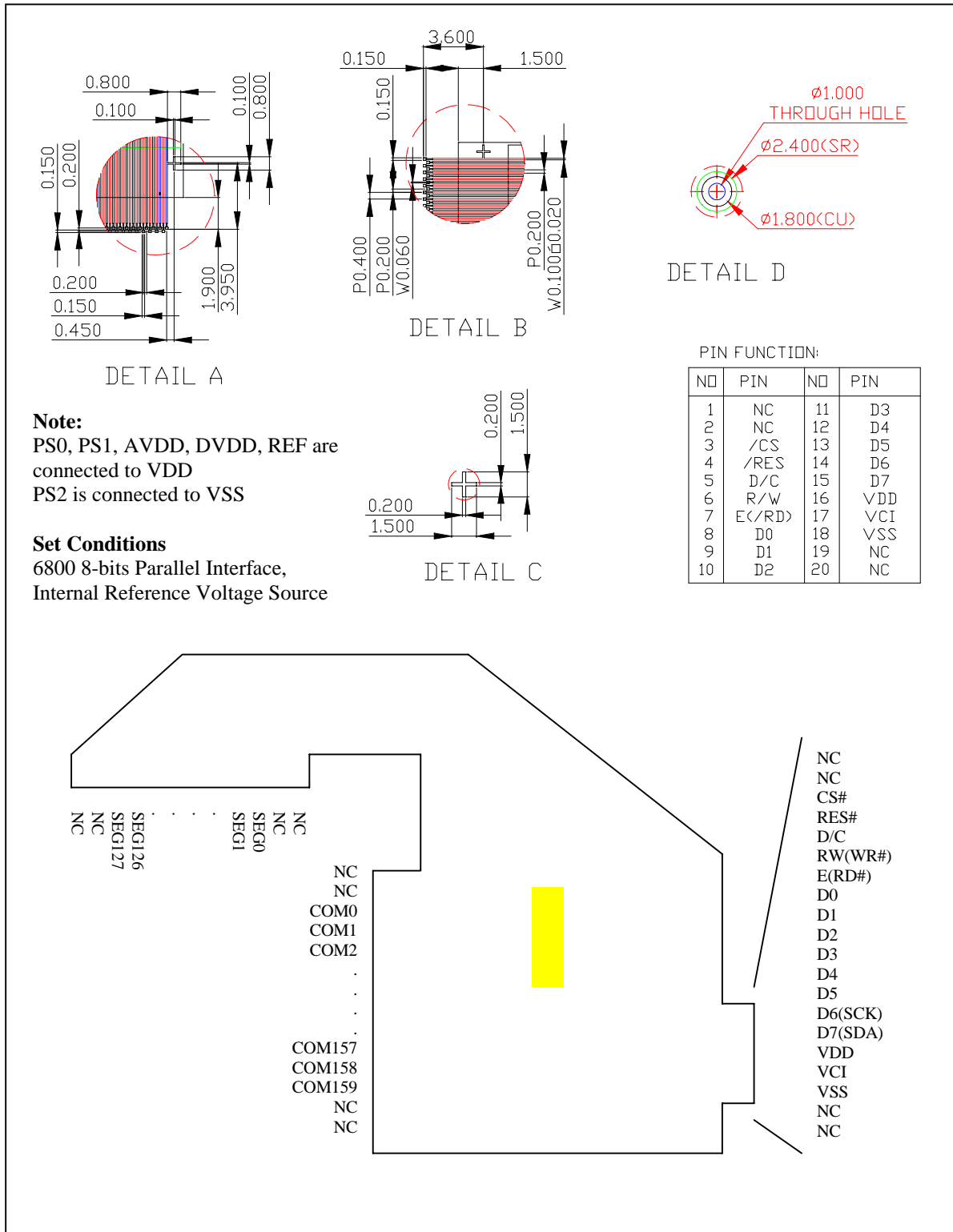

Figure 14 – SSD1854U COF Drawing 2

Solomon Systech reserves the right to make changes without further notice to any products herein. Solomon Systech makes no warranty, representation or guarantee regarding the suitability of its products for any particular purpose, nor does Solomon Systech assume any liability arising out of the application or use of any product or circuit, and specifically disclaims any and all liability, including without limitation consequential or incidental damages. "Typical" parameters can and do vary in different applications. All operating parameters, including "Typicals" must be validated for each customer application by customer's technical experts. Solomon Systech does not convey any license under its patent rights nor the rights of others. Solomon Systech products are not designed, intended, or authorized for use as components in systems intended for surgical implant into the body, or other applications intended to support or sustain life, or for any other application in which the failure of the Solomon Systech product could create a situation where personal injury or death may occur. Should Buyer purchase or use Solomon Systech products for any such unintended or unauthorized application, Buyer shall indemnify and hold Solomon Systech and its offices, employees, subsidiaries, affiliates, and distributors harmless against all claims, costs, damages, and expenses, and reasonable attorney fees arising out of, directly or indirectly, any claim of personal injury or death associated with such unintended or unauthorized use, even if such claim alleges that Solomon Systech was negligent regarding the design or manufacture of the part.