

SSD1317

Advance Information

128 x 96 Dot Matrix
OLED/PLED Segment/Common Driver with Controller

This document contains information on a new product. Specifications and information herein are subject to change without notice.

Appendix: IC Revision history of SSD1317 Specification

Version	Change Items	Effective Date
1.0	1 st Release	21-Dec-15

**Confidential to
Kunshan Visionox Display Co., Ltd.**

CONTENTS

1	GENERAL DESCRIPTION	6
2	FEATURES.....	6
3	ORDERING INFORMATION	6
4	BLOCK DIAGRAM	7
5	PIN DESCRIPTION	8
6	FUNCTIONAL BLOCK DESCRIPTIONS	11
6.1	MCU INTERFACE SELECTION.....	11
6.1.1	MCU Parallel 6800-series Interface.....	11
6.1.2	MCU Parallel 8080-series Interface.....	12
6.1.3	MCU Serial Interface (4-wire SPI).....	13
6.1.4	MCU Serial Interface (3-wire SPI).....	14
6.1.5	MCU I ² C Interface.....	15
6.2	COMMAND DECODER	18
6.3	OSCILLATOR CIRCUIT AND DISPLAY TIME GENERATOR.....	18
6.4	RESET CIRCUIT	19
6.5	SEGMENT DRIVERS / COMMON DRIVERS	19
6.6	GRAPHIC DISPLAY DATA RAM (GDDRAM).....	20
6.7	SEG/COM DRIVING BLOCK	21
6.8	POWER ON AND OFF SEQUENCE.....	22
7	MAXIMUM RATINGS	23
8	DC CHARACTERISTICS	24
9	AC CHARACTERISTICS	25
10	APPLICATION EXAMPLE.....	31

TABLES

TABLE 3-1: ORDERING INFORMATION	6
TABLE 5-1: PIN DESCRIPTION	8
TABLE 5-2 : BUS INTERFACE SELECTION	8
TABLE 6-1 : MCU INTERFACE ASSIGNMENT UNDER DIFFERENT BUS INTERFACE MODE	11
TABLE 6-2 : CONTROL PINS OF 6800 INTERFACE.....	11
TABLE 6-3 : CONTROL PINS OF 8080 INTERFACE.....	13
TABLE 6-4 : CONTROL PINS OF 4-WIRE SERIAL INTERFACE.....	13
TABLE 6-5 : CONTROL PINS OF 3-WIRE SERIAL INTERFACE.....	14
TABLE 7-1 : MAXIMUM RATINGS	23
TABLE 8-1 : DC CHARACTERISTICS	24
TABLE 9-1 : AC CHARACTERISTICS	25
TABLE 9-2 : 6800-SERIES MCU PARALLEL INTERFACE TIMING CHARACTERISTICS	26
TABLE 9-3 : 8080-SERIES MCU PARALLEL INTERFACE TIMING CHARACTERISTICS	27
TABLE 9-4 : SERIAL INTERFACE TIMING CHARACTERISTICS (4-WIRE SPI)	28
TABLE 9-5 : SERIAL INTERFACE TIMING CHARACTERISTICS (3-WIRE SPI)	29
TABLE 9-6 : I ² C INTERFACE TIMING CHARACTERISTICS	30

Confidential to
Kunshan Visionox Display Co., Ltd.

FIGURES

FIGURE 4-1: SSD1317 BLOCK DIAGRAM	7
FIGURE 6-1 : DATA READ BACK PROCEDURE - INSERTION OF DUMMY READ	12
FIGURE 6-2 : EXAMPLE OF WRITE PROCEDURE IN 8080 PARALLEL INTERFACE MODE.....	12
FIGURE 6-3 : EXAMPLE OF READ PROCEDURE IN 8080 PARALLEL INTERFACE MODE	12
FIGURE 6-4 : DISPLAY DATA READ BACK PROCEDURE - INSERTION OF DUMMY READ.....	13
FIGURE 6-5 : WRITE PROCEDURE IN 4-WIRE SERIAL INTERFACE MODE.....	14
FIGURE 6-6 : WRITE PROCEDURE IN 3-WIRE SERIAL INTERFACE MODE.....	14
FIGURE 6-7 : I ² C-BUS DATA FORMAT	16
FIGURE 6-8 : DEFINITION OF THE START AND STOP CONDITION	17
FIGURE 6-9 : DEFINITION OF THE ACKNOWLEDGEMENT CONDITION	17
FIGURE 6-10 : DEFINITION OF THE DATA TRANSFER CONDITION	17
FIGURE 6-11 : OSCILLATOR CIRCUIT AND DISPLAY TIME GENERATOR	18
FIGURE 6-12 : SEGMENT OUTPUT WAVEFORM IN THREE PHASES	19
FIGURE 6-13 : GDDRAM PAGES STRUCTURE.....	20
FIGURE 6-14 : ENLARGEMENT OF GDDRAM (NO ROW RE-MAPPING AND COLUMN-REMAPPING).....	20
FIGURE 6-15 : I _{REF} CURRENT SETTING BY RESISTOR VALUE	21
FIGURE 6-16 : THE POWER ON SEQUENCE.....	22
FIGURE 6-17 : THE POWER OFF SEQUENCE.....	22
FIGURE 9-1 : 6800-SERIES MCU PARALLEL INTERFACE CHARACTERISTICS.....	26
FIGURE 9-2 : 8080-SERIES PARALLEL INTERFACE CHARACTERISTICS.....	27
FIGURE 9-3 : SERIAL INTERFACE CHARACTERISTICS (4-WIRE SPI)	28
FIGURE 9-4 : SERIAL INTERFACE CHARACTERISTICS (3-WIRE SPI)	29
FIGURE 9-5 : I ² C INTERFACE TIMING CHARACTERISTICS	30
FIGURE 10-1 : APPLICATION EXAMPLE OF SSD1317Z	31

Confidential to
Kunshan Visionox Display Co., Ltd.

1 GENERAL DESCRIPTION

SSD1317 is a single-chip CMOS OLED/PLED driver with controller for organic/polymer light emitting diode dot-matrix graphic display. It consists of 128 segments and 96 commons. This IC is designed for Common Cathode type OLED/PLED panel.

SSD1317 embeds with contrast control, display RAM and oscillator, which reduce the number of external components and power consumption. It has 256-step contrast. Data/Commands are sent from generic MCU through the hardware selectable 6800/8080 series compatible Parallel Interface, I2C interface or Serial Peripheral Interface. SSD1317 is suitable for many compact portable applications which require high display brightness for sunlight readability such as wearable electronics, Wifi routers, etc.

2 FEATURES

- Resolution: 128 x 96 dot matrix panel
- Power supply
 - $V_{DD} = 1.65V - 3.3V$ (for IC logic)
 - $V_{CC} = 7.0V - 16.5V$ (for Panel driving)
- Segment maximum source current: 600uA
- Common maximum sink current: 76.8mA
- Embedded 128 x 96 bit SRAM display buffer
- Pin selectable MCU Interfaces:
 - 8 bits 6800/8080-series parallel Interface
 - 3/4 wire Serial Peripheral Interface
 - I²C Interface
- Screen saving infinite content scrolling function
- Internal or external I_{REF} selection
- RAM write synchronization signal
- Programmable Frame Rate and Multiplexing Ratio
- Row Re-mapping and Column Re-mapping
- Power On Reset (POR)
- On-Chip Oscillator
- Chip layout for COG, COF
- Wide range of operating temperature: -40°C to 85°C

3 ORDERING INFORMATION

Table 3-1: Ordering Information

Ordering Part Number	SEG	COM	Package Form	Remark
SSD1317Z	128	96	COG	<ul style="list-style-type: none">○ Min SEG pad pitch : 29um○ Min COM pad pitch : 35um○ Min I/O pad pitch : 45um○ Die thickness: 250um○ Bump height: nominal 9um

4 BLOCK DIAGRAM

Figure 4-1: SSD1317 Block Diagram

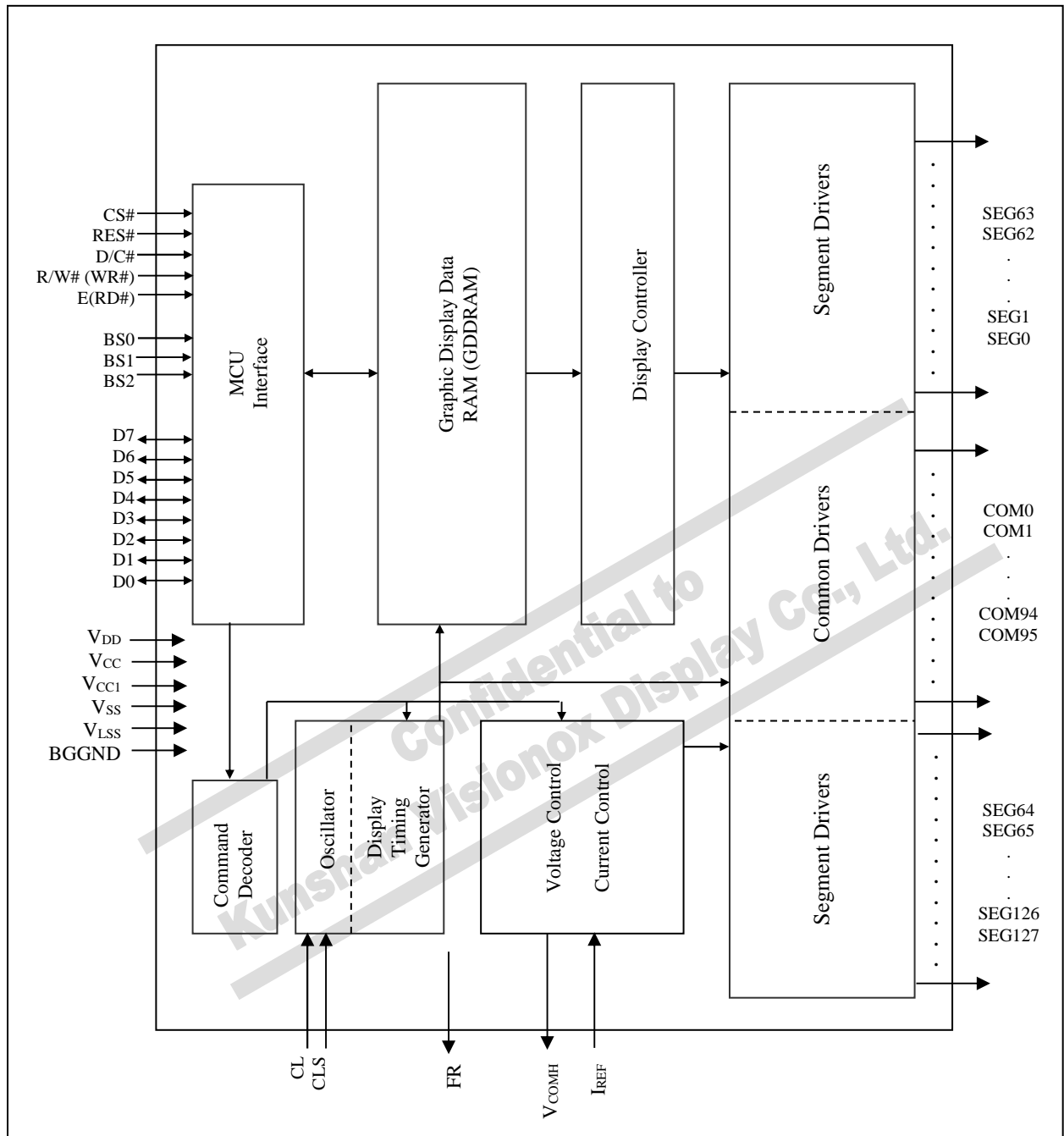

5 PIN DESCRIPTION

Key:

I = Input	NC = Not Connected
O =Output	Pull LOW= connect to Ground
I/O = Bi-directional (input/output)	Pull HIGH= connect to V _{DD}
P = Power pin	

Table 5-1: Pin Description

Pin Name	Pin Type	Description												
V _{DD}	P	Power supply pin for core logic operation.												
V _{CC}	P	Power supply for panel driving voltage. This is also the most positive power voltage supply pin.												
V _{CC1}	P	Clean power supply for high voltage circuit. It must be connected to V _{CC} externally.												
BGGND	P	Reserved pin. It must be connected to ground.												
V _{SS}	P	Ground pin. It must be connected to external ground.												
V _{LSS}	P	Analog system ground pin. It must be connected to external ground.												
VSL	P	This is segment voltage (output low level) reference pin. When external VSL is not used, this pin must be connected to V _{LSS} externally. When external VSL is used, connect with resistor and diode to ground (details depends on application).												
V _{LH}	P	Logic high (same voltage level as V _{DD}) for internal connection of input and I/O pins. No need to connect to external power source.												
V _{LL}	P	Logic low (same voltage level as V _{SS}) for internal connection of input and I/O pins. No need to connect to external ground.												
V _{COMH}	P	COM signal deselected voltage level. A capacitor should be connected between this pin and V _{SS} .												
VBREF	O	This is a reserved pin. It should be kept NC.												
BS[2:0]	I	MCU bus interface selection pins. Select appropriate logic setting as described in the following table. BS2, BS1 and BS0 are pin select. <div style="text-align: center;"> <p>Table 5-2 : Bus Interface selection</p> <table border="1"> <thead> <tr> <th>BS[2:0]</th> <th>Interface</th> </tr> </thead> <tbody> <tr> <td>000</td> <td>4 line SPI</td> </tr> <tr> <td>001</td> <td>3 line SPI</td> </tr> <tr> <td>010</td> <td>I²C</td> </tr> <tr> <td>110</td> <td>8-bit 8080 parallel</td> </tr> <tr> <td>100</td> <td>8-bit 6800 parallel</td> </tr> </tbody> </table> </div> <p>Note ⁽¹⁾ 0 is connected to V_{SS} ⁽²⁾ 1 is connected to V_{DD}</p>	BS[2:0]	Interface	000	4 line SPI	001	3 line SPI	010	I ² C	110	8-bit 8080 parallel	100	8-bit 6800 parallel
BS[2:0]	Interface													
000	4 line SPI													
001	3 line SPI													
010	I ² C													
110	8-bit 8080 parallel													
100	8-bit 6800 parallel													

Pin Name	Pin Type	Description
I _{REF}	I	This pin is the segment output current reference pin. I _{REF} is supplied externally. A resistor should be connected between this pin and V _{SS} to maintain the current around 18.75uA. Please refer to Figure 6-15 for the details of resistor value. When internal I _{REF} is used, this pin should be kept NC.
CL	I	This is external clock input pin. When internal clock is enabled (i.e. HIGH in CLS pin), this pin is not used and should be connected to V _{SS} . When internal clock is disabled (i.e. LOW in CLS pin), this pin is the external clock source input pin.
CLS	I	This is internal clock enable pin. When it is pulled HIGH (i.e. connect to V _{DD}), internal clock is enabled. When it is pulled LOW, the internal clock is disabled; an external clock source must be connected to the CL pin for normal operation.
CS#	I	This pin is the chip select input connecting to the MCU. The chip is enabled for MCU communication only when CS# is pulled LOW (active LOW).
RES#	I	This pin is reset signal input. When the pin is pulled LOW, initialization of the chip is executed. Keep this pin pull HIGH during normal operation.
D/C#	I	This pin is Data/Command control pin connecting to the MCU. When the pin is pulled HIGH, the data at D[7:0] will be interpreted as data. When the pin is pulled LOW, the data at D[7:0] will be transferred to a command register. In I ² C mode, this pin acts as SA0 for slave address selection. When 3-wire serial interface is selected, this pin must be connected to V _{SS} . For detail relationship to MCU interface signals, refer to Timing Characteristics Diagrams Figure 9-1 to Figure 9-3.
R/W# (WR#)	I	This pin is read / write control input pin connecting to the MCU interface. When 6800 interface mode is selected, this pin will be used as Read/Write (R/W#) selection input. Read mode will be carried out when this pin is pulled HIGH and write mode when LOW. When 8080 interface mode is selected, this pin will be the Write (WR#) input. Data write operation is initiated when this pin is pulled LOW and the chip is selected. When serial or I ² C interface is selected, this pin must be connected to V _{SS} .
E (RD#)	I	This pin is MCU interface input. When 6800 interface mode is selected, this pin will be used as the Enable (E) signal. Read/write operation is initiated when this pin is pulled HIGH and the chip is selected. When 8080 interface mode is selected, this pin receives the Read (RD#) signal. Read operation is initiated when this pin is pulled LOW and the chip is selected. When serial or I ² C interface is selected, this pin must be connected to V _{SS} .

Pin Name	Pin Type	Description
D[7:0]	I/O	These pins are bi-directional data bus connecting to the MCU data bus. Unused pins are recommended to tie LOW. When serial interface mode is selected, D0 will be the serial clock input: SCLK; D1 will be the serial data input: SDIN. When I ² C mode is selected, D2, D1 should be tied together and serve as SDA _{out} , SDA _{in} in application and D0 is the serial clock input, SCL.
FR	O	This pin outputs RAM write synchronization signal. Proper timing between MCU data writing and frame display timing can be achieved to prevent tearing effect. It should be kept NC if it is not used.
T0	I/O	This is a reserved pin. It should be kept NC.
T1	I/O	This is a reserved pin. It should be kept NC.
SEG0 ~ SEG127	O	These pins provide the OLED segment driving signals. These pins are V _{SS} state when display is OFF.
COM0 ~ COM95	O	These pins provide the Common switch signals to the OLED panel. These pins are in high impedance state when display is OFF.
TR[10:0]	-	Reserved pin. It should be kept NC.
NC	-	This is dummy pin. It should be kept NC.

Confidential to
Kunshan Visionox Display Co., Ltd.

6 FUNCTIONAL BLOCK DESCRIPTIONS

6.1 MCU Interface selection

SSD1317 MCU interface consist of 8 data pins and 5 control pins. The pin assignment at different interface mode is summarized in Table 6-1. Different MCU mode can be set by hardware selection on BS[2:0] pins (please refer to Table 5-2 for BS[2:0] setting).

Table 6-1 : MCU interface assignment under different bus interface mode

Pin Name Bus Interface	Data/Command Interface								Control Signal				
	D7	D6	D5	D4	D3	D2	D1	D0	E	R/W#	CS#	D/C#	RES#
8-bit 8080	D[7:0]								RD#	WR#	CS#	D/C#	RES#
8-bit 6800	D[7:0]								E	R/W#	CS#	D/C#	RES#
3-wire SPI	Tie LOW						SDIN	SCLK	Tie LOW		CS#	Tie LOW	RES#
4-wire SPI	Tie LOW						SDIN	SCLK	Tie LOW		CS#	D/C#	RES#
I ² C	Tie LOW					SDA _{OUT}	SDA _{IN}	SCL	Tie LOW			SA0	RES#

6.1.1 MCU Parallel 6800-series Interface

The parallel interface consists of 8 bi-directional data pins (D[7:0]), R/W#, D/C#, E and CS#.

A LOW in R/W# indicates WRITE operation and HIGH in R/W# indicates READ operation. A LOW in D/C# indicates COMMAND read/write and HIGH in D/C# indicates DATA read/write. The E input serves as data latch signal while CS# is LOW. Data is latched at the falling edge of E signal.

Table 6-2 : Control pins of 6800 interface

Function	E	R/W#	CS#	D/C#
Write command	↓	L	L	L
Read status	↓	H	L	L
Write data	↓	L	L	H
Read data	↓	H	L	H

Note

- ⁽¹⁾ ↓ stands for falling edge of signal
 H stands for HIGH in signal
 L stands for LOW in signal

In order to match the operating frequency of display RAM with that of the microprocessor, some pipeline processing is internally performed which requires the insertion of a dummy read before the first actual display data read. This is shown in Figure 6-1.

Figure 6-1 : Data read back procedure - insertion of dummy read

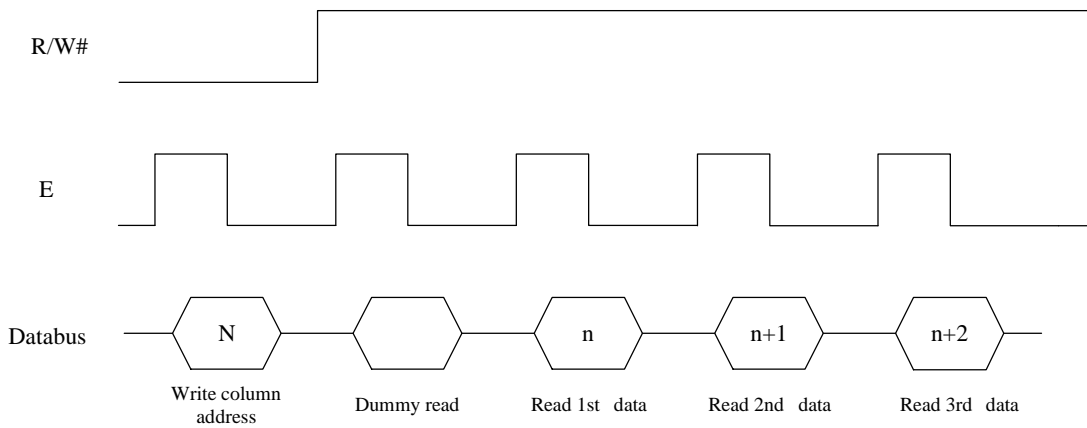

6.1.2 MCU Parallel 8080-series Interface

The parallel interface consists of 8 bi-directional data pins (D[7:0]), RD#, WR#, D/C# and CS#.

A LOW in D/C# indicates COMMAND read/write and HIGH in D/C# indicates DATA read/write.

A rising edge of RD# input serves as a data READ latch signal while CS# is kept LOW.

A rising edge of WR# input serves as a data/command WRITE latch signal while CS# is kept LOW.

Figure 6-2 : Example of Write procedure in 8080 parallel interface mode

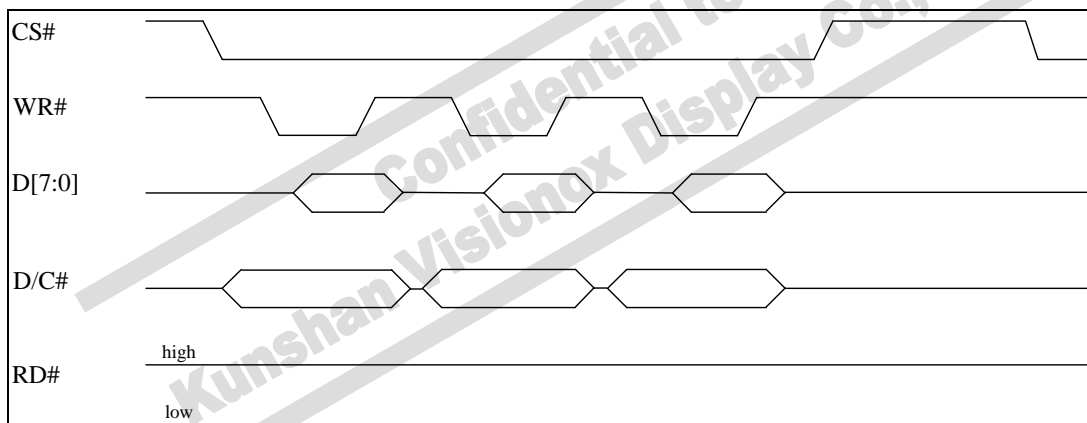

Figure 6-3 : Example of Read procedure in 8080 parallel interface mode

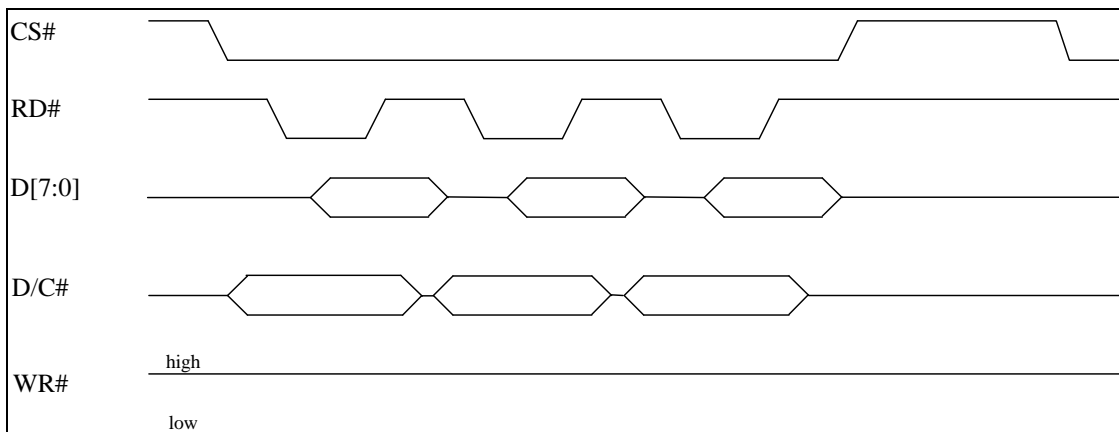

Table 6-3 : Control pins of 8080 interface

Function	RD#	WR#	CS#	D/C#
Write command	H	↑	L	L
Read status	↑	H	L	L
Write data	H	↑	L	H
Read data	↑	H	L	H

Note

- (1) ↑ stands for rising edge of signal
- (2) H stands for HIGH in signal
- (3) L stands for LOW in signal

In order to match the operating frequency of display RAM with that of the microprocessor, some pipeline processing is internally performed which requires the insertion of a dummy read before the first actual display data read. This is shown in Figure 6-4.

Figure 6-4 : Display data read back procedure - insertion of dummy read

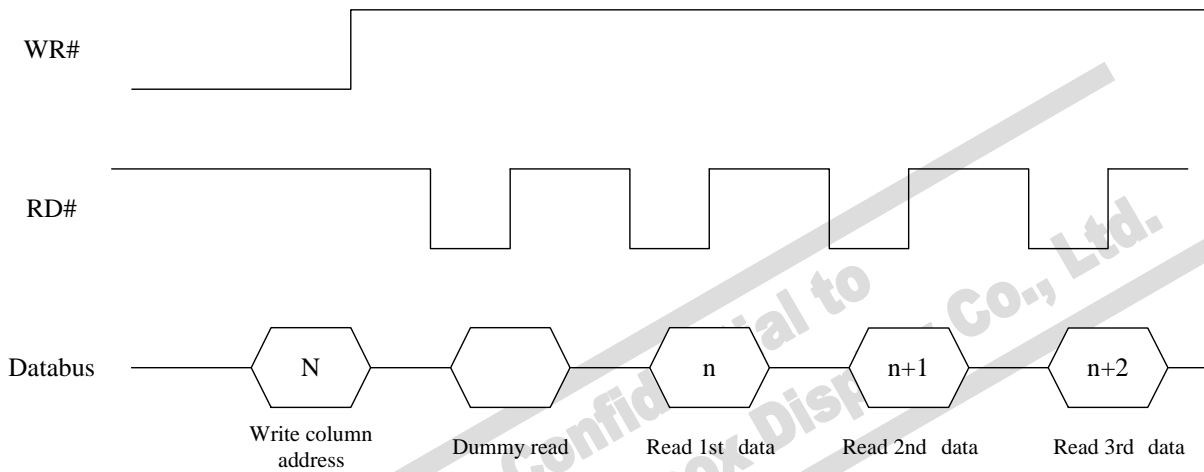

6.1.3 MCU Serial Interface (4-wire SPI)

The 4-wire serial interface consists of serial clock: SCLK, serial data: SDIN, D/C#, CS#. In 4-wire SPI mode, D0 acts as SCLK, D1 acts as SDIN. For the unused data pins from D2 to D7, E(RD#) and R/W#(WR#) can be connected to an external ground.

Table 6-4 : Control pins of 4-wire Serial interface

Function	E	R/W#	CS#	D/C#	D0
Write command	Tie LOW	Tie LOW	L	L	↑
Write data	Tie LOW	Tie LOW	L	H	↑

Note

- (1) H stands for HIGH in signal
- (2) L stands for LOW in signal
- (3) ↑ stands for rising edge of signal

SDIN is shifted into an 8-bit shift register on every rising edge of SCLK in the order of D7, D6, ... D0. D/C# is sampled on every eighth clock and the data byte in the shift register is written to the Graphic Display Data RAM (GDDRAM) or command register in the same clock.

Under serial mode, only write operations are allowed.

Figure 6-5 : Write procedure in 4-wire Serial interface mode

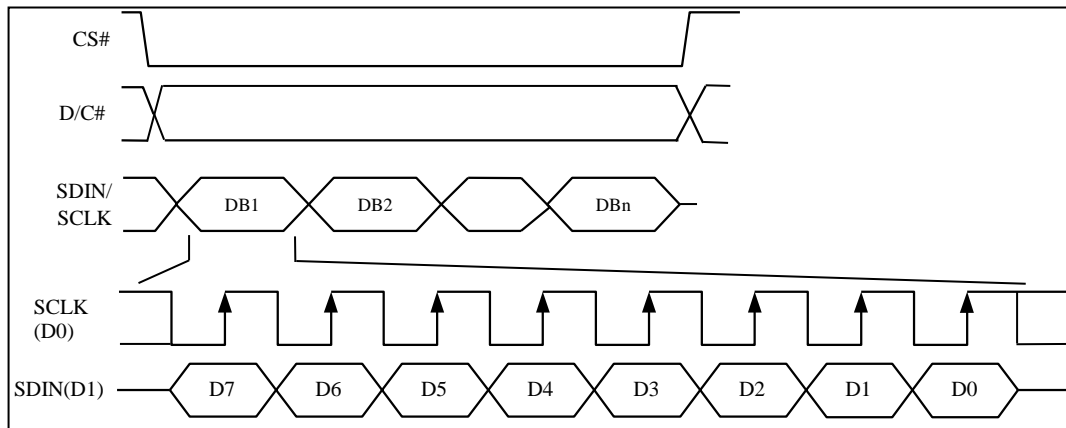

6.1.4 MCU Serial Interface (3-wire SPI)

The 3-wire serial interface consists of serial clock SCLK, serial data SDIN and CS#.

In 3-wire SPI mode, D0 acts as SCLK, D1 acts as SDIN. For the unused data pins from D2 to D7, R/W# (WR#), E(RD#) and D/C# can be connected to an external ground.

The operation is similar to 4-wire serial interface while D/C# pin is not used. There are altogether 9-bits will be shifted into the shift register on every ninth clock in sequence: D/C# bit, D7 to D0 bit. The D/C# bit (first bit of the sequential data) will determine the following data byte in the shift register is written to the Display Data RAM (D/C# bit = 1) or the command register (D/C# bit = 0).

Under serial mode, only write operations are allowed.

Table 6-5 : Control pins of 3-wire Serial interface

Function	E(RD#)	R/W#(WR#)	CS#	D/C#	D0
Write command	Tie LOW	Tie LOW	L	Tie LOW	↑
Write data	Tie LOW	Tie LOW	L	Tie LOW	↑

Note

(1) L stands for LOW in signal

(2) ↑ stands for rising edge of signal

Figure 6-6 : Write procedure in 3-wire Serial interface mode

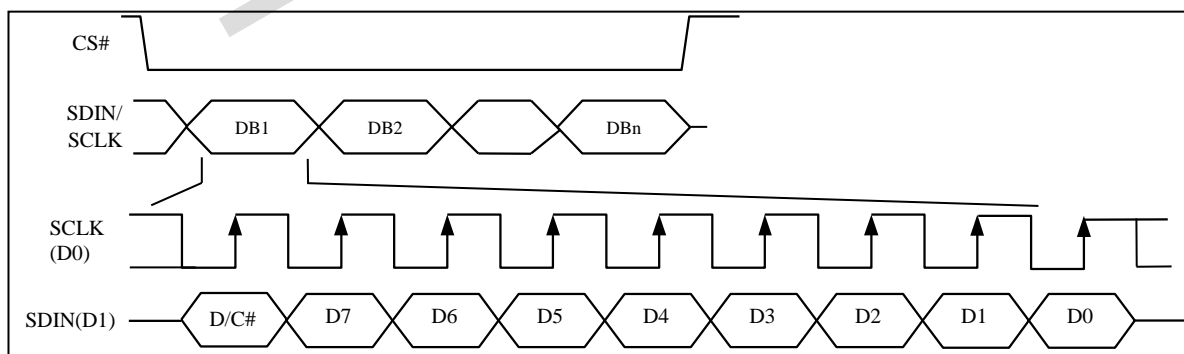

6.1.5 MCU I²C Interface

The I²C communication interface consists of slave address bit SA0, I²C-bus data signal SDA (SDA_{OUT}/D₂ for output and SDA_{IN}/D₁ for input) and I²C-bus clock signal SCL (D₀). Both the data and clock signals must be connected to pull-up resistors. RES# is used for the initialization of device.

a) Slave address bit (SA0)

SSD1317 has to recognize the slave address before transmitting or receiving any information by the I²C-bus. The device will respond to the slave address following by the slave address bit (“SA0” bit) and the read/write select bit (“R/W#” bit) with the following byte format,

b₇ b₆ b₅ b₄ b₃ b₂ b₁ b₀
0 1 1 1 1 0 SA0 R/W#

“SA0” bit provides an extension bit for the slave address. Either “0111100” or “0111101”, can be selected as the slave address of SSD1317. D/C# pin acts as SA0 for slave address selection.

“R/W#” bit is used to determine the operation mode of the I²C-bus interface. R/W#=1, it is in read mode. R/W#=0, it is in write mode.

b) I²C-bus data signal (SDA)

SDA acts as a communication channel between the transmitter and the receiver. The data and the acknowledgement are sent through the SDA.

It should be noticed that the ITO track resistance and the pulled-up resistance at “SDA” pin becomes a voltage potential divider. As a result, the acknowledgement would not be possible to attain a valid logic 0 level in “SDA”.

“SDA_{IN}” and “SDA_{OUT}” are tied together and serve as SDA. The “SDA_{IN}” pin must be connected to act as SDA. The “SDA_{OUT}” pin may be disconnected. When “SDA_{OUT}” pin is disconnected, the acknowledgement signal will be ignored in the I²C-bus.

c) I²C-bus clock signal (SCL)

The transmission of information in the I²C-bus is following a clock signal, SCL. Each transmission of data bit is taken place during a single clock period of SCL.

6.1.5.1 I²C-bus Write data

The I²C-bus interface gives access to write data and command into the device. Please refer to Figure 6-7 for the write mode of I²C-bus in chronological order.

Figure 6-7 : I²C-bus data format

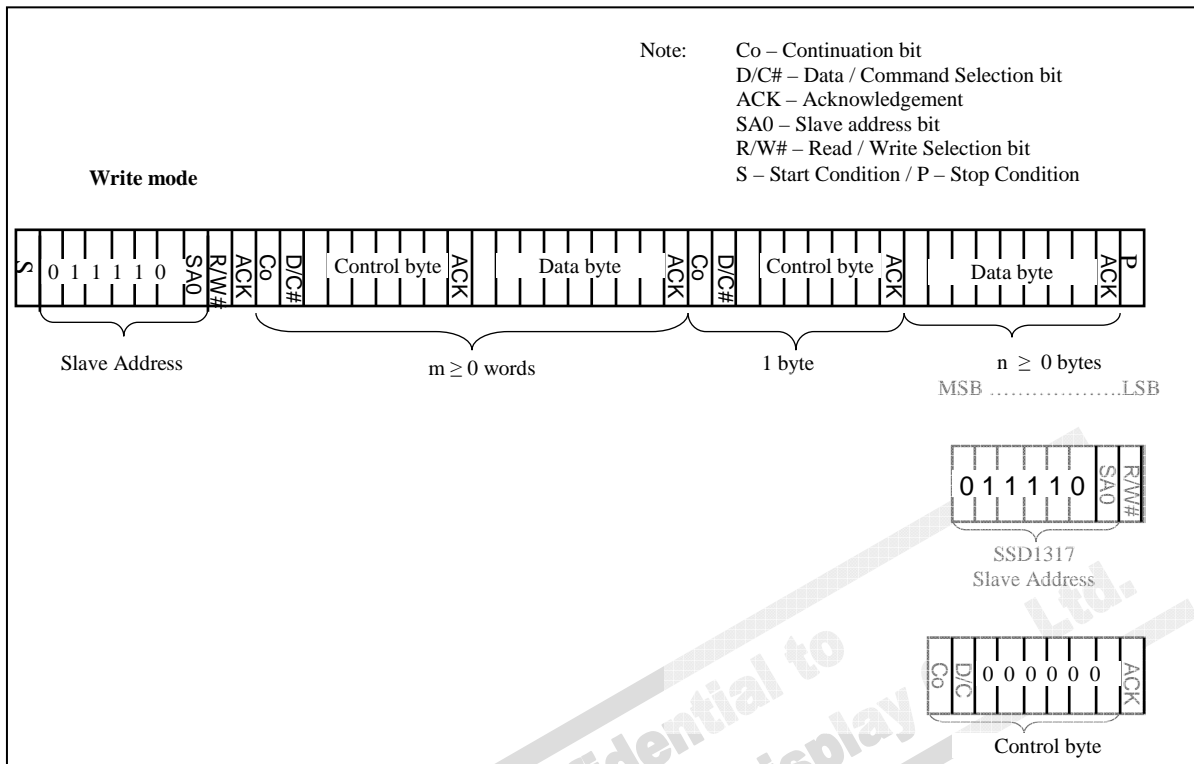

6.1.5.2 Write mode for I²C

- 1) The master device initiates the data communication by a start condition. The definition of the start condition is shown in Figure 6-8. The start condition is established by pulling the SDA from HIGH to LOW while the SCL stays HIGH.
- 2) The slave address is following the start condition for recognition use. For the SSD1317, the slave address is either “b0111100” or “b0111101” by changing the SA0 to LOW or HIGH (D/C pin acts as SA0).
- 3) The write mode is established by setting the R/W# bit to logic “0”.
- 4) An acknowledgement signal will be generated after receiving one byte of data, including the slave address and the R/W# bit. Please refer to the
- 5) Figure 6-9 for the graphical representation of the acknowledge signal. The acknowledge bit is defined as the SDA line is pulled down during the HIGH period of the acknowledgement related clock pulse.
- 6) After the transmission of the slave address, either the control byte or the data byte may be sent across the SDA. A control byte mainly consists of Co and D/C# bits following by six “0”’s.
 - a. If the Co bit is set as logic “0”, the transmission of the following information will contain data bytes only.
 - b. The D/C# bit determines the next data byte is acted as a command or a data. If the D/C# bit is set to logic “0”, it defines the following data byte as a command. If the D/C# bit is set to logic “1”, it defines the following data byte as a data which will be stored at the GDDRAM. The GDDRAM column address pointer will be increased by one automatically after each data write.
- 7) Acknowledge bit will be generated after receiving each control byte or data byte.
- 8) The write mode will be finished when a stop condition is applied. The stop condition is also defined in Figure 6-8. The stop condition is established by pulling the “SDA in” from LOW to HIGH while the “SCL” stays HIGH.

Figure 6-8 : Definition of the Start and Stop Condition

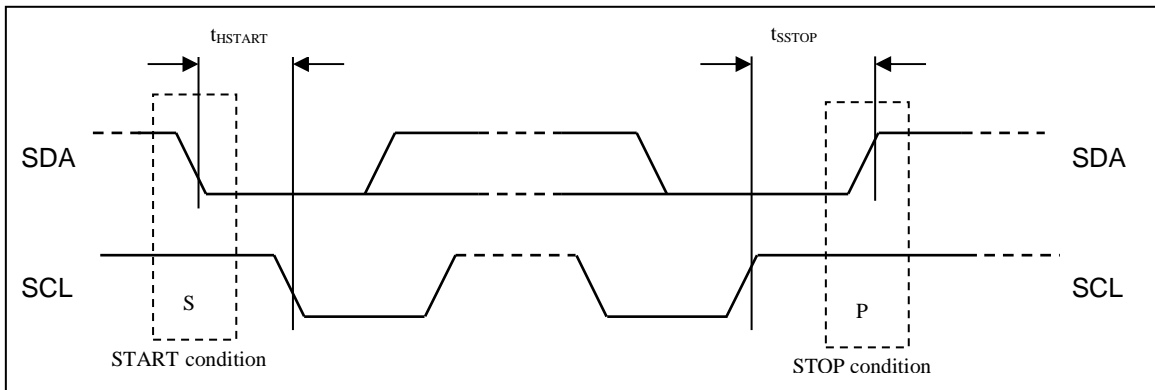
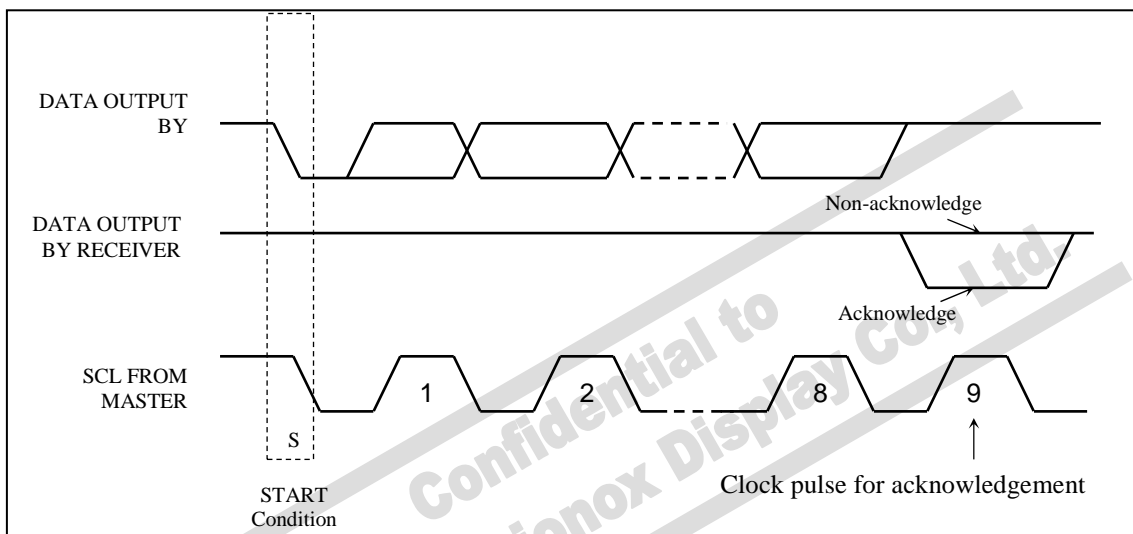

Figure 6-9 : Definition of the acknowledgement condition



Please be noted that the transmission of the data bit has some limitations.

1. The data bit, which is transmitted during each SCL pulse, must keep at a stable state within the “HIGH” period of the clock pulse. Please refer to the Figure 6-10 for graphical representations. Except in start or stop conditions, the data line can be switched only when the SCL is LOW.
2. Both the data line (SDA) and the clock line (SCL) should be pulled up by external resistors.

Figure 6-10 : Definition of the data transfer condition

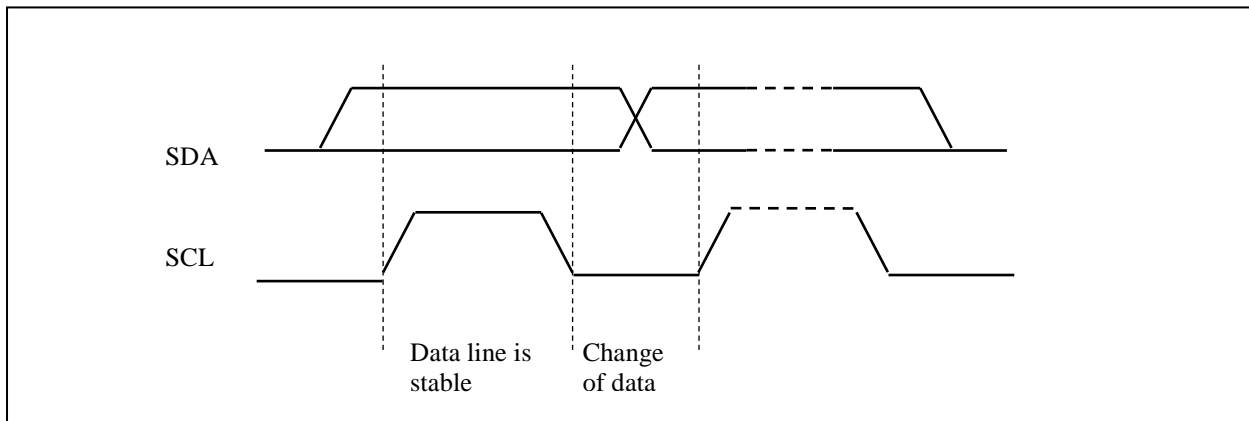

6.2 Command Decoder

This module determines whether the input data is interpreted as data or command. Data is interpreted based upon the input of the D/C# pin.

If D/C# pin is HIGH, D[7:0] is interpreted as display data written to Graphic Display Data RAM (GDDRAM). If it is LOW, the input at D[7:0] is interpreted as a command. Then data input will be decoded and written to the corresponding command register.

6.3 Oscillator Circuit and Display Time Generator

Figure 6-11 : Oscillator Circuit and Display Time Generator

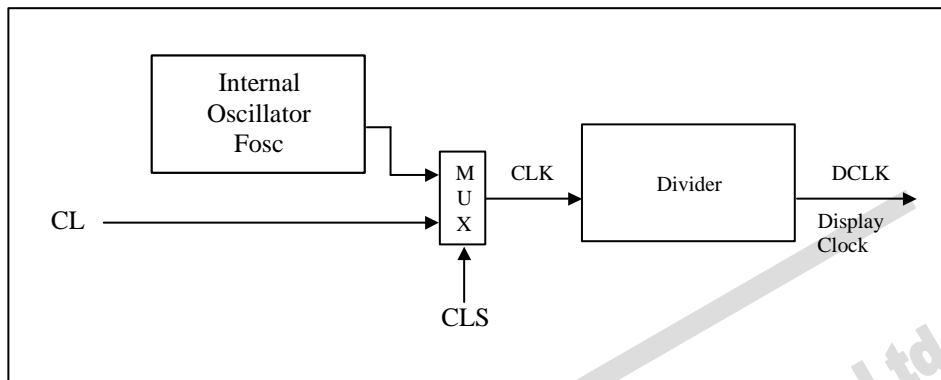

This module is an on-chip LOW power RC oscillator circuitry. The operation clock (CLK) can be generated either from internal oscillator or external source CL pin. This selection is done by CLS pin. If CLS pin is pulled HIGH, internal oscillator is chosen and CL should be connected to V_{SS}. Pulling CLS pin LOW disables internal oscillator and external clock must be connected to CL pins for proper operation. When the internal oscillator is selected, its output frequency F_{osc} can be changed by command D5h A[7:4].

The display clock (DCLK) for the Display Timing Generator is derived from CLK. The division factor “D” can be programmed from 1 to 256 by command D5h

$$DCLK = F_{osc} / D$$

The frame frequency of display is determined by the following formula.

$$F_{FRM} = \frac{F_{osc}}{D \times K \times \text{No. of Mux}}$$

where

- D stands for clock divide ratio. It is set by command D5h A[3:0]. The divide ratio has the range from 1 to 256.
- K is the number of display clocks per row. The value is derived by
 $K = \text{Phase 1 period} + \text{Phase 2 period} + K_0$
 $= 2 + 2 + 69 = 73$ at power on reset (that is K₀ is a constant that equals to 69)
 Please refer to Section 6.5 “Segment Drivers / Common Drivers” for the details of the “Phase”.
- Number of multiplex ratio is set by command A8h. The power on reset value is 95 (i.e. 96MUX).
- F_{osc} is the oscillator frequency. It can be changed by command D5h A[7:4]. The higher the register setting results in higher frequency.

6.4 Reset Circuit

When RES# input is LOW, the chip is initialized with the following status:

1. Display is OFF
2. 128 x 96 Display Mode
3. Normal segment and display data column address and row address mapping (SEG0 mapped to address 00h and COM0 mapped to address 00h)
4. Shift register data clear in serial interface
5. Display start line is set at display RAM address 0
6. Column address counter is set at 0
7. Normal scan direction of the COM outputs
8. Contrast control register is set at 7Fh
9. Normal display mode (Equivalent to A4h command)

6.5 Segment Drivers / Common Drivers

Segment drivers deliver 128 current sources to drive the OLED panel. The driving current can be adjusted by altering the registers of the contrast setting command (81h). Common drivers generate voltage-scanning pulses.

The segment driving waveform is divided into three phases:

1. In phase 1, the OLED pixel charges of previous image are discharged in order to prepare for next image content display.
2. In phase 2, the OLED pixel is driven to the targeted voltage. The pixel is driven to attain the corresponding voltage level from V_{SS} . The period of phase 2 can be programmed in length from 1 to 15 DCLKs. If the capacitance value of the pixel of OLED panel is larger, a longer period is required to charge up the capacitor to reach the desired voltage.
3. In phase 3, the OLED driver switches to use current source to drive the OLED pixels and this is the current drive stage.

Figure 6-12 : Segment Output Waveform in three phases

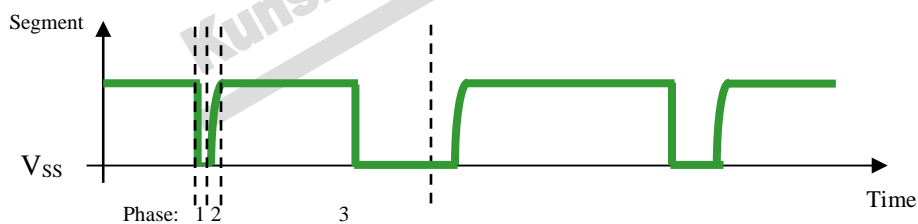

After finishing phase 3, the driver IC will go back to phase 1 to display the next row image data. This three-step cycle is run continuously to refresh image display on OLED panel.

In phase 3, if the length of current drive pulse width is set to 69, after finishing 69 DCLKs in current drive phase, the driver IC will go back to phase 1 for next row display.

6.6 Graphic Display Data RAM (GDDRAM)

The GDDRAM is a bit mapped static RAM holding the bit pattern to be displayed. The size of the RAM is 128 x 96 bits and the RAM is divided into eight pages, from PAGE0 to PAGE11, which are used for monochrome 128x96 dot matrix display, as shown in Figure 6-13.

Figure 6-13 : GDDRAM pages structure

		Row re-mapping
PAGE0 (COM0-COM7)	Page 0	PAGE0 (COM95-COM88)
PAGE1 (COM8-COM15)	Page 1	PAGE1 (COM87-COM80)
PAGE2 (COM16-COM23)	Page 2	PAGE2 (COM79-COM72)
PAGE3 (COM24-COM31)	Page 3	PAGE3 (COM71-COM64)
PAGE4 (COM32-COM39)	Page 4	PAGE4 (COM63-COM56)
PAGE5 (COM40-COM47)	Page 5	PAGE5 (COM55-COM48)
PAGE6 (COM48-COM55)	Page 6	PAGE6 (COM47-COM40)
PAGE7 (COM56-COM63)	Page 7	PAGE7 (COM39-COM32)
PAGE8 (COM64-COM71)	Page 8	PAGE8 (COM31-COM24)
PAGE9 (COM72-COM79)	Page 9	PAGE9 (COM23-COM16)
PAGE10 (COM80-COM87)	Page 10	PAGE10 (COM15-COM8)
PAGE11 (COM88-COM95)	Page 11	PAGE11 (COM 7-COM0)
	SEG0 -----SEG127	
Column re-mapping	SEG127 -----SEG0	

When one data byte is written into GDDRAM, all the rows image data of the same page of the current column are filled (i.e. the whole column (8 bits) pointed by the column address pointer is filled.). Data bit D0 is written into the top row, while data bit D7 is written into bottom row as shown in Figure 6-14.

Figure 6-14 : Enlargement of GDDRAM (No row re-mapping and column-remapping)

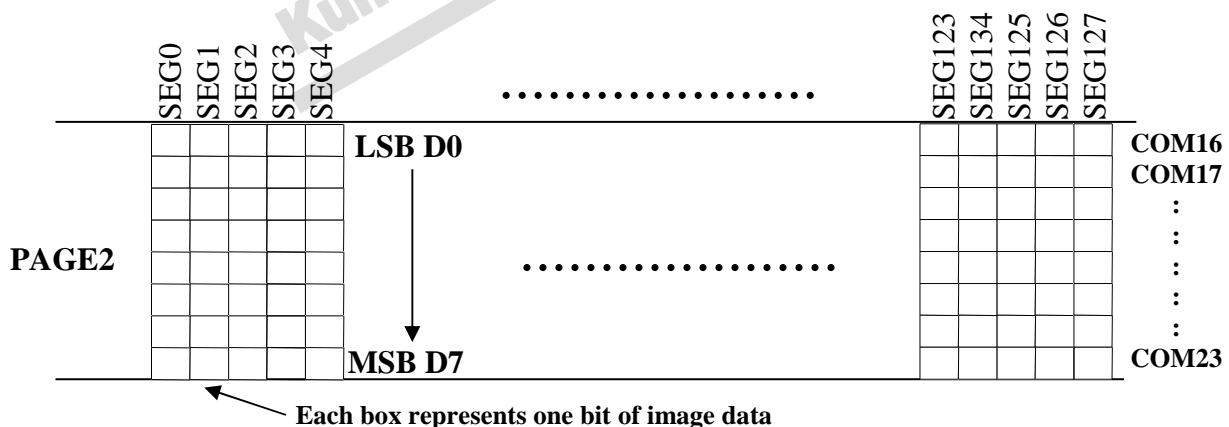

For mechanical flexibility, re-mapping on both Segment and Common outputs can be selected by software as shown in Figure 6-13.

For vertical shifting of the display, an internal register storing the display start line can be set to control the portion of the RAM data to be mapped to the display (command D3h).

6.7 SEG/COM Driving block

This block is used to derive the incoming power sources into the different levels of internal use voltage and current.

- V_{CC} is the most positive voltage supply.
- V_{COMH} is the Common deselected level. It is internally regulated.
- V_{LSS} is the ground path of the analog and panel current.
- I_{REF} is a reference current source for segment current drivers I_{SEG} . The relationship between reference current and segment current of a color is:

$$I_{SEG} = \text{Contrast} / 8 \times I_{REF}$$

in which the contrast (1~255) is set by Set Contrast command 81h

When internal I_{REF} is used, the I_{REF} pin should be kept NC.

Bit A[4] of command ADh is used to select external or internal I_{REF} :

A[4] = '0' Select external I_{REF} [Reset]

A[4] = '1' Enable internal I_{REF} during display ON

When external I_{REF} is used, the magnitude of I_{REF} is controlled by the value of resistor, which is connected between I_{REF} pin and V_{SS} as shown in Figure 6-15. It is recommended to set I_{REF} to $18.75 \pm 2\mu\text{A}$ so as to achieve $I_{SEG} = 600\mu\text{A}$ at maximum contrast 255.

Figure 6-15 : I_{REF} Current Setting by Resistor Value

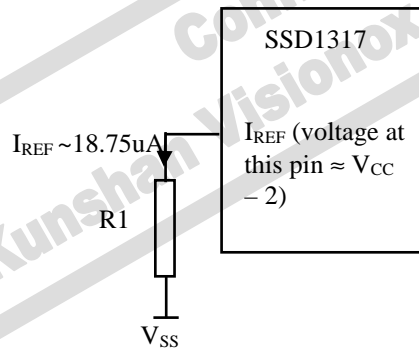

Since the voltage at I_{REF} pin is $V_{CC} - 2V$, the value of resistor $R1$ can be found as below:

For $I_{REF} = 18.75\mu\text{A}$, $V_{CC} = 12V$:

$$\begin{aligned} R1 &= (\text{Voltage at } I_{REF} - V_{SS}) / I_{REF} \\ &\approx (12 - 2) / 18.75\mu\text{A} \\ &= 530\text{k}\Omega \end{aligned}$$

6.8 Power ON and OFF sequence

The following figures illustrate the recommended power ON and power OFF sequence of SSD1317.

Power ON sequence:

1. Power ON V_{DD}
2. After V_{DD} become stable, wait at least 20ms (t_0), set RES# pin LOW (logic low) for at least 3 μ s (t_1)⁽⁴⁾ and then HIGH (logic high).
3. After set RES# pin LOW (logic low), wait for at least 3 μ s (t_2). Then Power ON V_{CC} .⁽¹⁾
1. After V_{CC} become stable, send command AFh for display ON. SEG/COM will be ON after 100ms (t_{AF}).

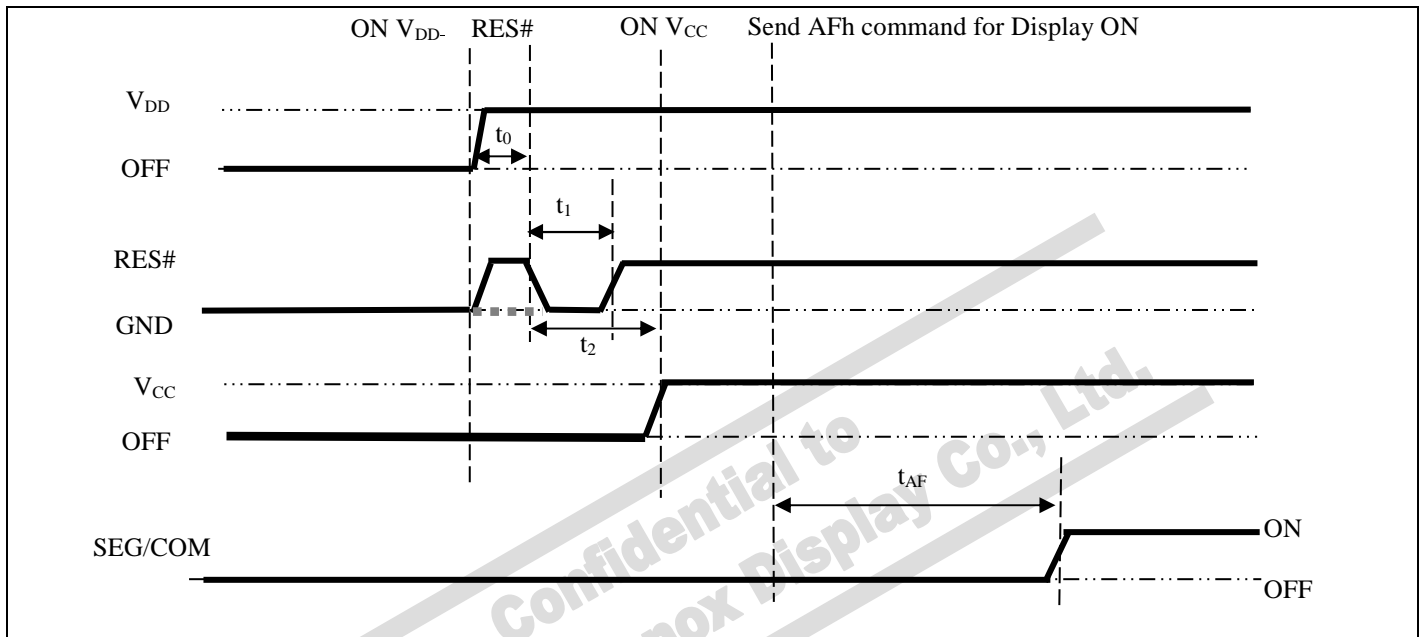
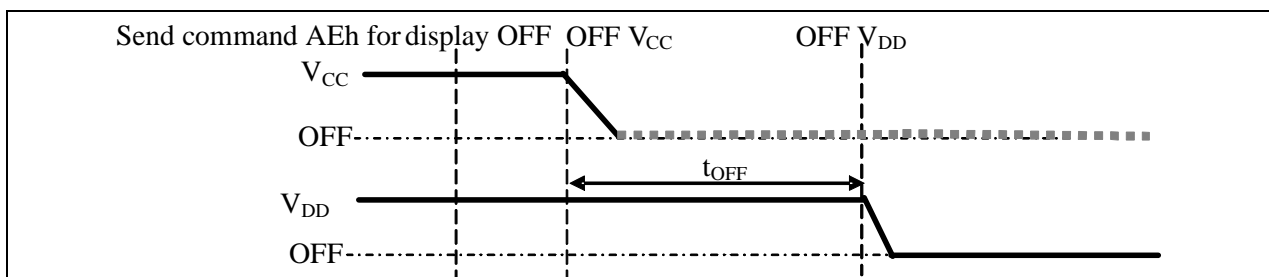

Figure 6-16 : The Power ON sequence

Power OFF sequence:

1. Send command AEh for display OFF.
2. Power OFF V_{CC} .^{(1), (2)}
3. Power OFF V_{DD} after t_{OFF} .⁽⁴⁾ (where Minimum t_{OFF} =0ms, typical t_{OFF} =100ms)

Figure 6-17 : The Power OFF sequence



Note:

- ⁽¹⁾ V_{CC} should be kept float (i.e. disable) when it is OFF.
- ⁽²⁾ Power Pins (V_{DD} , V_{CC}) can never be pulled to ground under any circumstance.
- ⁽³⁾ The register values are reset after t_1 .
- ⁽⁴⁾ V_{DD} should not be Power OFF before V_{CC} Power OFF.

7 MAXIMUM RATINGS

Table 7-1 : Maximum Ratings

(Voltage Reference to V_{SS})

Symbol	Parameter	Value	Unit
V_{DD}	Supply Voltage	-0.3 to +4	V
V_{CC}		0 to 17	V
V_{SEG}	SEG output voltage	0 to V_{CC}	V
V_{COM}	COM output voltage	0 to $0.9 \cdot V_{CC}$	V
V_{in}	Input voltage	$V_{SS}-0.3$ to $V_{DD}+0.3$	V
T_A	Operating Temperature	-40 to +85	°C
T_{stg}	Storage Temperature Range	-65 to +150	°C

*Maximum Ratings are those values beyond which damage to the device may occur. Functional operation should be restricted to the limits in the Electrical Characteristics tables or Pin Description.

*This device may be light sensitive. Caution should be taken to avoid exposure of this device to any light source during normal operation. This device is not radiation protected.

Confidential to
Kunshan Visionox Display Co., Ltd.

8 DC CHARACTERISTICS

Condition (Unless otherwise specified):

Voltage referenced to V_{SS}

$V_{DD} = 1.65V$ to $3.3V$

$T_A = 25^\circ C$

Table 8-1 : DC Characteristics

Symbol	Parameter	Test Condition	Min	Typ	Max	Unit
V_{CC}	Operating Voltage	-	7	-	16.5	V
V_{DD}	Logic Supply Voltage	-	1.65	-	3.3	V
V_{OH}	High Logic Output Level	$I_{OUT} = 100\mu A, 3.3MHz$	$0.9 \times V_{DD}$	-	-	V
V_{OL}	Low Logic Output Level	$I_{OUT} = 100\mu A, 3.3MHz$	-	-	$0.1 \times V_{DD}$	V
V_{IH}	High Logic Input Level	-	$0.8 \times V_{DD}$	-	-	V
V_{IL}	Low Logic Input Level	-	-	-	$0.2 \times V_{DD}$	V
$I_{DD,SLEEP}$	Sleep mode Current	$V_{DD} = 1.65V \sim 3.3V, V_{CC} = 7V \sim 16.5V$ Display OFF, No panel attached	-	-	10	μA
$I_{CC,SLEEP}$	Sleep mode Current	$V_{DD} = 1.65V \sim 3.3V, V_{CC} = 7V \sim 16.5V$ Display OFF, No panel attached	-	-	10	μA
I_{CC}	V_{CC} Supply Current $V_{DD} = 2.8V, V_{CC} = 12V,$ $I_{REF} = 18.75\mu A,$ No loading, Display ON, All ON	Contrast = FFh	-	800	1100	μA
I_{DD}	V_{DD} Supply Current $V_{DD} = 2.8V, V_{CC} = 12V,$ $I_{REF} = 18.75\mu A,$ No loading, Display ON, All ON,		-	220	300	μA
I_{SEG}	Segment Output Current, $V_{DD} = 2.8V, V_{CC} = 12V,$ $I_{REF} = 18.75\mu A,$ Display ON.	Contrast=FFh	540	600	660	μA
		Contrast=7Fh	-	300	-	
		Contrast=3Fh	-	150	-	
Dev	Segment output current uniformity	$Dev = (I_{SEG} - I_{MID}) / I_{MID}$ $I_{MID} = (I_{MAX} + I_{MIN}) / 2$ $I_{SEG}[0:127] =$ Segment current at contrast setting = FFh	-3	-	3	%
Adj. Dev	Adjacent pin output current uniformity (contrast setting = FFh)	$Adj\ Dev = (I[n] - I[n+1]) / (I[n] + I[n+1])$	-2	-	2	%

9 AC CHARACTERISTICS

Conditions:

Voltage referenced to V_{SS}

$V_{DD}=1.65$ to $3.3V$

$T_A = 25^{\circ}C$

Table 9-1 : AC Characteristics

Symbol	Parameter	Test Condition	Min	Typ	Max	Unit
$F_{OSC}^{(1)}$	Oscillation Frequency of Display Timing Generator	$V_{DD} = 2.8V$	720	800	880	kHz
F_{FRM}	Frame Frequency	128x96 Graphic Display Mode, Display ON, Internal Oscillator Enabled	-	$F_{OSC} \times 1/(D \times K \times 96)^{(2)}$	-	Hz
RES#	Reset low pulse width		3	-	-	us

Note

⁽¹⁾ F_{OSC} stands for the frequency value of the internal oscillator and the value is measured when command D5h A[7:4] is in default value.

⁽²⁾ D: divide ratio (default value = 1)

K: number of display clocks per row period (default value = 73)

Confidential to
Kunshan Visionox Display Co., Ltd.

Table 9-2 : 6800-Series MCU Parallel Interface Timing Characteristics

($V_{DD} - V_{SS} = 1.65V$ to $3.3V$, $T_A = 25^\circ C$)

Symbol	Parameter	Min	Typ	Max	Unit
t_{cycle}	Clock Cycle Time	300	-	-	ns
t_{AS}	Address Setup Time	20	-	-	ns
t_{AH}	Address Hold Time	0	-	-	ns
t_{DSW}	Write Data Setup Time	40	-	-	ns
t_{DHW}	Write Data Hold Time	40	-	-	ns
t_{DHR}	Read Data Hold Time	20	-	-	ns
t_{OH}	Output Disable Time	-	-	70	ns
t_{ACC}	Access Time	-	-	150	ns
PW_{CSL}	Chip Select Low Pulse Width (read) Chip Select Low Pulse Width (write)	150 60	-	-	ns
PW_{CSH}	Chip Select High Pulse Width (read) Chip Select High Pulse Width (write)	60 100	-	-	ns
t_R	Rise Time	-	-	40	ns
t_F	Fall Time	-	-	40	ns

Figure 9-1 : 6800-series MCU parallel interface characteristics

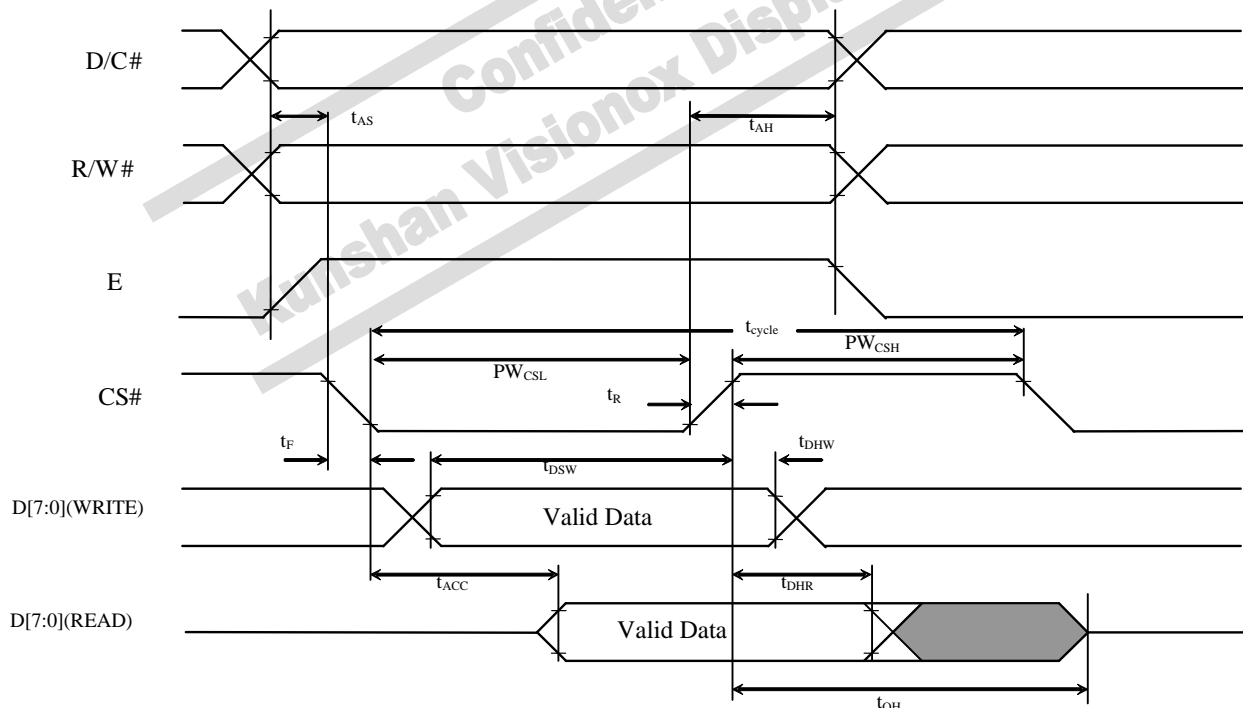
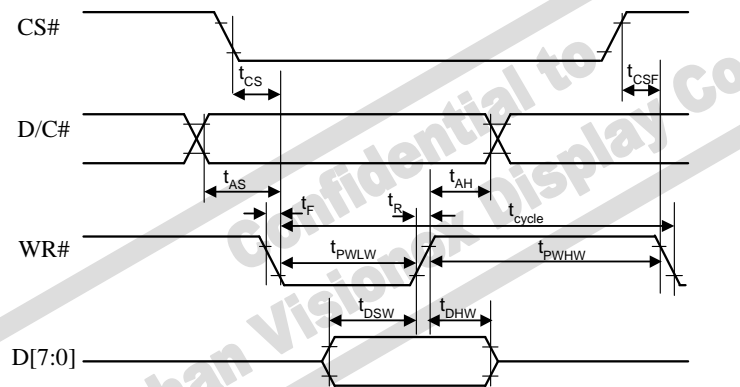

Table 9-3 : 8080-Series MCU Parallel Interface Timing Characteristics

($V_{DD} - V_{SS} = 1.65V \sim 3.3V$, $T_A = 25^\circ C$)

Symbol	Parameter	Min	Typ	Max	Unit
t_{cycle}	Clock Cycle Time	300	-	-	ns
t_{AS}	Address Setup Time	20	-	-	ns
t_{AH}	Address Hold Time	0	-	-	ns
t_{DSW}	Write Data Setup Time	40	-	-	ns
t_{DHW}	Write Data Hold Time	40	-	-	ns
t_{DHR}	Read Data Hold Time	20	-	-	ns
t_{OH}	Output Disable Time	-	-	70	ns
t_{ACC}	Access Time	-	-	150	ns
t_{PWLR}	Read Low Time	150	-	-	ns
t_{PWLW}	Write Low Time	60	-	-	ns
t_{PWHR}	Read High Time	60	-	-	ns
t_{PWHW}	Write High Time	100	-	-	ns
t_R	Rise Time	-	-	40	ns
t_F	Fall Time	-	-	40	ns
t_{CS}	Chip select setup time	0	-	-	ns
t_{CSH}	Chip select hold time to read signal	0	-	-	ns
t_{CSF}	Chip select hold time	20	-	-	ns

Figure 9-2 : 8080-series parallel interface characteristics



Write cycle

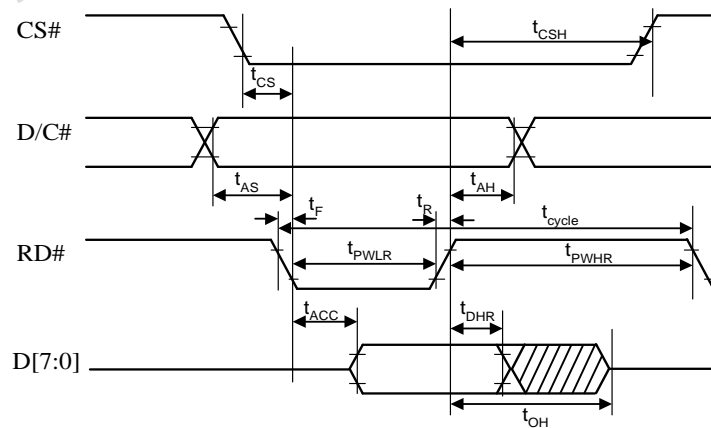

Read Cycle

Table 9-4 : Serial Interface Timing Characteristics (4-wire SPI)

($V_{DD} - V_{SS} = 1.65V \sim 3.3V$, $T_A = 25^\circ C$)

Symbol	Parameter	Min	Typ	Max	Unit
t_{cycle}	Clock Cycle Time	100	-	-	ns
t_{AS}	Address Setup Time	15	-	-	ns
t_{AH}	Address Hold Time	15	-	-	ns
t_{CSS}	Chip Select Setup Time	20	-	-	ns
t_{CSH}	Chip Select Hold Time	50	-	-	ns
t_{DSW}	Write Data Setup Time	20	-	-	ns
t_{DHW}	Write Data Hold Time	20	-	-	ns
t_{CLKL}	Clock Low Time	50	-	-	ns
t_{CLKH}	Clock High Time	50	-	-	ns
t_R	Rise Time	-	-	40	ns
t_F	Fall Time	-	-	40	ns

Figure 9-3 : Serial interface characteristics (4-wire SPI)

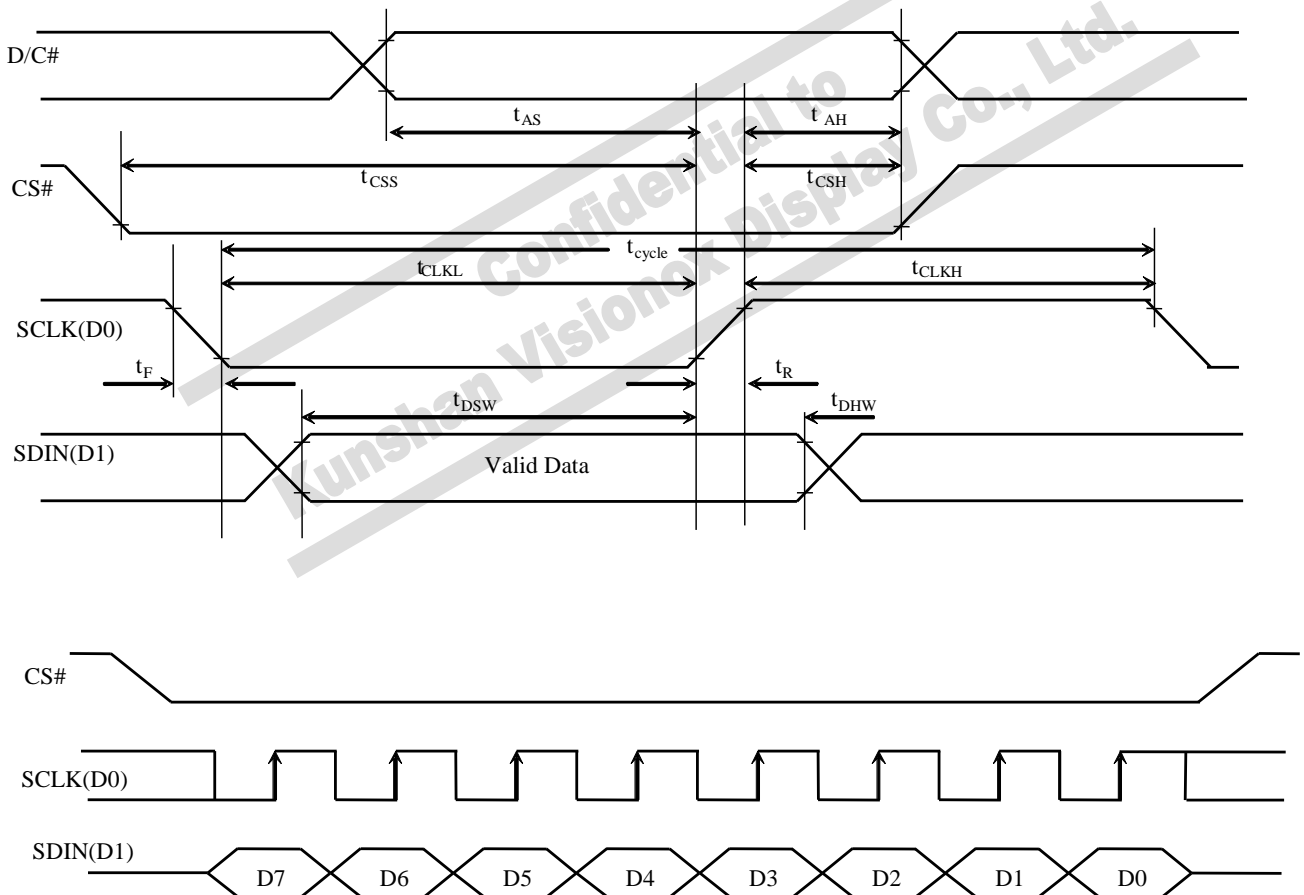

Table 9-5 : Serial Interface Timing Characteristics (3-wire SPI)

($V_{DD} - V_{SS} = 1.65V \sim 3.3V$, $T_A = 25^\circ C$)

Symbol	Parameter	Min	Typ	Max	Unit
t_{cycle}	Clock Cycle Time	100	-	-	ns
t_{CSS}	Chip Select Setup Time	20	-	-	ns
t_{CSH}	Chip Select Hold Time	50	-	-	ns
t_{DSW}	Write Data Setup Time	20	-	-	ns
t_{DHW}	Write Data Hold Time	20	-	-	ns
t_{CLKL}	Clock Low Time	50	-	-	ns
t_{CLKH}	Clock High Time	50	-	-	ns
t_R	Rise Time	-	-	40	ns
t_F	Fall Time	-	-	40	ns

Figure 9-4 : Serial interface characteristics (3-wire SPI)

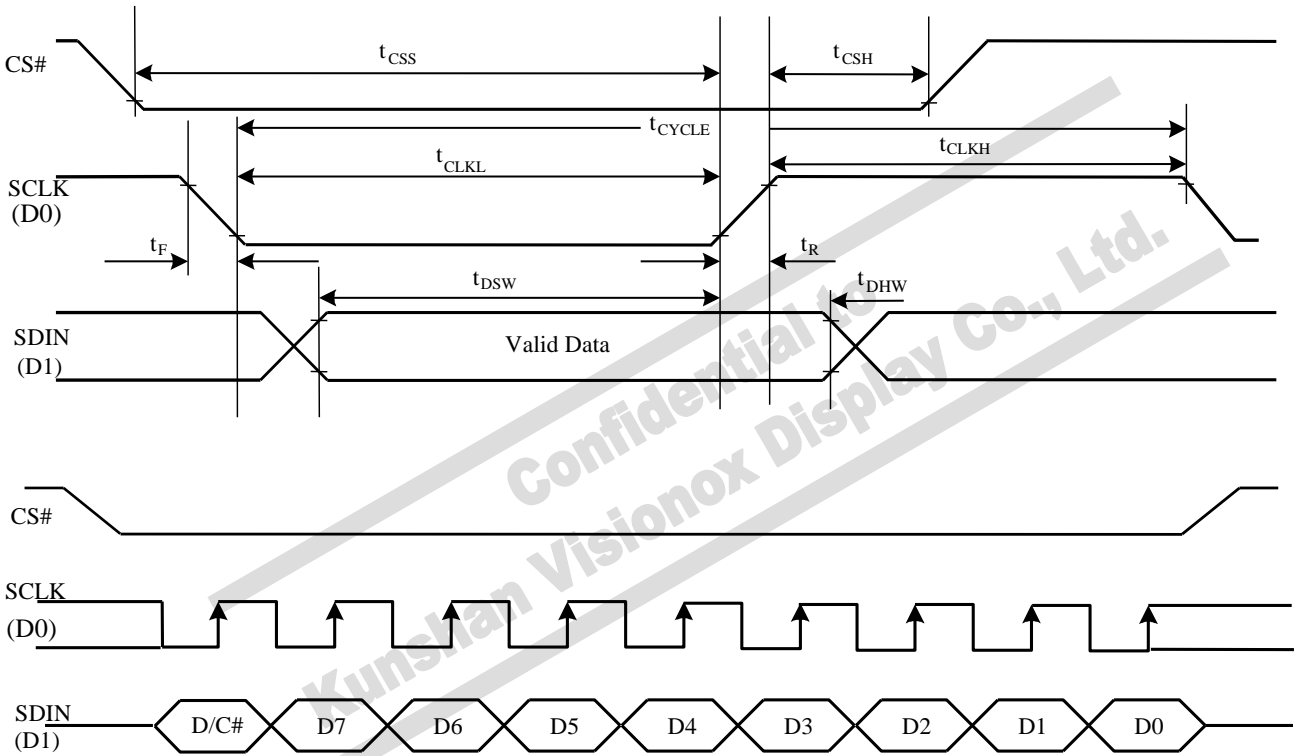
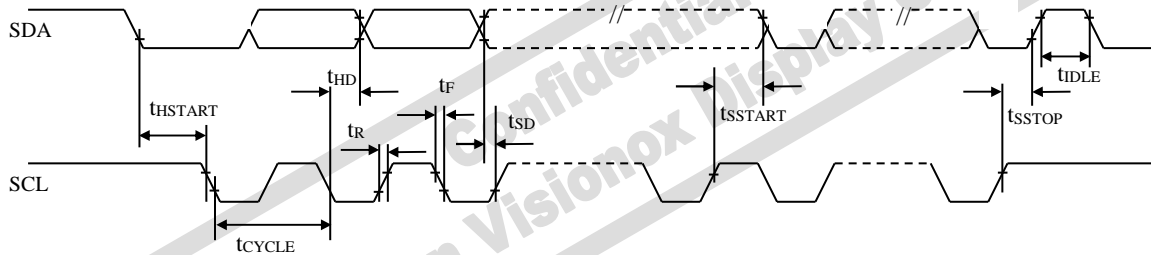

Table 9-6 : I²C Interface Timing Characteristics

(V_{DD} - V_{SS} = 1.65V~3.3V, T_A = 25°C)

Symbol	Parameter	Min	Typ	Max	Unit
t _{cycle}	Clock Cycle Time	2.5	-	-	us
t _{HSTART}	Start condition Hold Time	0.6	-	-	us
t _{HD}	Data Hold Time (for “SDA _{OUT} ” pin)	0	-	-	ns
	Data Hold Time (for “SDA _{IN} ” pin)	300	-	-	ns
t _{SD}	Data Setup Time	100	-	-	ns
t _{SSTART}	Start condition Setup Time (Only relevant for a repeated Start condition)	0.6	-	-	us
t _{SSTOP}	Stop condition Setup Time	0.6	-	-	us
t _R	Rise Time for data and clock pin	-	-	300	ns
t _F	Fall Time for data and clock pin	-	-	300	ns
t _{IDLE}	Idle Time before a new transmission can start	1.3	-	-	us

Figure 9-5 : I²C interface Timing characteristics



10 APPLICATION EXAMPLE

Figure 10-1 : Application Example of SSD1317Z

The configuration for I²C interface mode is shown in the following diagram:
(V_{DD}=2.8V, V_{CC}=12V, I_{REF}=18.75uA)

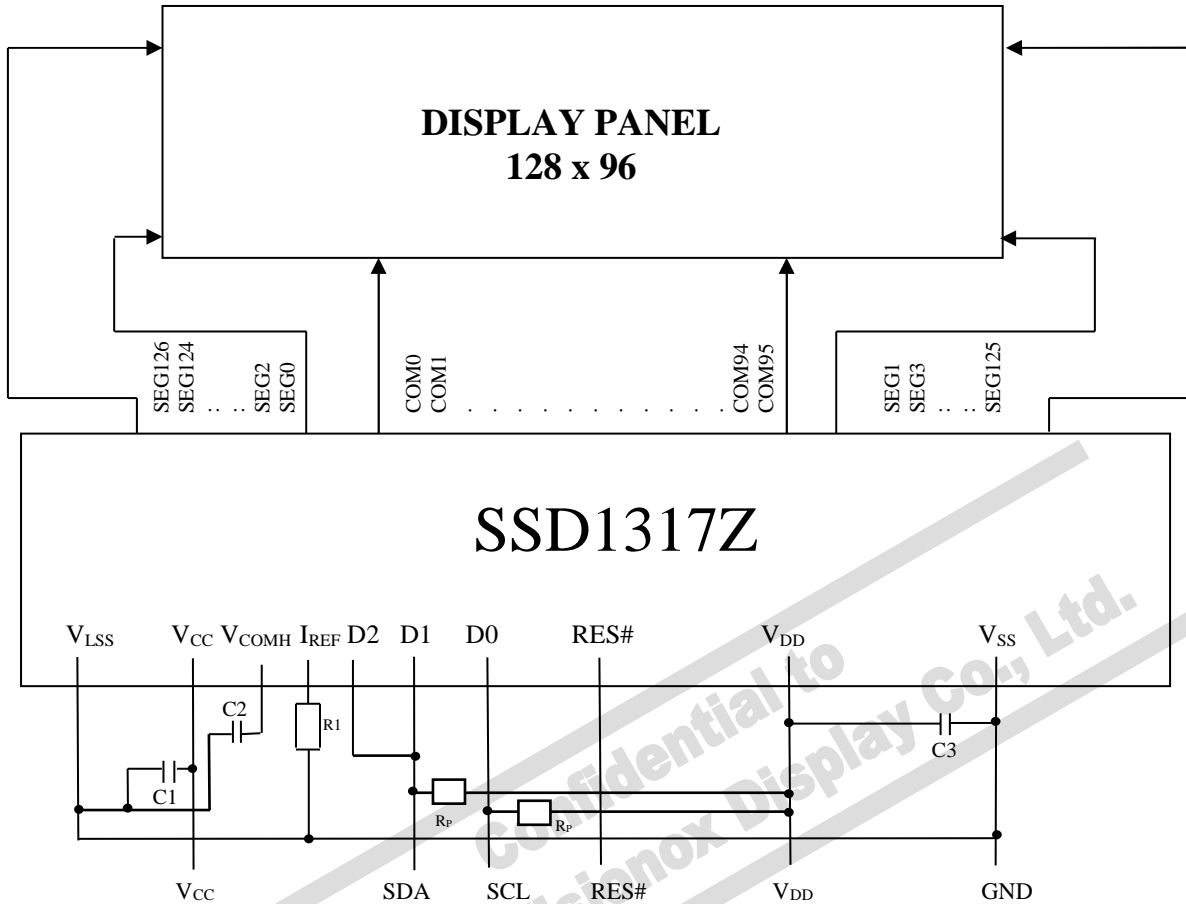

Pin connected to MCU interface: D[2:0], RES#
 Pin internally connected to V_{LSS}: BGGND, VSL
 Pin internally connected to V_{SS} (or V_{LL}): D[7:3], BS0, BS2, E, R/W#, CS#, CL
 Pin internally connected to V_{DD} (or V_{LL}): BS1, CLS
 Pin internally connected to V_{CC}: V_{CC1}
 VBREF, FR, T0, T1, TR[10:0] should be left open
 D/C# acts as SA0 for slave address selection

C1, C2: 2.2uF⁽¹⁾
 C3: 1.0uF⁽¹⁾ place close to IC V_{DD} and V_{SS} pins on PCB
 R_p : Pull up resistor

Voltage at I_{REF} = V_{CC} - 2V. For V_{CC} = 12V, I_{REF} = 18.75uA:
 $R1 = (\text{Voltage at } I_{REF} - V_{SS}) / I_{REF}$
 $\approx (12-2)V / 18.75\mu A$
 $\approx 530K\Omega$

Note

- (1) The capacitor value is recommended value. Select appropriate value against module application.
- (2) Die gold bump face down.
- (3) V_{LSS} of IC pad no. 25 to 29 are recommended to be connected to the V_{LSS} of pad no. 65 to 68 to form a larger area of GND.
- (4) V_{LSS} and V_{SS} are not recommended to be connected on the ITO routing, but connected together in the PCB level at one common ground point for better grounding and noise insulation.

Confidential to
Shenzhen Visionox Display Co., Ltd.

Solomon Systech reserves the right to make changes without notice to any products herein. Solomon Systech makes no warranty, representation or guarantee regarding the suitability of its products for any particular purpose, nor does Solomon Systech assume any liability arising out of the application or use of any product or circuit, and specifically disclaims any, and all, liability, including without limitation consequential or incidental damages. "Typical" parameters can and do vary in different applications. All operating parameters, including "Typical" must be validated for each customer application by the customer's technical experts. Solomon Systech does not convey any license under its patent rights nor the rights of others. Solomon Systech products are not designed, intended, or authorized for use as components in systems intended for surgical implant into the body, or other applications intended to support or sustain life, or for any other application in which the failure of the Solomon Systech product could create a situation where personal injury or death may occur. Should Buyer purchase or use Solomon Systech products for any such unintended or unauthorized application, Buyer shall indemnify and hold Solomon Systech and its offices, employees, subsidiaries, affiliates, and distributors harmless against all claims, costs, damages, and expenses, and reasonable attorney fees arising out of, directly or indirectly, any claim of personal injury or death associated with such unintended or unauthorized use, even if such claim alleges that Solomon Systech was negligent regarding the design or manufacture of the part.



The product(s) listed in this datasheet comply with Directive 2011/65/EU of the European Parliament and of the council of 8 June 2011 on the restriction of the use of certain hazardous substances in electrical and electronic equipment and People's Republic of China Electronic Industry Standard SJ/T 11363-2006 "Requirements for concentration limits for certain hazardous substances in electronic information products (电子信息产品中有毒有害物质的限量要求)". Hazardous Substances test report is available upon request.

With collaboration of <https://www.displayfuture.com>