



DATA SHEET

SCN6400G 64-Common Dot-matrix STN LCD Driver

To improve design and/or performance,
Avant Electronics may make changes to its
products. Please contact Avant Electronics
for the latest versions of its products

64-Common Dot-matrix STN LCD Driver

1 GENERAL**1.1 Description**

The SCN6400G is a 64-common dot-matrix STN LCD driver. It is designed to be paired with the SCN0080G_A or the SCN0080G_B 80-segment driver.

1.2 Features

- 64-output common driver for dot-matrix STN LCD.
- Display duty cycle: 1/64 to 1/128
- Display-off mode for reducing power consumption.
- 4-level external LCD bias voltage.
- Capability of being cascaded to expand common number.
- 64-bit bi-directional shift register: right shift or left shift.
- Operating voltage range (control logic): 2.7 ~ 5.5 volts.
- LCD driver voltage range (LCD bias voltage, $V_{DD}-V_{EE}$): 8 ~ 20 volts.
- Data transfer clock: 6.0 MHz, when $V_{DD}= 5$ volts.
- Operating temperature range: -20 to +85 °C.
- Storage temperature range: -40 to +125 °C.

1.3 Ordering information**Table 1** Ordering information

TYPE NUMBER	DESCRIPTION
SCN6400G-LQFPG	LQFP80 Green package.
SCN6400G-QFPG	QFP80 Green package.
SCN6400G-LQFP	LQFP80 package.
SCN6400G-QFP	QFP80 package.
SCN6400G-D	tested die.

64-Common Dot-matrix STN LCD Driver

2 FUNCTIONAL BLOCK DIAGRAM AND DESCRIPTION

2.1 Functional block diagram

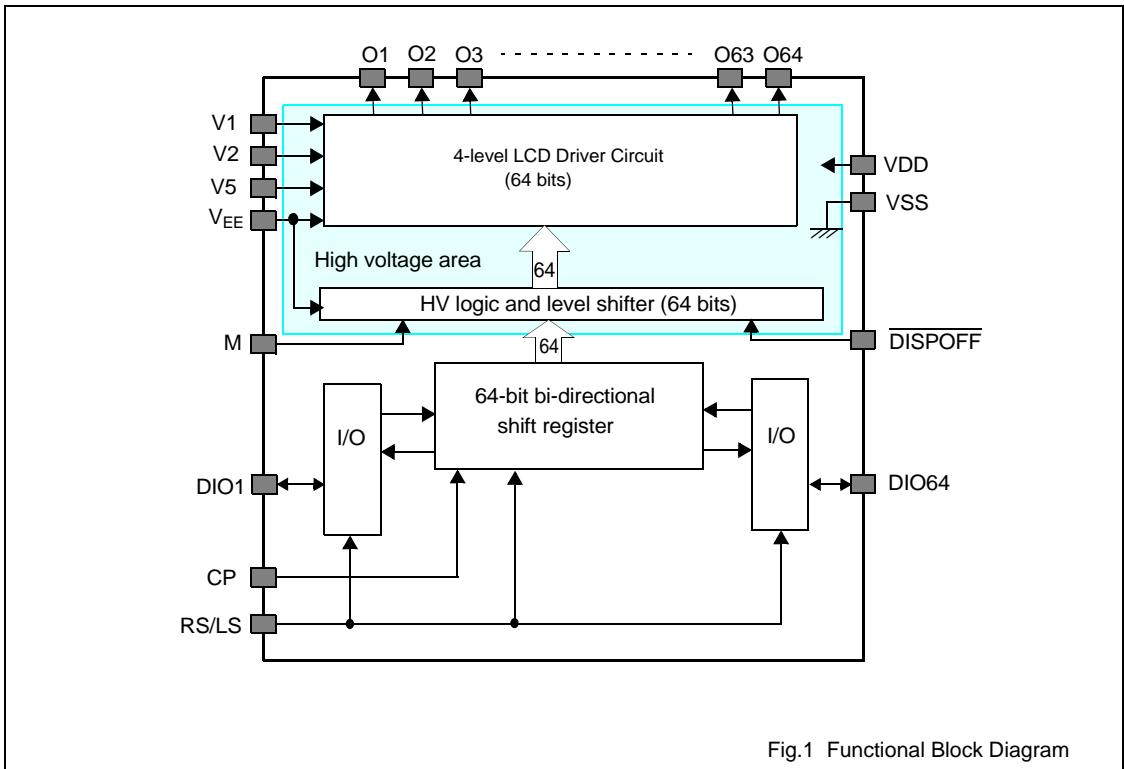

64-Common Dot-matrix STN LCD Driver

3 PINNING INFORMATION

3.1 Pinning diagram

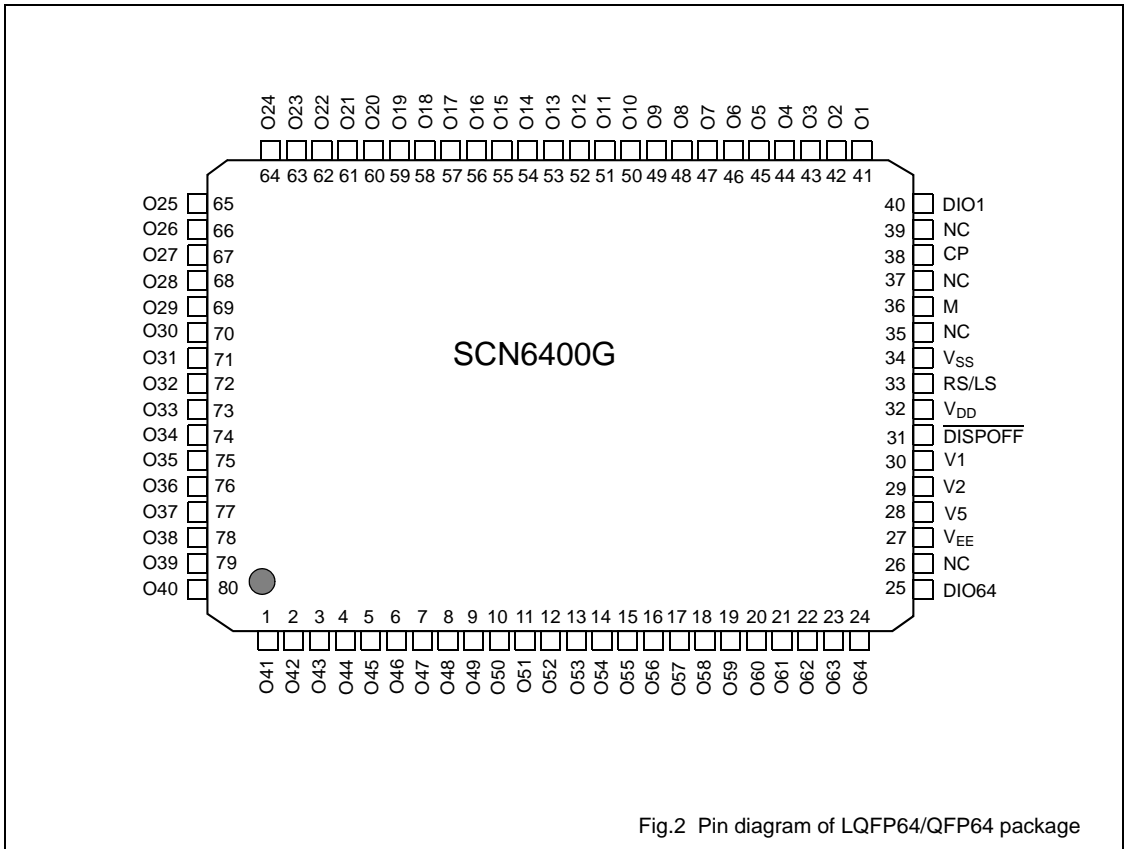

Fig.2 Pin diagram of LQFP64/QFP64 package

64-Common Dot-matrix STN LCD Driver

3.2 Signal description

Table 2 Pin signal description.

To avoid a latch-up effect at power-on: $V_{SS} - 0.5\text{ V} < \text{voltage at any pin at any time} < V_{DD} + 0.5\text{ V}$.

Pin number	SYMBOL	I/O	DESCRIPTION
41~80, 1~24	O1~O64	Output	Common driver output. Please refer to Table 3 for output voltage level and Section 9, Pin circuits, for the circuits.
26, 35, 37, 39	NC	Input	No Connection. These pins are not used in application and should be left open.
25	DIO64	I/O	Data input/output pin for cascading application.
27, 28, 29, 30	V_{EE} , V5, V2, V1	Input	LCD bias voltage. V1 and V_{EE} are selected levels. V2 and V5 are unselected levels.
31	$\overline{\text{DISPOFF}}$	Input	Display OFF for reducing power consumption. When $\overline{\text{DISPOFF}}=\text{L}$, the outputs O1~O64 are all at a fixed voltage level of V1.
32	VDD	Input	Power supply for control logic.
33	RS/LS	Input	Shift direction control for scan data reception from a controller. When RS/LS=LOW, shift direction is from left to right (right shift). When RS/LS=HIGH, shift direction is from right to left (left shift). Please refer to Table 4, Mode selection.
34	VSS	Input	Ground.
36	M	Input	Frame signal, for alternating LCD bias voltage.
38	CP	Input	Scan data latch clock.
40	DIO1	I/O	Data input/output pin for cascading application.

64-Common Dot-matrix STN LCD Driver

4 FUNCTIONAL DESCRIPTION

4.1 Common output drive (O1-O64)

The voltage level of the outputs O1-O64 is determined by input data (scan data), M (frame signal), and $\overline{\text{DISPOFF}}$, as given in the following table.

Table 3 output voltage level of O1-O64

M	Data	$\overline{\text{DISPOFF}}$	Output
L	L	H	V2
L	H	H	V _{EE}
H	L	H	V5
H	H	H	V1
X	X	L	V1

In the above table, X= don't care and must be tied either to H or L.

4.2 Mode selection

The mode selection and scan data shift direction is given in the following table.

Table 4 Mode selection

RS/LS pin	Data transfer direction	DIO1	DIO64
LOW	O1 → O64 (right shift)	IN	OUT
HIGH	O64 → O1 (left shift)	OUT	IN

Note: X= don't care. It can be tied either to VDD or to VSS.

4.3 Cascading connection

4.3.1 RIGHT SHIFT

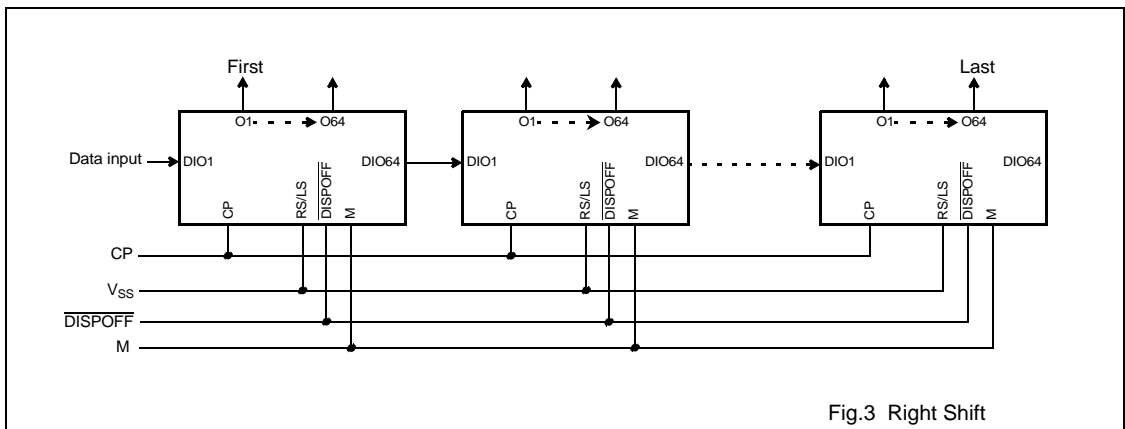

Fig.3 Right Shift

64-Common Dot-matrix STN LCD Driver

4.3.2 LEFT SHIFT

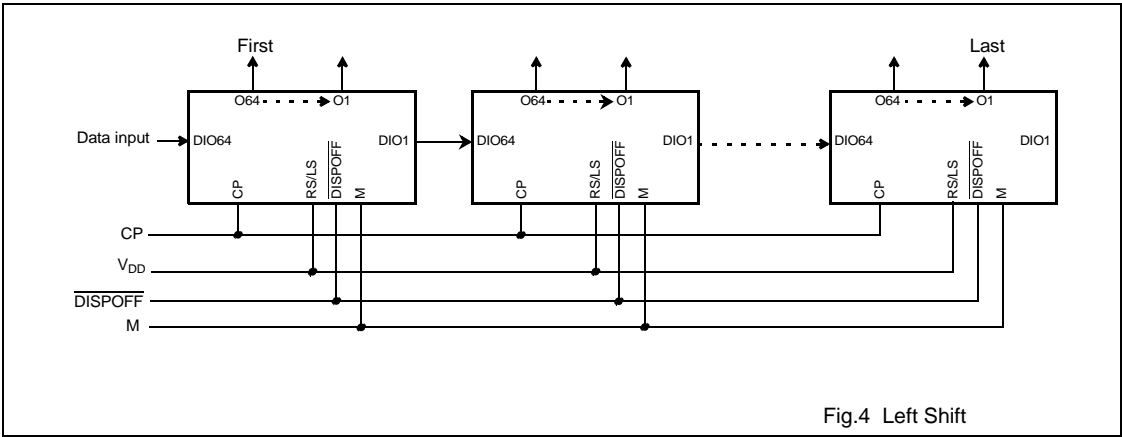

Fig.4 Left Shift

64-Common Dot-matrix STN LCD Driver

5 ABSOLUTE MAXIMUM RATING**Table 5** Absolute maximum rating

$V_{DD} = 5\text{ V} \pm 10\%$; $V_{SS} = 0\text{ V}$; all voltages with respect to V_{SS} unless otherwise specified; $T_{amb} = 25 \pm 2^\circ\text{C}$.

SYMBOL	PARAMETER	MIN.	MAX.	UNIT
V_{DD}	Voltage on the V_{DD} input	-0.3	+7.0	V
$V_{DD}-V_{EE}$	LCD bias voltage, note 1	0	22	V
$V_i(\text{max})$	Maximum input voltage to input pins	-0.3	$V_{DD} + 0.3$	
T_{amb}	Operating ambient temperature range	-20	+ 85	$^\circ\text{C}$
T_{stg}	Storage temperature range	-40	+125	$^\circ\text{C}$

Note:

1. The following condition must always be met: $V_{DD} \geq V1 > V2 > V5 > V_{EE}$.

64-Common Dot-matrix STN LCD Driver

6 DC CHARACTERISTICS

Table 6 DC Characteristics

$V_{DD} = 5 V \pm 10\%$; $V_{SS} = 0 V$; all voltages with respect to V_{SS} unless otherwise specified; $T_{amb} = 25 \pm 2 \text{ }^\circ\text{C}$.

SYMBOL	PARAMETER	CONDITIONS	MIN.	TYP.	MAX.	UNIT
V_{DD}	Supply voltage for control logic	Please refer to Fig. 10 for DC power-up sequence.	2.7	5.0	5.5	V
$V_{DD}-V_{EE}$	LCD bias voltage	Note 1.	8		20	
V_{IL}	Input LOW voltage of input pins	DIO1, DIO64, CP, M, RS/LS, DISPOFF	0		$0.2V_{DD}$	V
V_{IH}	Input HIGH voltage of input pins	DIO1, DIO80, CP, M, RS/LS, DISPOFF	$0.8V_{DD}$		V_{DD}	V
I_{IL}	Input LOW leakage current of input pins (i. e. Reverse leakage current of input ESD protection diode)	$V_{IN}=V_{SS}$, DIO1, DIO80, CP, M, RS/LS, DISPOFF			1	μA
I_{IH}	Input HIGH leakage current of input pins (i. e. Reverse leakage current of input protection diode)	$V_{IN}=V_{DD}$, DIO1, DIO80, CP, M, RS/LS, DISPOFF			1	μA
V_{OL}	Output LOW voltage level of the DIO1 and DIO64 pins	$I_{OL}=400\mu\text{A}$	0.0		0.4	V
V_{OH}	Output HIGH voltage level of the DIO1 and DIO64 pins	$I_{OH}=-400\mu\text{A}$	$V_{DD} - 0.4$		V_{DD}	V
I_{STBY}	Standby current	Note 2.			2	μA
I_{SS}	Operating current	Note 3.			80	μA
I_{EE}	Operating current	Note 4.			80	μA
C_i	Input capacitance of the CP pin	The CP clock frequency is 1 MHz.		5.0		pF
R_{ON}	Driver ON resistance at $V_{LCD}=18 V$	Note 5.			1.5	$K\Omega$

Notes:

- The following condition, $V_{DD} \geq V1 > V2 > V5 > V_{EE}$, must always be met.
- $V_{DD}-V_{EE}=18 V$, CP=LOW, Output unloaded; measured at the V_{SS} pin.
- Condition for the measurement: $V_{LCD}=V_{DD}-V_{EE}=18 V$, $V_{DD}=5.5 V$, CP=14 KHz, No load. This is the current flowing from V_{DD} to V_{SS} , measured at the V_{SS} pin.
- Condition for the measurement: $V_{LCD}=V_{DD}-V_{EE}=18 V$, $V_{DD}=5.5 V$, CP=14 KHz, No load. This is the current flowing from V_{DD} to V_{EE} , measured at the V_{EE} pin.
- Condition for the measurement: $V_{DD}-V_{EE}=18 V$, $|V_{DE}-V_O|=0.5 V$, where V_{DE} = one of V1, V2, V5, or V_{EE} . $V1=V_{DD}$, $V2=(10/11) \times (V_{DD}-V_{EE})$, $V5=(1/11) \times (V_{DD}-V_{EE})$. For the driver circuits (O1~O64), please refer to Section 9, Pin Circuits.

64-Common Dot-matrix STN LCD Driver

7 AC CHARACTERISTICS

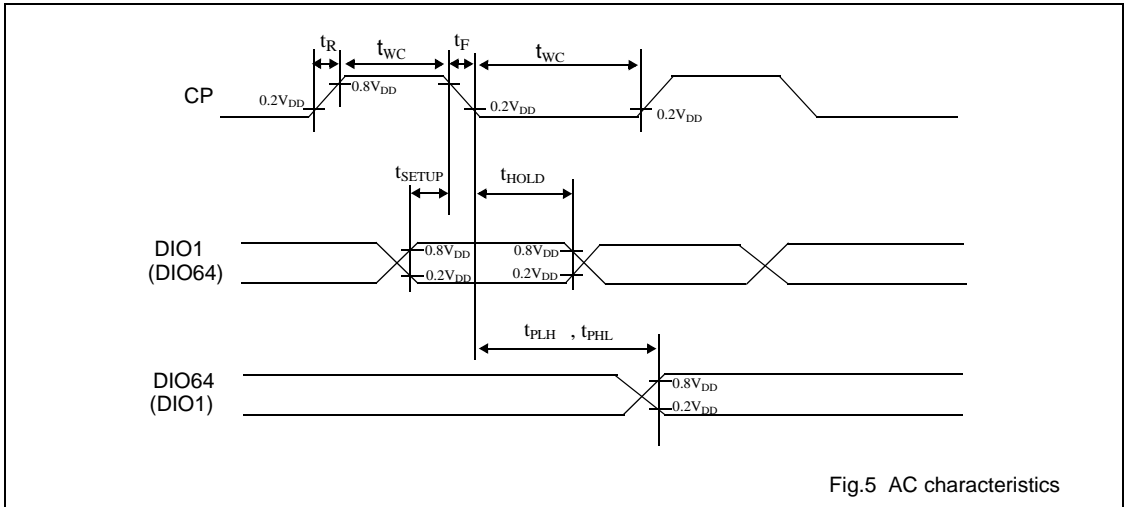

Fig.5 AC characteristics

Table 7 AC Characteristics

$V_{DD} = 5\text{ V} \pm 10\%$; $V_{SS} = 0\text{ V}$; all voltages with respect to V_{SS} unless otherwise specified; $T_{amb} = 25 \pm 2\text{ }^\circ\text{C}$.

SYMBOL	PARAMETER	CONDITIONS	MIN.	MAX.	UNIT
f_{CP}	CP clock frequency			1.0	MHz
T_{WC}	CP clock pulse width		120		ns
t_{SETUP}	Input data setup time	Data change of DIO1 and DIO64 to the falling edge of the CP clock.	100		ns
t_{HOLD}	Input data hold time.	Falling edge of the CP clock to the data change of DIO1 and DIO64.	100		ns
t_R	CP rise time			60	ns
t_F	CP fall time			60	ns
t_{PLH}, t_{PHL}	Output delay time	CP→DIO1, CP→DIO64, Load=30 pF.		210	ns

64-Common Dot-matrix STN LCD Driver

8 LCD BIAS VOLTAGE

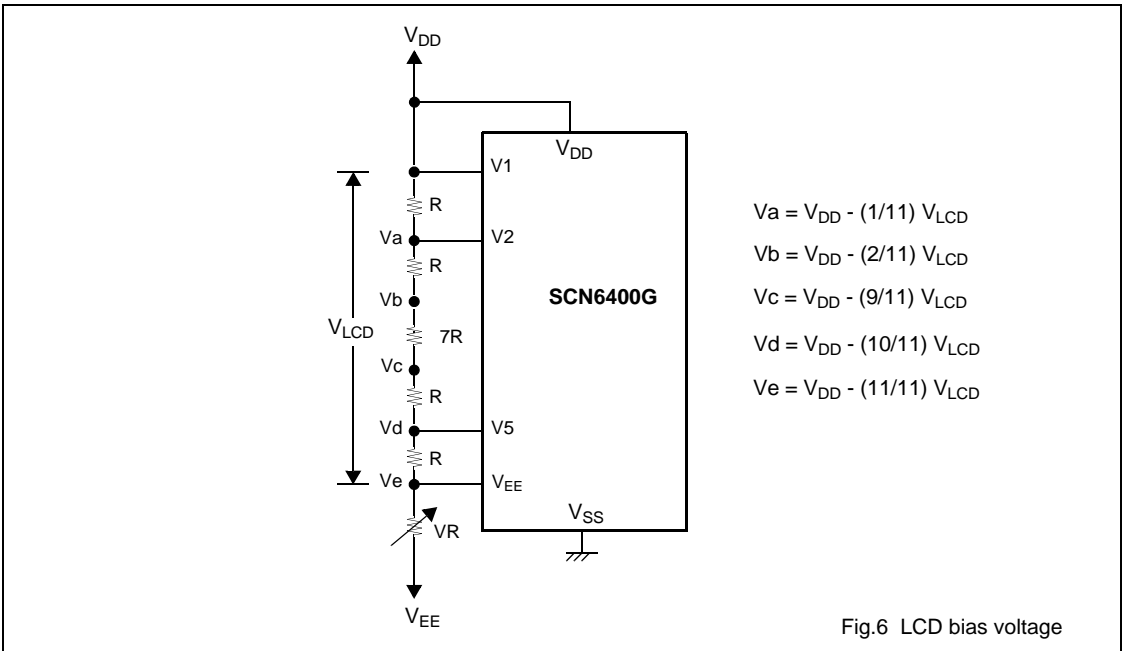

64-Common Dot-matrix STN LCD Driver

9 PIN CIRCUITS

Table 8 MOS-level schematics of all input, output, and I/O pins.

SYMBOL	Input/output	CIRCUIT	NOTES
DIO1, DIO64	I/O		
CP, RS/LS, M, DISPOFF	Inputs		
O1~O64, V1, V2, V5, VEE	Driver outputs, High voltage inputs		

64-Common Dot-matrix STN LCD Driver

10 TYPICAL APPLICATION(1)

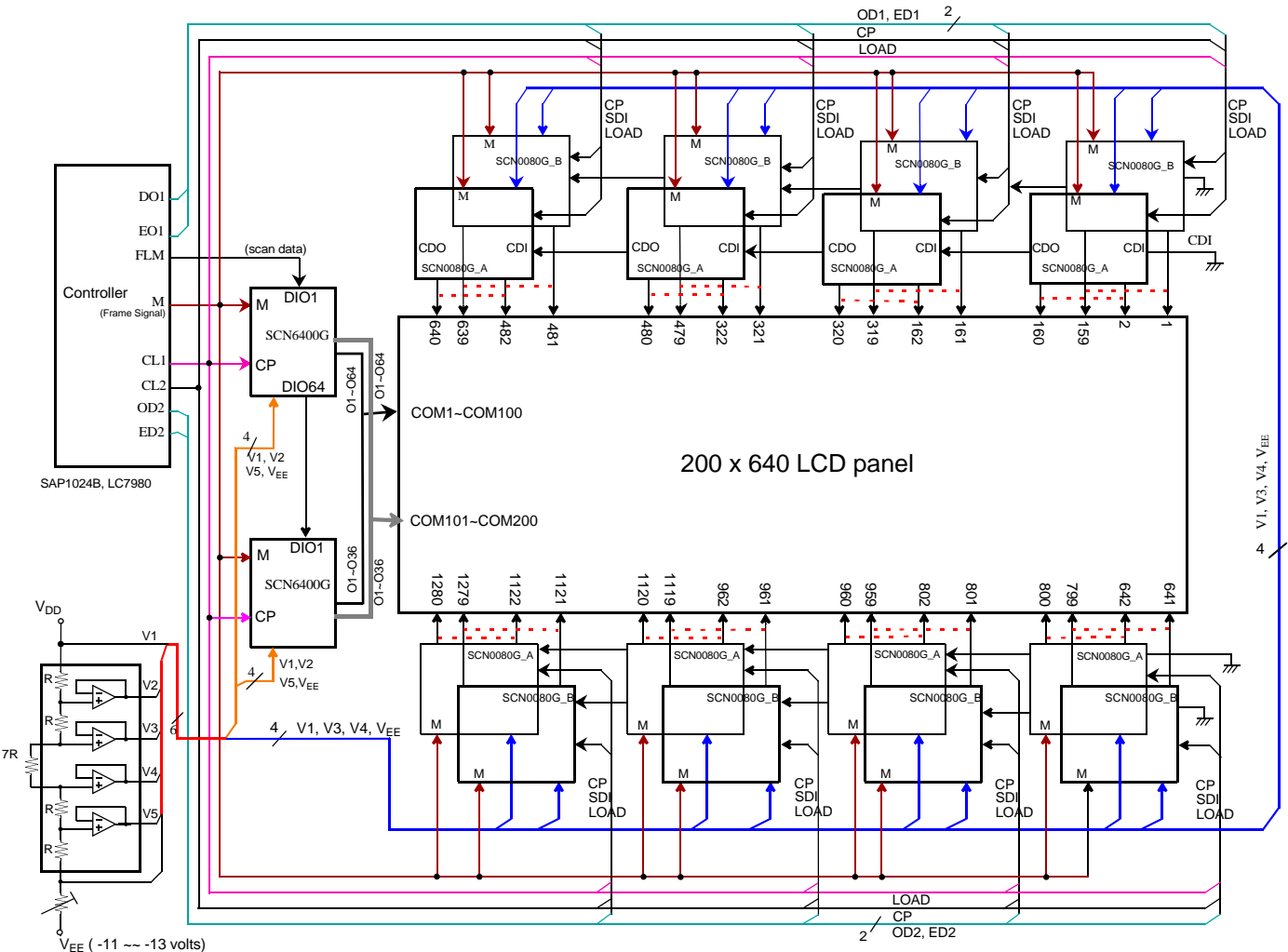

Fig.7 200 x 640 dots application

64-Common Dot-matrix STN LCD Driver

11 TYPICAL APPLICATION 2

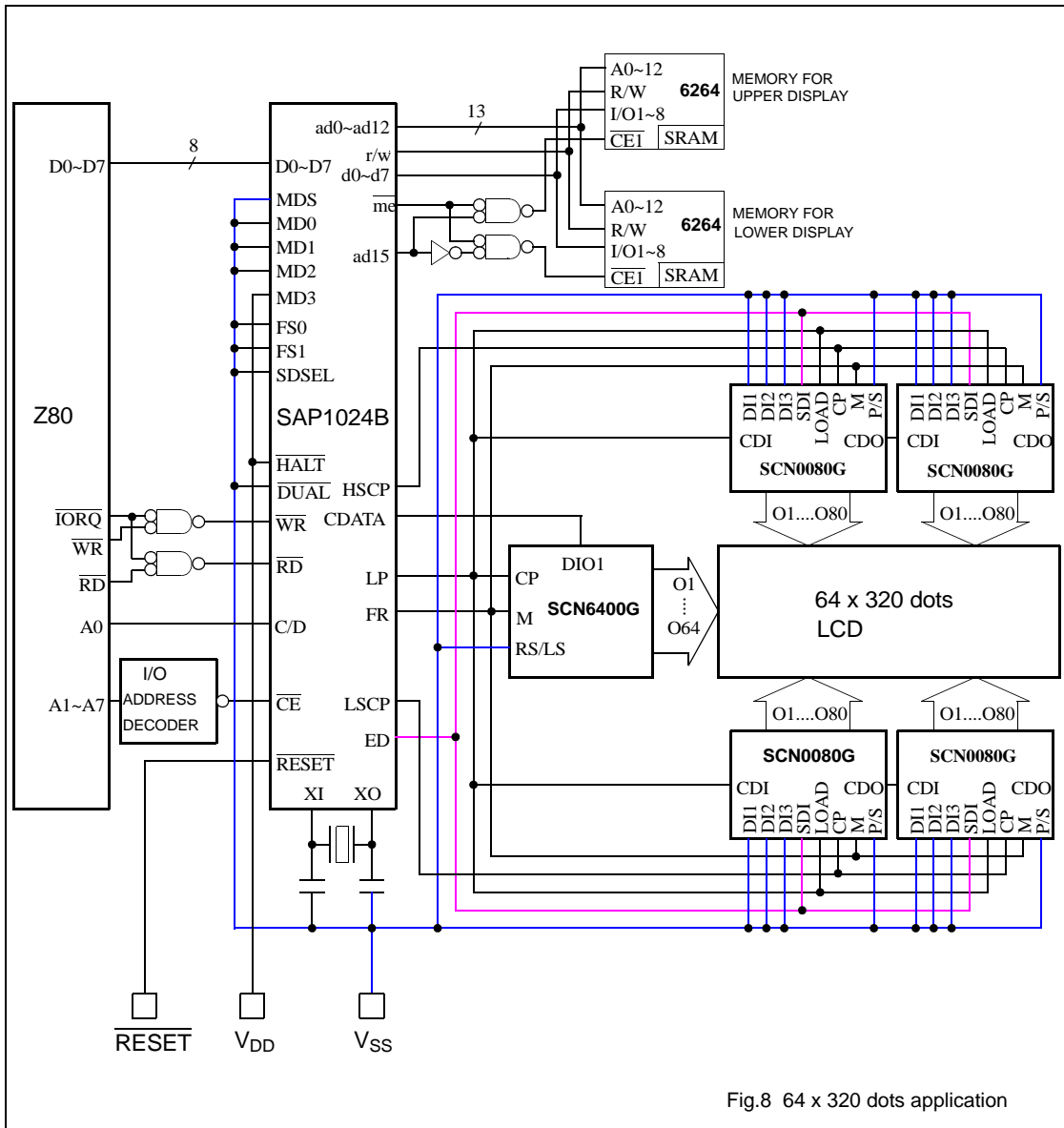

Fig.8 64 x 320 dots application

64-Common Dot-matrix STN LCD Driver

12 TYPICAL APPLICATION 3

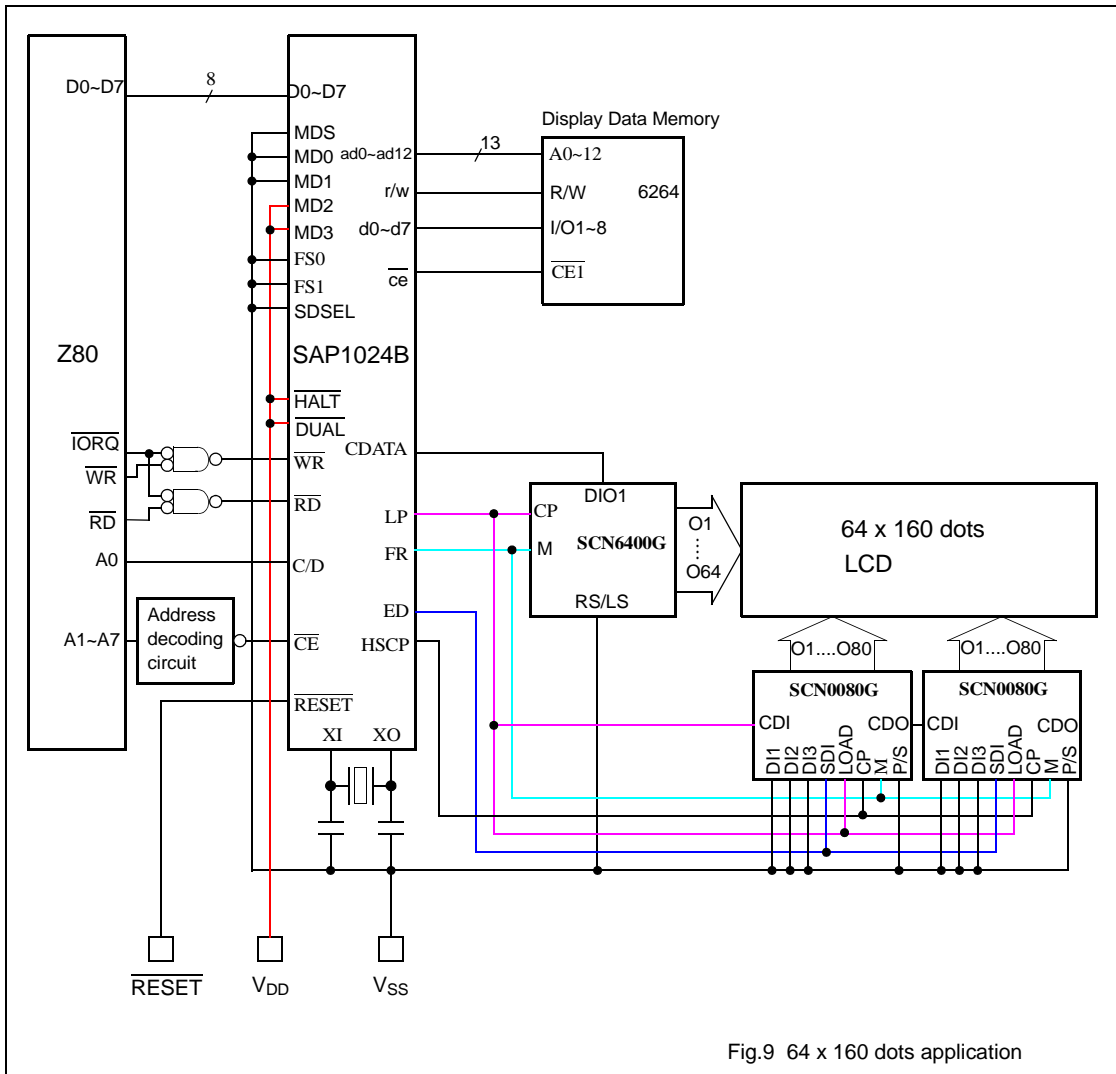
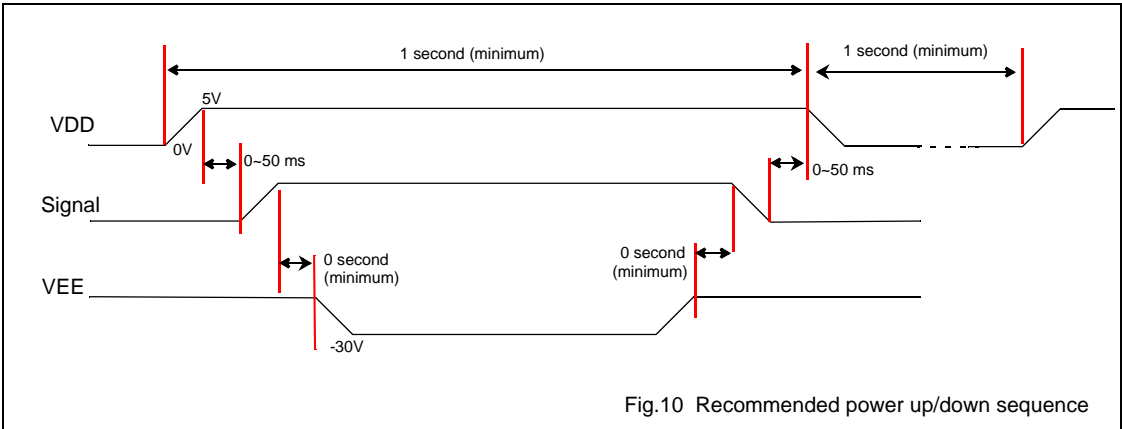

Fig.9 64 x 160 dots application

64-Common Dot-matrix STN LCD Driver

13 APPLICATION NOTES

1. It is recommended that the following power-up sequence be followed to ensure reliable operation of your display system. As the ICs are fabricated in CMOS and there is intrinsic latch-up problem associated with any CMOS devices, proper power-up sequence can reduce the danger of triggering latch-up. When powering up the system, control logic power must be powered on first. When powering down the system, control logic must be shut off later than or at the same time with the LCD bias (V_{EE}).



SYMBOLS	MIN.	NOM	MAX.
A	—	—	3.40
A1	0.25	—	0.50
A2	2.50	2.70	2.90
b	0.29	—	0.45
D	23.20 BASIC		
D1	20.00 BASIC		
e	0.8 BASIC		
E	17.20 BASIC		
E1	14.00 BASIC		
L	0.73	0.88	1.03
L1	1.60 REF.		
θ°	0	3.5	7

UNIT : mm

NOTES:

1. JEDEC OUTLINE: MS-022 GB-1
2. DATUM PLANE \square IS LOCATED AT THE BOTTOM OF THE MOLD PARTING LINE COINCIDENT WITH WHERE THE LEAD EXITS THE BODY.
3. DIMENSIONS D1 AND E1 DO NOT INCLUDE MOLD PROTRUSION. ALLOWABLE PROTRUSION IS 0.25 mm PER SIDE. DIMENSIONS D1 AND E1 DO INCLUDE MOLD MISMATCH AND ARE DETERMINED AT DATUM PLANE \square .
4. DIMENSION b DOES NOT INCLUDE DAMBAR PROTRUSION .

SCN6400G
QFP80 Package Outline Drawing

14 PACKAGE INFORMATION

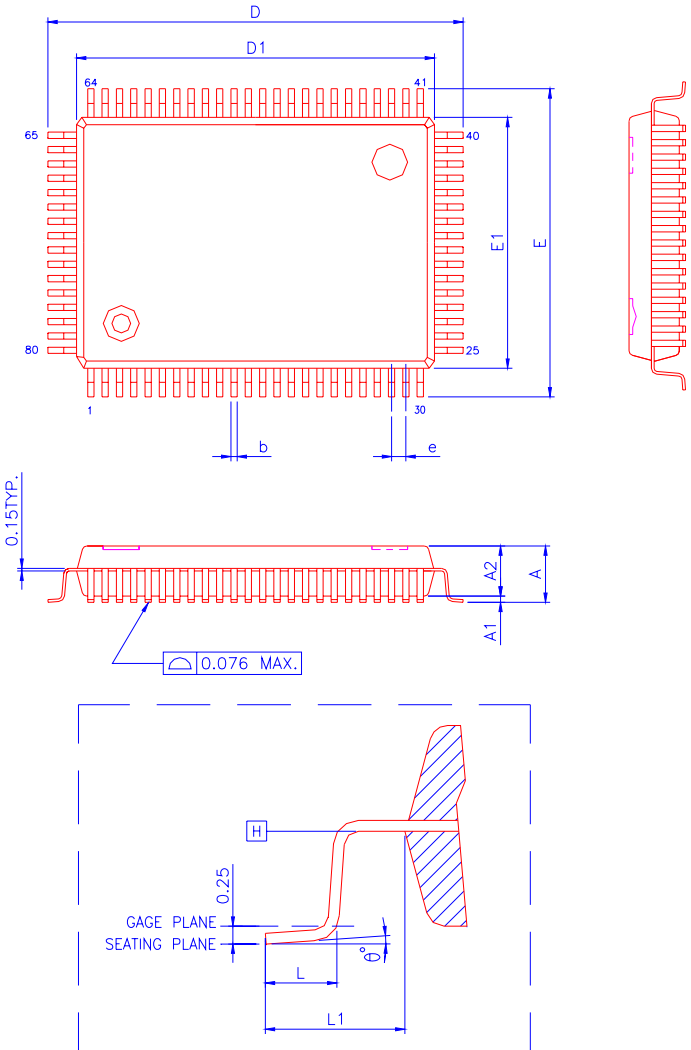

64-Common Dot-matrix STN LCD Driver

15 SOLDERING

15.1 Introduction

There is no soldering method that is ideal for all IC packages. Wave soldering is often preferred when through-hole and surface mounted components are mixed on one printed-circuit board. However, wave soldering is not always suitable for surface mounted ICs, or for printed-circuits with high population densities. In these situations reflow soldering is often used.

This text gives a very brief insight to a complex technology. For more in-depth account of soldering ICs, please refer to dedicated reference materials.

15.2 Reflow soldering

Reflow soldering techniques are suitable for all QFP packages.

The choice of heating method may be influenced by larger plastic QFP packages (44 leads, or more). If infrared or vapour phase heating is used and the large packages are not absolutely dry (less than 0.1% moisture content by weight), vaporization of the small amount of moisture in them can cause cracking of the plastic body. For more information, please contact Avant for drypack information.

Reflow soldering requires solder paste (a suspension of fine solder particles, flux and binding agent) to be applied to the printed-circuit board by screen printing, stencilling or pressure-syringe dispensing before package placement.

Several techniques exist for reflowing; for example, thermal conduction by heated belt. Dwell times vary between 50 and 300 seconds depending on heating method. Typical reflow temperatures range from 215 to 250 °C.

Preheating is necessary to dry the paste and evaporate the binding agent. Preheating duration: 45 minutes at 45 °C.

15.3 Wave soldering

Wave soldering is **not** recommended for QFP packages. This is because of the likelihood of solder bridging due to closely-spaced leads and the possibility of incomplete solder penetration in multi-lead devices.

If wave soldering cannot be avoided, the following conditions must be observed:

- **A double-wave (a turbulent wave with high upward pressure followed by a smooth laminar wave) soldering technique should be used.**
- **The footprint must be at an angle of 45° to the board direction and must incorporate solder thieves downstream and at the side corners.**

During placement and before soldering, the package must be fixed with a droplet of adhesive. The adhesive can be applied by screen printing, pin transfer or syringe dispensing. The package can be soldered after the adhesive is cured.

Maximum permissible solder temperature is 260 °C, and maximum duration of package immersion in solder is 10 seconds, if cooled to less than 150 °C within 6 seconds. Typical dwell time is 4 seconds at 250 °C.

A mildly-activated flux will eliminate the need for removal of corrosive residues in most applications.

15.4 Repairing soldered joints

Fix the component by first soldering two diagonally- opposite end leads. Use only a low voltage soldering iron (less than 24 V) applied to the flat part of the lead. Contact time must be limited to 10 seconds at up to 300 °C. When using a dedicated tool, all other leads can be soldered in one operation within 2 to 5 seconds between 270 and 320 °C.

64-Common Dot-matrix STN LCD Driver

16 LIFE SUPPORT APPLICATIONS

Avant's products are not designed for use in life support appliances, devices, or systems where malfunction of these products can possibly result in personal injury. Avant customers using or selling these products for use in such applications do so at their own risk and agree to fully indemnify Avant for any damages resulting from such improper use or sale.