



OTD9960A

960/900/864/816ch output Gate driver

Preliminary

JAN. 26, 2011

Version 0.3

Table of Contents

	<u>PAGE</u>
1. GENERAL DESCRIPTION	3
2. FEATURES	3
3. BLOCK DIAGRAM	3
4. SIGNAL DESCRIPTIONS	4
5. FUNCTIONAL DESCRIPTIONS	6
6. ELECTRICAL SPECIFICATIONS	10
6.1. ABSOLUTE MAXIMUM RATINGS	10
6.2. RECOMMENDED OPERATING CONDITIONS (OPTION)	10
6.3. ELECTRICAL CHARACTERISTICS	10
6.4. AC CHARACTERISTICS	11
6.5. TIMING WAVEFORMS	12
7. CHIP INFORMATION	13
7.1. PAD ASSIGNMENT	13
7.2. PAD DIMENSION	13
7.3. PAD LOCATIONS	14
7.4. ALIGNMENT MARK	20
8. DISCLAIMER	21
9. REVISION HISTORY	22

960/900/864/816ch output Gate driver

1. GENERAL DESCRIPTION

The OTD9960A is a 960/900/864/816-channel outputs gate driver, which is used for driving the gate line of TFT LCD panel. It is designed for 2-level output with 40V LCD driving voltage range.

2. FEATURES

- Gate driver for TFT LCD panel
- 960/900/864/816 channel outputs+2 pins (Fixed to VEE)
- LCD drive output sequence: Output shift directions can be selected. (G1→G960 or G960→G1)
- Usable with both positive / negative power supplies
- CMOS silicon gate (p-type)
- Cascade function for dot-expansion
- Input signal voltage: 2.3V to 3.6V
- Package: COG
- Chip size: 20208um × 670um
- Output bump pitch: 20um

3. BLOCK DIAGRAM

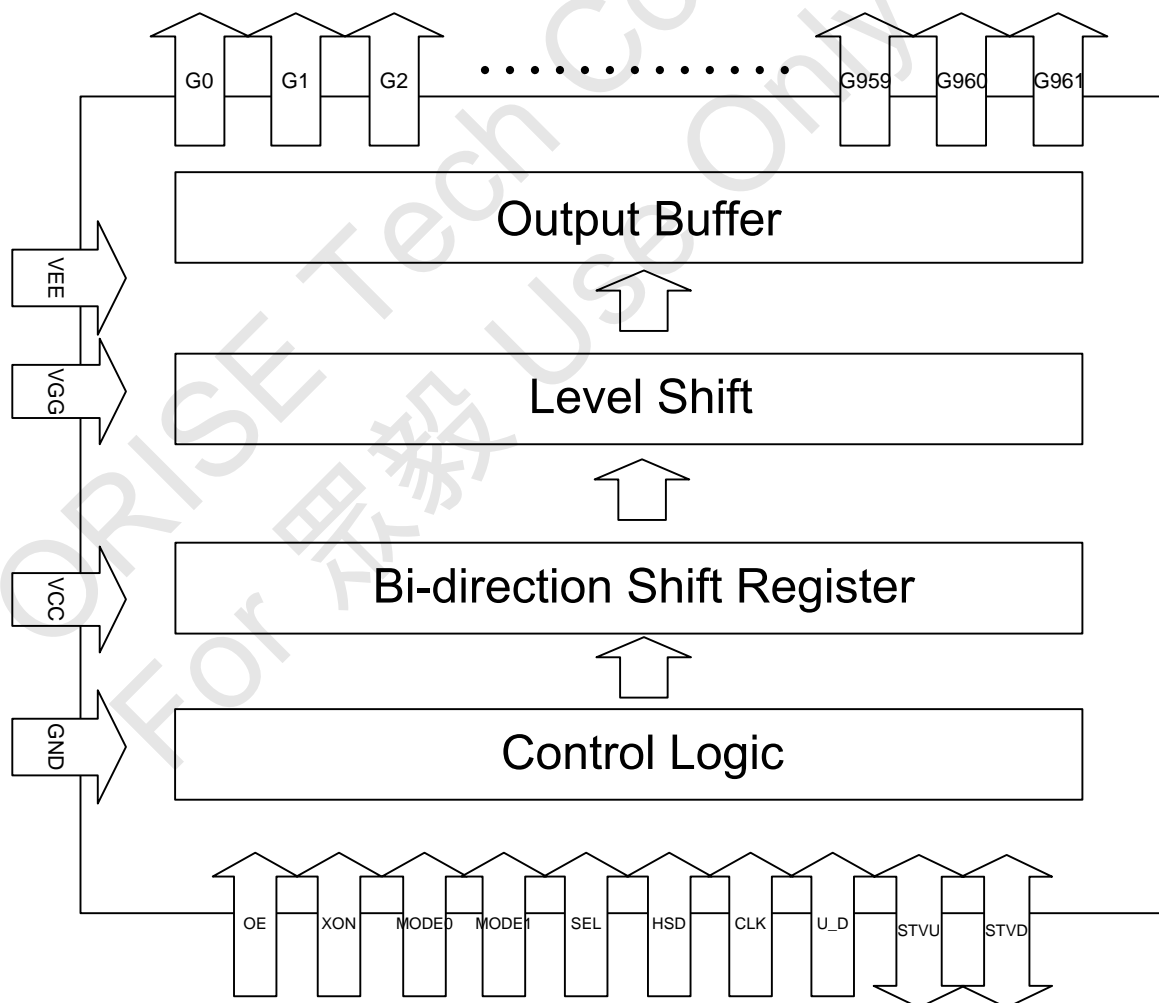

Note: (1) G0 and G961 are LCD panel auxiliary pins, these pins always output VEE level.

4. SIGNAL DESCRIPTIONS

Designation	I/O	Function	Description																				
CLK	I	Shift clock input	The clock for the internal shift registers.																				
U_D	I	Shift direction control pin	The shift direction of device internal shift register is controlled by this pin as shown below: U_D=H, STVD→G1→G2→...→G960→STVU U_D=L, STVU→G960→...→G2→G1→STVD																				
STVD STVU	I/O	Start pulse input/output pin	U_D=H, STVD is used for start pulse input STVU is used for start pulse output U_D=L, STVU is used for start pulse input STVD is used for start pulse output																				
OE	I	Output enable control	These pads are shorted internally, active high. When this pin is applied to "H", the channel outputs are disabled (= VEE). This condition will not affect the operation of the internal registers. OE control signal is independent with the CLK.																				
XOA	I	Output all-on control	When XOA is set to L, all outputs are fixed to VGG. Note that this pin has higher priority than OE. However, the content of shift register is not cleared. XOA is pulled high to VCC internally. When it is not used, connecting to VCC is recommended.																				
MODE0 MODE1	I	Channel mode selection	Channel mode selection <table border="1" style="width: 100%; border-collapse: collapse; text-align: center;"> <thead> <tr> <th>Output Channel</th> <th>Disable channel</th> <th>MODE1</th> <th>MODE0</th> </tr> </thead> <tbody> <tr> <td>960</td> <td>-</td> <td>H</td> <td>H</td> </tr> <tr> <td>900</td> <td>G453-G512</td> <td>H</td> <td>L</td> </tr> <tr> <td>864</td> <td>G433-G528</td> <td>L</td> <td>H</td> </tr> <tr> <td>854</td> <td>G425-G528, G959, G960</td> <td>L</td> <td>L</td> </tr> </tbody> </table>	Output Channel	Disable channel	MODE1	MODE0	960	-	H	H	900	G453-G512	H	L	864	G433-G528	L	H	854	G425-G528, G959, G960	L	L
Output Channel	Disable channel	MODE1	MODE0																				
960	-	H	H																				
900	G453-G512	H	L																				
864	G433-G528	L	H																				
854	G425-G528, G959, G960	L	L																				
SEL	I	-	SEL=H, Normal operating. Normally pull up. SEL=L, for testing																				
G1~G960	O	Driver output	The output is either VGG or VEE for driving the gate line of TFT LCD panel.																				
HSD	I	Output sequence control	Normally pulled high. When U/D="H" HSD='L' : STVD→G2→G1→G4→G3→...→G958→G957→G960→G959→STVU HSD='H' : STVD→G1→G2→G3→G4→...→G957→G958→G959→G960→STVU When U/D="L" HSD='L' : STVU→G959→G960→G957→G958→...→G3→G4→G1→G2→STVD HSD='H' : STVU→G960→G959→G958→G957→...→G4→G3→G2→G1→STVD																				
G0, G961	O	Auxiliary pins	These two pins always output VEE level.																				
PATH	S	Internal pass	The pins are shorted internally.																				
VCC	I	Power supply	Digital power supply																				
GND	I	Power supply	Grounding for VCC																				
VGG	I	Power supply	Power supply for Gate on output.																				
VEE	I	Power supply	Power supply for Gate off output.																				

4.1. Pin Arrangement

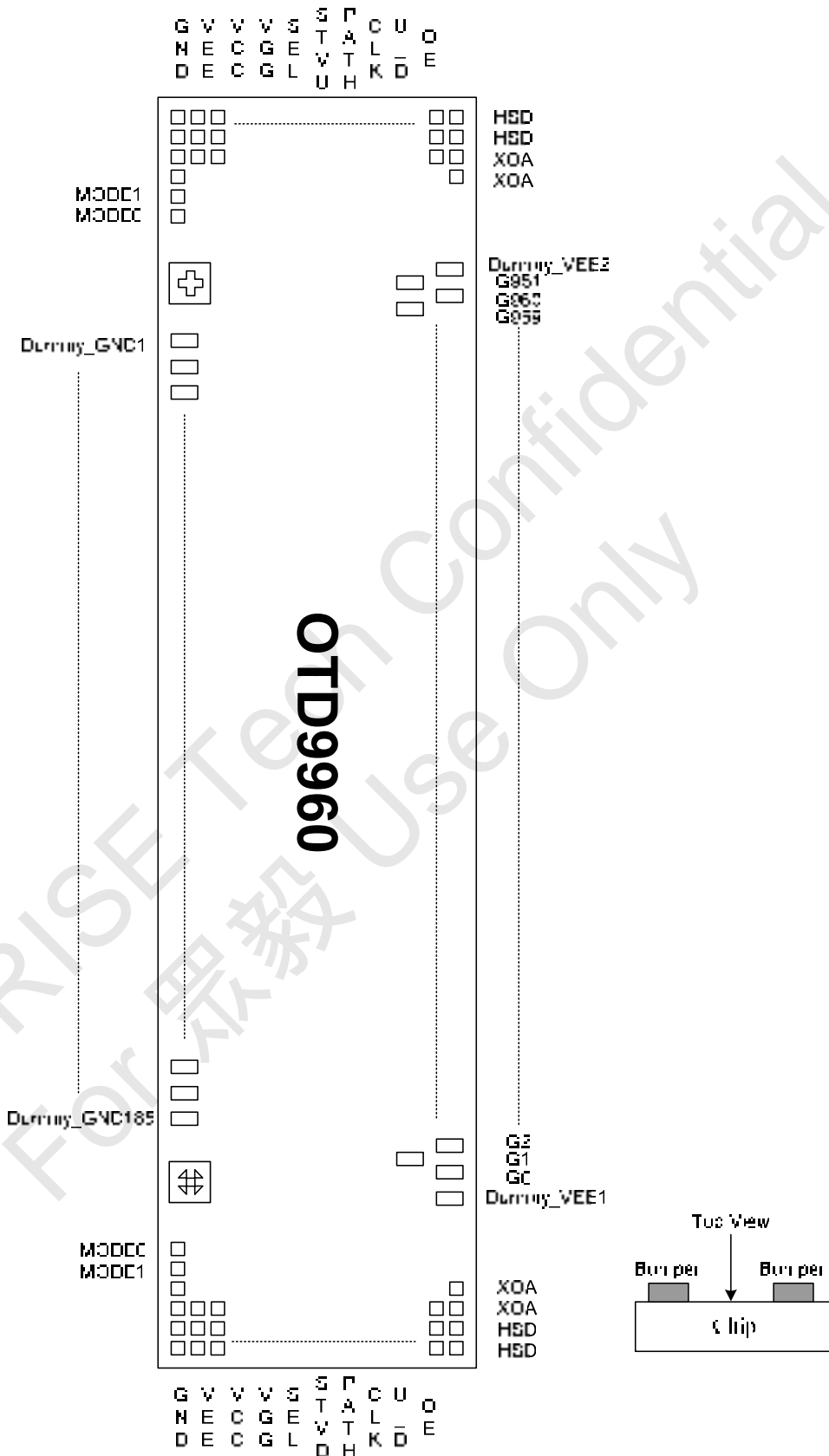

5. FUNCTIONAL DESCRIPTIONS

5.1. Device operation

When U_D=H, MODE0=H & MODE1=H, the STVD start pulse input is sensed on the rising edge of CLK and stored in the first stage of shift register, which makes the first scan signal output from the G1 pin. While stored data is transferred to the next stage shift register on the rising edge of next CLK, new data of STVD is sensed and stored simultaneously.

The output pin (G1 to G960) supplies VGG voltage or VEE voltage to the LCD panel depending on the data stored in the shift register. For normal operation, a VGG voltage is outputted one by one from G1 to G960 in synchronization with CLK pulse.

After 960 CLK rising edge are past, the STVU goes up to high level at the 960th falling edge of CLK and goes down to low level at the 961st falling edge of CLK. This STVU output signal becomes the STVD start pulse input of next cascaded gate driver.

When OE=H, the corresponding output channels are fixed to VEE level regardless of CLK. The channel output returns to normal status as soon as OE goes back to L.

Example of input/output timing (U_D=H, MODE0=H, MODE1=H, OE & XOA)

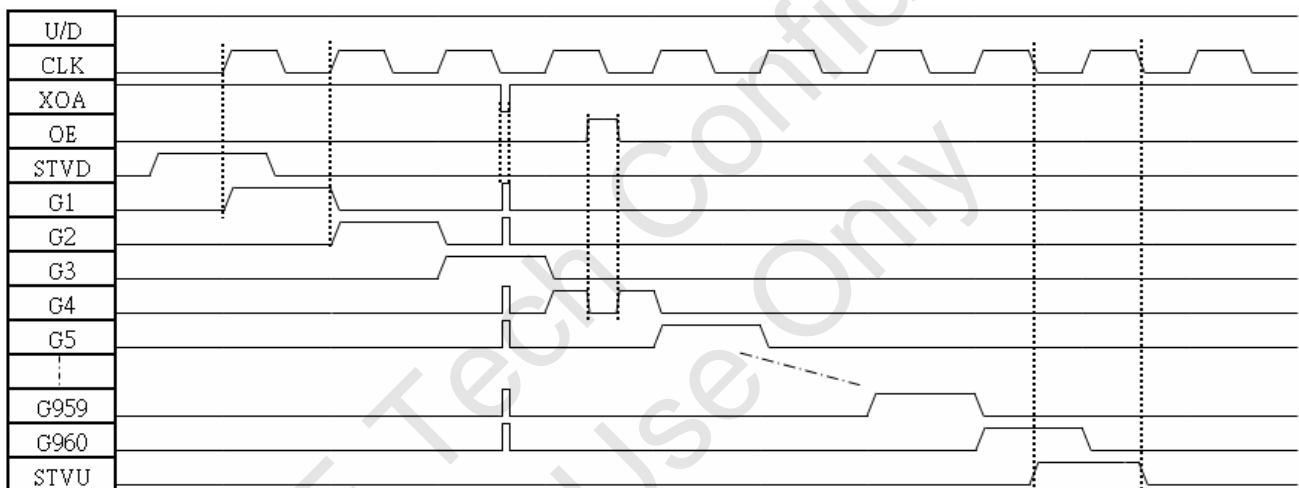

Example of input/output timing (U_D=L, MODE0=H, MODE1=H, OE & XOA)

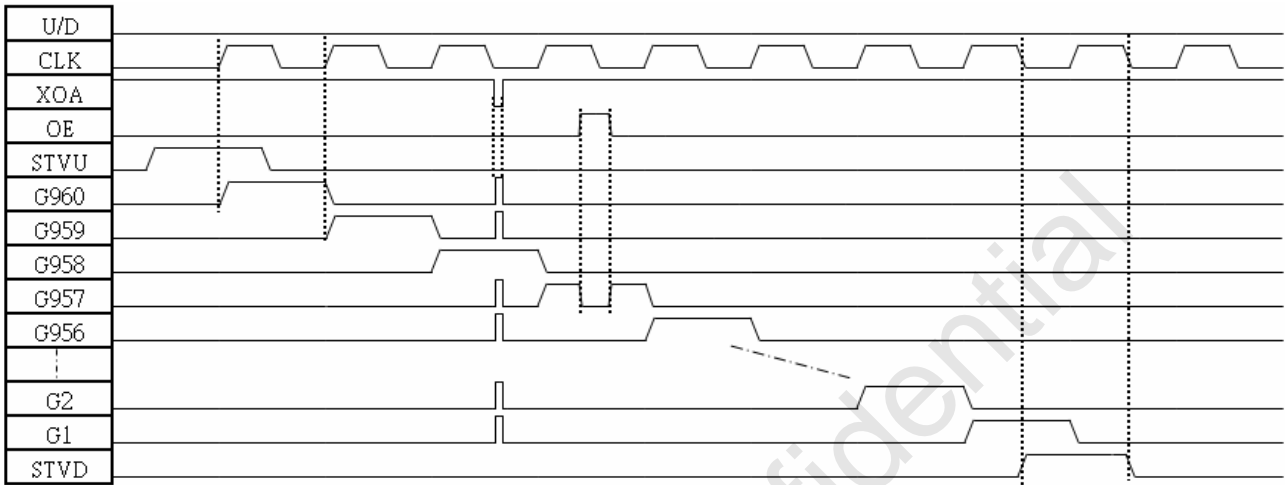

5.2. Start Pulse Usage

The available start pulse is in the following diagram.

■ Signal Start Pulse Input

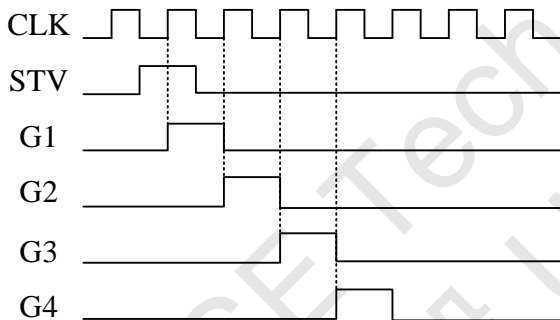

■ Long Start Pulse Input (2 CLK Period)

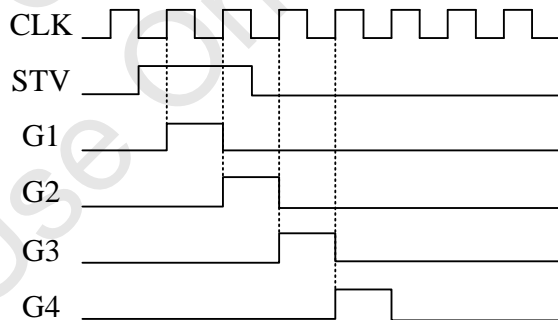

■ Dual Start Pulse Input

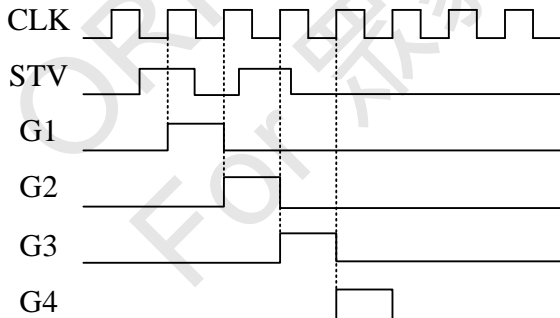

■ Long Start Pulse Input (More Than 2 CLK Period)

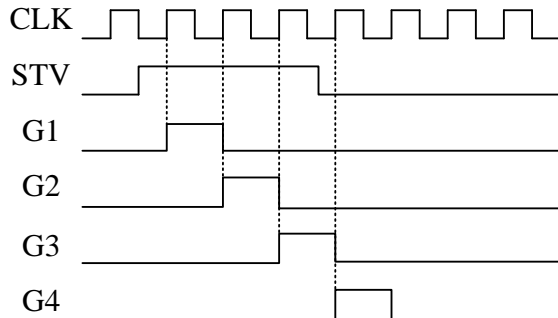

Note1: The Output Turn-On Timing will change following by Start Pulse Waveform.

5.3. Power on sequence

This LSI has a high-voltage LCD drive circuits, so it may be permanently damaged by a high current which may flow if voltage is supplied to the LCD drive power supply while the logic system power supply is floating. Therefore, when connecting the power supply, observe the following sequence.

Logic system power supply (VCC), low-level LCD drive power supply (VEE) → Logic input → High-level LCD drive power supply (VGG)

When disconnecting the power supply, follow the reverse sequence.

Since the logic state of internal circuit is unstable immediately after the logic system power is supplied, input CLK and STVD/STVU while initializing the internal circuit (minimum input clock number is 600 CLK.)

Power on sequence

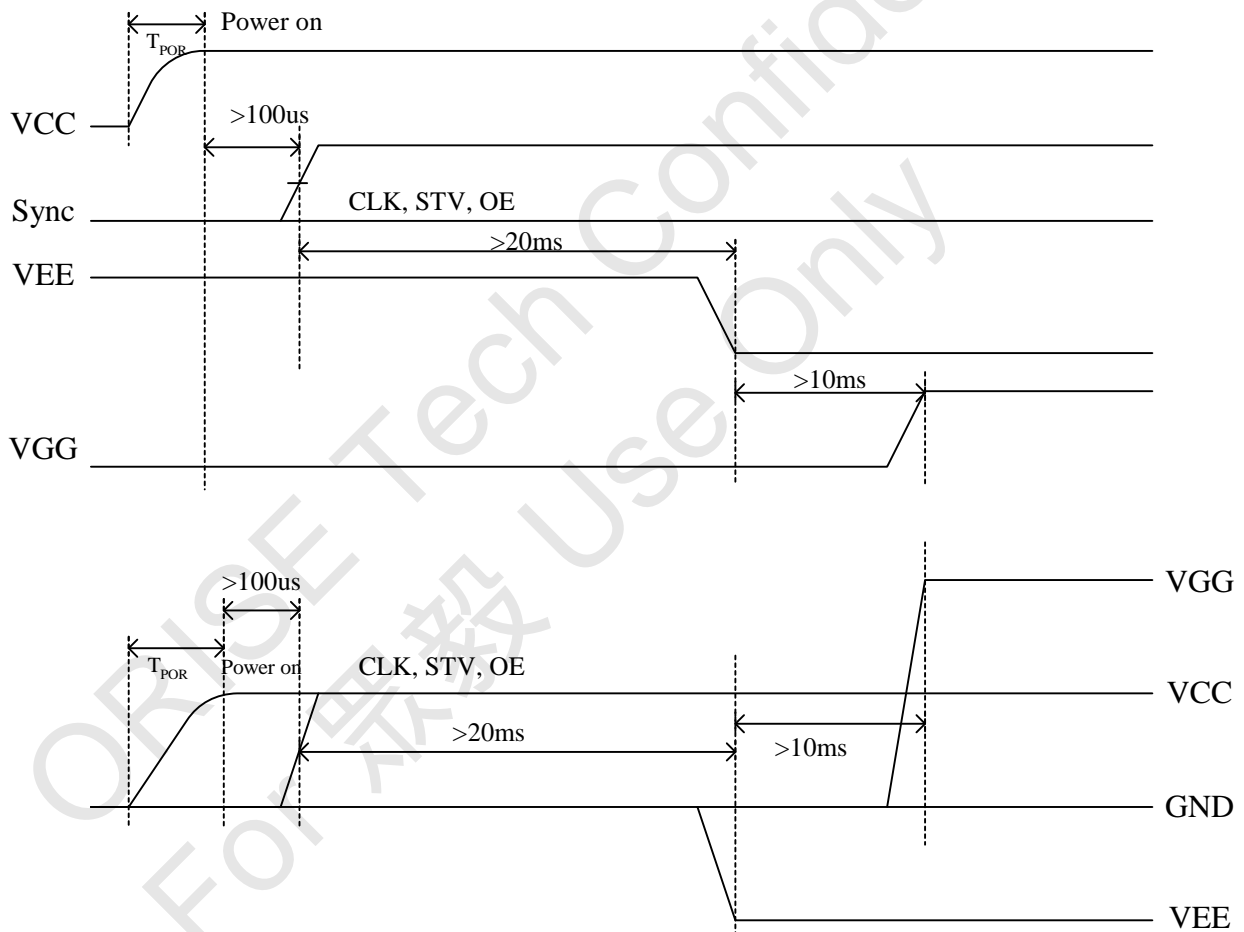

Power off sequence

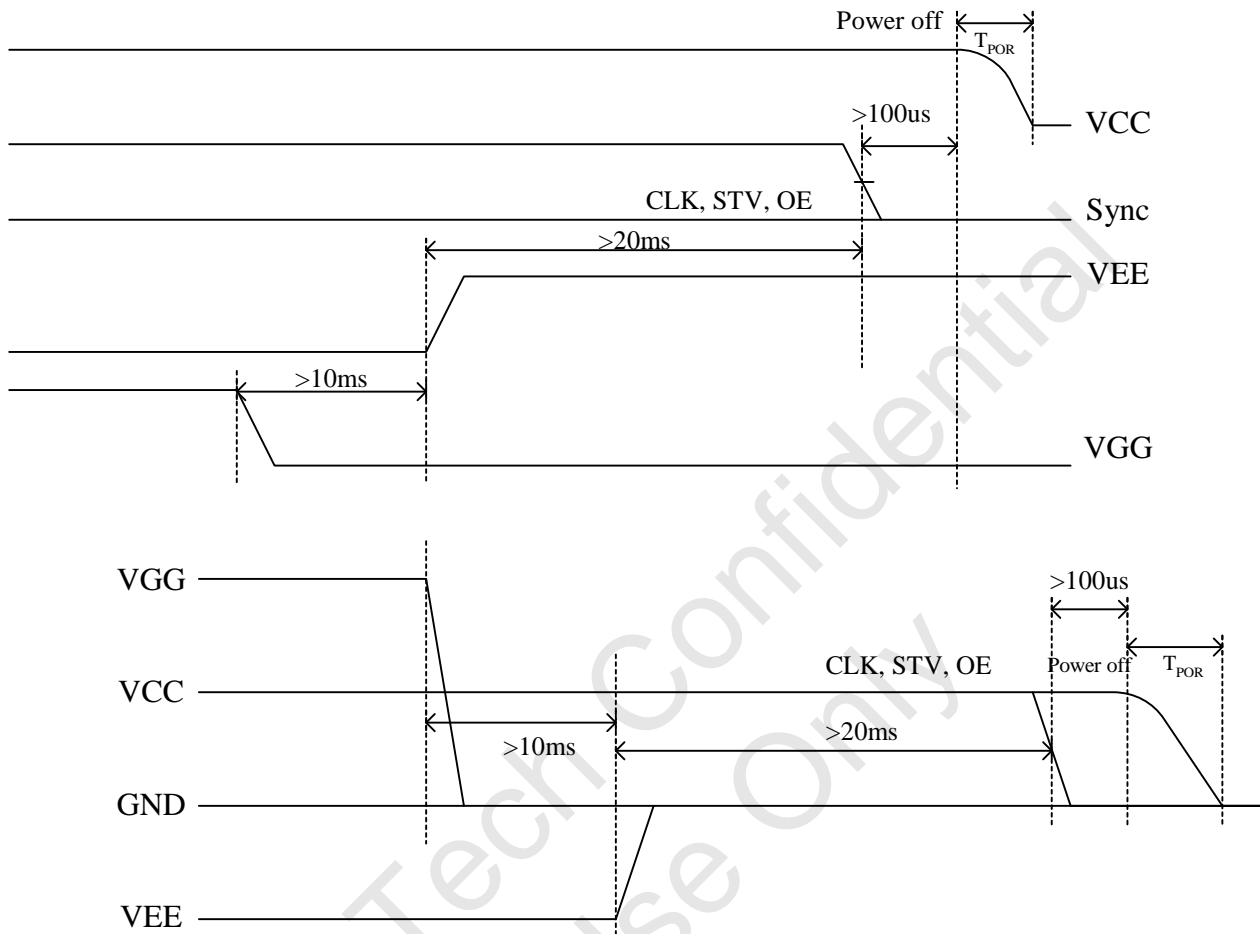

5.4. Power level

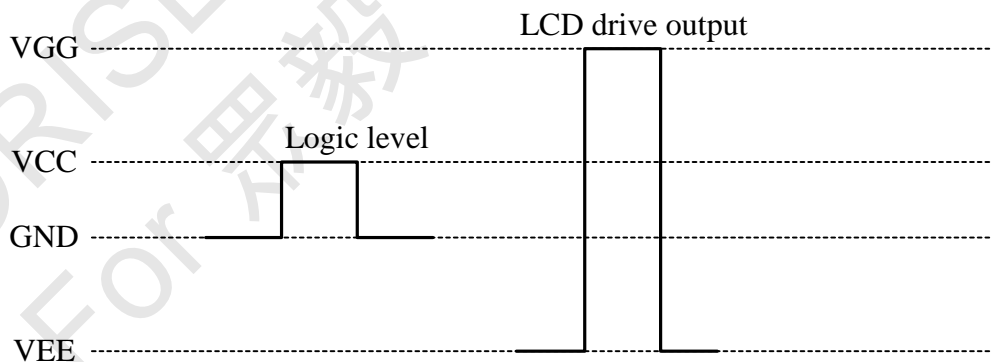

Note: For the input signals: CLK, XOA, OE, U_D, STVD, STVU, "High" level=VCC, "Low" level=GND

This figure above is example for power supply sequence of power supply pin.

6. ELECTRICAL SPECIFICATIONS

6.1. Absolute Maximum Ratings

Parameter	Symbol	Rating			Unit	Note
		Min.	Typ.	Max.		
Power Supply Voltage for Logic Circuits	VCC	-0.3	-	+7	V	1, 2
Power Supply Voltage for LCD Drive Circuits	VGG	-0.3	-	+42	V	
	VEE	-20	-	+0.3	V	
Input Voltage	V _{IN}	-0.3	-	VCC+0.3	V	
Operating Temperature	T _A	-40	-	+85	°C	
Storage Temperature	T _{STG}	-55	-	+125	°C	

Note1: The maximum applicable voltage on any pin with respect to 0V.

Note2: Device is subject to be damaged permanently if stresses beyond those absolute maximum ratings listed above.

6.2. Recommended Operating Conditions (option)

Parameter	Symbol	Rating			Unit	Note
		Min.	Typ.	Max.		
Power Supply Voltage for Logic Circuits	VCC	2.3	3.3	3.6	V	Note
Power Supply Voltage for LCD Drive Circuits	VGG	7	-	VEE+40	V	Note
	VEE	-20	-	-5	V	Note
Power Supply Range	VGG -VEE	12	-	40	V	Note

Note: The applicable voltage on any pin with respect to GND (0V)

6.3. Electrical Characteristics

Parameter	Symbol	Rating			Unit	Conditions
		Min.	Typ.	Max.		
High Level Input Voltage	V _{IH}	0.7VCC	-	VCC	V	VCC=3.3V
Low Level Input Voltage	V _{IL}	GND	-	0.3VCC		VCC=3.3V
High Level Output Current	I _{XOA}	0.5			mA	VGG=25V, VEE=-15, Driving current, VO=VGG-0.5V
Low Level Output Current	I _{XOL}	0.5			mA	VGG=25V, VEE=-15, Sinking current, VO=VEE+0.5V
High Level Output Current	I _{POH}	200			μA	VCC=3.3V, STVD/STVU, VO=VCC-0.3V
Low Level Output Current	I _{POL}	200			μA	VCC=3.3V, STVD/STVU, VO=0.3V
Pull High Resistance	R _{PU}	70	200	400	kΩ	XOA, MODE0, MODE1, SEL0, SEL1, F_Ctrl, U_D
Input Leakage Current	I _{IN}	-	-	±1	μA	Except XOA, MODE0, MODE1, SEL0, SEL1, F_Ctrl, U_D
VCC Power Consumption	I _{VCC}	-	-	50	μA	No load
VGG Power Consumption	I _{VGG}	-	-	100	μA	No load
VEE Power Consumption	I _{VEE}	-	-	100	μA	No load

6.4. AC Characteristics

Parameter	Symbol	Rating			Unit	Conditions
		Min.	Typ.	Max.		
STVD/STVU Delay Time	Tdt	-	-	500	ns	VCC=3.3V, CL=20pF
Driver Output Delay Time	Tdo	-	-	900	ns	VGG=25, VEE=-15, VCC=3.3V, CL=200pF
Output Falling Time	Tthl	-	400	800	ns	VGG=25, VEE=-15, VCC=3.3V, CL=200pF, 10% to 90%
Output Rising Time	Ttlh	-	500	1000	ns	VGG=25, VEE=-15, VCC=3.3V, CL=200pF, 10% to 90%
XOA to Driver Output Delay Time	Txon	-	-	50	us	VGG=25, VEE=-15, VCC=3.3V, CL=200pF, 10% to 90%
OE to Driver Output Delay Time	Toe	-	-	900	ns	VGG=25, VEE=-15, VCC=3.3V, CL=200pF, 10% to 90%
Clock Frequency	Fclk	-	-	200	KHz	In cascade connection
Clock Rising Time	Trclk	-	-	100	ns	CL=20pF
Clock Falling Time	Tfclk	-	-	100	ns	CL=20pF
Clock Pulse Width (High & Low)	PWCLK	500	-	-	ns	
STVD/STVU Set-up Time	Tsu	200	-	-	ns	VCC=3.3V
STVD/STVU Hold Time	Thd	300	-	-	ns	VCC=3.3V
Output Enable pulse width	Twcl	1	-	-	us	
Power-On Reset slew time	TPOR	-	-	20	ms	From 0V to 90% VCC

6.5. Timing Waveforms

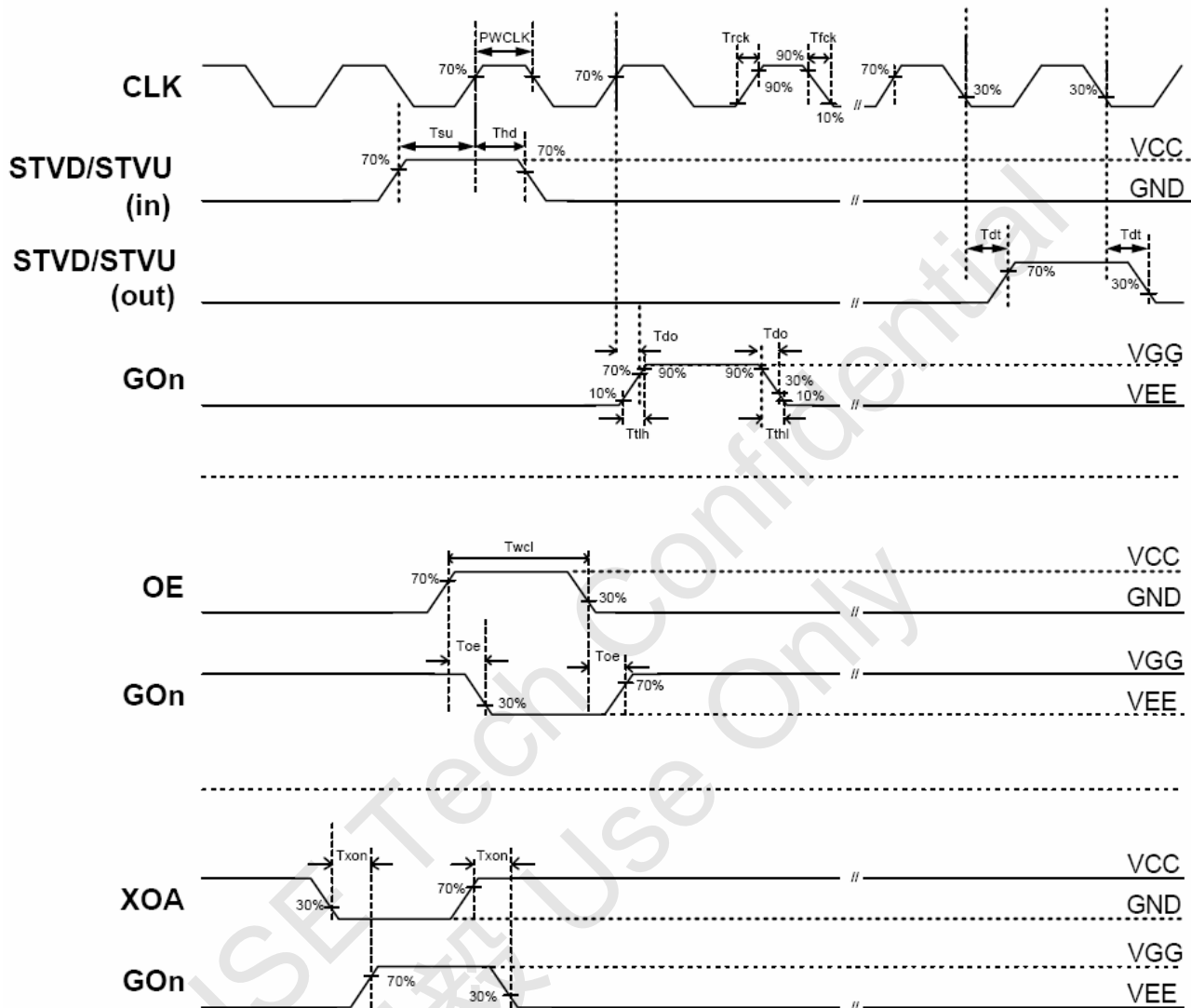

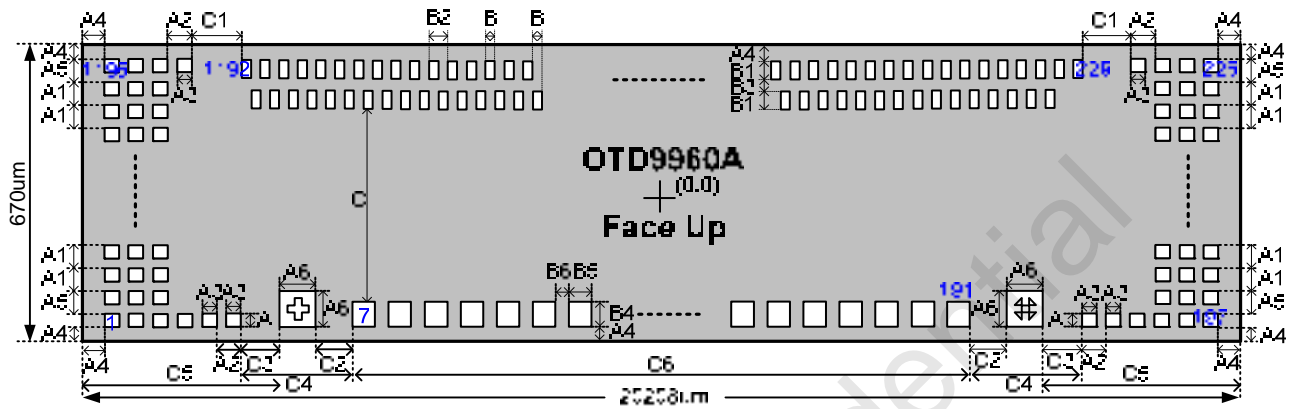
7. CHIP INFORMATION
7.1. PAD Assignment

Symbol	Dimensions	Symbol	Dimensions	Symbol	Dimensions
A	32	B	20	C	291
A1	52	B1	85	C1	57
A2	90	B2	40	C2	86
A3	70	B3	25	C3	86
A4	57	B4	70	C4	287
A5	54	B5	80	C5	663
A6	115	B6	20	C6	18480

Unit : um (scribe-line included)

7.2. PAD Dimension

Item	PAD No.	Size		Unit
		X	Y	
Chip Size		20208	670	um
Chip thickness		300 ± 20		
Pad pitch	(ILB) 7-191	100		
	(OLB) 229-1192	20		
	(SLB) 1-6, 192-228, 1193-1220	52		
Pad size	(ILB) 7-191	80	70	
	(OLB) 229-1192	20	85	
	(SLB) 1-6, 192-228, 1193-1220	70	32	

Note1: Chip size included scribe line.

7.3. PAD Locations

PAD No.	PAD Name	X	Y
1	GND	-10012	-262
2	GND	-9922	-262
3	GND	-9832	-262
4	GND	-9742	-262
5	MODE1	-9652	-262
6	MODE0	-9562	-262
7	Dummy_GND_1	-9200	-243
8	Dummy_GND_2	-9100	-243
9	Dummy_GND_3	-9000	-243
10	Dummy_GND_4	-8900	-243
11	Dummy_GND_5	-8800	-243
12	Dummy_GND_6	-8700	-243
13	Dummy_GND_7	-8600	-243
14	Dummy_GND_8	-8500	-243
15	Dummy_GND_9	-8400	-243
16	Dummy_GND_10	-8300	-243
17	Dummy_GND_11	-8200	-243
18	Dummy_GND_12	-8100	-243
19	Dummy_GND_13	-8000	-243
20	Dummy_GND_14	-7900	-243
21	Dummy_GND_15	-7800	-243
22	Dummy_GND_16	-7700	-243
23	Dummy_GND_17	-7600	-243
24	Dummy_GND_18	-7500	-243
25	Dummy_GND_19	-7400	-243
26	Dummy_GND_20	-7300	-243
27	Dummy_GND_21	-7200	-243
28	Dummy_GND_22	-7100	-243
29	Dummy_GND_23	-7000	-243
30	Dummy_GND_24	-6900	-243
31	Dummy_GND_25	-6800	-243
32	Dummy_GND_26	-6700	-243
33	Dummy_GND_27	-6600	-243
34	Dummy_GND_28	-6500	-243
35	Dummy_GND_29	-6400	-243
36	Dummy_GND_30	-6300	-243
37	Dummy_GND_31	-6200	-243
38	Dummy_GND_32	-6100	-243
39	Dummy_GND_33	-6000	-243
40	Dummy_GND_34	-5900	-243
41	Dummy_GND_35	-5800	-243
42	Dummy_GND_36	-5700	-243
43	Dummy_GND_37	-5600	-243
44	Dummy_GND_38	-5500	-243
45	Dummy_GND_39	-5400	-243
46	Dummy_GND_40	-5300	-243
47	Dummy_GND_41	-5200	-243
48	Dummy_GND_42	-5100	-243
49	Dummy_GND_43	-5000	-243
50	Dummy_GND_44	-4900	-243
51	Dummy_GND_45	-4800	-243
52	Dummy_GND_46	-4700	-243
53	Dummy_GND_47	-4600	-243
54	Dummy_GND_48	-4500	-243
55	Dummy_GND_49	-4400	-243
56	Dummy_GND_50	-4300	-243
57	Dummy_GND_51	-4200	-243
58	Dummy_GND_52	-4100	-243
59	Dummy_GND_53	-4000	-243
60	Dummy_GND_54	-3900	-243
61	Dummy_GND_55	-3800	-243
62	Dummy_GND_56	-3700	-243
63	Dummy_GND_57	-3600	-243
64	Dummy_GND_58	-3500	-243
65	Dummy_GND_59	-3400	-243
66	Dummy_GND_60	-3300	-243

PAD No.	PAD Name	X	Y
67	Dummy_GND_61	-3200	-243
68	Dummy_GND_62	-3100	-243
69	Dummy_GND_63	-3000	-243
70	Dummy_GND_64	-2900	-243
71	Dummy_GND_65	-2800	-243
72	Dummy_GND_66	-2700	-243
73	Dummy_GND_67	-2600	-243
74	Dummy_GND_68	-2500	-243
75	Dummy_GND_69	-2400	-243
76	Dummy_GND_70	-2300	-243
77	Dummy_GND_71	-2200	-243
78	Dummy_GND_72	-2100	-243
79	Dummy_GND_73	-2000	-243
80	Dummy_GND_74	-1900	-243
81	Dummy_GND_75	-1800	-243
82	Dummy_GND_76	-1700	-243
83	Dummy_GND_77	-1600	-243
84	Dummy_GND_78	-1500	-243
85	Dummy_GND_79	-1400	-243
86	Dummy_GND_80	-1300	-243
87	Dummy_GND_81	-1200	-243
88	Dummy_GND_82	-1100	-243
89	Dummy_GND_83	-1000	-243
90	Dummy_GND_84	-900	-243
91	Dummy_GND_85	-800	-243
92	Dummy_GND_86	-700	-243
93	Dummy_GND_87	-600	-243
94	Dummy_GND_88	-500	-243
95	Dummy_GND_89	-400	-243
96	Dummy_GND_90	-300	-243
97	Dummy_GND_91	-200	-243
98	Dummy_GND_92	-100	-243
99	Dummy_GND_93	0	-243
100	Dummy_GND_94	100	-243
101	Dummy_GND_95	200	-243
102	Dummy_GND_96	300	-243
103	Dummy_GND_97	400	-243
104	Dummy_GND_98	500	-243
105	Dummy_GND_99	600	-243
106	Dummy_GND_100	700	-243
107	Dummy_GND_101	800	-243
108	Dummy_GND_102	900	-243
109	Dummy_GND_103	1000	-243
110	Dummy_GND_104	1100	-243
111	Dummy_GND_105	1200	-243
112	Dummy_GND_106	1300	-243
113	Dummy_GND_107	1400	-243
114	Dummy_GND_108	1500	-243
115	Dummy_GND_109	1600	-243
116	Dummy_GND_110	1700	-243
117	Dummy_GND_111	1800	-243
118	Dummy_GND_112	1900	-243
119	Dummy_GND_113	2000	-243
120	Dummy_GND_114	2100	-243
121	Dummy_GND_115	2200	-243
122	Dummy_GND_116	2300	-243
123	Dummy_GND_117	2400	-243
124	Dummy_GND_118	2500	-243
125	Dummy_GND_119	2600	-243
126	Dummy_GND_120	2700	-243
127	Dummy_GND_121	2800	-243
128	Dummy_GND_122	2900	-243
129	Dummy_GND_123	3000	-243
130	Dummy_GND_124	3100	-243
131	Dummy_GND_125	3200	-243
132	Dummy_GND_126	3300	-243

PAD No.	PAD Name	X	Y
133	Dummy_GND_127	3400	-243
134	Dummy_GND_128	3500	-243
135	Dummy_GND_129	3600	-243
136	Dummy_GND_130	3700	-243
137	Dummy_GND_131	3800	-243
138	Dummy_GND_132	3900	-243
139	Dummy_GND_133	4000	-243
140	Dummy_GND_134	4100	-243
141	Dummy_GND_135	4200	-243
142	Dummy_GND_136	4300	-243
143	Dummy_GND_137	4400	-243
144	Dummy_GND_138	4500	-243
145	Dummy_GND_139	4600	-243
146	Dummy_GND_140	4700	-243
147	Dummy_GND_141	4800	-243
148	Dummy_GND_142	4900	-243
149	Dummy_GND_143	5000	-243
150	Dummy_GND_144	5100	-243
151	Dummy_GND_145	5200	-243
152	Dummy_GND_146	5300	-243
153	Dummy_GND_147	5400	-243
154	Dummy_GND_148	5500	-243
155	Dummy_GND_149	5600	-243
156	Dummy_GND_150	5700	-243
157	Dummy_GND_151	5800	-243
158	Dummy_GND_152	5900	-243
159	Dummy_GND_153	6000	-243
160	Dummy_GND_154	6100	-243
161	Dummy_GND_155	6200	-243
162	Dummy_GND_156	6300	-243
163	Dummy_GND_157	6400	-243
164	Dummy_GND_158	6500	-243
165	Dummy_GND_159	6600	-243
166	Dummy_GND_160	6700	-243
167	Dummy_GND_161	6800	-243
168	Dummy_GND_162	6900	-243
169	Dummy_GND_163	7000	-243
170	Dummy_GND_164	7100	-243
171	Dummy_GND_165	7200	-243
172	Dummy_GND_166	7300	-243
173	Dummy_GND_167	7400	-243
174	Dummy_GND_168	7500	-243
175	Dummy_GND_169	7600	-243
176	Dummy_GND_170	7700	-243
177	Dummy_GND_171	7800	-243
178	Dummy_GND_172	7900	-243
179	Dummy_GND_173	8000	-243
180	Dummy_GND_174	8100	-243
181	Dummy_GND_175	8200	-243
182	Dummy_GND_176	8300	-243
183	Dummy_GND_177	8400	-243
184	Dummy_GND_178	8500	-243
185	Dummy_GND_179	8600	-243
186	Dummy_GND_180	8700	-243
187	Dummy_GND_181	8800	-243
188	Dummy_GND_182	8900	-243
189	Dummy_GND_183	9000	-243
190	Dummy_GND_184	9100	-243
191	Dummy_GND_185	9200	-243
192	MODE0	9562	-262
193	MODE1	9652	-262
194	GND	9742	-262
195	GND	9832	-262
196	GND	9922	-262
197	GND	10012	-262
198	VEE	9832	-208



PAD No.	PAD Name	X	Y
199	VEE	9922	-208
200	VEE	10012	-208
201	VCC	9832	-156
202	VCC	9922	-156
203	VCC	10012	-156
204	VGG	9832	-104
205	VGG	9922	-104
206	VGG	10012	-104
207	SEL	9832	-52
208	SEL	9922	-52
209	SEL	10012	-52
210	STVD	9832	0
211	STVD	9922	0
212	STVD	10012	0
213	PATH	9832	52
214	PATH	9922	52
215	PATH	10012	52
216	CLK	9832	104
217	CLK	9922	104
218	CLK	10012	104
219	U_D	9832	156
220	U_D	9922	156
221	U_D	10012	156
222	OE	9832	208
223	OE	9922	208
224	OE	10012	208
225	HSD	9922	262
226	HSD	10012	262
227	XOA	9742	262
228	XOA	9832	262
229	Dummy_VEE_2	9640	235.5
230	G0	9600	235.5
231	G1	9580	125.5
232	G2	9560	235.5
233	G3	9540	125.5
234	G4	9520	235.5
235	G5	9500	125.5
236	G6	9480	235.5
237	G7	9460	125.5
238	G8	9440	235.5
239	G9	9420	125.5
240	G10	9400	235.5
241	G11	9380	125.5
242	G12	9360	235.5
243	G13	9340	125.5
244	G14	9320	235.5
245	G15	9300	125.5
246	G16	9280	235.5
247	G17	9260	125.5
248	G18	9240	235.5
249	G19	9220	125.5
250	G20	9200	235.5
251	G21	9180	125.5
252	G22	9160	235.5
253	G23	9140	125.5
254	G24	9120	235.5
255	G25	9100	125.5
256	G26	9080	235.5
257	G27	9060	125.5
258	G28	9040	235.5
259	G29	9020	125.5
260	G30	9000	235.5
261	G31	8980	125.5
262	G32	8960	235.5
263	G33	8940	125.5
264	G34	8920	235.5
265	G35	8900	125.5

PAD No.	PAD Name	X	Y
266	G36	8880	235.5
267	G37	8860	125.5
268	G38	8840	235.5
269	G39	8820	125.5
270	G40	8800	235.5
271	G41	8780	125.5
272	G42	8760	235.5
273	G43	8740	125.5
274	G44	8720	235.5
275	G45	8700	125.5
276	G46	8680	235.5
277	G47	8660	125.5
278	G48	8640	235.5
279	G49	8620	125.5
280	G50	8600	235.5
281	G51	8580	125.5
282	G52	8560	235.5
283	G53	8540	125.5
284	G54	8520	235.5
285	G55	8500	125.5
286	G56	8480	235.5
287	G57	8460	125.5
288	G58	8440	235.5
289	G59	8420	125.5
290	G60	8400	235.5
291	G61	8380	125.5
292	G62	8360	235.5
293	G63	8340	125.5
294	G64	8320	235.5
295	G65	8300	125.5
296	G66	8280	235.5
297	G67	8260	125.5
298	G68	8240	235.5
299	G69	8220	125.5
300	G70	8200	235.5
301	G71	8180	125.5
302	G72	8160	235.5
303	G73	8140	125.5
304	G74	8120	235.5
305	G75	8100	125.5
306	G76	8080	235.5
307	G77	8060	125.5
308	G78	8040	235.5
309	G79	8020	125.5
310	G80	8000	235.5
311	G81	7980	125.5
312	G82	7960	235.5
313	G83	7940	125.5
314	G84	7920	235.5
315	G85	7900	125.5
316	G86	7880	235.5
317	G87	7860	125.5
318	G88	7840	235.5
319	G89	7820	125.5
320	G90	7800	235.5
321	G91	7780	125.5
322	G92	7760	235.5
323	G93	7740	125.5
324	G94	7720	235.5
325	G95	7700	125.5
326	G96	7680	235.5
327	G97	7660	125.5
328	G98	7640	235.5
329	G99	7620	125.5
330	G100	7600	235.5
331	G101	7580	125.5
332	G102	7560	235.5

PAD No.	PAD Name	X	Y
333	G103	7540	125.5
334	G104	7520	235.5
335	G105	7500	125.5
336	G106	7480	235.5
337	G107	7460	125.5
338	G108	7440	235.5
339	G109	7420	125.5
340	G110	7400	235.5
341	G111	7380	125.5
342	G112	7360	235.5
343	G113	7340	125.5
344	G114	7320	235.5
345	G115	7300	125.5
346	G116	7280	235.5
347	G117	7260	125.5
348	G118	7240	235.5
349	G119	7220	125.5
350	G120	7200	235.5
351	G121	7180	125.5
352	G122	7160	235.5
353	G123	7140	125.5
354	G124	7120	235.5
355	G125	7100	125.5
356	G126	7080	235.5
357	G127	7060	125.5
358	G128	7040	235.5
359	G129	7020	125.5
360	G130	7000	235.5
361	G131	6980	125.5
362	G132	6960	235.5
363	G133	6940	125.5
364	G134	6920	235.5
365	G135	6900	125.5
366	G136	6880	235.5
367	G137	6860	125.5
368	G138	6840	235.5
369	G139	6820	125.5
370	G140	6800	235.5
371	G141	6780	125.5
372	G142	6760	235.5
373	G143	6740	125.5
374	G144	6720	235.5
375	G145	6700	125.5
376	G146	6680	235.5
377	G147	6660	125.5
378	G148	6640	235.5
379	G149	6620	125.5
380	G150	6600	235.5
381	G151	6580	125.5
382	G152	6560	235.5
383	G153	6540	125.5
384	G154	6520	235.5
385	G155	6500	125.5
386	G156	6480	235.5
387	G157	6460	125.5
388	G158	6440	235.5
389	G159	6420	125.5
390	G160	6400	235.5
391	G161	6380	125.5
392	G162	6360	235.5
393	G163	6340	125.5
394	G164	6320	235.5
395	G165	6300	125.5
396	G166	6280	235.5
397	G167	6260	125.5
398	G168	6240	235.5
399	G169	6220	125.5



PAD No.	PAD Name	X	Y
400	G170	6200	235.5
401	G171	6180	125.5
402	G172	6160	235.5
403	G173	6140	125.5
404	G174	6120	235.5
405	G175	6100	125.5
406	G176	6080	235.5
407	G177	6060	125.5
408	G178	6040	235.5
409	G179	6020	125.5
410	G180	6000	235.5
411	G181	5980	125.5
412	G182	5960	235.5
413	G183	5940	125.5
414	G184	5920	235.5
415	G185	5900	125.5
416	G186	5880	235.5
417	G187	5860	125.5
418	G188	5840	235.5
419	G189	5820	125.5
420	G190	5800	235.5
421	G191	5780	125.5
422	G192	5760	235.5
423	G193	5740	125.5
424	G194	5720	235.5
425	G195	5700	125.5
426	G196	5680	235.5
427	G197	5660	125.5
428	G198	5640	235.5
429	G199	5620	125.5
430	G200	5600	235.5
431	G201	5580	125.5
432	G202	5560	235.5
433	G203	5540	125.5
434	G204	5520	235.5
435	G205	5500	125.5
436	G206	5480	235.5
437	G207	5460	125.5
438	G208	5440	235.5
439	G209	5420	125.5
440	G210	5400	235.5
441	G211	5380	125.5
442	G212	5360	235.5
443	G213	5340	125.5
444	G214	5320	235.5
445	G215	5300	125.5
446	G216	5280	235.5
447	G217	5260	125.5
448	G218	5240	235.5
449	G219	5220	125.5
450	G220	5200	235.5
451	G221	5180	125.5
452	G222	5160	235.5
453	G223	5140	125.5
454	G224	5120	235.5
455	G225	5100	125.5
456	G226	5080	235.5
457	G227	5060	125.5
458	G228	5040	235.5
459	G229	5020	125.5
460	G230	5000	235.5
461	G231	4980	125.5
462	G232	4960	235.5
463	G233	4940	125.5
464	G234	4920	235.5
465	G235	4900	125.5
466	G236	4880	235.5

PAD No.	PAD Name	X	Y
467	G237	4860	125.5
468	G238	4840	235.5
469	G239	4820	125.5
470	G240	4800	235.5
471	G241	4780	125.5
472	G242	4760	235.5
473	G243	4740	125.5
474	G244	4720	235.5
475	G245	4700	125.5
476	G246	4680	235.5
477	G247	4660	125.5
478	G248	4640	235.5
479	G249	4620	125.5
480	G250	4600	235.5
481	G251	4580	125.5
482	G252	4560	235.5
483	G253	4540	125.5
484	G254	4520	235.5
485	G255	4500	125.5
486	G256	4480	235.5
487	G257	4460	125.5
488	G258	4440	235.5
489	G259	4420	125.5
490	G260	4400	235.5
491	G261	4380	125.5
492	G262	4360	235.5
493	G263	4340	125.5
494	G264	4320	235.5
495	G265	4300	125.5
496	G266	4280	235.5
497	G267	4260	125.5
498	G268	4240	235.5
499	G269	4220	125.5
500	G270	4200	235.5
501	G271	4180	125.5
502	G272	4160	235.5
503	G273	4140	125.5
504	G274	4120	235.5
505	G275	4100	125.5
506	G276	4080	235.5
507	G277	4060	125.5
508	G278	4040	235.5
509	G279	4020	125.5
510	G280	4000	235.5
511	G281	3980	125.5
512	G282	3960	235.5
513	G283	3940	125.5
514	G284	3920	235.5
515	G285	3900	125.5
516	G286	3880	235.5
517	G287	3860	125.5
518	G288	3840	235.5
519	G289	3820	125.5
520	G290	3800	235.5
521	G291	3780	125.5
522	G292	3760	235.5
523	G293	3740	125.5
524	G294	3720	235.5
525	G295	3700	125.5
526	G296	3680	235.5
527	G297	3660	125.5
528	G298	3640	235.5
529	G299	3620	125.5
530	G300	3600	235.5
531	G301	3580	125.5
532	G302	3560	235.5
533	G303	3540	125.5

PAD No.	PAD Name	X	Y
534	G304	3520	235.5
535	G305	3500	125.5
536	G306	3480	235.5
537	G307	3460	125.5
538	G308	3440	235.5
539	G309	3420	125.5
540	G310	3400	235.5
541	G311	3380	125.5
542	G312	3360	235.5
543	G313	3340	125.5
544	G314	3320	235.5
545	G315	3300	125.5
546	G316	3280	235.5
547	G317	3260	125.5
548	G318	3240	235.5
549	G319	3220	125.5
550	G320	3200	235.5
551	G321	3180	125.5
552	G322	3160	235.5
553	G323	3140	125.5
554	G324	3120	235.5
555	G325	3100	125.5
556	G326	3080	235.5
557	G327	3060	125.5
558	G328	3040	235.5
559	G329	3020	125.5
560	G330	3000	235.5
561	G331	2980	125.5
562	G332	2960	235.5
563	G333	2940	125.5
564	G334	2920	235.5
565	G335	2900	125.5
566	G336	2880	235.5
567	G337	2860	125.5
568	G338	2840	235.5
569	G339	2820	125.5
570	G340	2800	235.5
571	G341	2780	125.5
572	G342	2760	235.5
573	G343	2740	125.5
574	G344	2720	235.5
575	G345	2700	125.5
576	G346	2680	235.5
577	G347	2660	125.5
578	G348	2640	235.5
579	G349	2620	125.5
580	G350	2600	235.5
581	G351	2580	125.5
582	G352	2560	235.5
583	G353	2540	125.5
584	G354	2520	235.5
585	G355	2500	125.5
586	G356	2480	235.5
587	G357	2460	125.5
588	G358	2440	235.5
589	G359	2420	125.5
590	G360	2400	235.5
591	G361	2380	125.5
592	G362	2360	235.5
593	G363	2340	125.5
594	G364	2320	235.5
595	G365	2300	125.5
596	G366	2280	235.5
597	G367	2260	125.5
598	G368	2240	235.5
599	G369	2220	125.5
600	G370	2200	235.5

PAD No.	PAD Name	X	Y
601	G371	2180	125.5
602	G372	2160	235.5
603	G373	2140	125.5
604	G374	2120	235.5
605	G375	2100	125.5
606	G376	2080	235.5
607	G377	2060	125.5
608	G378	2040	235.5
609	G379	2020	125.5
610	G380	2000	235.5
611	G381	1980	125.5
612	G382	1960	235.5
613	G383	1940	125.5
614	G384	1920	235.5
615	G385	1900	125.5
616	G386	1880	235.5
617	G387	1860	125.5
618	G388	1840	235.5
619	G389	1820	125.5
620	G390	1800	235.5
621	G391	1780	125.5
622	G392	1760	235.5
623	G393	1740	125.5
624	G394	1720	235.5
625	G395	1700	125.5
626	G396	1680	235.5
627	G397	1660	125.5
628	G398	1640	235.5
629	G399	1620	125.5
630	G400	1600	235.5
631	G401	1580	125.5
632	G402	1560	235.5
633	G403	1540	125.5
634	G404	1520	235.5
635	G405	1500	125.5
636	G406	1480	235.5
637	G407	1460	125.5
638	G408	1440	235.5
639	G409	1420	125.5
640	G410	1400	235.5
641	G411	1380	125.5
642	G412	1360	235.5
643	G413	1340	125.5
644	G414	1320	235.5
645	G415	1300	125.5
646	G416	1280	235.5
647	G417	1260	125.5
648	G418	1240	235.5
649	G419	1220	125.5
650	G420	1200	235.5
651	G421	1180	125.5
652	G422	1160	235.5
653	G423	1140	125.5
654	G424	1120	235.5
655	G425	1100	125.5
656	G426	1080	235.5
657	G427	1060	125.5
658	G428	1040	235.5
659	G429	1020	125.5
660	G430	1000	235.5
661	G431	980	125.5
662	G432	960	235.5
663	G433	940	125.5
664	G434	920	235.5
665	G435	900	125.5
666	G436	880	235.5
667	G437	860	125.5

PAD No.	PAD Name	X	Y
668	G438	840	235.5
669	G439	820	125.5
670	G440	800	235.5
671	G441	780	125.5
672	G442	760	235.5
673	G443	740	125.5
674	G444	720	235.5
675	G445	700	125.5
676	G446	680	235.5
677	G447	660	125.5
678	G448	640	235.5
679	G449	620	125.5
680	G450	600	235.5
681	G451	580	125.5
682	G452	560	235.5
683	G453	540	125.5
684	G454	520	235.5
685	G455	500	125.5
686	G456	480	235.5
687	G457	460	125.5
688	G458	440	235.5
689	G459	420	125.5
690	G460	400	235.5
691	G461	380	125.5
692	G462	360	235.5
693	G463	340	125.5
694	G464	320	235.5
695	G465	300	125.5
696	G466	280	235.5
697	G467	260	125.5
698	G468	240	235.5
699	G469	220	125.5
700	G470	200	235.5
701	G471	180	125.5
702	G472	160	235.5
703	G473	140	125.5
704	G474	120	235.5
705	G475	100	125.5
706	G476	80	235.5
707	G477	60	125.5
708	G478	40	235.5
709	G479	20	125.5
710	G480	0	235.5
711	G481	-20	125.5
712	G482	-40	235.5
713	G483	-60	125.5
714	G484	-80	235.5
715	G485	-100	125.5
716	G486	-120	235.5
717	G487	-140	125.5
718	G488	-160	235.5
719	G489	-180	125.5
720	G490	-200	235.5
721	G491	-220	125.5
722	G492	-240	235.5
723	G493	-260	125.5
724	G494	-280	235.5
725	G495	-300	125.5
726	G496	-320	235.5
727	G497	-340	125.5
728	G498	-360	235.5
729	G499	-380	125.5
730	G500	-400	235.5
731	G501	-420	125.5
732	G502	-440	235.5
733	G503	-460	125.5
734	G504	-480	235.5

PAD No.	PAD Name	X	Y
735	G505	-500	125.5
736	G506	-520	235.5
737	G507	-540	125.5
738	G508	-560	235.5
739	G509	-580	125.5
740	G510	-600	235.5
741	G511	-620	125.5
742	G512	-640	235.5
743	G513	-660	125.5
744	G514	-680	235.5
745	G515	-700	125.5
746	G516	-720	235.5
747	G517	-740	125.5
748	G518	-760	235.5
749	G519	-780	125.5
750	G520	-800	235.5
751	G521	-820	125.5
752	G522	-840	235.5
753	G523	-860	125.5
754	G524	-880	235.5
755	G525	-900	125.5
756	G526	-920	235.5
757	G527	-940	125.5
758	G528	-960	235.5
759	G529	-980	125.5
760	G530	-1000	235.5
761	G531	-1020	125.5
762	G532	-1040	235.5
763	G533	-1060	125.5
764	G534	-1080	235.5
765	G535	-1100	125.5
766	G536	-1120	235.5
767	G537	-1140	125.5
768	G538	-1160	235.5
769	G539	-1180	125.5
770	G540	-1200	235.5
771	G541	-1220	125.5
772	G542	-1240	235.5
773	G543	-1260	125.5
774	G544	-1280	235.5
775	G545	-1300	125.5
776	G546	-1320	235.5
777	G547	-1340	125.5
778	G548	-1360	235.5
779	G549	-1380	125.5
780	G550	-1400	235.5
781	G551	-1420	125.5
782	G552	-1440	235.5
783	G553	-1460	125.5
784	G554	-1480	235.5
785	G555	-1500	125.5
786	G556	-1520	235.5
787	G557	-1540	125.5
788	G558	-1560	235.5
789	G559	-1580	125.5
790	G560	-1600	235.5
791	G561	-1620	125.5
792	G562	-1640	235.5
793	G563	-1660	125.5
794	G564	-1680	235.5
795	G565	-1700	125.5
796	G566	-1720	235.5
797	G567	-1740	125.5
798	G568	-1760	235.5
799	G569	-1780	125.5
800	G570	-1800	235.5
801	G571	-1820	125.5



PAD No.	PAD Name	X	Y
802	G572	-1840	235.5
803	G573	-1860	125.5
804	G574	-1880	235.5
805	G575	-1900	125.5
806	G576	-1920	235.5
807	G577	-1940	125.5
808	G578	-1960	235.5
809	G579	-1980	125.5
810	G580	-2000	235.5
811	G581	-2020	125.5
812	G582	-2040	235.5
813	G583	-2060	125.5
814	G584	-2080	235.5
815	G585	-2100	125.5
816	G586	-2120	235.5
817	G587	-2140	125.5
818	G588	-2160	235.5
819	G589	-2180	125.5
820	G590	-2200	235.5
821	G591	-2220	125.5
822	G592	-2240	235.5
823	G593	-2260	125.5
824	G594	-2280	235.5
825	G595	-2300	125.5
826	G596	-2320	235.5
827	G597	-2340	125.5
828	G598	-2360	235.5
829	G599	-2380	125.5
830	G600	-2400	235.5
831	G601	-2420	125.5
832	G602	-2440	235.5
833	G603	-2460	125.5
834	G604	-2480	235.5
835	G605	-2500	125.5
836	G606	-2520	235.5
837	G607	-2540	125.5
838	G608	-2560	235.5
839	G609	-2580	125.5
840	G610	-2600	235.5
841	G611	-2620	125.5
842	G612	-2640	235.5
843	G613	-2660	125.5
844	G614	-2680	235.5
845	G615	-2700	125.5
846	G616	-2720	235.5
847	G617	-2740	125.5
848	G618	-2760	235.5
849	G619	-2780	125.5
850	G620	-2800	235.5
851	G621	-2820	125.5
852	G622	-2840	235.5
853	G623	-2860	125.5
854	G624	-2880	235.5
855	G625	-2900	125.5
856	G626	-2920	235.5
857	G627	-2940	125.5
858	G628	-2960	235.5
859	G629	-2980	125.5
860	G630	-3000	235.5
861	G631	-3020	125.5
862	G632	-3040	235.5
863	G633	-3060	125.5
864	G634	-3080	235.5
865	G635	-3100	125.5
866	G636	-3120	235.5
867	G637	-3140	125.5
868	G638	-3160	235.5

PAD No.	PAD Name	X	Y
869	G639	-3180	125.5
870	G640	-3200	235.5
871	G641	-3220	125.5
872	G642	-3240	235.5
873	G643	-3260	125.5
874	G644	-3280	235.5
875	G645	-3300	125.5
876	G646	-3320	235.5
877	G647	-3340	125.5
878	G648	-3360	235.5
879	G649	-3380	125.5
880	G650	-3400	235.5
881	G651	-3420	125.5
882	G652	-3440	235.5
883	G653	-3460	125.5
884	G654	-3480	235.5
885	G655	-3500	125.5
886	G656	-3520	235.5
887	G657	-3540	125.5
888	G658	-3560	235.5
889	G659	-3580	125.5
890	G660	-3600	235.5
891	G661	-3620	125.5
892	G662	-3640	235.5
893	G663	-3660	125.5
894	G664	-3680	235.5
895	G665	-3700	125.5
896	G666	-3720	235.5
897	G667	-3740	125.5
898	G668	-3760	235.5
899	G669	-3780	125.5
900	G670	-3800	235.5
901	G671	-3820	125.5
902	G672	-3840	235.5
903	G673	-3860	125.5
904	G674	-3880	235.5
905	G675	-3900	125.5
906	G676	-3920	235.5
907	G677	-3940	125.5
908	G678	-3960	235.5
909	G679	-3980	125.5
910	G680	-4000	235.5
911	G681	-4020	125.5
912	G682	-4040	235.5
913	G683	-4060	125.5
914	G684	-4080	235.5
915	G685	-4100	125.5
916	G686	-4120	235.5
917	G687	-4140	125.5
918	G688	-4160	235.5
919	G689	-4180	125.5
920	G690	-4200	235.5
921	G691	-4220	125.5
922	G692	-4240	235.5
923	G693	-4260	125.5
924	G694	-4280	235.5
925	G695	-4300	125.5
926	G696	-4320	235.5
927	G697	-4340	125.5
928	G698	-4360	235.5
929	G699	-4380	125.5
930	G700	-4400	235.5
931	G701	-4420	125.5
932	G702	-4440	235.5
933	G703	-4460	125.5
934	G704	-4480	235.5
935	G705	-4500	125.5

PAD No.	PAD Name	X	Y
936	G706	-4520	235.5
937	G707	-4540	125.5
938	G708	-4560	235.5
939	G709	-4580	125.5
940	G710	-4600	235.5
941	G711	-4620	125.5
942	G712	-4640	235.5
943	G713	-4660	125.5
944	G714	-4680	235.5
945	G715	-4700	125.5
946	G716	-4720	235.5
947	G717	-4740	125.5
948	G718	-4760	235.5
949	G719	-4780	125.5
950	G720	-4800	235.5
951	G721	-4820	125.5
952	G722	-4840	235.5
953	G723	-4860	125.5
954	G724	-4880	235.5
955	G725	-4900	125.5
956	G726	-4920	235.5
957	G727	-4940	125.5
958	G728	-4960	235.5
959	G729	-4980	125.5
960	G730	-5000	235.5
961	G731	-5020	125.5
962	G732	-5040	235.5
963	G733	-5060	125.5
964	G734	-5080	235.5
965	G735	-5100	125.5
966	G736	-5120	235.5
967	G737	-5140	125.5
968	G738	-5160	235.5
969	G739	-5180	125.5
970	G740	-5200	235.5
971	G741	-5220	125.5
972	G742	-5240	235.5
973	G743	-5260	125.5
974	G744	-5280	235.5
975	G745	-5300	125.5
976	G746	-5320	235.5
977	G747	-5340	125.5
978	G748	-5360	235.5
979	G749	-5380	125.5
980	G750	-5400	235.5
981	G751	-5420	125.5
982	G752	-5440	235.5
983	G753	-5460	125.5
984	G754	-5480	235.5
985	G755	-5500	125.5
986	G756	-5520	235.5
987	G757	-5540	125.5
988	G758	-5560	235.5
989	G759	-5580	125.5
990	G760	-5600	235.5
991	G761	-5620	125.5
992	G762	-5640	235.5
993	G763	-5660	125.5
994	G764	-5680	235.5
995	G765	-5700	125.5
996	G766	-5720	235.5
997	G767	-5740	125.5
998	G768	-5760	235.5
999	G769	-5780	125.5
1000	G770	-5800	235.5
1001	G771	-5820	125.5
1002	G772	-5840	235.5



Preliminary
OTD9960A

PAD No.	PAD Name	X	Y
1003	G773	-5860	125.5
1004	G774	-5880	235.5
1005	G775	-5900	125.5
1006	G776	-5920	235.5
1007	G777	-5940	125.5
1008	G778	-5960	235.5
1009	G779	-5980	125.5
1010	G780	-6000	235.5
1011	G781	-6020	125.5
1012	G782	-6040	235.5
1013	G783	-6060	125.5
1014	G784	-6080	235.5
1015	G785	-6100	125.5
1016	G786	-6120	235.5
1017	G787	-6140	125.5
1018	G788	-6160	235.5
1019	G789	-6180	125.5
1020	G790	-6200	235.5
1021	G791	-6220	125.5
1022	G792	-6240	235.5
1023	G793	-6260	125.5
1024	G794	-6280	235.5
1025	G795	-6300	125.5
1026	G796	-6320	235.5
1027	G797	-6340	125.5
1028	G798	-6360	235.5
1029	G799	-6380	125.5
1030	G800	-6400	235.5
1031	G801	-6420	125.5
1032	G802	-6440	235.5
1033	G803	-6460	125.5
1034	G804	-6480	235.5
1035	G805	-6500	125.5
1036	G806	-6520	235.5
1037	G807	-6540	125.5
1038	G808	-6560	235.5
1039	G809	-6580	125.5
1040	G810	-6600	235.5
1041	G811	-6620	125.5
1042	G812	-6640	235.5
1043	G813	-6660	125.5
1044	G814	-6680	235.5
1045	G815	-6700	125.5
1046	G816	-6720	235.5
1047	G817	-6740	125.5
1048	G818	-6760	235.5
1049	G819	-6780	125.5
1050	G820	-6800	235.5
1051	G821	-6820	125.5
1052	G822	-6840	235.5
1053	G823	-6860	125.5
1054	G824	-6880	235.5
1055	G825	-6900	125.5
1056	G826	-6920	235.5
1057	G827	-6940	125.5
1058	G828	-6960	235.5
1059	G829	-6980	125.5
1060	G830	-7000	235.5
1061	G831	-7020	125.5
1062	G832	-7040	235.5
1063	G833	-7060	125.5
1064	G834	-7080	235.5
1065	G835	-7100	125.5
1066	G836	-7120	235.5
1067	G837	-7140	125.5
1068	G838	-7160	235.5
1069	G839	-7180	125.5

PAD No.	PAD Name	X	Y
1070	G840	-7200	235.5
1071	G841	-7220	125.5
1072	G842	-7240	235.5
1073	G843	-7260	125.5
1074	G844	-7280	235.5
1075	G845	-7300	125.5
1076	G846	-7320	235.5
1077	G847	-7340	125.5
1078	G848	-7360	235.5
1079	G849	-7380	125.5
1080	G850	-7400	235.5
1081	G851	-7420	125.5
1082	G852	-7440	235.5
1083	G853	-7460	125.5
1084	G854	-7480	235.5
1085	G855	-7500	125.5
1086	G856	-7520	235.5
1087	G857	-7540	125.5
1088	G858	-7560	235.5
1089	G859	-7580	125.5
1090	G860	-7600	235.5
1091	G861	-7620	125.5
1092	G862	-7640	235.5
1093	G863	-7660	125.5
1094	G864	-7680	235.5
1095	G865	-7700	125.5
1096	G866	-7720	235.5
1097	G867	-7740	125.5
1098	G868	-7760	235.5
1099	G869	-7780	125.5
1100	G870	-7800	235.5
1101	G871	-7820	125.5
1102	G872	-7840	235.5
1103	G873	-7860	125.5
1104	G874	-7880	235.5
1105	G875	-7900	125.5
1106	G876	-7920	235.5
1107	G877	-7940	125.5
1108	G878	-7960	235.5
1109	G879	-7980	125.5
1110	G880	-8000	235.5
1111	G881	-8020	125.5
1112	G882	-8040	235.5
1113	G883	-8060	125.5
1114	G884	-8080	235.5
1115	G885	-8100	125.5
1116	G886	-8120	235.5
1117	G887	-8140	125.5
1118	G888	-8160	235.5
1119	G889	-8180	125.5
1120	G890	-8200	235.5
1121	G891	-8220	125.5
1122	G892	-8240	235.5
1123	G893	-8260	125.5
1124	G894	-8280	235.5
1125	G895	-8300	125.5
1126	G896	-8320	235.5
1127	G897	-8340	125.5
1128	G898	-8360	235.5
1129	G899	-8380	125.5
1130	G900	-8400	235.5
1131	G901	-8420	125.5
1132	G902	-8440	235.5
1133	G903	-8460	125.5
1134	G904	-8480	235.5
1135	G905	-8500	125.5
1136	G906	-8520	235.5

PAD No.	PAD Name	X	Y
1137	G907	-8540	125.5
1138	G908	-8560	235.5
1139	G909	-8580	125.5
1140	G910	-8600	235.5
1141	G911	-8620	125.5
1142	G912	-8640	235.5
1143	G913	-8660	125.5
1144	G914	-8680	235.5
1145	G915	-8700	125.5
1146	G916	-8720	235.5
1147	G917	-8740	125.5
1148	G918	-8760	235.5
1149	G919	-8780	125.5
1150	G920	-8800	235.5
1151	G921	-8820	125.5
1152	G922	-8840	235.5
1153	G923	-8860	125.5
1154	G924	-8880	235.5
1155	G925	-8900	125.5
1156	G926	-8920	235.5
1157	G927	-8940	125.5
1158	G928	-8960	235.5
1159	G929	-8980	125.5
1160	G930	-9000	235.5
1161	G931	-9020	125.5
1162	G932	-9040	235.5
1163	G933	-9060	125.5
1164	G934	-9080	235.5
1165	G935	-9100	125.5
1166	G936	-9120	235.5
1167	G937	-9140	125.5
1168	G938	-9160	235.5
1169	G939	-9180	125.5
1170	G940	-9200	235.5
1171	G941	-9220	125.5
1172	G942	-9240	235.5
1173	G943	-9260	125.5
1174	G944	-9280	235.5
1175	G945	-9300	125.5
1176	G946	-9320	235.5
1177	G947	-9340	125.5
1178	G948	-9360	235.5
1179	G949	-9380	125.5
1180	G950	-9400	235.5
1181	G951	-9420	125.5
1182	G952	-9440	235.5
1183	G953	-9460	125.5
1184	G954	-9480	235.5
1185	G955	-9500	125.5
1186	G956	-9520	235.5
1187	G957	-9540	125.5
1188	G958	-9560	235.5
1189	G959	-9580	125.5
1190	G960	-9600	235.5
1191	G961	-9620	125.5
1192	Dummy_VEE_2	-9640	235.5
1193	XOA	-9742	262
1194	XOA	-9832	262
1195	HSD	-9922	262
1196	HSD	-10012	262
1197	OE	-9832	208
1198	OE	-9922	208
1199	OE	-10012	208
1200	U_D	-9832	156
1201	U_D	-9922	156
1202	U_D	-10012	156
1203	CLK	-9832	104

PAD No.	PAD Name	X	Y
1204	CLK	-9922	104
1205	CLK	-10012	104
1206	PATH	-9832	52
1207	PATH	-9922	52
1208	PATH	-10012	52
1209	STVU	-9832	0
1210	STVU	-9922	0
1211	STVU	-10012	0

PAD No.	PAD Name	X	Y
1212	SEL	-9832	-52
1213	SEL	-9922	-52
1214	SEL	-10012	-52
1215	VGG	-9832	-104
1216	VGG	-9922	-104
1217	VGG	-10012	-104
1218	VCC	-9832	-156
1219	VCC	-9922	-156

PAD No.	PAD Name	X	Y
1220	VCC	-10012	-156
1221	VEE	-9832	-208
1222	VEE	-9922	-208
1223	VEE	-10012	-208

7.4. Alignment Mark

--Alignment Mark coordinate

Left (-9383.5, -220.5)

Right (9383.5, -220.5)

--Alignment Mark size

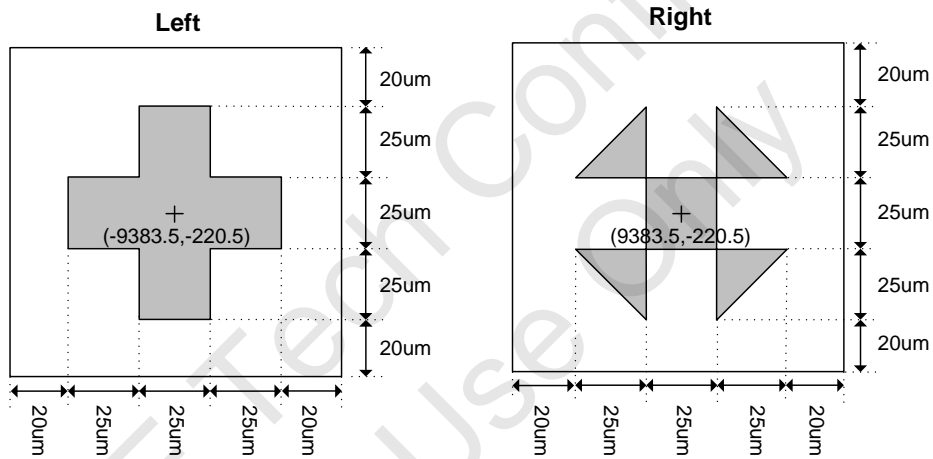

8. DISCLAIMER

The information appearing in this publication is believed to be accurate.

Integrated circuits sold by ORISE Technology are covered by the warranty and patent indemnification provisions stipulated in the terms of sale only. ORISE Technology makes no warranty, express, statutory implied or by description regarding the information in this publication or regarding the freedom of the described chip(s) from patent infringement. FURTHERMORE, ORISE Technology MAKES NO WARRANTY OF MERCHANTABILITY OR FITNESS FOR ANY PURPOSE. ORISE Technology reserves the right to halt production or alter the specifications and prices at any time without notice. Accordingly, the reader is cautioned to verify that the data sheets and other information in this publication are current before placing orders. Products described herein are intended for use in normal commercial applications. Applications involving unusual environmental or reliability requirements, e.g. military equipment or medical life support equipment, are specifically not recommended without additional processing by ORISE Technology for such applications. Please note that application circuits illustrated in this document are for reference purposes only.

ORISE Tech Confidential
For 眾毅 Use Only

9. REVISION HISTORY

Date	Revision #	Description	Page
JAN. 26, 2011	0.3	Update Channel Mode Selection	4
NOV. 18, 2010	0.2	Update Pad Location	15
JUL. 07, 2010	0.1	Original	22

ORISE Tech Confidential
For 眾教 Use Only