



## NT3882

### Dot Matrix LCD 40-Channel Driver

#### Features

- Provides a 40 channel LCD driver
- Internal serial to parallel conversion circuits:
  - 20-bit shift register X 2
  - 40-bit latch X 1
  - 40-bit 4 level driver X 1
- Logic circuit supply voltage range: 4.5V - 5.5V
- LCD driving voltage range ( $V_{DD} - V_{EE}$ ): 3.5V to 11V
- Applicable LCD duty cycle: 1/2 to 1/16
- Interfaces with a NT3881C/D LCD controller
- LCD bias voltage can be supplied externally
- Available in 64-pin QFP and in CHIP FORM

#### General Description

The NT3882 is a dot matrix LCD 40 channel driver fabricated by low power CMOS technology. This IC consists of two 20-bit shift registers, a 40-bit latch, and a 40-bit 4 level LCD driver. The NT3882 converts serial data which is received from the LCD controller

(NT3881C/D) to parallel data and then outputs LCD driving waveforms to drive LCD. Expansion of character-type liquid crystal display can be easily obtained according to the number and structure of characters.

#### Pin Configuration

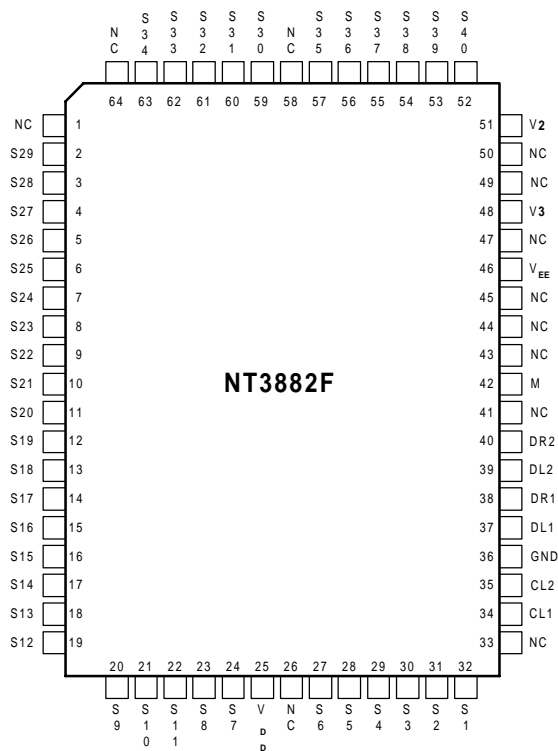

#### Pad Configuration

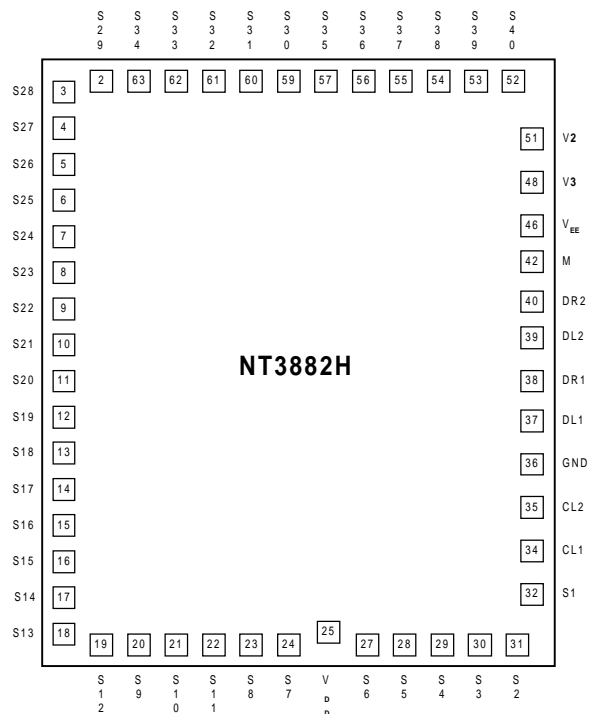

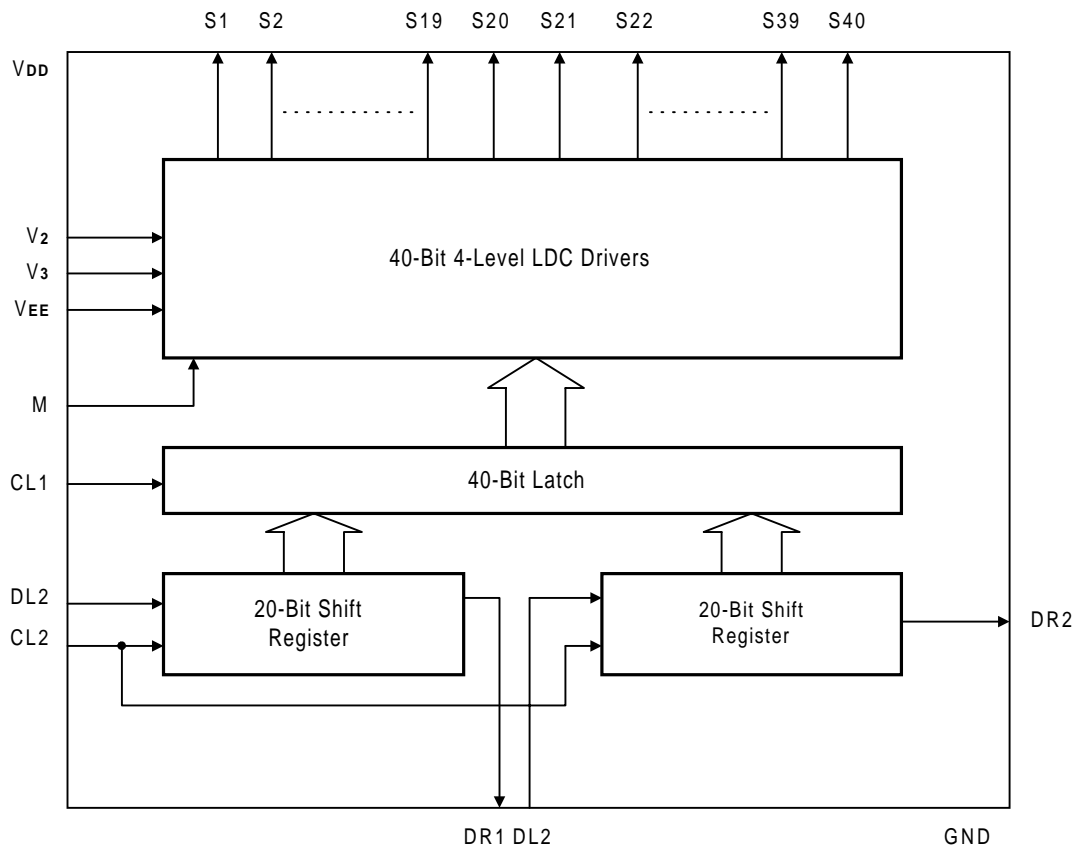
**Block Diagram**

**Pin and Pad Descriptions**

Pin No.	Pad No.	Designation	I/O	External Connection	Description
2- 24, 27 - 32, 52 - 57, 59 - 63	27 - 32, 2 - 24, 52 - 57, 59 - 63	S29 - S7, S6 - S1, S40 - S35, S30 - S34	O	LCD panel	Segment signal output pins
25	25	V <sub>DD</sub>	P	Power supply	Power for logic circuits
34	34	CL1	I	Controller	Clock to latch serial data
35	35	CL2	I	Controller	Clock to shift serial data
36	36	GND	P	Power Supply	0V
37	37	DL1	I	Controller or NT3882	Data input of 1 - 20 bits from controller
38	38	DR1	O	NT3882	Data output of 20 bit shift register
39	39	DL2	I	Controller or NT3882	Data input of 21 - 40 bits from controller
40	40	DR2	O	NT3882	Data output of 40 bit shift register
42	42	M	I	Controller	Alternate signal for LCD drivers
46, 48, 51	46, 48, 51	V <sub>EE</sub> , V <sub>3</sub> , V <sub>2</sub>	P	Power Supply	Power for LCD drivers
1, 26, 33, 41, 43 - 45, 47, 49, 50, 58, 64	-	NC	-	-	No connection

**Functional Description**

NT3882 is a dot matrix LCD segment driver LSI. It operates with the controller, such as NT3881C/D, and/or another segment driver LSI NT3882. NT3882 receives serial data from the controller or another NT3882, converts it to parallel data and then supplies the LCD driving waveforms to the LCD panel.

**1. CL1**

This signal is used for latching the shift register contents. When CL1 is set at high, the shift register contents are transferred to the 40-bit 4level LCD driver. When CL1 is set at low, the last display output data (S1 to S40) is held.

**2. CL2**

Clock pulse inputs for the two 20-bit shift registers. The data is shifted to a 40-bit latch at the falling edge of CL2. The clock signal CL2 must be active when operating to refresh shift registers' contents.

**3. DL1**

The 1 - 20 bit data from LCD controller is fed into the first 20-bit shift register through DL1.

**4. DR1**

The 20th bit data of first 20-bit shift register output from DR1. The data shifted out from DR1 after 20 bit delay are synchronized with the clock pulse (CL2). By connecting DR1 to DL2, two 20-bit shift registers can be cascaded to one 40-bit shift register.

**5. DL2**

The 21 - 40 bit data from the LCD controller is fed into the second 20-bit shift register through DL2.

**6. DR2**

The 40th bit data of the second 20-bit shift register output is from DR2. The data shifted out from DR2 after a 20-bit delay is synchronized with the clock pulse (CL2). By connecting DR2 to the next NT3882 DL1, the cascade construction is obtained to drive a wider LCD panel.

**7. S1 to S40**

These 40 bits represent the 40 data bits in the 40-bit latch. One of V<sub>DD</sub>, V<sub>2</sub>, V<sub>3</sub> and V<sub>EE</sub> is selected as a LCD driving voltage source according to the combination of latched data level and the alternate signal (M).

The truth table is listed as follows:

Latched Data	M	Output level of S1 to S40
1(High)	1(High)	$V_{EE}$
(Selected)	0(Low)	$V_{DD}$
0(Low)	1(High)	$V_3$
(Nonselected)	0(Low)	$V_2$

**Absolute Maximum Ratings\***

Power Supply Voltage ( $V_{DD}$ -GND) . . . . . -0.3V to 7.0V  
 Power Supply Voltage ( $V_{DD}$ - $V_{EE}$ ) . . . . .  
 . . . . .  $V_{DD} - 13.5V$  to  $V_{DD} + 0.3V$   
 Input Voltage . . . . . -0.3V to  $V_{DD} + 0.3V$   
 Operating Temperature . . . . . -20°C to + 75°C  
 Storage Temperature . . . . . -55°C to + 125°C

**\*Comments**

Stresses above those listed under "Absolute Maximum Ratings" may cause permanent damage to this device. These are stress ratings only. Functional operation of this device at these or any other conditions above those indicated in the operational sections of this specification is not implied or intended. Exposed to the absolute maximum rating conditions for extended periods may affect device reliability.

**DC Electrical Characteristics** ( $V_{DD} = 5.0V$ ,  $GND = 0V$ ,  $V_{EE} = 0V$ ,  $T_A = 25^\circ C$ )

Symbol	Parameter	Terminal	Min.	Typ.	Max.	Unit	Conditions
$V_{IH}$	Input Voltage	CL1, CL2	$0.7 \times V_{DD}$	-	$V_{DD}$	V	
$V_{IL}$		DL1, DL2	0	-	$0.3 \times V_{DD}$	V	
$V_{OH}$	Output Voltage	DR1, DR2	$V_{DD} - 0.4$	-	-	V	$I_{OH} = -0.4mA$
$V_{OL}$			-	-	0.4	V	$I_{OL} = 0.4mA$
$V_{D1}$	Vi-Sj Voltage	Note 1	-	-	1.1	V	$I_{ON} = 0.1mA$ for one of Sj
$V_{D2}$	Descending		105	V	$I_{ON} = 0.05mA$ for each of Sj		
$I_{IL}$	Input Leakage Current	CL1, CL2 DL1, DL2	-5	-	5	$\mu A$	$V_{IN} = 0$ or $V_{DD}$
$I_{VL}$	Vi Leakage Current	$V_2, V_3, V_{EE}$	-10	-	10	$\mu A$	S1 to S40 open
$I_{DD}$	Power Supply Current	Note 2	-	-	200	$\mu A$	$f_{CL1} = 1KH$ $f_{CL2} = 400KHz$

Note 1:  $V_i - S_j$  ( $V_i = V_{DD}, V_2, V_3, V_{EE}; j = 1$  to 40) equivalent circuit.

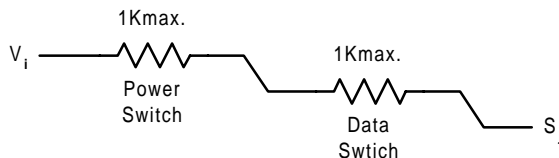

Note 2: Input/output current is excluded. When the input is at the intermediate level with CMOS, some excessive current will flow through the input circuit to the power supply. To avoid this, the input level must be fixed at a high or low state.

**AC Characteristics** ( $V_{DD} = 5.0V$ ,  $GND = 0V$ ,  $V_{EE} = 0V$ ,  $T_A = 25^\circ C$ )

Symbol	Parameter	Terminal	Min.	Typ.	Max.	Unit
$f_{CL2}$	Data Shift Frequency	CL2	-	-	400	KHz
$t_{CWH}$	Clock Width	High	800	-	-	ns
$t_{CWL}$		Low	800	-	-	ns
$t_{DH}$	Data Hold Time	DL1, DL2	300	-	-	ns
$t_{SUD}$	Data Set-up Time	DL1, DL2	300	-	-	ns
$t_{SUC1}$	Clock Set-up Time (CL2 $\rightarrow$ CL1)	CL1, CL2	500	-	-	ns
$t_{SUC2}$	Clock Set-up Time (CL1 $\rightarrow$ CL2)	CL1, CL2	500	-	-	ns
$t_{CL}$	Clock Rise/Fall Time	CL1, CL2	-	-	200	ns
$t_{PD}$	Data Delay Time	-	75	-	500	ns

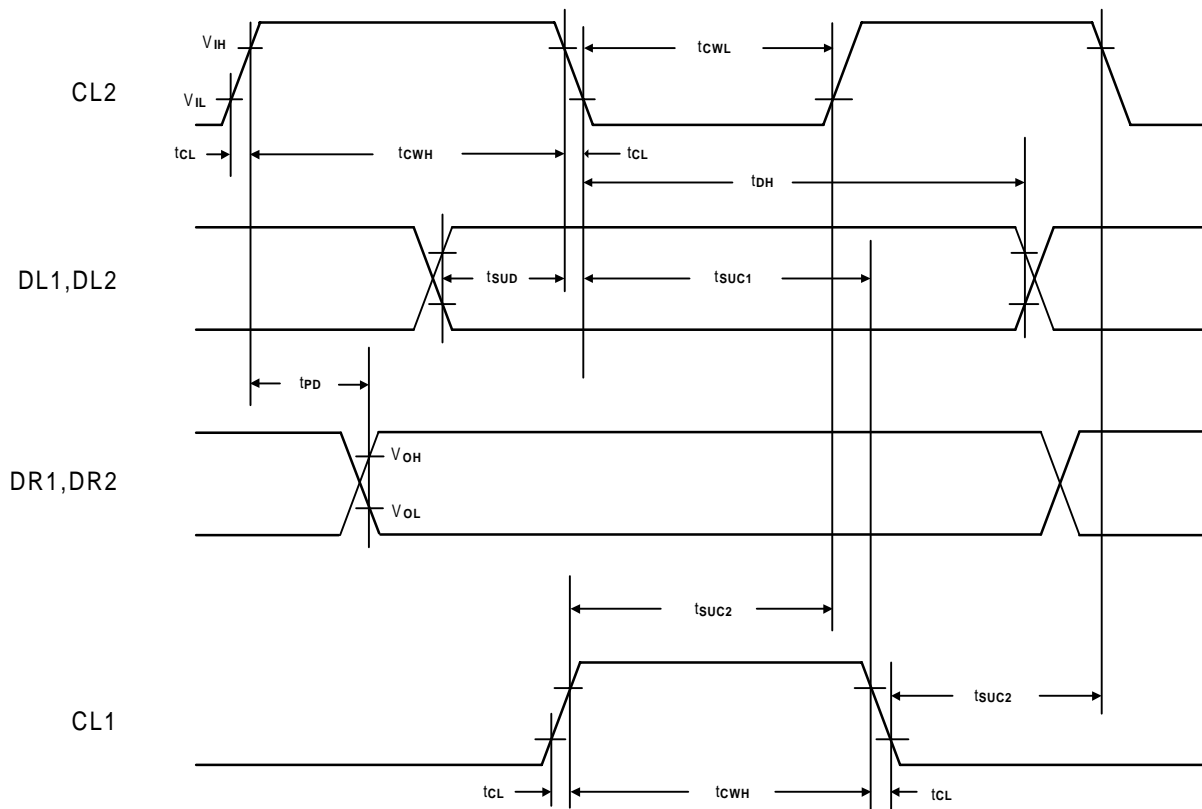
**Timing Waveforms**

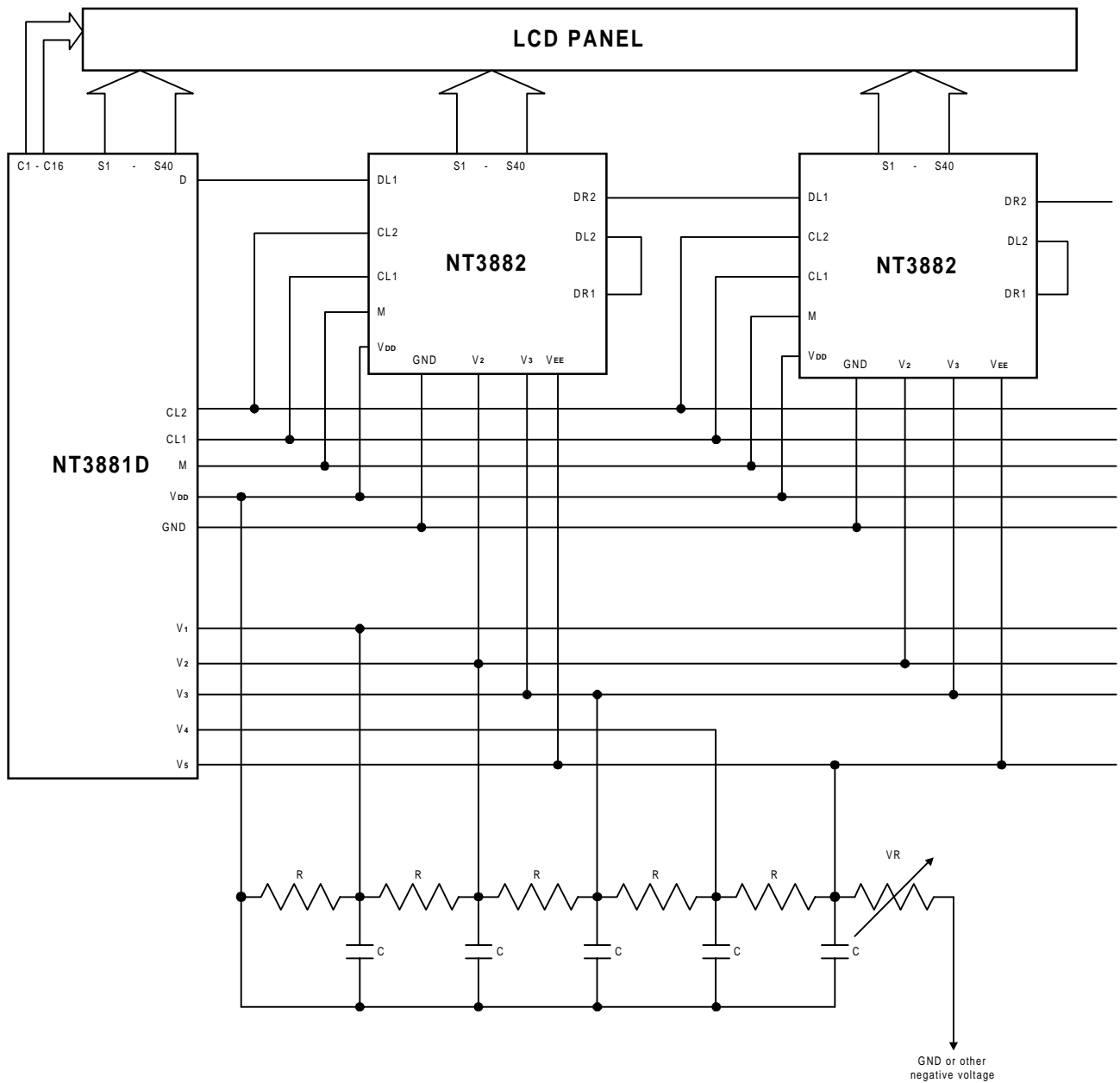
**Application Circuit (for reference only)**

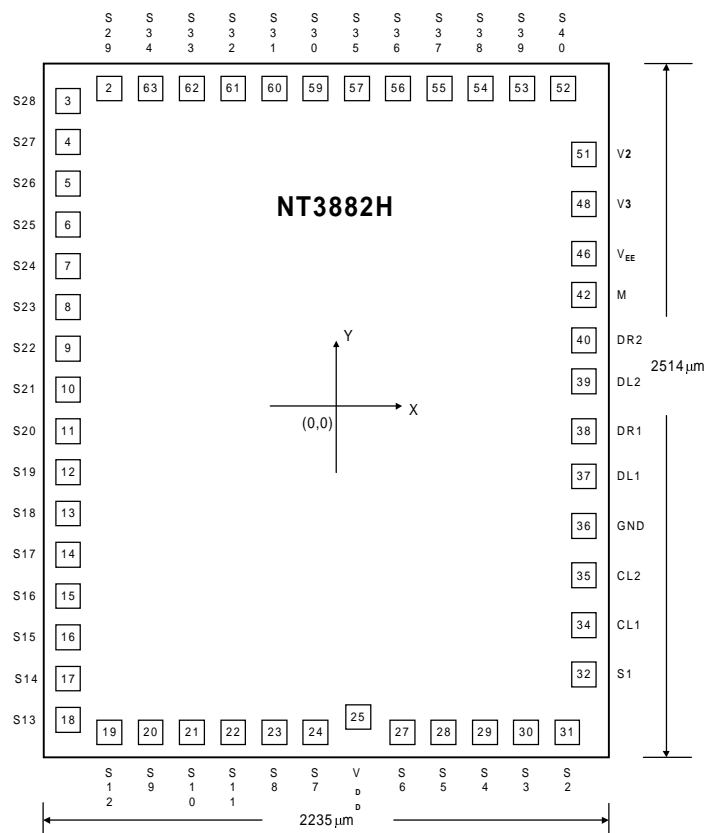
**Bonding Diagram**

\* Connecting IC substrate to  $V_{DD}$  or keeping floating is recommended.

\* Pad window area  $120\mu\text{m} \times 100\mu\text{m}$ .

**Bonding Dimensions**

 unit:  $\mu\text{m}$ 

Pad No.	Designation	X	Y	Pad No.	Designation	X	Y
2	S29	-729	1148	29	S4	621	-1148
3	S28	-985	1125	30	S3	771	-1148
4	S27	-985	975	31	S2	921	-1148
5	S26	-985	825	32	S1	985	-859
6	S25	-985	675	34	CL1	985	-705
7	S24	-985	525	35	CL2	985	-555
8	S23	-985	375	36	GND	985	-373
9	S22	-985	225	37	DL1	985	-204
10	S21	-985	75	38	DR1	985	-54
11	S20	-985	-75	39	DL2	985	96
12	S19	-985	-225	40	DR2	985	246
13	S18	-985	-375	42	M	985	396
14	S17	-985	-525	46	V <sub>EE</sub>	985	562
15	S16	-985	-675	48	V <sub>3</sub>	985	722
16	S15	-985	-825	51	V <sub>2</sub>	985	882
17	S14	-985	-975	52	S40	921	1148
18	S13	-985	-1125	53	S39	771	1148
19	S12	-729	-1148	54	S38	621	1148
20	S9	-579	-1148	55	S37	471	1148
21	S10	-429	-1148	56	S36	321	1148
22	S11	-279	-1148	57	S35	171	1148
23	S8	-129	-1148	59	S30	21	1148
24	S7	21	-1148	60	S31	-129	1148
25	V <sub>DD</sub>	171	-1090	61	S32	-279	1148
27	S6	321	-1148	62	S33	-429	1148
28	S5	471	-1148	63	S34	-579	1148

**Ordering Information**

Part No.	Package
NT3882H	CHIP FORM
NT3882F	64L QFP



**Package Information**
**QFP 64L Outline Dimensions**

unit: inches/mm

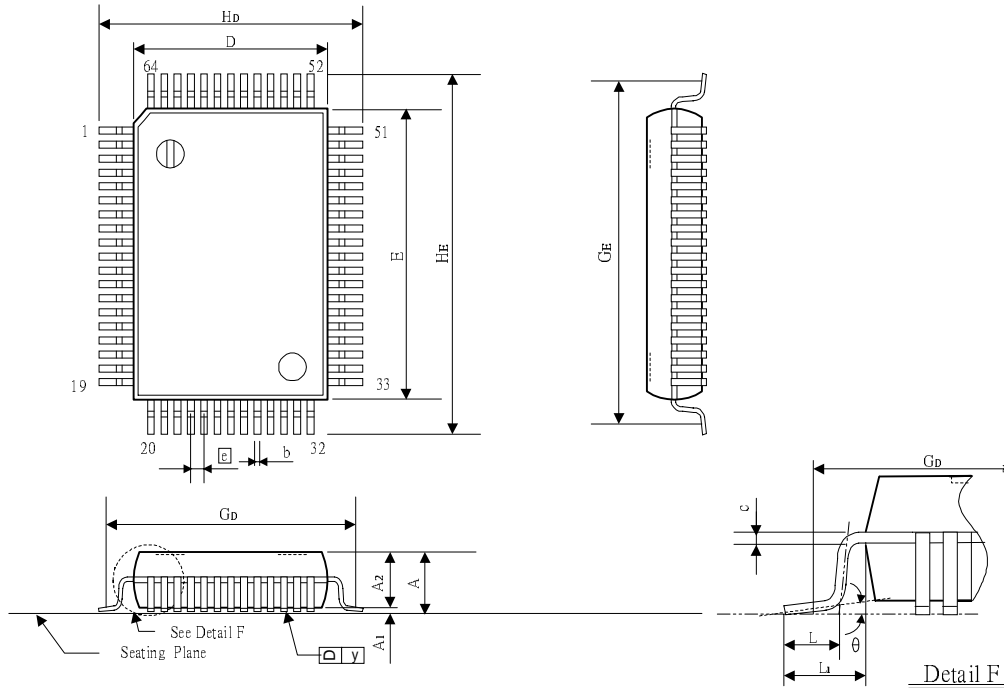

Symbol	Dimensions in inches	Dimensions in mm
A	0.130 Max.	3.30 Max.
A <sub>1</sub>	0.004 Min.	0.10 Min.
A <sub>2</sub>	0.112 ± 0.005	2.85 ± 0.13
b	0.016 +0.004 -0.002	0.40 +0.10 -0.05
c	0.006 +0.004 -0.002	0.15 +0.10 -0.05
D	0.551 ± 0.005	14.00 ± 0.13
E	0.787 ± 0.005	20.00 ± 0.13
e	0.039 ± 0.006	1.00 ± 0.15
G <sub>D</sub>	0.693 NOM.	17.60 NOM.
G <sub>E</sub>	0.929 NOM.	23.60 NOM.
H <sub>D</sub>	0.740 ± 0.012	18.80 ± 0.31
H <sub>E</sub>	0.976 ± 0.012	24.79 ± 0.31
L	0.047 ± 0.008	1.19 ± 0.20
L <sub>1</sub>	0.095 ± 0.008	2.41 ± 0.20
y	0.006 Max.	0.15 Max.
θ	0° ~ 12°	0° ~ 12°

**Notes:**

- Dimensions D & E do not include resin fins.
- Dimensions G<sub>D</sub> & G<sub>E</sub> are for PC Board surface mount pad pitch design reference only.