

SANYO

No. 1965A

LC7981**CONTROLLER FOR THE LC DOT MATRIX
GRAPHIC DISPLAY****Summary**

The LC7981 is a controller LSI for the liquid crystal dot matrix graphic display. It stores display data sent from the 8-bit microcomputer in the display RAM attached externally and generates dot matrix LC drive signals.

The LC7981 has two modes — the graphic mode, in which each bit of data from the external RAM either lights or does not light a dot in the LCD, and the character mode, in which character codes stored in the external RAM generate dot patterns through the built-in character-generator ROM. These two ways enable the LC7981 to cover a wide variety of applications.

As the LC7981 is fabricated using CMOS process technology, combining it with a CMOS microcomputer produces an LCD device of low power demand.

Features

1. Liquid crystal dot matrix graphic display controller
2. Display control capacity.
Graphic mode ----- 512K dots (2^{16} bytes)
Character mode ----- 4096 characters (2^{12} characters)
3. Character generator ROM ----- 7360 bits
Character font 5 x 7 dots 160 types
Character font 5 x 11 dots 32 types } Total 192 types
(Extendable to 4K bytes with an external ROM)
4. Interfacing allowed with 8-bit MPU
5. Display duty (selectable by program)
From static to 1/256 duty
6. A variety of instruction functions
Scroll, cursor on/off/blink, character blink, bit manipulation
7. Display system ----- A system or B system selectable
8. Built-in oscillator (resistor, capacitor attached externally)
9. Low power demand
10. Single +5V power supply

Package Dimensions 3055A-Q60C1C
(unit: mm)

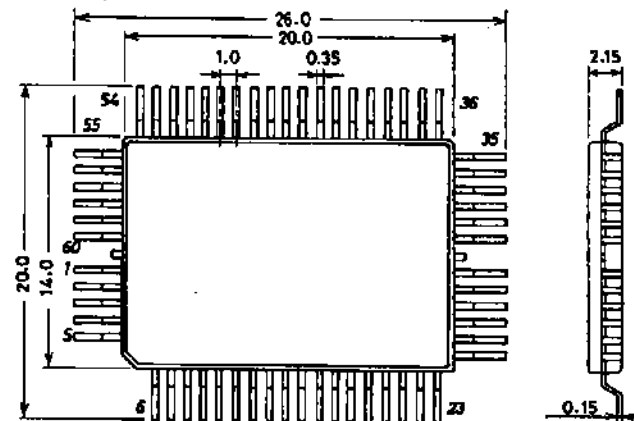

SANYO: QIP60C

SANYO Electric Co., Ltd. Semiconductor Business Headquarters
TOKYO OFFICE Tokyo Bldg., 1-10, 1 Chome, Ueno, Taito-ku, TOKYO, 110 JAPAN

LC7981

Absolute Maximum Ratings/ $T_a=25^\circ\text{C}$, $\text{GND}=0\text{V}$

			unit
Maximum Supply Voltage	V_{DD} max	-0.3to+7.0	V
Input Voltage	V_I	-0.3to $V_{DD}+0.3$	V
Output Voltage	V_O	-0.3to $V_{DD}+0.3$	V
Allowable Power Dissipation	P_d max	$T_a=75^\circ\text{C}$ 200	mW
Operating Temperature	T_{opr}	-20to+75	$^\circ\text{C}$
Storage Temperature	T_{stg}	-55to+125	$^\circ\text{C}$

Allowable Operating Conditions/ $T_a=-20$ to $+75^\circ\text{C}$, $\text{GND}=0\text{V}$

			min	typ	max	unit
Supply Voltage	V_{DD}		4.75		5.25	V
Input "H"-Level Voltage	V_{IH1}	All input, I/O terminals except for $\overline{\text{SYNC}}$, CR	2.2		V_{DD}	V
Input "L"-Level Voltage	V_{IL1}		0		0.8	V
Input "H"-Level Voltage	V_{IH2}	$\overline{\text{SYNC}}$, CR	$0.7V_{DD}$		V_{DD}	V
Input "L"-Level Voltage	V_{IL2}	$\overline{\text{SYNC}}$, CR	0		$0.3V_{DD}$	V
Output "H"-Level Voltage	V_{OH1}	$I_{OH}=-0.6\text{mA}$ DB0to7, $\overline{\text{WE}}$, MA0to15, MD0to7	2.4		V_{DD}	V
Output "L"-Level Voltage	V_{OL1}	$I_{OL}=1.6\text{mA}$ DB0to7, $\overline{\text{WE}}$, MA0to15, MD0to7	0		0.4	V
Output "H"-Level Voltage	V_{OH2}	$I_{OH}=-0.6\text{mA}$ $\overline{\text{SYNC}}$, CPO, FLM, CL1, CL2, D1, D2, MA, MB	$V_{DD}-0.4$		V_{DD}	V
Output "L"-Level Voltage	V_{OL2}	$I_{OL}=0.6\text{mA}$ $\overline{\text{SYNC}}$, CPO, FLM, CL1, CL2, D1, D2, MA, MB	0		0.4	V
Internal Clock Operation						
Clock OSC Frequency	f_{OSC}	$C_f=15\text{pF} \pm 5\%$, $R_f=39\text{k}\Omega \pm 2\%$, Note 1	500	600	700	kHz
External Clock Operation						
Clock Frequency	f_{CP}	Note 2			2.5	MHz
Clock Duty	Duty	Note 3	47.5	50	52.5	%
Clock Rise Time	t_{rcp}	Note 3			50	ns
Clock Fall Time	t_{fcp}	Note 3			50	ns

Electrical Characteristics/ $T_a=-20$ to $+75^\circ\text{C}$, $\text{GND}=0\text{V}$, $V_{DD}=5\text{V} \pm 5\%$

			min	typ	max	unit
Input Leak Current	I_{IN}	$V_{IN}=0$ to V_{DD} , $\overline{\text{CS}}$, E, RS, R/W, $\overline{\text{RES}}$	-5		5	μA
Current Dissipation	I_{CC1}	CR oscillation, $f_{OSC}=600\text{kHz}$		2	4	mA
Current Dissipation	I_{CC2}	External clock, $f_{CP}=2.5\text{MHz}$		3	5	mA
Pull-up Current	I_{PL}	$V_{IN}=\text{GND}$, DB0to7, RD0to7, MD0to7		10	20	μA

(Note 1)

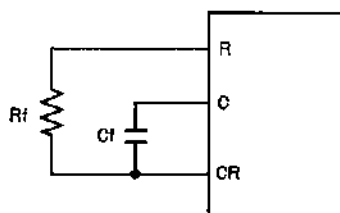

$C_f=15\text{pF} \pm 5\%$
 $R_f=39\text{k}\Omega \pm 2\%$
 (at $f_{OSC}=600\text{kHz}$ typ.)

(Note 2)

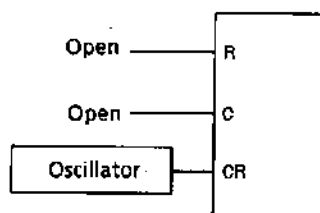

(Note 3)

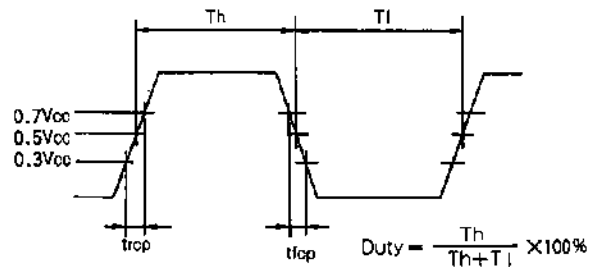

Timing Characteristics

● Bus read/write operation 1

READ CYCLE

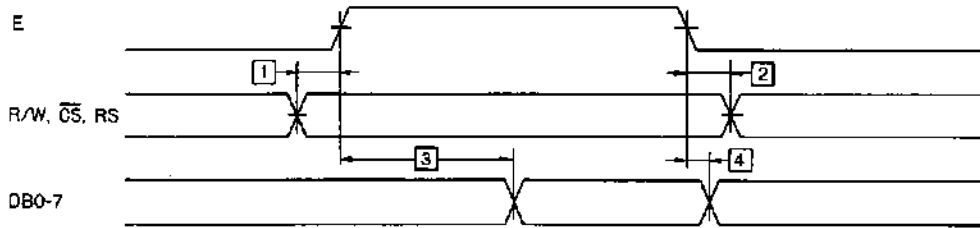

WRITE CYCLE



Ta = -20to+75°C, VDD = 5 V ± 5%, GND = 0 V

No	Item	Symbol	min	typ	max	unit	Conditions
1	Address set-up time	tAS	90			ns	
2	Address hold time	tAH	10			ns	
3	Data delay time (read)	tDDR			140	ns	CL=50pF
4	Data hold time (read)	tDHR	10			ns	
5	Data set-up time (write)	tDSW	220			ns	
6	Data hold time (write)	tDHW	20			ns	

Note: Definition of the test waveform



The input terminals are driven at 2.4V and 0.45V. Timing is measured at 1.5V.

● Bus read/write operation 2

DATA READ CYCLE

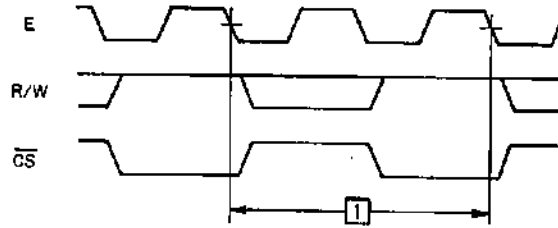

DATA WRITE CYCLE

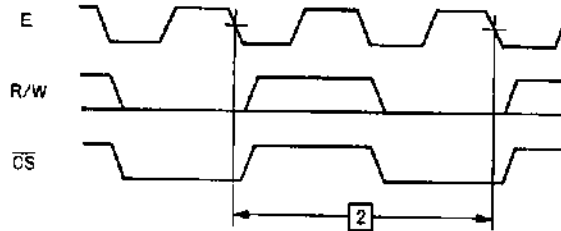

Ta = -20 to +75°C, VDD = 5 V ± 5%, GND = 0 V

No	Item	Symbol	min	typ	max	unit	Instruction register value
1	Read cycle time	TRCY			$\frac{(H_P + 2) \times 10^3}{F_{OSC}} + 200$	ns	0 DH
2	Write cycle time	TWCY1			$\frac{(2 H_P + 2) \times 10^3}{F_{OSC}} + 200$	ns	0 EH, 0 FH
2	Write cycle time	TWCY2			$\frac{(H_P + 2) \times 10^3}{F_{OSC}} + 200$	ns	0 CH
2	Write cycle time	TWCY3			$\frac{2000}{F_{OSC}} + 200$	ns	00H, 01H, 02H, 03H 04H, 08H, 09H 0 AH, 0 BH

Notes: (1) In the character mode, Hp is the number of horizontal dots per character in a character display. In the graphic mode, Hp indicates how many bits from RAM appear in a 1-byte display.

(2) FOSC is the oscillating frequency, expressed in MHz.

(3) All measurement points are at 1.5V.

● Parallel operation (at master mode)

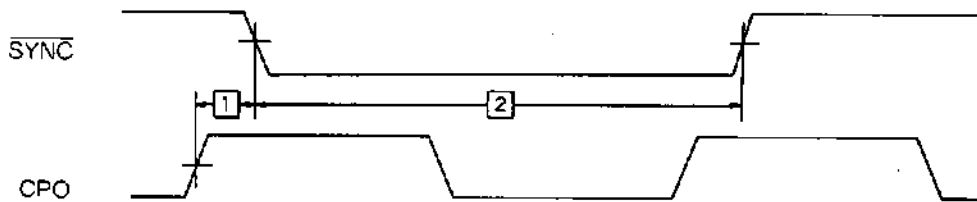

Ta = -20 to +75°C, VDD = 5 V ± 5%, GND = 0 V

No	Item	Symbol	min	typ	max	unit	Conditions
1	SYNC delay time	tDSY			100	ns	
2	SYNC pulse width	tWSY	350			ns	

Notes: (1) All output terminals are under no load.

(2) All measurement points are at 0.5VDD.

LC7981

● Interface with external RAM and ROM

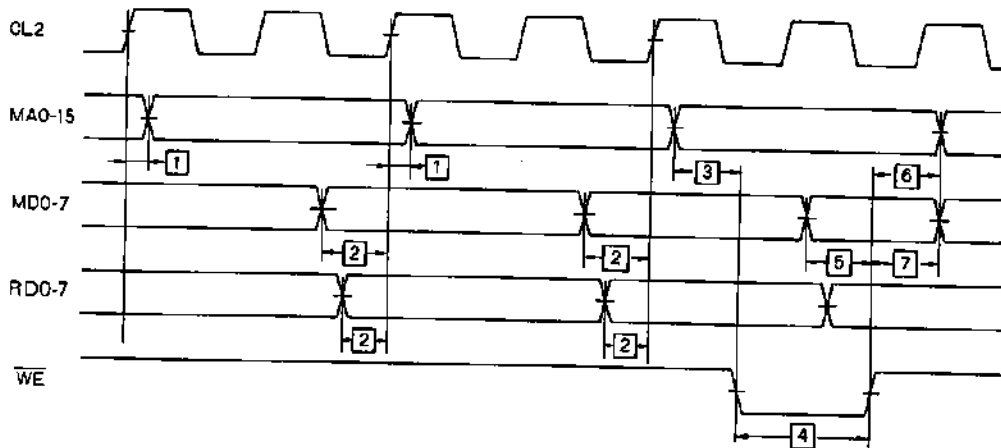

READ CYCLE $T_a = -20\text{ to }+75^\circ\text{C}$, $V_{DD} = 5\text{ V} \pm 5\%$, $GND = 0\text{ V}$

No	Item	Symbol	min	typ	max	unit	Conditions
1	MA0-15 read address delay time	t_{DMAR}			95	ns	
2	MD0-7 · RD0-7 set-up time	t_{SMR}	105			ns	

WRITE CYCLE $T_a = -20\text{ to }+75^\circ\text{C}$, $V_{DD} = 5\text{ V} \pm 5\%$, $GND = 0\text{ V}$

No	Item	Symbol	min	typ	max	unit	Conditions
3	Memory address set-up time	t_{SMAW}	50			ns	
4	\overline{WE} pulse width	t_{WWE}	350			ns	
5	Memory data set-up time	t_{SMDW}	250			ns	
6	Memory address hold time	t_{HMAW}	50			ns	
7	Memory data hold time	t_{HMDW}	50			ns	

Notes: (1) All output terminals are under no load.
 (2) All measurement points are at 1.5V.

● Interface with the driver LSI

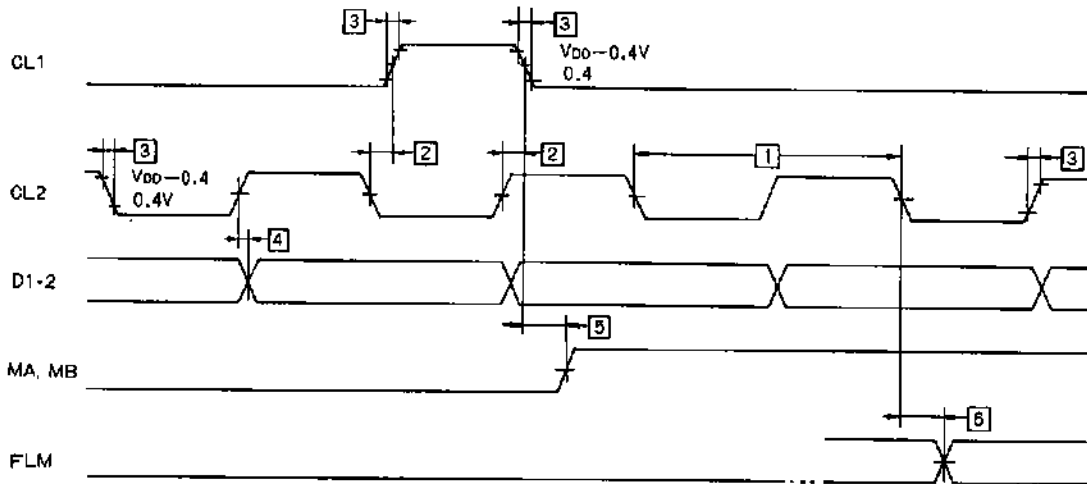

Ta = -20 to +75°C, VDD = 5 V ± 5%, GND = 0 V

No	Item	Symbol	min	typ	max	unit	Conditions
1	Clock cycle time	TCYC	400			ns	
2	Clock phase difference	TDCL			100	ns	
3	Clock rise/fall time	TCRF			30	ns	
4	D1-2 phase difference	TDD			100	ns	
5	MA, MB phase difference	TDMA			200	ns	
6	FLM phase difference	TDFM			200	ns	

Notes: (1) All output terminals are under no load.
 (2) All measurement points other than those specified are at 0.5VDD.

LC7981

Pin Assignment

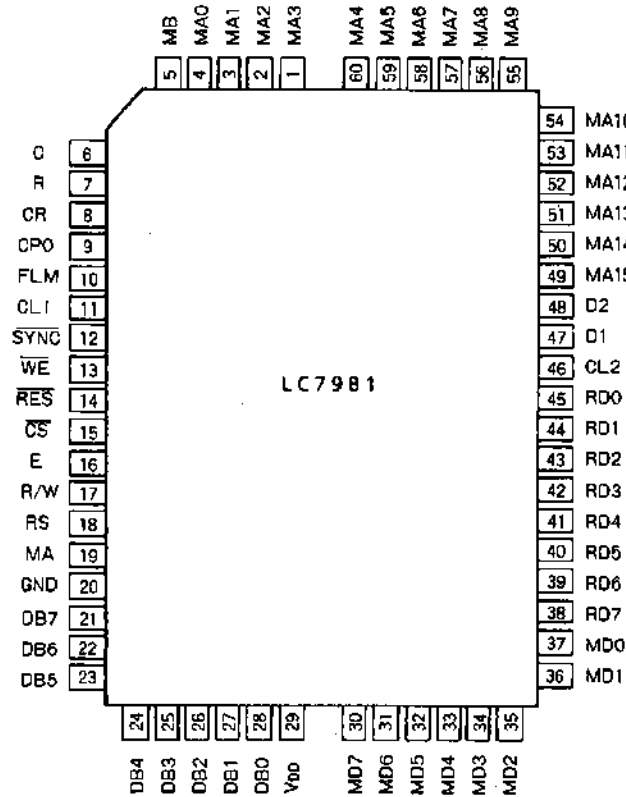

(Top view)

Block Diagram

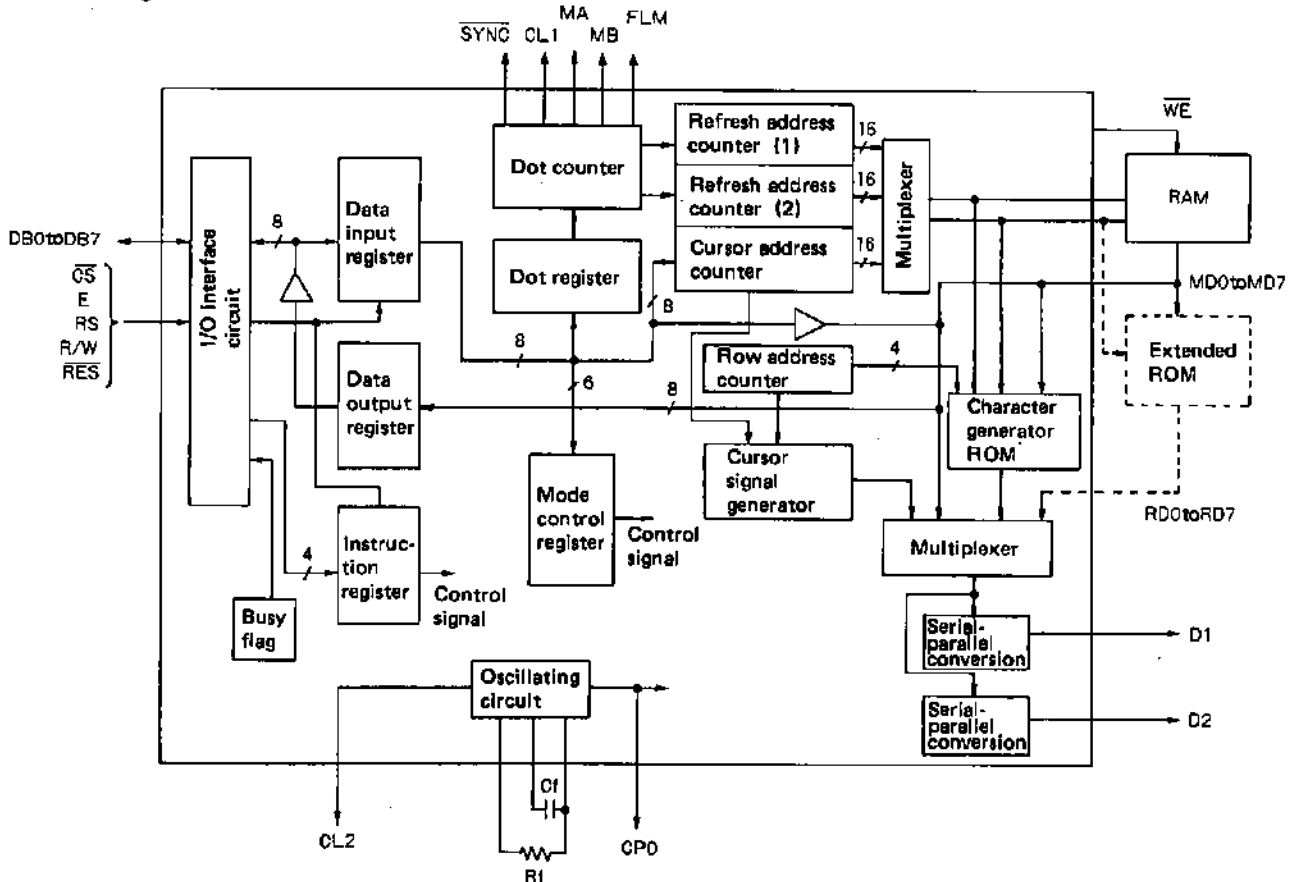

* When the ROM is extended, MA0 to MA11 are used for RAM addresses and MA12 to MA15 are used for the extended ROM.

Function of each block● **Register**

The LC7981 has 5 types of registers — the instruction register, data input register, data output register, dot register, and mode control register.

The instruction register stores such instruction codes as the start address, cursor address specification, etc. It consists of 4 bits, and the lower 4 bits of the data bus, DB0 to DB3, are written into it.

The data input register temporarily stores data to be written into the external RAM, dot register, and mode control register. It consists of 8 bits.

The data output register temporarily stores data to be read from external RAM, and consists of 8 bits. When the cursor address is written into the cursor address counter via the data input register and the memory read instruction is set in the instruction register, data in external RAM is read into the data output register by internal operation. With the next instruction, the MPU reads the data output register, and completes data transfer to the MPU.

The dot register stores dot information such as the character pitch, the number of vertical dots, etc. Data sent from the MPU is written into the dot register via the data input register.

The mode control register stores LCD status information such as display on/off and cursor on/off/blink. It consists of 6 bits. Data sent from the MPU is written into this register via the data input register.

● **Busy flag**

When the busy flag is "1", the LC7981 is operating internally. At this time, the next instruction cannot be accepted. The busy flag is output to DB7 when RS=1, RW=1. The next instruction must be written after ensuring that the busy flag is "0". When the maximum value of the read cycle time or write cycle time has been passed after the execution of the preceding data read instruction or data write instruction, the next instruction can be executed without checking the busy flag.

● **Dot counter**

The dot counter generates LC display timing according to the contents of the dot register.

● **Refresh address counter**

The refresh address counter controls addresses of the external RAM, character generator ROM, extended ROM and is available in two types — refresh address counter (1) and refresh address counter (2). The former is for the upper screen, and the latter for the lower screen. In the graphic mode, 16-bit data is output and used as the address signal for the external RAM. In the character mode, the high-order 4 bits are ignored and 4 bits of the row address counter are output instead. The 4 bits are used as the address of the extended ROM.

● **Character generator ROM**

The character generator ROM has a total of 7360 bits and stores data on 192 kinds of characters. Character codes from the external RAM and row codes from the row address counter are added to address signals, and ROM outputs 5-bit dot data.

There are 192 kinds of character fonts, of which 160 are 5 x 7 and 32 are 5 x 11. With extended ROM, character fonts can be increased to 256 kinds sized 8 x 16.

● **Cursor address counter**

The cursor address counter is a 16-bit counter which can be preset by instruction. When data is read from or written into external RAM (i.e., read/write of display dot data or character codes), the counter retains the addresses. The value indicated on the cursor address counter is automatically incremented by 1 when instructions to read/write display data and to perform bit set/clear are issued.

● **Cursor signal generator**

In the character mode, the cursor can be displayed by means of instructions. The cursor is generated automatically when the cursor address counter and the row address counter reach the specified value.

● **Parallel-serial conversion**

The two parallel-serial conversion circuits simultaneously transfer parallel data from the external RAM, character generator, and extended ROM to the upper and lower LC screen drive circuits as serial data.

LC7981

Pin Function

Description	Pin No.	Function
DB0 to 7	21 to 28	Data bus ----- Three-state I/O common terminal, terminal for transmitting/receiving data to/from the MPU.
\overline{CS}	15	Chip select ----- Selection allowed when $\overline{CS}=0$
R/W	17	Read/write ----- R/W=1 ----- MPU ← LC7981 R/W=0 ----- MPU → LC7981
RS	18	Register select ----- RS=1 ----- instruction register RS=0 ----- data register
E	16	Enable ----- Data is written on the negative transition of E. Data can be read while E=1.
CR, R, C	6, 7, 8	Terminals for the CR oscillator
\overline{RES}	14	Reset ----- Setting RES to 0 selects display OFF, slave mode, and Hp=6.
MA0 to 15	1 to 4 49 to 60	Address output for the display RAM. For character display, raster address for external CG is output at MA12 to 15.
MD0 to 7	30 to 37	Display data bus ----- Three-state I/O common terminals.
RD0 to 7	38 to 45	ROM data input ----- Dot data from the external character generator is input.
\overline{WE}	13	Write enable ----- Display RAM write signal.
CL2	46	Display data shift clock signal.
CL1	11	Display data latch signal.
FLM	10	Frame signal.
MA	19	LC drive signal ----- AC signal ----- A system
MB	5	LC drive signal ----- AC signal ----- B system
D1, D2	47, 48	Display data serial output ----- D1 ----- for the upper screen D2 ----- for the lower screen
CPO	9	Clock for slave
\overline{SYNC}	12	Sync signal for parallel operation ----- Three-state input/output common terminal Master mode ----- Sync signal is output. Slave mode ----- Sync signal is input.

● Display control instruction

Display is controlled by writing data into the instruction register and 13 data registers. The instruction register and the data register are distinguished by the RS signal. First, write 4-bit data in the instruction register when RS=1, then specify the code of the data register. Next, with RS=0, write 8-bit data in the data register, which executes the specified instruction.

A new instruction cannot be accepted while an old instruction is being executed. As the Busy flag is set under this condition, write an instruction only after reading the Busy flag and making sure that it is 0.

However, the next instruction can be executed without checking the busy flag when the maximum read cycle time or the write cycle time has been exceeded after execution of the previous data read instruction or the data write instruction. The busy flag does not change when data is written into the instruction register (RS=1). Therefore, the busy flag need not be checked immediately after writing data into the instruction register.

1) Mode control

Write code "00H" (in hexadecimal notation) in the instruction register and specify the mode control register.

Register	R/W	RS	DB7	DB6	DB5	DB4	DB3	DB2	DB1	DB0
Instruction register	0	1	0	0	0	0	0	0	0	0
Mode control register	0	0	0	0	MODE Data					

DB5	DB4	DB3	DB2	DB1	DB0	Cursor/blink	CG	Graphic/character display
1 / 0	1 / 0	0	0	0	0	Cursor OFF	Built-in CG	Character display
		0	1			Cursor ON		
		1	0			Cursor OFF character blink		
		1	1			Cursor blink		
		0	0		1	Cursor OFF	External CG	
		0	1			Cursor ON		
		1	0			Cursor OFF character blink		
		1	1			Cursor blink		
		0	0	1	0	Cursor/blink	CG	Graphic mode
Display ON/OFF	Master/slave	Blink	Cursor	Mode	External/built-in CG			

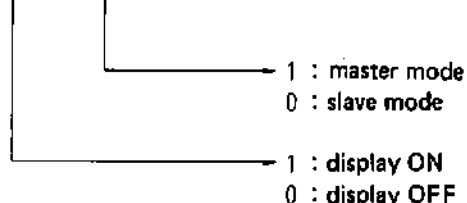

2) Setting the character pitch

Register	R/W	RS	DB7	DB6	DB5	DB4	DB3	DB2	DB1	DB0
Instruction register	0	1	0	0	0	0	0	0	0	1
Character pitch register	0	0	(Vp-1) Binary				0	(Hp-1) Binary		

Vp is the number of vertical dots per character. Determine Vp with the pitch between two vertically placed characters taken into consideration. This value is meaningful only in the character display mode. It is invalid in the graphic mode.

In character mode, Hp indicates the number of horizontal dots per character, from the leftmost part of one character to the leftmost part of the next. In the graphic mode, Hp indicates how many bits (or dots) from RAM appear in a 1-byte display.

Hp must take one of the following three values.

HP	DB2	DB1	DB0	
6	1	0	1	Horizontal character pitch 6
7	1	1	0	7
8	1	1	1	8

3) Setting the number of characters

Register	R/W	RS	DB7	DB6	DB5	DB4	DB3	DB2	DB1	DB0
Instruction register	0	1	0	0	0	0	0	0	1	0
Character number register	0	0	(Hn-1) Binary							

In the character display mode, Hn indicates the number of characters in the horizontal direction. In the graphic mode, it indicates the number of bytes in the horizontal direction. The total number of dots positioned horizontally on the screen n is given by the formula

$$n = H_p \times H_n$$

Even numbers in the range 2 to 256 (decimal) can be set as Hn.

4) Setting the time division number (display duty)

Register	R/W	RS	DB7	DB6	DB5	DB4	DB3	DB2	DB1	DB0
Instruction register	0	1	0	0	0	0	0	0	1	1
Time division register	0	0	(Nx-1) Binary							

Consequently, 1/Nx is the display duty.

Decimal numbers within the range 1 to 256 can be set as Nx.

5) Setting the cursor position

Register	R/W	RS	DB7	DB6	DB5	DB4	DB3	DB2	DB1	DB0
Instruction register	0	1	0	0	0	0	0	1	0	0
Cursor position register	0	0	0	0	0	0	(Cp-1) Binary			

In the character display mode, Cp indicates the line at which the cursor is displayed. For example, when Cp=8 (decimal) is specified, the cursor is displayed beneath the character of the 5 x 7 dot-font. The horizontal length of the cursor equals Hp (the horizontal character pitch). Decimal values in the range 1 to 16 can be assigned to Cp. When the value is less than the vertical character pitch Vp (Cp < Vp), display priority is given to the cursor (provided the cursor display is ON). The cursor is not displayed when Cp < Vp. The horizontal length of the cursor equals Hp.

6) Setting the display start lower address

Register	R/W	RS	DB7	DB6	DB5	DB4	DB3	DB2	DB1	DB0
Instruction register	0	1	0	0	0	0	1	0	0	0
Display start address register (lower byte)	0	0	(start address lower byte) binary							

7) Setting the display start upper address

Register	R/W	RS	DB7	DB6	DB5	DB4	DB3	DB2	DB1	DB0
Instruction register	0	1	0	0	0	0	1	0	0	1
Display start address register (upper byte)	0	0	(start address upper byte) binary							

This instruction writes the display start address value in the display start address register. The display start address is the RAM address at which data to be displayed at the leftmost position of the top line of the screen is stored. The start address consists of 16 bits (upper and lower).

8) Setting the cursor (lower) address (RAM read/write lower address)

Register	R/W	RS	DB7	DB6	DB5	DB4	DB3	DB2	DB1	DB0
Instruction register	0	1	0	0	0	0	1	0	1	0
Cursor address counter (lower byte)	0	0	(cursor address lower byte) binary							

9) Setting the cursor (upper) address (RAM read/write upper address)

Register	R/W	RS	DB7	DB6	DB5	DB4	DB3	DB2	DB1	DB0
Instruction register	0	1	0	0	0	0	1	0	1	1
Cursor address counter (upper byte)	0	0	(cursor address upper byte) binary							

This instruction writes the cursor address value in the cursor address counter. The cursor address indicates the address for exchanging display data and character codes with RAM. In other words, data at the address specified by the cursor address is read from or written into RAM. In character display, the cursor is displayed at the position specified by the cursor address.

The cursor address is divided into a lower address (8 bits) and an upper address (8 bits). It should be set in accordance with the following rules.

1	To rewrite (set) both lower and upper addresses:	First set the lower address, then the upper.
2	To rewrite the lower address:	Always reset the upper address after setting the lower address.
3	To rewrite the upper address only:	Set the upper address. It is necessary to reset the lower address.

The cursor address counter is a 16-bit up-counter with set/reset functions: when the Nth bit goes from 1 to 0, the count of the (N + 1)th bit increments by one. Accordingly, when the lower address is set so that the lower MSB (8th bit) changes from 1 to 0, the LSB (1st bit) of the upper counter must increment by one. When setting the cursor address, set the lower and upper addresses as a 2-byte continuous instruction.

10) Writing display data

Register	R/W	RS	DB7	DB6	DB5	DB4	DB3	DB2	DB1	DB0	
Instruction register	0	1	0	0	0	0	1	1	0	0	
RAM	0	0	MSB (pattern data, character code)							LSB	

Write code "0CH" in the instruction register. Then, write 8-bit data with RS=0, and the data is written into RAM as display data or character codes at the address specified by the cursor address counter. After writing, the count of the cursor address counter increments by 1.

11) Reading display data

Register	R/W	RS	DB7	DB6	DB5	DB4	DB3	DB2	DB1	DB0	
Instruction register	0	1	0	0	0	0	1	1	0	1	
RAM	1	0	MSB (pattern data, character code)							LSB	

Write "0DH" in the instruction register. Then, establish the read status with RS=0, and data in the RAM can be read. The procedure for reading data is as follows:

This instruction outputs the contents of the data output register to DB0 to 7, then transfers the RAM data indicated by the cursor address to the data output register. It then increments the cursor address by 1, which means that correct data cannot be read in the first read operation. The specified value is output in the second read operation. Accordingly, a dummy read operation must be performed once when reading data after setting the cursor address.

12) Bit clear

Register	R/W	RS	DB7	DB6	DB5	DB4	DB3	DB2	DB1	DB0
Instruction register	0	1	0	0	0	0	1	1	1	0
Bit clear	0	0	0	0	0	0	0	(NB-1) Binary		

13) Bit set

Register	R/W	RS	DB7	DB6	DB5	DB4	DB3	DB2	DB1	DB0
Instruction register	0	1	0	0	0	0	1	1	1	1
Bit set	0	0	0	0	0	0	0	(NB-1) Binary		

As the bit-clear or bit-set instruction, 1 bit of a 1 byte of data in display RAM is set to 0 or 1. The bit specified by NB is set to 0 for the bit-clear instruction and 1 for the bit-set instruction. The RAM address is specified by the cursor address, which is automatically incremented by 1 at the completion of the instruction. NB is a value in the range from 1 to 8. The LSB is indicated by NB=1, and the MSB by NB=8.

14) Reading the BUSY flag

Register	R/W	RS	DB7	DB6	DB5	DB4	DB3	DB2	DB1	DB0
Busy flag	1	1	1 / 0	*						

The busy flag is output to DB7 when read mode is established with RS=1. The busy flag is set to 1 while any of the instructions 1) through 13) is being executed. It is set to 0 at the completion of the execution, allowing the next instruction to be accepted. No other instruction can be accepted when the busy flag is 1. Accordingly, before writing an instruction and data, it is necessary to ensure that the busy flag is 0. However, the next instruction can be executed without checking the busy flag when the maximum read cycle time or the write cycle time has been exceeded after execution of the previous data read instruction or the data write instruction.

The busy flag does not change when data is written into the instruction register (RS=1). Therefore, the busy flag need not be checked immediately after writing data into the instruction register.

Specification of the instruction register is unnecessary to read the busy flag.

The relation between the LCD panel display and Hp, HN, Vp, Cp, and Nx.

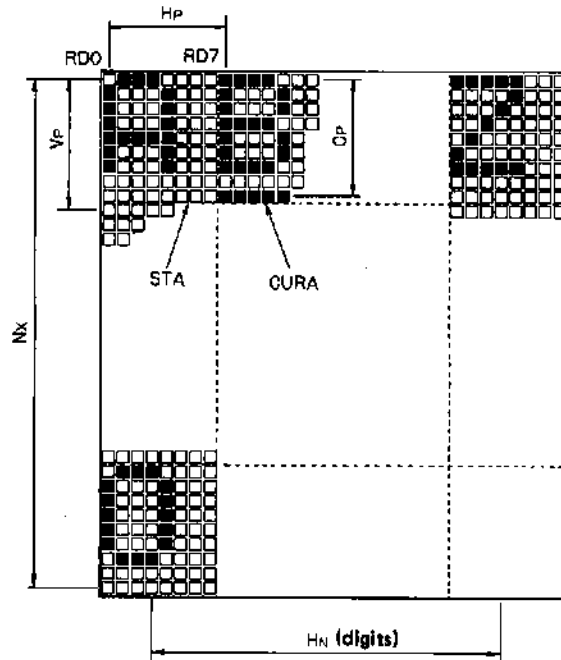

Symbol	Description	Contents	Value
Hp	Horizontal character pitch	Character pitch in the horizontal direction	6 to 8 dots
HN	Number of characters in the horizontal direction	Number of characters (digits) per horizontal line or the number of words per line (graphic)	Even digits in the range 2 to 256
Vp	Vertical character pitch	Character pitch in the vertical direction	1 to 16 dots
Cp	Cursor position	The line number at which the cursor is to be displayed	1 to 16 lines
Nx	Number of lines in the vertical direction	Display duty	1 to 256 lines

Note)

When the number of vertical dots on the screen is m and that of horizontal dots is n,

$$1/m = 1/Nx = \text{display duty}$$

$$n = Hp \times HN$$

$$m/Vp = \text{number of display lines}$$

$$Cp \leq Vp$$

Display mode

Display mode	Display data from the MPU	RAM	LCD panel																								
<p>Character display</p>	<p>Display pattern (8 bits)</p>	<p>RAM bit patterns:</p> <table border="1"> <tr> <td>b7</td><td>b6</td><td>b5</td><td>b4</td><td>b3</td><td>b2</td><td>b1</td><td>b0</td> </tr> <tr> <td>0</td><td>1</td><td>0</td><td>0</td><td>0</td><td>0</td><td>0</td><td>1</td> </tr> <tr> <td>0</td><td>1</td><td>0</td><td>0</td><td>0</td><td>0</td><td>1</td><td>0</td> </tr> </table> <p>Start address</p>	b7	b6	b5	b4	b3	b2	b1	b0	0	1	0	0	0	0	0	1	0	1	0	0	0	0	1	0	<p>HP : 6, 7 or 8 dots</p>
b7	b6	b5	b4	b3	b2	b1	b0																				
0	1	0	0	0	0	0	1																				
0	1	0	0	0	0	1	0																				
<p>Graphic</p>	<p>Character code (8 bits)</p>	<p>RAM bit patterns:</p> <table border="1"> <tr> <td>b7</td><td>b6</td><td>b5</td><td>b4</td><td>b3</td><td>b2</td><td>b1</td><td>b0</td> </tr> <tr> <td>0</td><td>1</td><td>0</td><td>1</td><td>0</td><td>1</td><td>0</td><td>1</td> </tr> <tr> <td>1</td><td>1</td><td>1</td><td>1</td><td>1</td><td>1</td><td>1</td><td>1</td> </tr> </table> <p>Start address</p>	b7	b6	b5	b4	b3	b2	b1	b0	0	1	0	1	0	1	0	1	1	1	1	1	1	1	1	1	<p>HP : 8 dots</p>
b7	b6	b5	b4	b3	b2	b1	b0																				
0	1	0	1	0	1	0	1																				
1	1	1	1	1	1	1	1																				

LC7981

Sample application circuit (1)

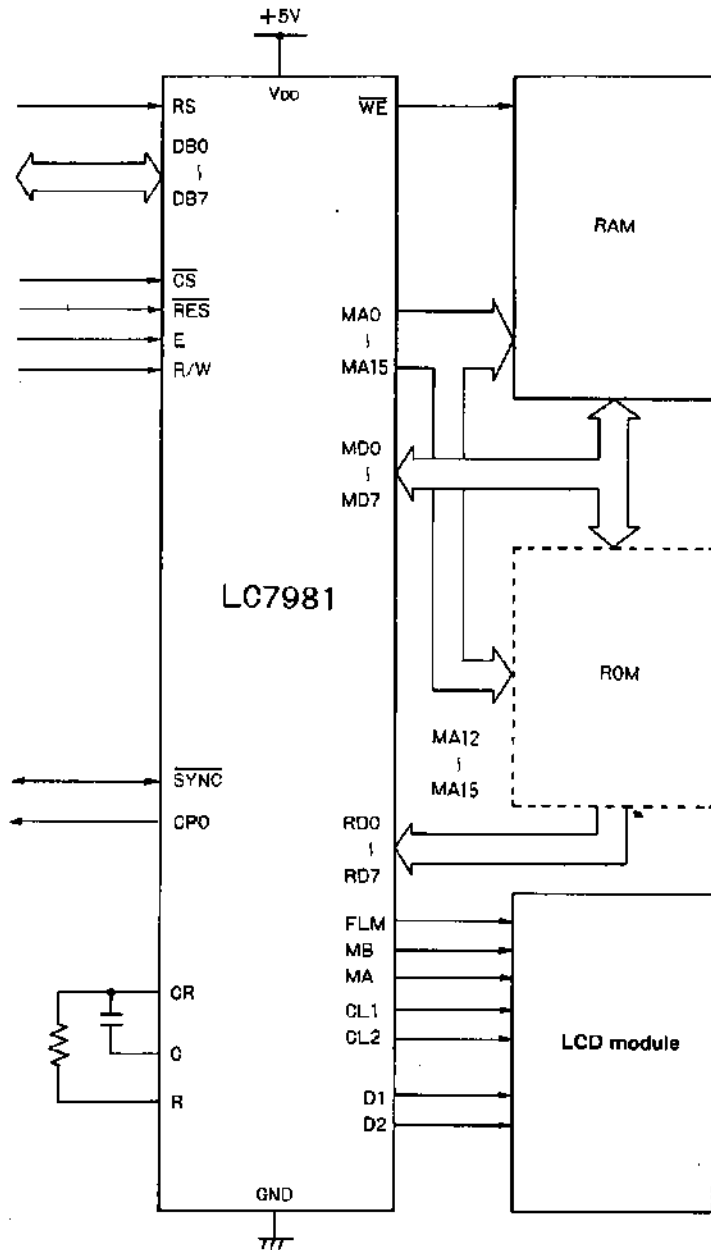

- No products described or contained herein are intended for use in surgical implants, life-support systems, aerospace equipment, nuclear power control systems, vehicles, disaster/crime-prevention equipment and the like, the failure of which may directly or indirectly cause injury, death or property loss.
- Anyone purchasing any products described or contained herein for an above-mentioned use shall:
 - ① Accept full responsibility and indemnify and defend SANYO ELECTRIC CO., LTD., its affiliates, subsidiaries and distributors and all their officers and employees, jointly and severally, against any and all claims and litigation and all damages, cost and expenses associated with such use;
 - ② Not impose any responsibility for any fault or negligence which may be cited in any such claim or litigation on SANYO ELECTRIC CO., LTD., its affiliates, subsidiaries and distributors or any of their officers and employees jointly or severally.
- Information (including circuit diagrams and circuit parameters) herein is for example only; it is not guaranteed for volume production. SANYO believes information herein is accurate and reliable, but no guarantees are made or implied regarding its use or any infringements of intellectual property rights or other rights of third parties.

LC7981

Sample application circuit (2) [Composition of graphic display and character display]

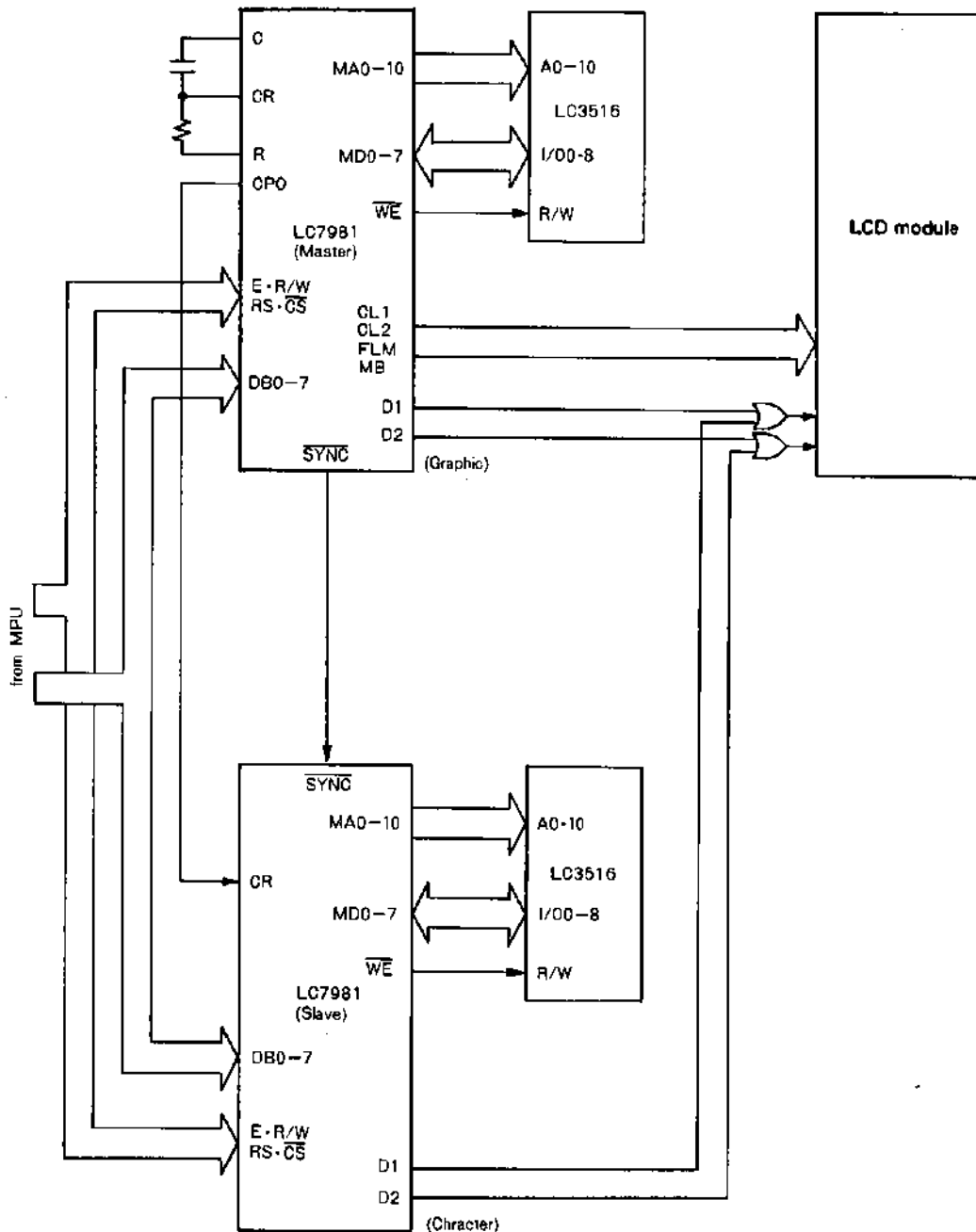

Examples of configuration

- Graphic mode

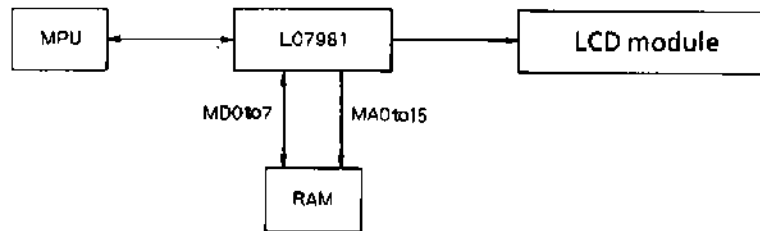

- Character display mode (1) (built-in character generator)

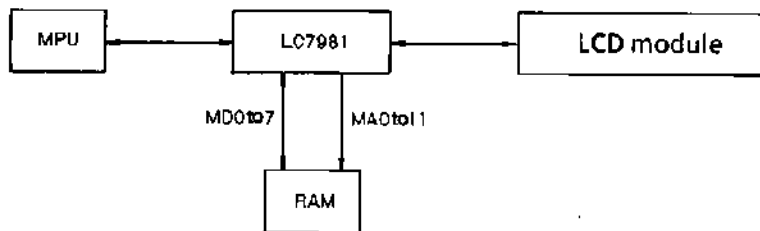

- Character display mode (2) (external character generator)

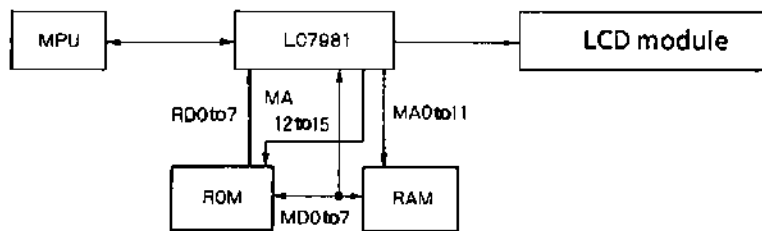

- Parallel operation

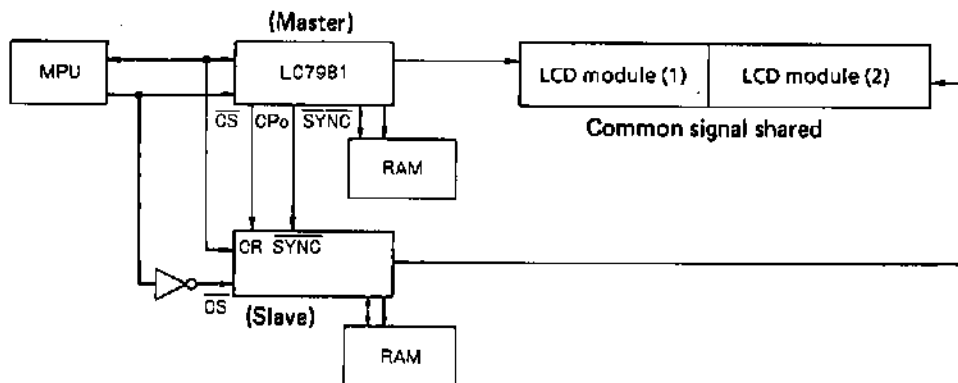

Built-in character generator

Lower 4bit \ Upper 4bit	0010	0011	0100	0101	0110	0111	1010	1011	1100	1101	1110	1111
xxx0000		0	1	2	3	4	5	6	7	8	9	A
xxx0001	!	1	A	0	a	9	.	7	7	4	a	q
xxx0010	"	2	B	R	b	r	"	4	u	x	p	e
xxx0011	#	3	C	S	c	s	_	7	7	7	e	e
xxx0100	\$	4	D	T	t	t	\	1	1	1	h	a
xxx0101	%	5	E	U	e	u	=	7	7	7	e	o
xxx0110	0	6	F	V	f	v	9	h	c	e	p	z
xxx0111	"	7	G	W	w	w	7	7	7	7	g	π
xxx1000	(8	H	X	h	x	4	0	7	7	r	x
xxx1001)	9	I	Y	i	y	9	7	7	7	"	y
xxx1010	*	:	J	Z	j	z	z	3	n	v	j	7
xxx1011	+	;	K	Z	k	z	7	7	7	7	*	7
xxx1100	,	<	L	7	l	l	7	7	7	7	7	7
xxx1101	-	=	M	7	m	7	7	7	7	7	7	7
xxx1110	.	>	N	7	n	7	7	7	7	7	7	7
xxx1111	/	?	O	7	o	7	7	7	7	7	7	7