

## 480/320-Output Channels TFT LCD Gate Driver

### Specification Preliminary

Version: V0.02  
Document No.: ILI5480DS\_V0.02.pdf

**ILI TECHNOLOGY CORP.**

8F, No.38, Taiyuan St., Jhubei City, Hsinchu County 302,  
Taiwan, R.O.C  
Tel.886-3-5600099; Fax.886-3-5600055  
<http://www.ilitek.com>

**Table of Contents**

<b>Section</b>	<b>Page</b>
1. Introduction.....	3
2. Features .....	3
3. Block Diagram .....	4
4. Pin Descriptions .....	5
5. Operation Description .....	6
Device operation principle.....	6
Device operation .....	6
Mode (output channel) selection.....	8
Relationship between RL, STVR and STVL .....	9
Device power supply.....	9
Power ON/OFF Sequence .....	10
6. DC Characteristic .....	12
Absolute Maximum Rating (GND = VSS=0V).....	12
Recommended operating conditions (GND=VSS=0V) .....	12
Electrical Characteristics (GND=VSS=0V) .....	13
7. AC Characteristic .....	14
AC Electrical Characteristics.....	14
Note(1):teef=> VEE Falling Time, From 10% to 90% VEE.....	14
8. Timing Chart.....	15
9. Pin Assignment (IC Face View).....	16
10. Pad Location .....	17
11. Bump Mask Information .....	21
12. Revision History .....	23

## 1. Introduction

ILI5480 is a 480/320-channel outputs gate driver used for driving the gate of TFT LCD panel. After a start pulse is triggered, output pins will output high-driving voltage pulses sequentially for the gate signals of the LCD Panel. This chip also provides shift up/down selection and cascade functions for dot expansion.

## 2. Features

- 2-level output gate driver for TFT LCD panel
- High voltage CMOS process technology COG package
- 480/320 channels output selectable gate driver with 2 dummy output
- Bi-directional data shift capability
- Maximum +40V output driving voltage
- 200KHz maximum operation frequency
- Cascade function for dot-expansion
- 2.7 ~ 3.6V logical interface

ILITEK CONFIDENTIAL

### 3. Block Diagram

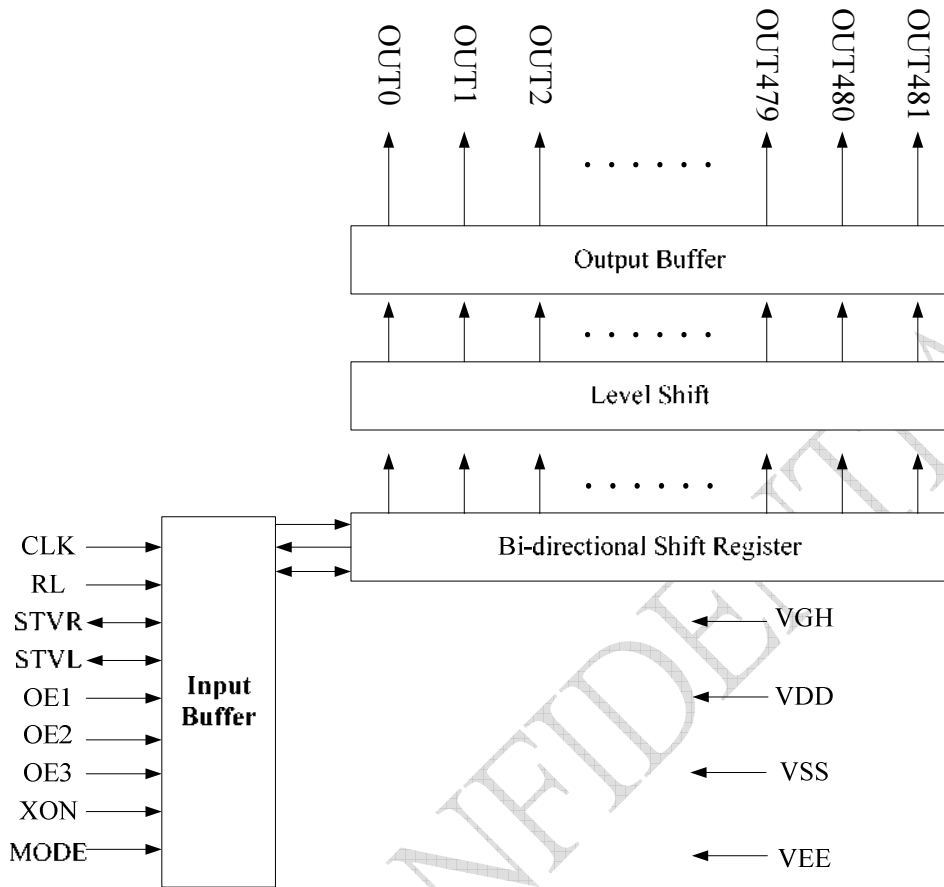

\* Note: OUT0 and OUT481 are LCD panel auxiliary pins. These pins always output VEE.

## 4. Pin Descriptions

Pin Name	I/O	Function	Descriptions									
CLK	I	Shift clock input	This is the clock input for chip internal shift register. Data is shifted at each rising edge of this clock.									
RL	I	Shift direction control pin	This pin controls the output shifting direction as listed below. RL =H:STVROUT1OUT2 • • • OUT480STVL RL =L:STVLOUT480 • • • OUT2OUT1STVR									
STVR STVL	I/O	Start pulse input/output pin	These two pins are the device start pulse input or output pin. The function of these two pins depends on the status of RL pin. <table border="1" style="margin-left: 20px;"> <thead> <tr> <th></th> <th>STV R</th> <th>STVL</th> </tr> </thead> <tbody> <tr> <td>RL=H</td> <td>input</td> <td>output</td> </tr> <tr> <td>RL=L</td> <td>output</td> <td>input</td> </tr> </tbody> </table>		STV R	STVL	RL=H	input	output	RL=L	output	input
	STV R	STVL										
RL=H	input	output										
RL=L	output	input										
OE1 OE2 OE3	I	Output enable control	These three pins are used to control the driver output. When OE1 ~ OE3 input are H, driver output is fixed to VEE regardless CLK. However, the internal shift register is not cleared even if OE1 ~ OE3 input are inactive									
XON	I	Output all-on control	When XON input pin is L, all the output pins are forced to VGH level. Note that this pin has higher priority than OE. Also it has an internal pull high resistor, keep it to VDD is preferred when unused. The chip internal shift register is not cleared when XON input is active.									
MODE	I	Output Channel number selection	They is the output channel number selection pin: <table border="1" style="margin-left: 20px;"> <thead> <tr> <th>MODE</th> <th>Output</th> </tr> </thead> <tbody> <tr> <td>L</td> <td>320 channels</td> </tr> <tr> <td>H</td> <td>480 channels</td> </tr> </tbody> </table>	MODE	Output	L	320 channels	H	480 channels			
MODE	Output											
L	320 channels											
H	480 channels											
OUT1 ~ OUT480	O	Driver output pins for driving gate electrode of LCD	The output voltage is either VGH or VEE for driving the gate electrode of TFT LCD panel depending on the data stored in shift register and the state of OE									
OUT0 OUT481	O	Auxiliary pins	LCD panel auxiliary pins, these pins always output VEE level.									
VGH	I	Power supply	Power supply for LCM drive output High									
VDD	I	Power supply	Digital power									
VSS	I	Power supply	Digital ground									
VEE	I	Power supply	Power supply for LCM drive output low.									
PASS	I	Internal link	Linked together internal.									

## 5. Operation Description

Device operation principle

In the condition of MODE=H & RL=H, the STVR start pulse input is sensed at the rising edge of CLK and stored in the first stage of shift register, which causes the first scan signal is outputted from the OUT1 output pin. While stored data is transferred to the next stage shift register at the rising edge of next CLK, new data of STVR is sensed and stored simultaneously.

The output pin (OUT1 to OUT480) supplies VGH voltage or VEE voltage to the LCD panel depending on the data stored in the shift register. For normal operation, a VGH voltage is outputted one by one from OUT1 to OUT480 in sync with CLK pulse. After 480 CLK rising edge are past, the STVL goes up to high level at the 480th falling edge of CLK and goes down to low level at the 481st falling edge of CLK. This STVL output signal becomes the STVR start pulse input of next cascaded gate driver device.

During any H state of OE, the corresponding output channels are forced to VEE level regardless of CLK. The channel output returns to normal status as soon as OE go back to L.

The mechanism is as shown below!

Device operation

MODE=H, RL=H

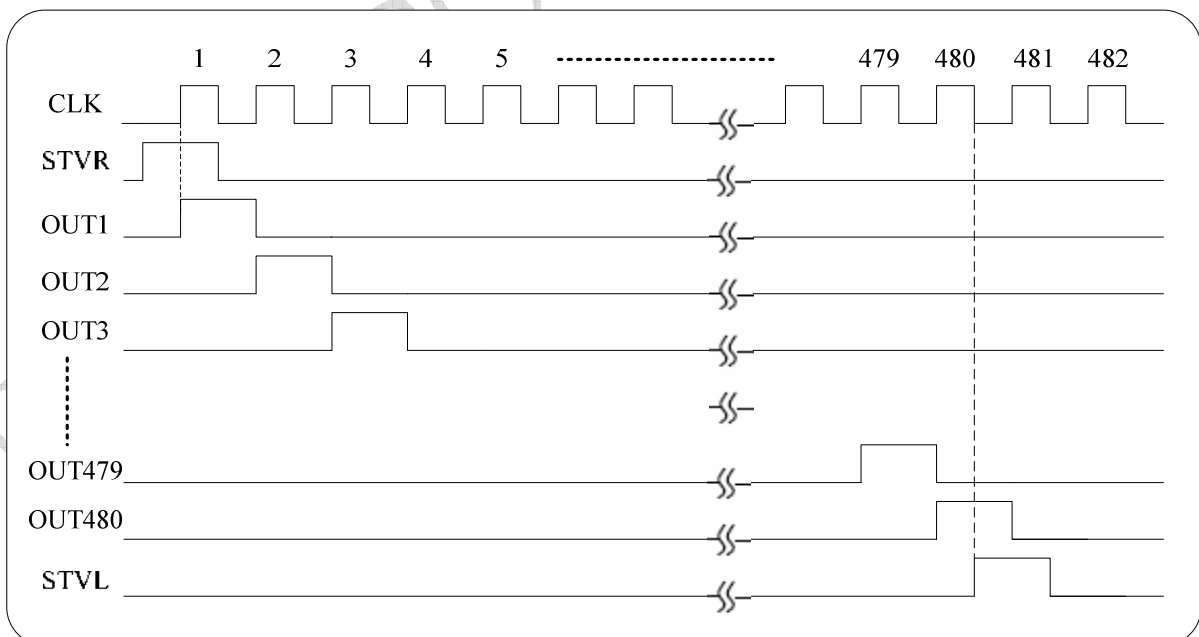

MODE=H, RL=L

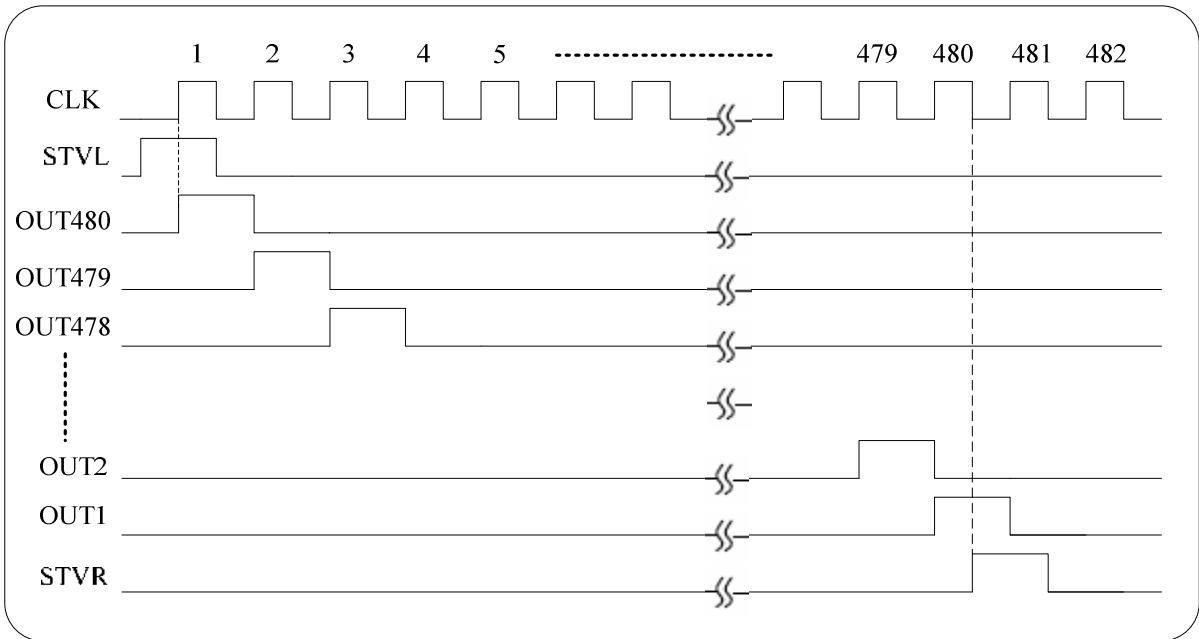

MODE=H, RL=H with OE and XON

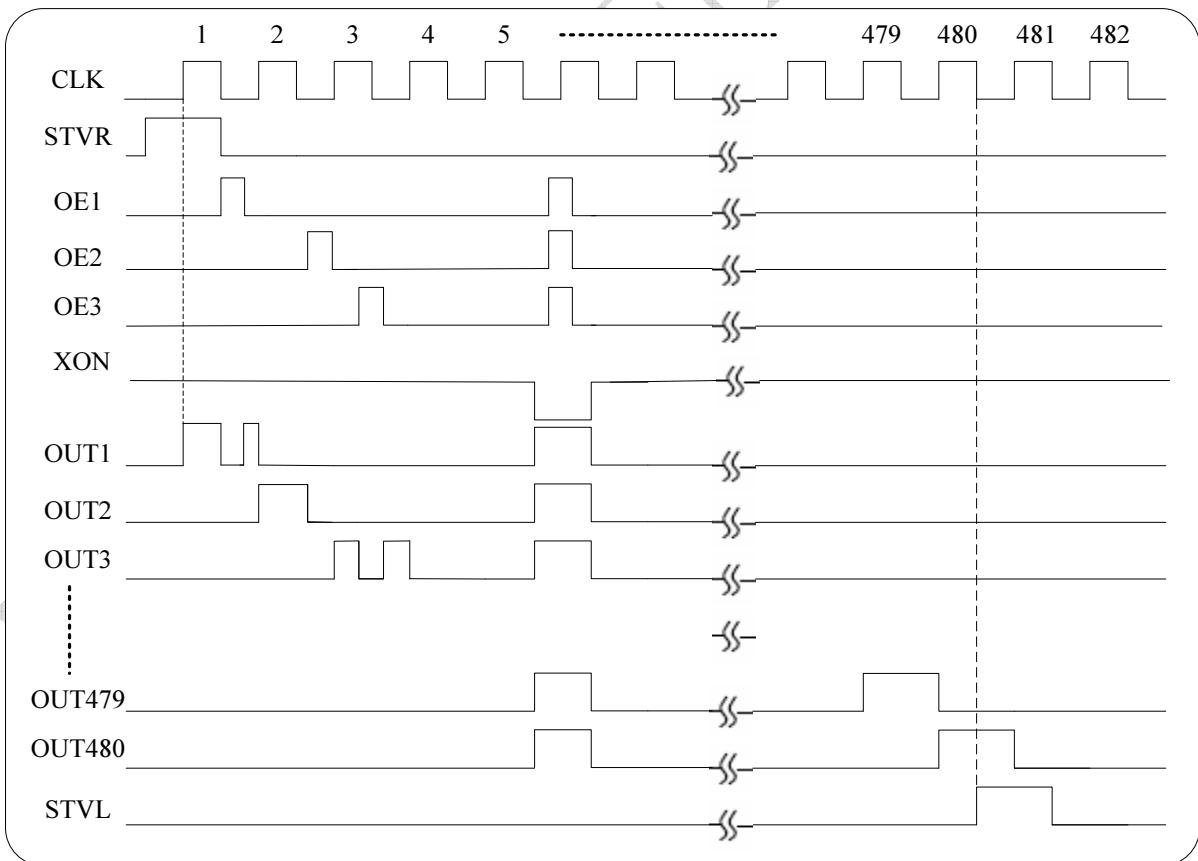

Mode (output channel) selection

Output channel number can choose between 320 and 480 by MODE pin. The following table explains the relationship!

Output Channel	MODE=L		MODE=H	
	320CH	Output control	480CH	Output control
OUT1	1st	OE1	1st	OE1
OUT2	2nd	OE2	2nd	OE2
OUT3	3rd	OE3	3rd	OE3
:	:	:	:	:
OUT160	160th	OE1	160th	OE1
OUT161	Fix to VEE	:	161st	OE2
OUT162	Fix to VEE	:	162nd	OE3
OUT163	Fix to VEE	:	163rd	OE1
:	:	:	:	:
OUT201	Fix to VEE	:	201st	OE3
OUT202	Fix to VEE	:	202nd	OE1
OUT203	Fix to VEE	:	203rd	OE2
OUT204	Fix to VEE	:	204th	OE3
:	:	:	:	:
OUT279	Fix to VEE	:	279th	OE3
OUT280	Fix to VEE	:	280th	OE1
OUT281	Fix to VEE	:	281st	OE2
OUT282	Fix to VEE	:	282nd	OE3
:	:	:	:	:
OUT320	Fix to VEE	:	320th	OE2
OUT321	161st	OE2	321st	OE3
OUT322	162nd	OE3	322nd	OE1
OUT323	163rd	OE1	323rd	OE2
:	:	:	:	:
OUT479	319th	OE1	479th	OE2
OUT480	320th	OE2	480th	OE3



Relationship between RL, STVR and STVL

RL	Start pulse		Data transfer direction
	Input	Output	
H	STVR	STVL	OUT1→OUT2→OUT3→ ●●●→OUT480
L	STVL	STVR	OUT480→OUT479→OUT478→ ●●●→OUT1

Device power supply

The input signal level of CLK, RL, OE, STVR and STVL have to swing between VDD and VSS. The signal output level of start pulse (STVR or STVL) to the next stage cascaded device is VDD for H and VSS for L. The following conditions should be followed.

$V_{GH} - V_{EE} = 40V$  (max)

$V_{GH} - V_{SS} = 7\sim 35V$

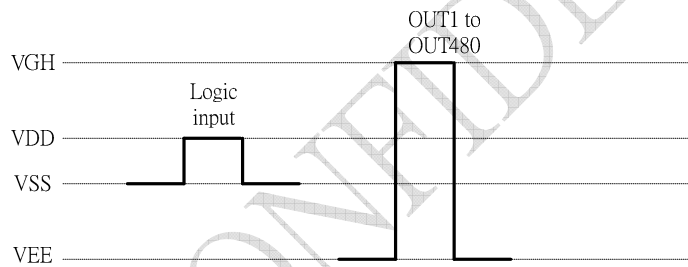

Power ON/OFF Sequence

To prevent the device damage from latch up, the power ON/OFF sequence shown below must be followed.

Power ON : VDD → VEE → VGH

Power OFF: VGH → VEE → VDD

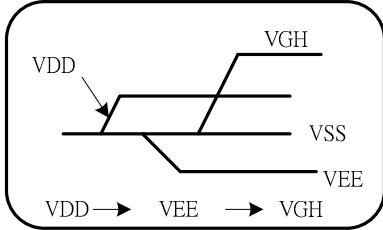

Power ON Sequence

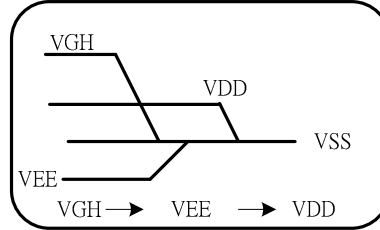

Power OFF Sequence

Power ON: VDD → VGH → VEE

Power OFF: VEE → VGH → VDD

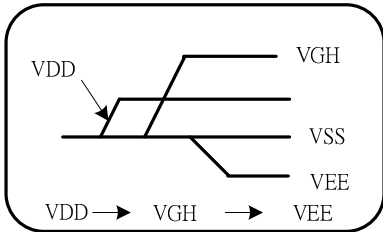

Power ON Sequence

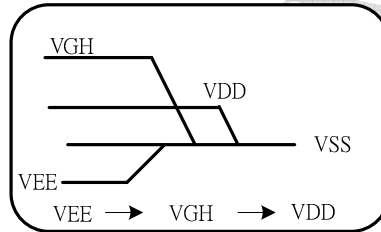

Power OFF Sequence

**Power on sequence (VDD → VEE → VGH)**

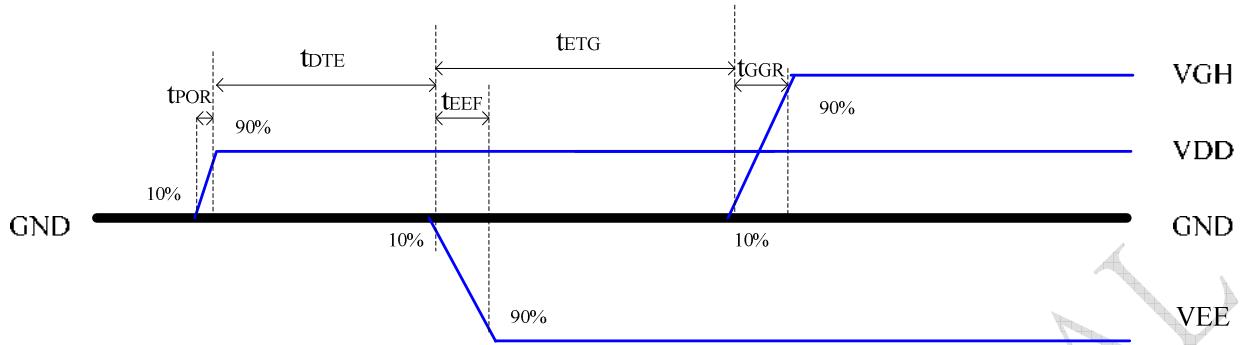

**Power on sequence (VDD → VGH → VEE)**

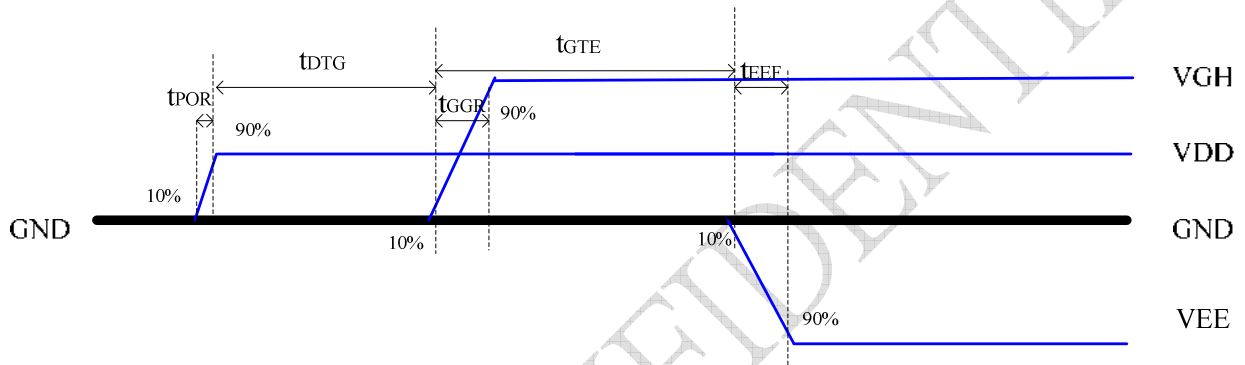

**Power off sequence (VGH → VEE → VDD)**

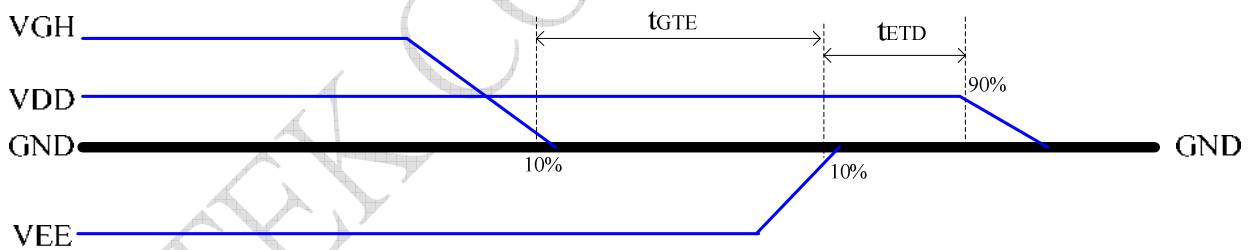

**Power off sequence (VEE → VGH → VDD)**

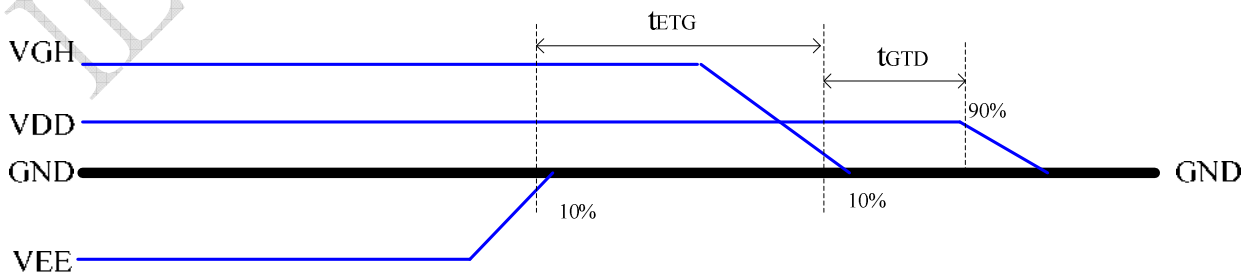

## 6. DC Characteristic

Absolute Maximum Rating (GND = VSS=0V)

Parameter	Symbol	Rating	Unit
Power supply voltage (1)	VGH	-0.3 to 42.0	V
Power supply voltage (2)	VDD	-0.3 to 7.0	V
Power supply voltage (3)	VEE	VGH-42 to 0.3	V
Input voltage	Vin	-0.3 to VDD+0.3	V
Storage temperature	TSTG	-55 to 125	°C

**Note:**

(1)All of the voltages listed above are with respective to GND=VSS=0V.

(2)Device is subject to be damaged permanently if stresses beyond those absolute maximum ratings listed above.

Recommended operating conditions (GND=VSS=0V)

Parameter	Symbol	Rating			Unit
		Min	Typ	Max	
Power supply voltage (1)	VGH	7	-	VEE+40	V
Power supply voltage (2)	VDD	2.3	3.3	5.5	V
Power supply voltage (3)	VEE	-20	-	-5	V
Power supply voltage (4)	VGH-VEE	12	-	40	V
Operation frequency	FCLK	-	-	200	K Hz
Operation temperature	Ta	-40	-	+95	°C

Electrical Characteristics (GND=VSS=0V)

Parameter	Symbol	Condition	Rating			Unit	Application pin
			Min	Typ	Max		
Input H voltage	V <sub>IH</sub>	-	0.7VDD	-	VDD	V	All input
Input L voltage	V <sub>IL</sub>	-	VSS	-	0.3VDD	V	All input
Output H voltage	V <sub>OH</sub>	I <sub>OH</sub> =40μA	VDD-0.4	-	VDD	V	STVR,L
Output L voltage)	V <sub>OL</sub>	I <sub>OL</sub> =40μA	VSS	-	VSS+0.4	V	STVR,L
Output H resistance	R <sub>OH</sub>	V <sub>OUT</sub> = VGH-0.5V	-	-	1000	Ω	OUT0~481
Output L resistance	R <sub>OL</sub>	V <sub>OUT</sub> = VEE+0.5V	-	-	1000	Ω	OUT0~481
Input leakage current	I <sub>IN</sub>	-	-5	-	+5	μA	Note (b)
Pull high resistance	R <sub>PU</sub>	V <sub>IN</sub> =VSS	40	-	200	kΩ	XON
VGH Power consumption	I <sub>VGH</sub>	Note (a)	-	-	100	μA	-
VGH Power consumption	I <sub>VDD</sub>	Note (a)	-	-	100	μA	-

Note

(a) Power consumption with the following condition: Output no load, VGH=20V, VEE= -8V, VDD=3.0V, V<sub>IH</sub>=VDD, V<sub>IL</sub>=VSS, F<sub>CPV</sub>=50 kHz, OE=V<sub>IL</sub>, XON=V<sub>IH</sub>.

(b) All input except XON

## 7. AC Characteristic

### AC Electrical Characteristics

Parameter	Symbol	Condition	Spec			Unit
			Min	Typ	Max	
CLK period	tCLK	-	5	-	-	μs
CLK pulse width	tCLKH, tCLKL	50% duty cycle	2.5	-	-	μs
OE pulse width	tWOE	-	1	-	-	μs
XON pulse width	txon	-	10	-	-	μs
Data setup time	tsu	-	0.7	-	-	μs
Data hold time	tHD	-	0.7	-	-	μs
CLK to output delay time	tPD1	CL=300pF	-	-	1	μs
Start pulse output delay time	tPD2	CL=30pF	-	-	0.8	μs
OE to output delay time	tPD3	CL=300pF	-	-	0.8	μs
XON to output delay time	tPD4	CL=300pF	-	-	10	μs
Power-On Reset Slew Time	tpor	From 10% to 90% VDD	-	-	-	ms
VDD to VEE Time	tdte	From 10% VDD to 90% VEE	0	-	-	ms
VEE to VDD Time	tetd	From 10% VEE to 90% VDD	0	-	-	ms
VEE to VGH Time	tetg	From 10% VEE to 10% VGH	1	-	-	ms
VGH to VEE Time	tgte	From 10% VGH to 10% VEE	1	-	-	ms
VGH Rising Time	tggr (1)	From 10% to 90% VGH	teef	-	-	ms

Note(1):teef=> VEE Falling Time, From 10% to 90% VEE

## 8. Timing Chart

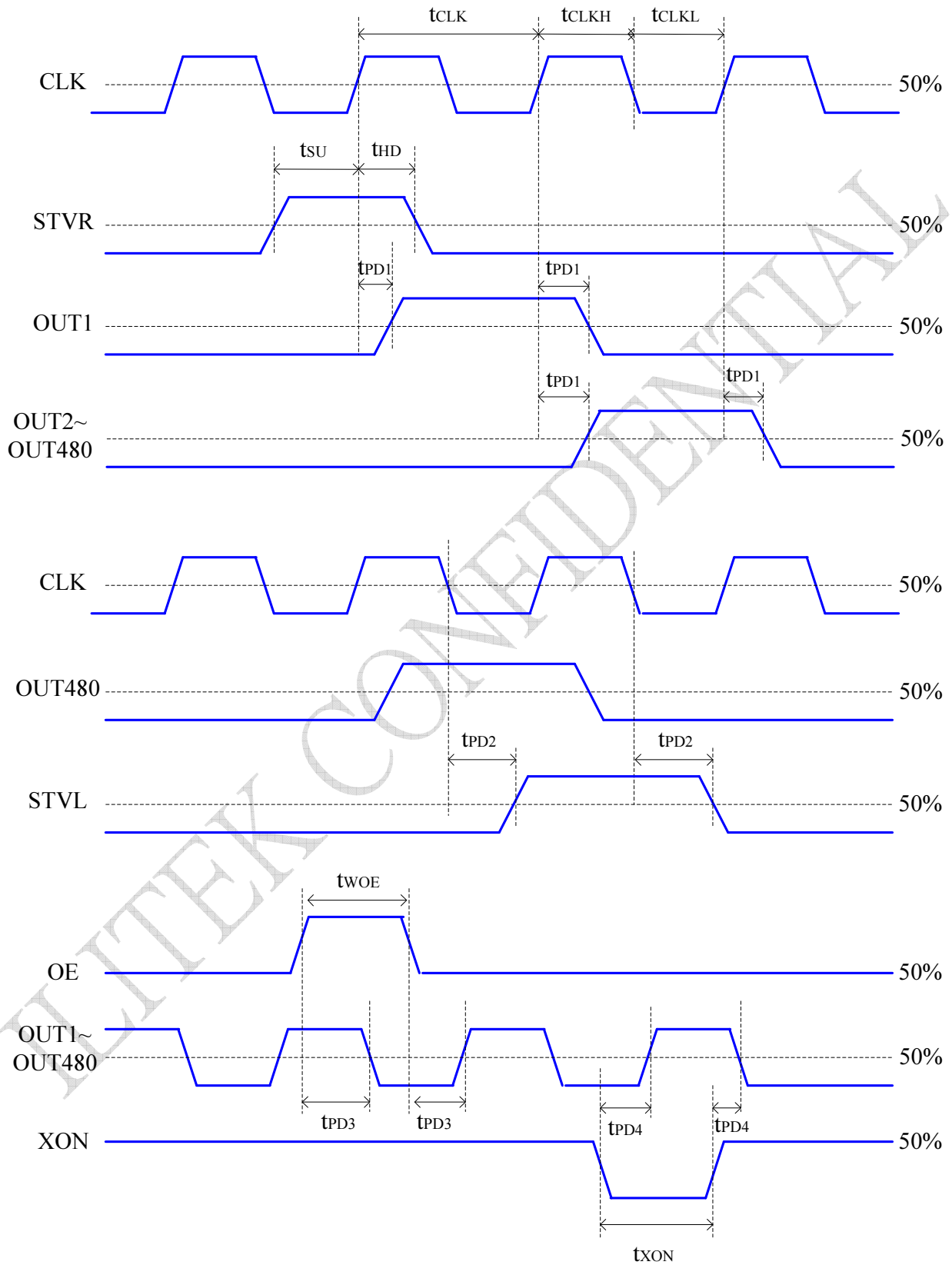

## 9. Pin Assignment (IC Face View)

Chip Size: 13530um x 1047um  
Chip thickness : 400um (typ.)  
Pad Location: Pad Center.  
Coordinate Origin: Chip center  
Au bump height: 15um (typ.)

Au Bump Size:

1. 25 um x 84 um  
pin number: 1 ~ 484
2. 50 um x 45 um  
pin number: 485 ~ 514, 632~661
3. 40 um x 85 um  
pin number: 515 ~ 537, 609~631
4. 105 um x 85 um  
pin number: 538 ~ 608

Alignment Marks

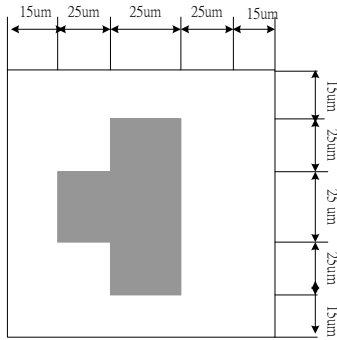

Alignment Mark: Left

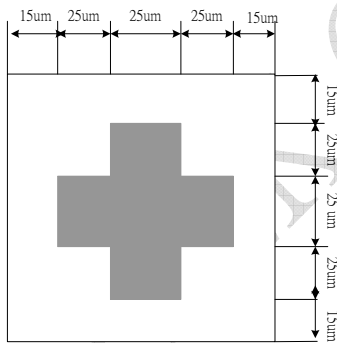

Alignment Mark: Right

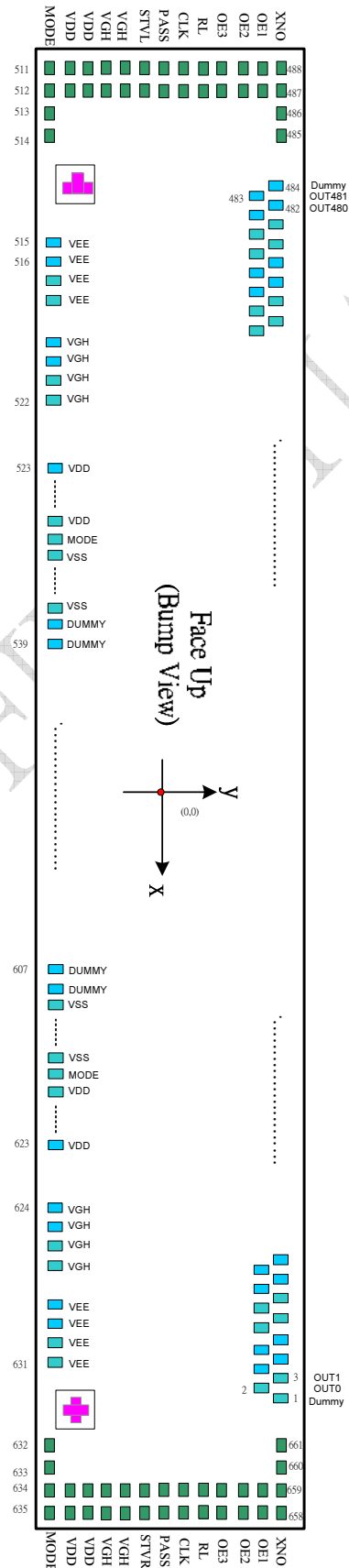
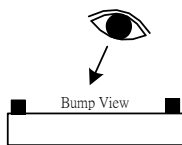



## 10. Pad Location

No.	Name	X	Y	No.	Name	X	Y	No.	Name	X	Y
1	DUMMY	6050	406.5	61	OUT59	4525	287.5	121	OUT119	3025	287.5
2	OUT0	6000	406.5	62	OUT60	4500	406.5	122	OUT120	3000	406.5
3	OUT1	5975	287.5	63	OUT61	4475	287.5	123	OUT121	2975	287.5
4	OUT2	5950	406.5	64	OUT62	4450	406.5	124	OUT122	2950	406.5
5	OUT3	5925	287.5	65	OUT63	4425	287.5	125	OUT123	2925	287.5
6	OUT4	5900	406.5	66	OUT64	4400	406.5	126	OUT124	2900	406.5
7	OUT5	5875	287.5	67	OUT65	4375	287.5	127	OUT125	2875	287.5
8	OUT6	5850	406.5	68	OUT66	4350	406.5	128	OUT126	2850	406.5
9	OUT7	5825	287.5	69	OUT67	4325	287.5	129	OUT127	2825	287.5
10	OUT8	5800	406.5	70	OUT68	4300	406.5	130	OUT128	2800	406.5
11	OUT9	5775	287.5	71	OUT69	4275	287.5	131	OUT129	2775	287.5
12	OUT10	5750	406.5	72	OUT70	4250	406.5	132	OUT130	2750	406.5
13	OUT11	5725	287.5	73	OUT71	4225	287.5	133	OUT131	2725	287.5
14	OUT12	5700	406.5	74	OUT72	4200	406.5	134	OUT132	2700	406.5
15	OUT13	5675	287.5	75	OUT73	4175	287.5	135	OUT133	2675	287.5
16	OUT14	5650	406.5	76	OUT74	4150	406.5	136	OUT134	2650	406.5
17	OUT15	5625	287.5	77	OUT75	4125	287.5	137	OUT135	2625	287.5
18	OUT16	5600	406.5	78	OUT76	4100	406.5	138	OUT136	2600	406.5
19	OUT17	5575	287.5	79	OUT77	4075	287.5	139	OUT137	2575	287.5
20	OUT18	5550	406.5	80	OUT78	4050	406.5	140	OUT138	2550	406.5
21	OUT19	5525	287.5	81	OUT79	4025	287.5	141	OUT139	2525	287.5
22	OUT20	5500	406.5	82	OUT80	4000	406.5	142	OUT140	2500	406.5
23	OUT21	5475	287.5	83	OUT81	3975	287.5	143	OUT141	2475	287.5
24	OUT22	5450	406.5	84	OUT82	3950	406.5	144	OUT142	2450	406.5
25	OUT23	5425	287.5	85	OUT83	3925	287.5	145	OUT143	2425	287.5
26	OUT24	5400	406.5	86	OUT84	3900	406.5	146	OUT144	2400	406.5
27	OUT25	5375	287.5	87	OUT85	3875	287.5	147	OUT145	2375	287.5
28	OUT26	5350	406.5	88	OUT86	3850	406.5	148	OUT146	2350	406.5
29	OUT27	5325	287.5	89	OUT87	3825	287.5	149	OUT147	2325	287.5
30	OUT28	5300	406.5	90	OUT88	3800	406.5	150	OUT148	2300	406.5
31	OUT29	5275	287.5	91	OUT89	3775	287.5	151	OUT149	2275	287.5
32	OUT30	5250	406.5	92	OUT90	3750	406.5	152	OUT150	2250	406.5
33	OUT31	5225	287.5	93	OUT91	3725	287.5	153	OUT151	2225	287.5
34	OUT32	5200	406.5	94	OUT92	3700	406.5	154	OUT152	2200	406.5
35	OUT33	5175	287.5	95	OUT93	3675	287.5	155	OUT153	2175	287.5
36	OUT34	5150	406.5	96	OUT94	3650	406.5	156	OUT154	2150	406.5
37	OUT35	5125	287.5	97	OUT95	3625	287.5	157	OUT155	2125	287.5
38	OUT36	5100	406.5	98	OUT96	3600	406.5	158	OUT156	2100	406.5
39	OUT37	5075	287.5	99	OUT97	3575	287.5	159	OUT157	2075	287.5
40	OUT38	5050	406.5	100	OUT98	3550	406.5	160	OUT158	2050	406.5
41	OUT39	5025	287.5	101	OUT99	3525	287.5	161	OUT159	2025	287.5
42	OUT40	5000	406.5	102	OUT100	3500	406.5	162	OUT160	2000	406.5
43	OUT41	4975	287.5	103	OUT101	3475	287.5	163	OUT161	1975	287.5
44	OUT42	4950	406.5	104	OUT102	3450	406.5	164	OUT162	1950	406.5
45	OUT43	4925	287.5	105	OUT103	3425	287.5	165	OUT163	1925	287.5
46	OUT44	4900	406.5	106	OUT104	3400	406.5	166	OUT164	1900	406.5
47	OUT45	4875	287.5	107	OUT105	3375	287.5	167	OUT165	1875	287.5
48	OUT46	4850	406.5	108	OUT106	3350	406.5	168	OUT166	1850	406.5
49	OUT47	4825	287.5	109	OUT107	3325	287.5	169	OUT167	1825	287.5
50	OUT48	4800	406.5	110	OUT108	3300	406.5	170	OUT168	1800	406.5
51	OUT49	4775	287.5	111	OUT109	3275	287.5	171	OUT169	1775	287.5
52	OUT50	4750	406.5	112	OUT110	3250	406.5	172	OUT170	1750	406.5
53	OUT51	4725	287.5	113	OUT111	3225	287.5	173	OUT171	1725	287.5
54	OUT52	4700	406.5	114	OUT112	3200	406.5	174	OUT172	1700	406.5
55	OUT53	4675	287.5	115	OUT113	3175	287.5	175	OUT173	1675	287.5
56	OUT54	4650	406.5	116	OUT114	3150	406.5	176	OUT174	1650	406.5
57	OUT55	4625	287.5	117	OUT115	3125	287.5	177	OUT175	1625	287.5
58	OUT56	4600	406.5	118	OUT116	3100	406.5	178	OUT176	1600	406.5
59	OUT57	4575	287.5	119	OUT117	3075	287.5	179	OUT177	1575	287.5
60	OUT58	4550	406.5	120	OUT118	3050	406.5	180	OUT178	1550	406.5

No.	Name	X	Y	No.	Name	X	Y	No.	Name	X	Y
181	OUT179	1525	287.5	241	OUT239	25	287.5	301	OUT299	-1475	287.5
182	OUT180	1500	406.5	242	OUT240	0	406.5	302	OUT300	-1500	406.5
183	OUT181	1475	287.5	243	OUT241	-25	287.5	303	OUT301	-1525	287.5
184	OUT182	1450	406.5	244	OUT242	-50	406.5	304	OUT302	-1550	406.5
185	OUT183	1425	287.5	245	OUT243	-75	287.5	305	OUT303	-1575	287.5
186	OUT184	1400	406.5	246	OUT244	-100	406.5	306	OUT304	-1600	406.5
187	OUT185	1375	287.5	247	OUT245	-125	287.5	307	OUT305	-1625	287.5
188	OUT186	1350	406.5	248	OUT246	-150	406.5	308	OUT306	-1650	406.5
189	OUT187	1325	287.5	249	OUT247	-175	287.5	309	OUT307	-1675	287.5
190	OUT188	1300	406.5	250	OUT248	-200	406.5	310	OUT308	-1700	406.5
191	OUT189	1275	287.5	251	OUT249	-225	287.5	311	OUT309	-1725	287.5
192	OUT190	1250	406.5	252	OUT250	-250	406.5	312	OUT310	-1750	406.5
193	OUT191	1225	287.5	253	OUT251	-275	287.5	313	OUT311	-1775	287.5
194	OUT192	1200	406.5	254	OUT252	-300	406.5	314	OUT312	-1800	406.5
195	OUT193	1175	287.5	255	OUT253	-325	287.5	315	OUT313	-1825	287.5
196	OUT194	1150	406.5	256	OUT254	-350	406.5	316	OUT314	-1850	406.5
197	OUT195	1125	287.5	257	OUT255	-375	287.5	317	OUT315	-1875	287.5
198	OUT196	1100	406.5	258	OUT256	-400	406.5	318	OUT316	-1900	406.5
199	OUT197	1075	287.5	259	OUT257	-425	287.5	319	OUT317	-1925	287.5
200	OUT198	1050	406.5	260	OUT258	-450	406.5	320	OUT318	-1950	406.5
201	OUT199	1025	287.5	261	OUT259	-475	287.5	321	OUT319	-1975	287.5
202	OUT200	1000	406.5	262	OUT260	-500	406.5	322	OUT320	-2000	406.5
203	OUT201	975	287.5	263	OUT261	-525	287.5	323	OUT321	-2025	287.5
204	OUT202	950	406.5	264	OUT262	-550	406.5	324	OUT322	-2050	406.5
205	OUT203	925	287.5	265	OUT263	-575	287.5	325	OUT323	-2075	287.5
206	OUT204	900	406.5	266	OUT264	-600	406.5	326	OUT324	-2100	406.5
207	OUT205	875	287.5	267	OUT265	-625	287.5	327	OUT325	-2125	287.5
208	OUT206	850	406.5	268	OUT266	-650	406.5	328	OUT326	-2150	406.5
209	OUT207	825	287.5	269	OUT267	-675	287.5	329	OUT327	-2175	287.5
210	OUT208	800	406.5	270	OUT268	-700	406.5	330	OUT328	-2200	406.5
211	OUT209	775	287.5	271	OUT269	-725	287.5	331	OUT329	-2225	287.5
212	OUT210	750	406.5	272	OUT270	-750	406.5	332	OUT330	-2250	406.5
213	OUT211	725	287.5	273	OUT271	-775	287.5	333	OUT331	-2275	287.5
214	OUT212	700	406.5	274	OUT272	-800	406.5	334	OUT332	-2300	406.5
215	OUT213	675	287.5	275	OUT273	-825	287.5	335	OUT333	-2325	287.5
216	OUT214	650	406.5	276	OUT274	-850	406.5	336	OUT334	-2350	406.5
217	OUT215	625	287.5	277	OUT275	-875	287.5	337	OUT335	-2375	287.5
218	OUT216	600	406.5	278	OUT276	-900	406.5	338	OUT336	-2400	406.5
219	OUT217	575	287.5	279	OUT277	-925	287.5	339	OUT337	-2425	287.5
220	OUT218	550	406.5	280	OUT278	-950	406.5	340	OUT338	-2450	406.5
221	OUT219	525	287.5	281	OUT279	-975	287.5	341	OUT339	-2475	287.5
222	OUT220	500	406.5	282	OUT280	-1000	406.5	342	OUT340	-2500	406.5
223	OUT221	475	287.5	283	OUT281	-1025	287.5	343	OUT341	-2525	287.5
224	OUT222	450	406.5	284	OUT282	-1050	406.5	344	OUT342	-2550	406.5
225	OUT223	425	287.5	285	OUT283	-1075	287.5	345	OUT343	-2575	287.5
226	OUT224	400	406.5	286	OUT284	-1100	406.5	346	OUT344	-2600	406.5
227	OUT225	375	287.5	287	OUT285	-1125	287.5	347	OUT345	-2625	287.5
228	OUT226	350	406.5	288	OUT286	-1150	406.5	348	OUT346	-2650	406.5
229	OUT227	325	287.5	289	OUT287	-1175	287.5	349	OUT347	-2675	287.5
230	OUT228	300	406.5	290	OUT288	-1200	406.5	350	OUT348	-2700	406.5
231	OUT229	275	287.5	291	OUT289	-1225	287.5	351	OUT349	-2725	287.5
232	OUT230	250	406.5	292	OUT290	-1250	406.5	352	OUT350	-2750	406.5
233	OUT231	225	287.5	293	OUT291	-1275	287.5	353	OUT351	-2775	287.5
234	OUT232	200	406.5	294	OUT292	-1300	406.5	354	OUT352	-2800	406.5
235	OUT233	175	287.5	295	OUT293	-1325	287.5	355	OUT353	-2825	287.5
236	OUT234	150	406.5	296	OUT294	-1350	406.5	356	OUT354	-2850	406.5
237	OUT235	125	287.5	297	OUT295	-1375	287.5	357	OUT355	-2875	287.5
238	OUT236	100	406.5	298	OUT296	-1400	406.5	358	OUT356	-2900	406.5
239	OUT237	75	287.5	299	OUT297	-1425	287.5	359	OUT357	-2925	287.5
240	OUT238	50	406.5	300	OUT298	-1450	406.5	360	OUT358	-2950	406.5

No.	Name	X	Y
361	OUT359	-2975	287.5
362	OUT360	-3000	406.5
363	OUT361	-3025	287.5
364	OUT362	-3050	406.5
365	OUT363	-3075	287.5
366	OUT364	-3100	406.5
367	OUT365	-3125	287.5
368	OUT366	-3150	406.5
369	OUT367	-3175	287.5
370	OUT368	-3200	406.5
371	OUT369	-3225	287.5
372	OUT370	-3250	406.5
373	OUT371	-3275	287.5
374	OUT372	-3300	406.5
375	OUT373	-3325	287.5
376	OUT374	-3350	406.5
377	OUT375	-3375	287.5
378	OUT376	-3400	406.5
379	OUT377	-3425	287.5
380	OUT378	-3450	406.5
381	OUT379	-3475	287.5
382	OUT380	-3500	406.5
383	OUT381	-3525	287.5
384	OUT382	-3550	406.5
385	OUT383	-3575	287.5
386	OUT384	-3600	406.5
387	OUT385	-3625	287.5
388	OUT386	-3650	406.5
389	OUT387	-3675	287.5
390	OUT388	-3700	406.5
391	OUT389	-3725	287.5
392	OUT390	-3750	406.5
393	OUT391	-3775	287.5
394	OUT392	-3800	406.5
395	OUT393	-3825	287.5
396	OUT394	-3850	406.5
397	OUT395	-3875	287.5
398	OUT396	-3900	406.5
399	OUT397	-3925	287.5
400	OUT398	-3950	406.5
401	OUT399	-3975	287.5
402	OUT400	-4000	406.5
403	OUT401	-4025	287.5
404	OUT402	-4050	406.5
405	OUT403	-4075	287.5
406	OUT404	-4100	406.5
407	OUT405	-4125	287.5
408	OUT406	-4150	406.5
409	OUT407	-4175	287.5
410	OUT408	-4200	406.5
411	OUT409	-4225	287.5
412	OUT410	-4250	406.5
413	OUT411	-4275	287.5
414	OUT412	-4300	406.5
415	OUT413	-4325	287.5
416	OUT414	-4350	406.5
417	OUT415	-4375	287.5
418	OUT416	-4400	406.5
419	OUT417	-4425	287.5
420	OUT418	-4450	406.5

No.	Name	X	Y
421	OUT419	-4475	287.5
422	OUT420	-4500	406.5
423	OUT421	-4525	287.5
424	OUT422	-4550	406.5
425	OUT423	-4575	287.5
426	OUT424	-4600	406.5
427	OUT425	-4625	287.5
428	OUT426	-4650	406.5
429	OUT427	-4675	287.5
430	OUT428	-4700	406.5
431	OUT429	-4725	287.5
432	OUT430	-4750	406.5
433	OUT431	-4775	287.5
434	OUT432	-4800	406.5
435	OUT433	-4825	287.5
436	OUT434	-4850	406.5
437	OUT435	-4875	287.5
438	OUT436	-4900	406.5
439	OUT437	-4925	287.5
440	OUT438	-4950	406.5
441	OUT439	-4975	287.5
442	OUT440	-5000	406.5
443	OUT441	-5025	287.5
444	OUT442	-5050	406.5
445	OUT443	-5075	287.5
446	OUT444	-5100	406.5
447	OUT445	-5125	287.5
448	OUT446	-5150	406.5
449	OUT447	-5175	287.5
450	OUT448	-5200	406.5
451	OUT449	-5225	287.5
452	OUT450	-5250	406.5
453	OUT451	-5275	287.5
454	OUT452	-5300	406.5
455	OUT453	-5325	287.5
456	OUT454	-5350	406.5
457	OUT455	-5375	287.5
458	OUT456	-5400	406.5
459	OUT457	-5425	287.5
460	OUT458	-5450	406.5
461	OUT459	-5475	287.5
462	OUT460	-5500	406.5
463	OUT461	-5525	287.5
464	OUT462	-5550	406.5
465	OUT463	-5575	287.5
466	OUT464	-5600	406.5
467	OUT465	-5625	287.5
468	OUT466	-5650	406.5
469	OUT467	-5675	287.5
470	OUT468	-5700	406.5
471	OUT469	-5725	287.5
472	OUT470	-5750	406.5
473	OUT471	-5775	287.5
474	OUT472	-5800	406.5
475	OUT473	-5825	287.5
476	OUT474	-5850	406.5
477	OUT475	-5875	287.5
478	OUT476	-5900	406.5
479	OUT477	-5925	287.5
480	OUT478	-5950	406.5

No.	Name	X	Y
481	OUT479	-5975	287.5
482	OUT480	-6000	406.5
483	OUT481	-6025	287.5
484	DUMMY	-6050	406.5
485	XON	-6470	426
486	XON	-6535	426
487	XON	-6600	426
488	XON	-6665	426
489	OE1	-6600	355
490	OE1	-6665	355
491	OE2	-6600	284
492	OE2	-6665	284
493	OE3	-6600	213
494	OE3	-6665	213
495	RL	-6600	142
496	RL	-6665	142
497	CLK	-6600	71
498	CLK	-6665	71
499	PATH	-6600	0
500	PATH	-6665	0
501	STVL	-6600	-71
502	STVL	-6665	-71
503	VGH	-6600	-142
504	VGH	-6665	-142
505	VGH	-6600	-213
506	VGH	-6665	-213
507	VDD	-6600	-284
508	VDD	-6665	-284
509	VDD	-6600	-355
510	VDD	-6665	-355
511	MODE	-6470	-426
512	MODE	-6535	-426
513	MODE	-6600	-426
514	MODE	-6665	-426
515	VEE	-6094	-406
516	VEE	-6042	-406
517	VEE	-5990	-406
518	VEE	-5938	-406
519	VGH	-5858	-406
520	VGH	-5806	-406
521	VGH	-5754	-406
522	VGH	-5702	-406
523	VDD	-5622	-406
524	VDD	-5570	-406
525	VDD	-5518	-406
526	VDD	-5466	-406
527	MODE	-5386	-406
528	VSS	-5306	-406
529	VSS	-5254	-406
530	VSS	-5202	-406
531	VSS	-5150	-406
532	VSS	-5098	-406
533	VSS	-5046	-406
534	VSS	-4994	-406
535	VSS	-4942	-406
536	VSS	-4890	-406
537	VSS	-4838	-406
538	DUMMY	-4725	-406
539	DUMMY	-4590	-406
540	DUMMY	-4455	-406

No.	Name	X	Y
541	DUMMY	-4320	-406
542	DUMMY	-4185	-406
543	DUMMY	-4050	-406
544	DUMMY	-3915	-406
545	DUMMY	-3780	-406
546	DUMMY	-3645	-406
547	DUMMY	-3510	-406
548	DUMMY	-3375	-406
549	DUMMY	-3240	-406
550	DUMMY	-3105	-406
551	DUMMY	-2970	-406
552	DUMMY	-2835	-406
553	DUMMY	-2700	-406
554	DUMMY	-2565	-406
555	DUMMY	-2430	-406
556	DUMMY	-2295	-406
557	DUMMY	-2160	-406
558	DUMMY	-2025	-406
559	DUMMY	-1890	-406
560	DUMMY	-1755	-406
561	DUMMY	-1620	-406
562	DUMMY	-1485	-406
563	DUMMY	-1350	-406
564	DUMMY	-1215	-406
565	DUMMY	-1080	-406
566	DUMMY	-945	-406
567	DUMMY	-810	-406
568	DUMMY	-675	-406
569	DUMMY	-540	-406
570	DUMMY	-405	-406
571	DUMMY	-270	-406
572	DUMMY	-135	-406
573	DUMMY	0	-406
574	DUMMY	135	-406
575	DUMMY	270	-406
576	DUMMY	405	-406
577	DUMMY	540	-406
578	DUMMY	675	-406
579	DUMMY	810	-406
580	DUMMY	945	-406
581	DUMMY	1080	-406
582	DUMMY	1215	-406
583	DUMMY	1350	-406
584	DUMMY	1485	-406
585	DUMMY	1620	-406
586	DUMMY	1755	-406
587	DUMMY	1890	-406
588	DUMMY	2025	-406
589	DUMMY	2160	-406
590	DUMMY	2295	-406
591	DUMMY	2430	-406
592	DUMMY	2565	-406
593	DUMMY	2700	-406
594	DUMMY	2835	-406
595	DUMMY	2970	-406
596	DUMMY	3105	-406
597	DUMMY	3240	-406
598	DUMMY	3375	-406
599	DUMMY	3510	-406
600	DUMMY	3645	-406

No.	Name	X	Y
601	DUMMY	3780	-406
602	DUMMY	3915	-406
603	DUMMY	4050	-406
604	DUMMY	4185	-406
605	DUMMY	4320	-406
606	DUMMY	4455	-406
607	DUMMY	4590	-406
608	DUMMY	4725	-406
609	VSS	4838	-406
610	VSS	4890	-406
611	VSS	4942	-406
612	VSS	4994	-406
613	VSS	5046	-406
614	VSS	5098	-406
615	VSS	5150	-406
616	VSS	5202	-406
617	VSS	5254	-406
618	VSS	5306	-406
619	MODE	5386	-406
620	VDD	5466	-406
621	VDD	5518	-406
622	VDD	5570	-406
623	VDD	5622	-406
624	VGH	5702	-406
625	VGH	5754	-406
626	VGH	5806	-406
627	VGH	5858	-406
628	VEE	5938	-406
629	VEE	5990	-406
630	VEE	6042	-406
631	VEE	6094	-406
632	MODE	6470	-426
633	MODE	6535	-426
634	MODE	6600	-426
635	MODE	6665	-426
636	VDD	6600	-355
637	VDD	6665	-355
638	VDD	6600	-284
639	VDD	6665	-284
640	VGH	6600	-213
641	VGH	6665	-213
642	VGH	6600	-142
643	VGH	6665	-142
644	STVR	6600	-71
645	STVR	6665	-71
646	PATH	6600	0
647	PATH	6665	0
648	CLK	6600	71
649	CLK	6665	71
650	RL	6600	142
651	RL	6665	142
652	OE3	6600	213
653	OE3	6665	213
654	OE2	6600	284
655	OE2	6665	284
656	OE1	6600	355
657	OE1	6665	355
658	XON	6470	426
659	XON	6535	426
660	XON	6600	426
661	XON	6665	426

## 11. Bump Mask Information

- Chip size: 13530  $\mu\text{m}$  x 1047  $\mu\text{m}$  (include scribe line: 80 $\mu\text{m}$ )
- Bump height : 15  $\mu\text{m} \pm 3 \mu\text{m}$
- Bump hardness : 60 Hv  $\pm 15$  Hv

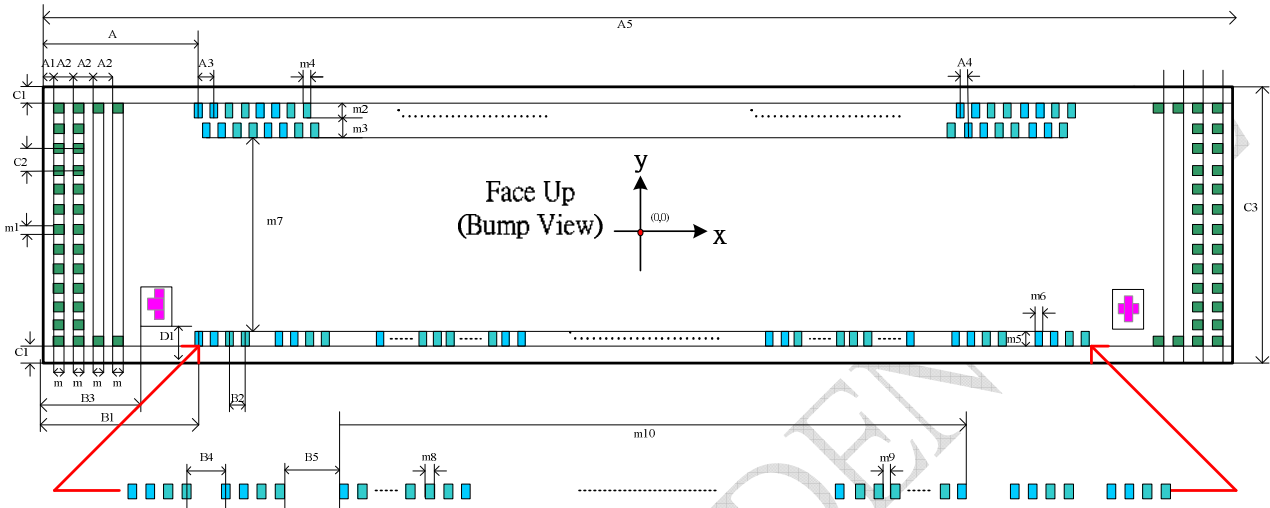

Symbol	Dimensions ( $\mu\text{m}$ )	Symbol	Dimensions ( $\mu\text{m}$ )
A	715	C3	1047
A1	75	D1	110
A2	65	m	50
A3	50	m1	45
A4	25	m2	84
A5	13530	m3	119
B1	671	m4	25
B2	52	m5	85
B3	445	m6	40
B4	80	m7	609
B5	40.5	m8	105
C1	75	m9	30
C2	71	m10	9555

Scribe line is included

Alignment Mark type and coordinate

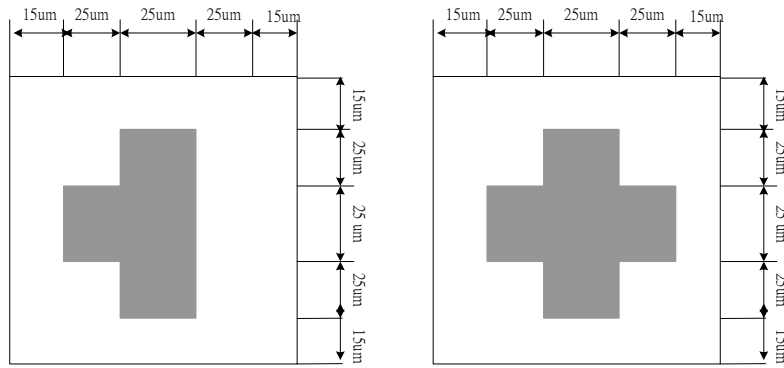

Alignment Mark: Left

Alignment Mark: Right

	X	Y
Alignment Mark Left	-6267.5	-361
Alignment Mark Right	6267.5	-361

ILITEK CONFIDENTIAL

## 12. Revision History

Version No.	Date	Page	Description
0.0	2007/12/25	all	New set up
0.01	2008/07/23	1	Modify company address
0.02	2010/04/06	10	Modify Power On-Off Sequence

ILITEK CONFIDENTIAL