

DOT MATRIX GRAPHIC LCD CONTROLLER HD61830B

The HD61830B is a dot matrix liquid crystal graphic display controller LSI that stores the display data sent from an 8-bit micro-computer in the external RAM to generate dot matrix liquid crystal driving signals.

It is possible to select the graphic mode in which the 1-bit data of the external RAM corresponds to the ON/OFF state of 1 dot on liquid crystal display and the character mode in which characters are displayed by storing character codes in the external RAM and developing them into the dot patterns with the internal character generator ROM. Both modes can be provided for various applications.

The HD61830B is produced in the CMOS process. Thus, the combination with a CMOS microcomputer can accomplish a liquid crystal display device with lower power dissipation.

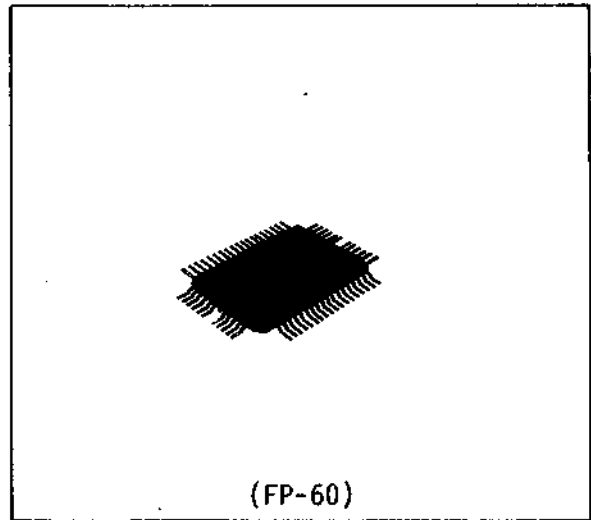

PIN ARRANGEMENT

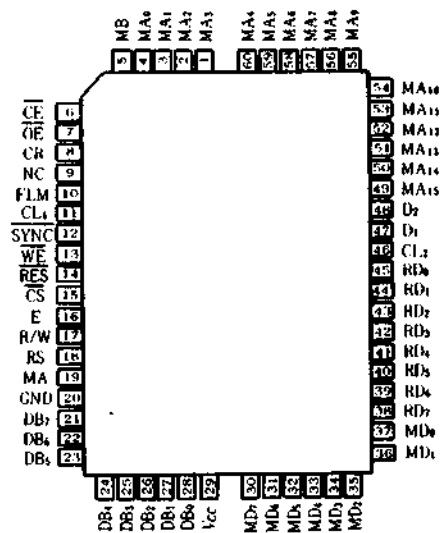

(Top View)

HD 61830

■ BLOCK DIAGRAM

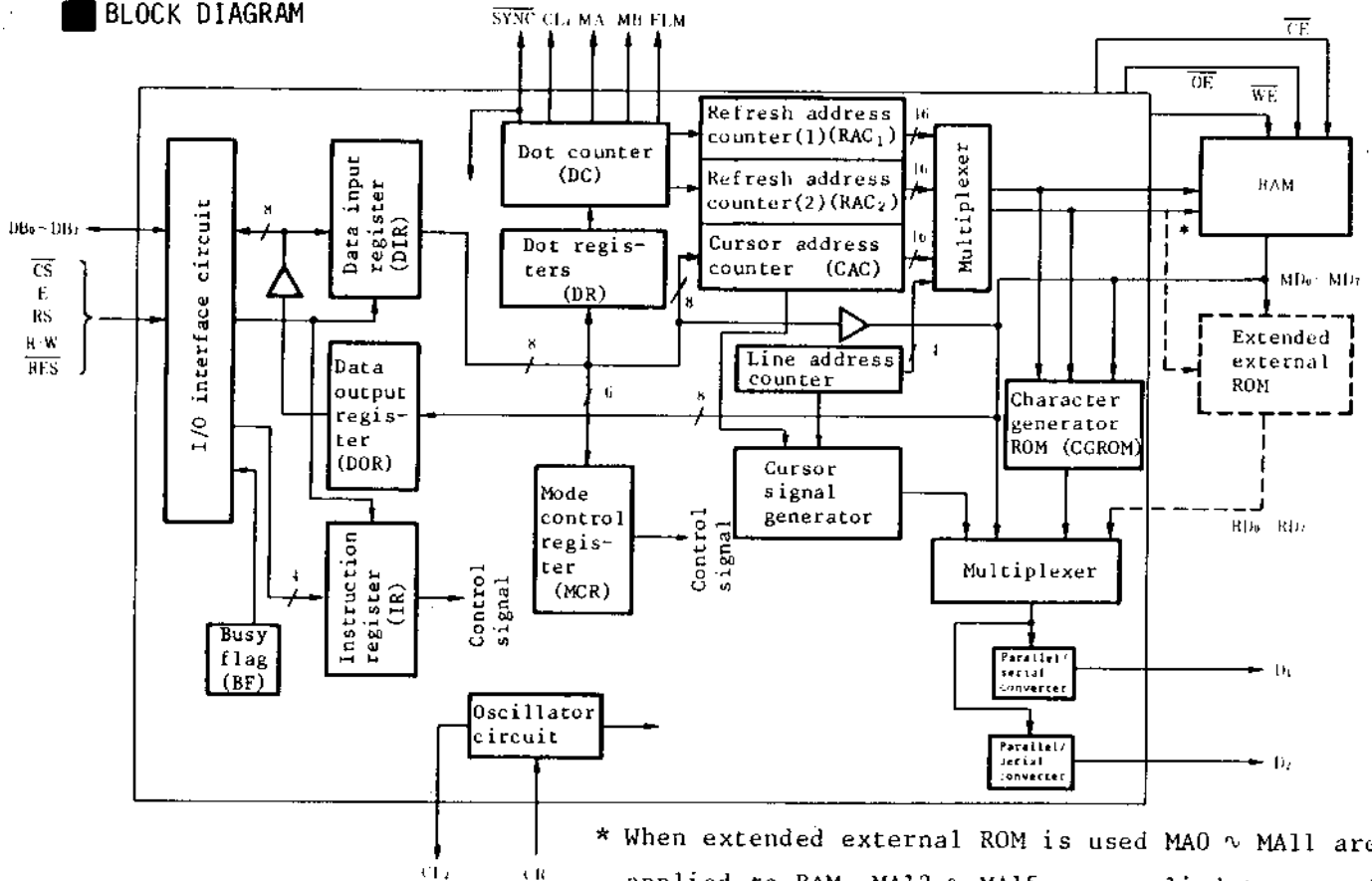

■ FEATURES

- Dot matrix liquid crystal graphic display controller
- Display control capacity
 - Graphic mode 512K dots (2¹⁶ bytes)
 - Character mode 4096 characters (2¹² characters)
- Internal character generator ROM 7360 bits
 - 160 types of 5×7 dot character fonts
 - 32 types of 5×11 dot character fonts Total 192 types
 - (Can be extended to 256 types (4K bytes max.) by external ROM)
- Interfaceable to 8-bit MPU
- Display duty (Can be selected by a program)
 - Static to 1/128 duty selectable
- Various instruction functions
 - Scroll, Cursor ON/OFF/blink, Character blink, Bit manipulation
- Display method Selectable A or B types
- Operating frequency 2.4MHz
- Low power dissipation
- Power supply: Single +5V

■ BLOCK FUNCTIONS

● Registers

The HD61830B has the five types of registers: instruction register (IR), data input register (DIR), data output register (DOR), dot registers (DR) and mode control register (MCR).

The IR is a 4-bit register which stores the instruction codes for specifying MCR, DR, a start address register, a cursor address register and so on. The lower order 4 bits DB0 to DB3 of data buses are written in it.

The DIR is an 8-bit register used to temporarily store the data written into the external RAM, DR, MCR and so on.

The DOR is an 8-bit register used to temporarily store the data read from the external RAM. Cursor address information is written into the cursor address counter (CAC) through the DIR. When the memory read instruction is set in the IR (latched at the falling edge of E signal), the data of external RAM is read to DOR by an internal operation. The data is transferred to the MPU by reading the DOR with the next instruction (the contents of DOR are output to the data bus when E is at "High" level).

The DR are registers used to store the dot informations such as character pitches and the number of vertical dots and so on. The information sent from the MPU is written into the DR via the DIR.

The MCR is a 6-bit register used to store the data which specifies states of display such as display ON/OFF and cursor ON/OFF/blink etc. The information sent from the MPU is written in it via the DIR.

● Busy Flag (BF)

With "1", the busy flag indicates the HD61830B is performing an internal operation. The next instruction cannot be accepted. As shown in Control Instruction (14), the busy flag is output on DB7 under the conditions of RS=1, R/W=1 and E=1. Make sure the busy flag is "0" before writing the next instruction.

● Dot Counters (DC)

The dot counters are counters that generate liquid crystal display timing according to the contents of DR.

● Refresh Address Counters (RAC1/RAC2)

The refresh address counters are counters used to control the addresses of external RAM, character generator ROM (CGROM) and extended external ROM having the two types: RAC1 and RAC2. The RAC1 is used for upper half of screen and the RAC2 for lower half. In the graphic mode, 16-bit data is output and used as the address signal of external RAM. In the character mode, the high order 4 bits (MA12 ~ MA15) are ignored. The 4 bits of line address counter are output instead of it and used as the address of extended ROM.

● Character Generator ROM

The character generator ROM has 7360 bits in total and stores 192 types of character data. A character code (8 bits) from the external RAM and a line code (4 bits) from the line address counter are applied to its address signals, and it outputs 5-bit dot data.

The character font is 5×7 (160 types) or 5×11 (32 types). The use of extended ROM allows 8×16 (256 types max.) to be used.

● Cursor Address Counter

The cursor address counter is a 16-bit counter that can be preset by the instruction. It is used to hold an address when the data of external RAM is read or written (when display dot data or a character code is read or written). The value of cursor address counter is automatically increased by 1 after the display data is read or written and after the Set/Clear Bit instruction is executed.

● Cursor Signal Generator

The cursor can be displayed by the instruction in the character mode. The cursor is automatically generated on the display specified by the cursor address and cursor position.

● Parallel/Serial Conversion

The parallel data sent from the external RAM, character generator ROM or extended ROM is converted into serial data by two parallel/serial conversion circuits and transferred to the liquid crystal driver circuits for upper screen and lower screen simultaneously.

HD 61830

■ TERMINAL FUNCTIONS

Name	Function
DB0~7	Data bus ... Three-state I/O common terminal Data is transferred to MPU through DB0 to DB7.
\overline{CS}	Chip select ... Selected state with $\overline{CS}=0$.
R/W	Read/Write ... R/W=1 ... MPU ← HD61830B R/W=0 ... MPU → HD61830B
RS	Register select ... RS=1 ... Instruction register RS=0 ... Data register
E	Enable ... Data is written at the fall of E. Data can be read while E is 1.
CR	External clock input.
\overline{RES}	Reset ... $\overline{RES}=0$ results in display OFF, slave mode and Hp=6.
MA0~15	External RAM address output In character mode, the line code for external CG is output through MA12 to MA15 ("0": Character 1st line, "F": Character 16th line).
MD0~7	Display data bus ... Three-state I/O common terminal.
RD0~7	ROM data input ... Dot data from external character generator is input.
\overline{WE}	Write enable ... Write signal for external RAM.
CL2	Display data shift clock for LCD drivers.
CL1	Display data latch signal for LCD drivers.
FLM	Frame signal for display synchronization.
MA	Signal for converting liquid crystal driving signal into AC, A type.
MB	Signal for converting liquid crystal driving signal into AC, B type.
D1, D2	Display data serial output D1 ... For upper half of screen D2 ... For lower half of screen
\overline{SYNC}	Synchronous signal for parallel operation. Three-state I/O common terminal (with pull-up MOS). Master ... Synchronous signal is output. Slave Synchronous signal is input.

Name	Function
\overline{CE}	Chip enable $\overline{CE}=0$... Chip enable make external RAM in active.
\overline{OE}	Output enable $\overline{OE}=1$... Output enable informs external RAM that HD61830B requires data bus.
NC	Unused terminal. Don't connect any wires to this terminal.

■ ABSOLUTE MAXIMUM RATINGS

Item	Symbol	Value	Unit	Note
Supply voltage	VCC	-0.3 ~ +7.0	V	1
Terminal voltage	V _T	-0.3 ~ VCC+0.3	V	1
Operating temperature	T _{opr}	-20 ~ +75	°C	
Storage temperature	T _{stg}	-55 ~ +125	°C	

Note 1: All voltage is referred to GND=0.V

Note 2: If LSI's are used beyond absolute maximum ratings, they may be permanently destroyed. We strongly recommend you to use the LSI's within electrical characteristic limits for normal operation, because use beyond these conditions will cause malfunction and poor reliability.

HD 61830

■ ELECTRICAL CHARACTERISTICS

($V_{CC}=5V\pm 10\%$, $GND=0V$, $T_a=-20\sim+75^\circ C$)

Item	Symbol	Test condition	Min.	Typ.	Max.	Unit	Note
Input "High" voltage (TTL)	V_{IH}		2.2	-	V_{CC}	V	2
Input "Low" voltage (TTL)	V_{IL}		0	-	0.8	V	3
Input "High" voltage	V_{IHR}		3.0	-	V_{CC}	V	4
Input "High" voltage (CMOS)	V_{IHC}		$0.7V_{CC}$	-	V_{CC}	V	5
Input "Low" voltage (CMOS)	V_{ILC}		0	-	$0.3V_{CC}$	V	5
Output "High" voltage (TTL)	V_{OH}	$-I_{OH}=0.6mA$	$V_{CC}-0.4$	-	V_{CC}	V	6
Output "Low" voltage (TTL)	V_{OL}	$I_{OL}=1.6mA$	0	-	0.4	V	6
Output "High" voltage (CMOS)	V_{OHC}	$-I_{OH}=0.6mA$	$V_{CC}-0.4$	-	V_{CC}	V	7
Output "Low" voltage (CMOS)	V_{OLC}	$I_{OL}=0.6mA$	0	-	0.4	V	7
Input leakage current	I_{IN}	$V_{IN}=0\sim V_{CC}$	-5	-	5	μA	8
Output leakage current	I_{OUT}	$V_{OUT}=0\sim V_{CC}$	-10	-	10	μA	9
Pull-up current	I_{PL}	$V_{in}=GND$	2	10	20	μA	11
Power dissipation	P_w	External clock $f_{cp}=2.4MHz$	-	-	50	mW	10

Note 2: Applied to input terminals and I/O common terminals, except terminals \overline{SYNC} , CR and \overline{RES} .

Note 3: Applied to input terminals and I/O common terminals, except terminals \overline{SYNC} and CR.

Note 4: Applied to terminal \overline{RES} .

Note 5: Applied to terminals \overline{SYNC} and CR.

Note 6: Applied to terminals $DB0\sim DB7$, \overline{WE} , $MA0\sim MA15$, \overline{OE} , \overline{CE} , and $MD0\sim MD7$.

Note 7: Applied to terminals \overline{SYNC} , FLM, CL1, CL2, D1, D2, MA and MB.

Note 8: Applied to input terminals.

Note 9: Applied to I/O common terminals. However, the current which flows into the output drive MOS is excluded.

Note 10: The current which flows into the input and output circuits is excluded. When the input of CMOS is in the intermediate level, current flows through the input circuit, resulting in the increase of power supply current. To avoid this, input must be fixed at high or low.

Note 11: Applied to \overline{SYNC} , $DB0\sim DB7$, and $RD0\sim RD7$.

● Shape of Input Terminal

Applicable terminal: \overline{CS} , E, RS, R/W, \overline{RES} , CR (Without pull-up MOS)

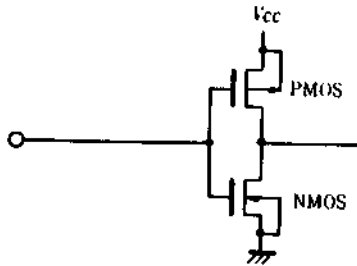

Applicable terminal: RD0~RD7 (With pull-up MOS)

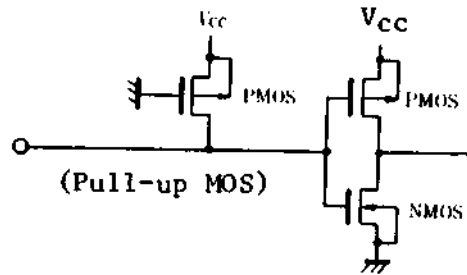

● Shape of Output Terminal

Applicable terminal: CL1, CL2, MA, MB, FLM, D1, D2, \overline{WE} , \overline{OE} , \overline{CE} , MA0~MA15

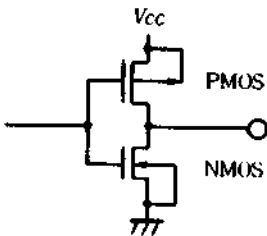

● Shape of I/O Common Terminal

Applicable terminal: DB0~DB7, \overline{SYNC} , MD0~MD7 (MD0~MD7 have no pull-up MOS)

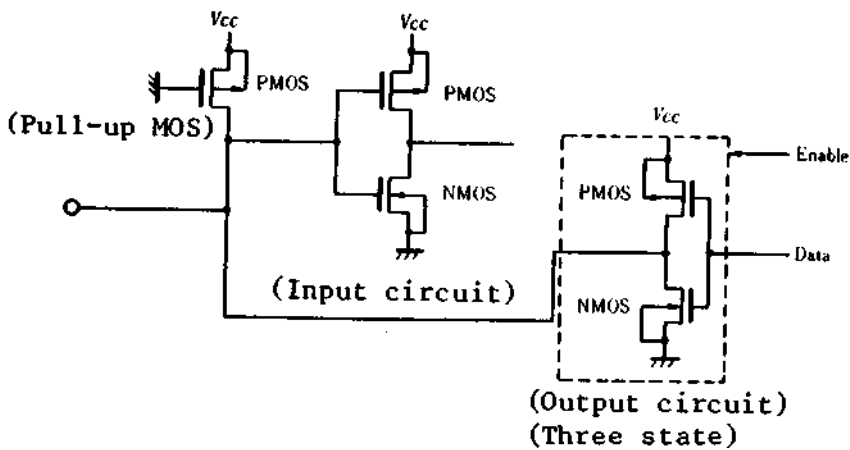

HD 61830

● Clock Operation

Item	Symbol	Test condition	Min.	Typ.	Max.	Unit	Note
External clock operating frequency	f_{cp}		100	-	2400	kHz	1
External clock duty	Duty		47.5	50	52.5	%	1
External clock rise time	t_{rcp}		-	-	25.0	ns	1
External clock fall time	t_{fcp}		-	-	25.0	ns	1
$\overline{\text{SYNC}}$ output hold time	t_{HSYO}		30	-	-	ns	2, 3
$\overline{\text{SYNC}}$ output delay time	t_{DSY}		-	-	210	ns	2, 3
$\overline{\text{SYNC}}$ input hold time	t_{HSYI}		10	-	-	ns	2
$\overline{\text{SYNC}}$ input set-up time	t_{SSY}		-	-	180	ns	2

Note 1: Applied to external clock input terminal.

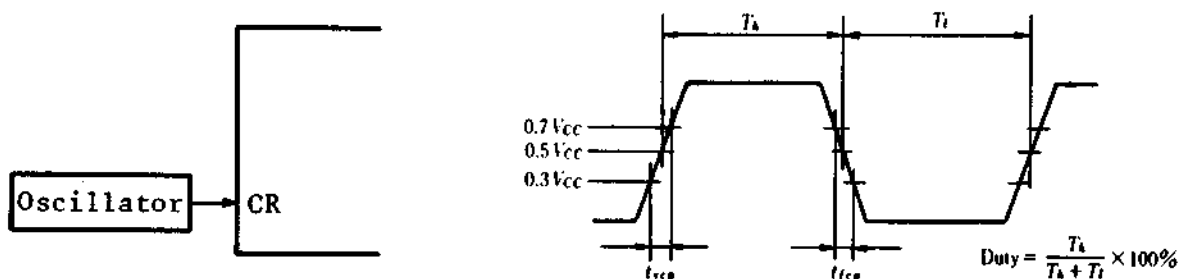

Note 2: Applied to $\overline{\text{SYNC}}$ terminal.

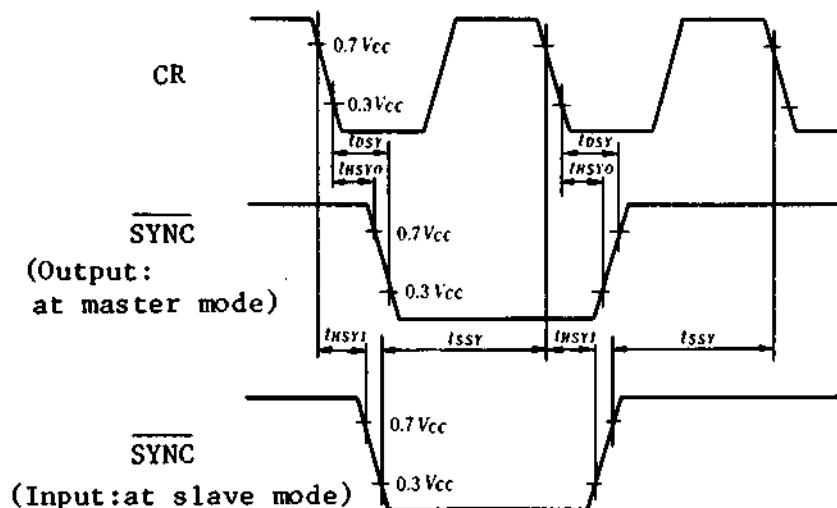

Note 3: Testing load circuit.

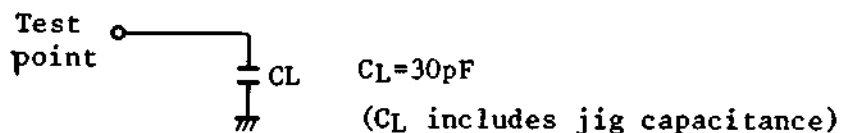

● Bus Read/Write Operation (Interface to MPU)

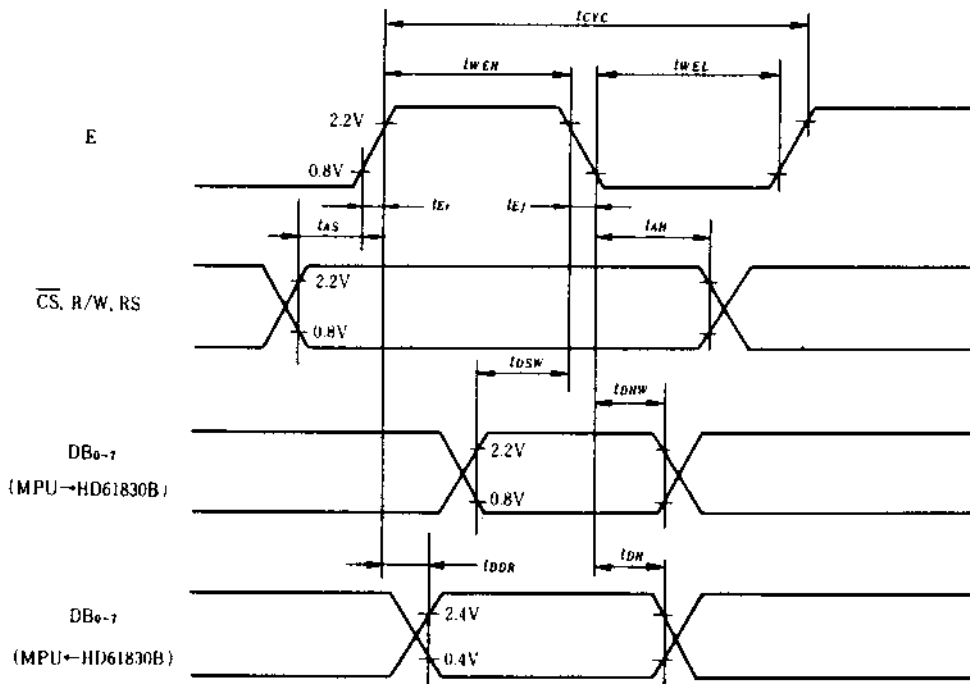

Item	Symbol	Min.	Typ.	Max.	Unit
Enable cycle time	t_{CYC}	1.0	-	-	μs
Enable pulse width	"High" level	t_{WEH}	0.45	-	μs
	"Low" level	t_{WEL}	0.45	-	μs
Enable rise time	t_{Er}	-	-	25	ns
Enable fall time	t_{Ef}	-	-	25	ns
Setup time	t_{AS}	140	-	-	ns
Data setup time	t_{DSW}	225	-	-	ns
Data delay time	t_{DDR}	-	-	225	ns(Note)
Data hold time	t_{DHW}	10	-	-	ns
Address hold time	t_{AH}	10	-	-	ns
Data hold time	t_{DH}	20	-	-	ns

Note: The following load circuit is connected for specification:

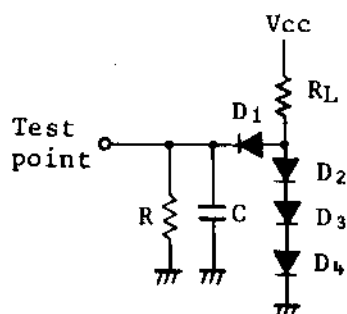

$$R_L = 2.4k\Omega$$

$$R = 11k\Omega$$

$$C = 130 \text{ pF (C includes jig capacitance)}$$

$$\text{Diodes D1 to D4: 1S2074 (H)}$$

HD 61830

● Interface to External RAM and ROM

Item	Symbol	Test condition	Min.	Typ.	Max.	unit	Note
MA0~MA15 delay time	t_{DMA}		-	-	300	ns	1, 2, 3
MA0~MA15 hold time	t_{HMA}		40	-	-	ns	1, 2, 3
\overline{CE} delay time	t_{DCE}		-	-	300	ns	1, 2, 3
\overline{CE} hold time	t_{HCE}		40	-	-	ns	1, 2, 3
\overline{OE} delay time	t_{DOE}		-	-	300	ns	1, 3
\overline{OE} hold time	t_{HOE}		40	-	-	ns	1, 3
MD output delay time	t_{DMD}		-	-	150	ns	1, 3
MD output hold time	t_{HMDW}		10	-	-	ns	1, 3
\overline{WE} delay time	t_{DWE}		-	-	150	ns	1, 3
\overline{WE} clock pules width	t_{WWE}		150	-	-	ns	1, 3
MD output high impedance time (1)	t_{ZMDF}		10	-	-	ns	1, 3
MD output high impedance time (2)	t_{ZMDR}		50	-	-	ns	1, 3
RD data set-up time	t_{SRD}		50	-	-	ns	2
RD data hold time	t_{HRD}		40	-	-	ns	2
MD data set-up time	t_{SMD}		50	-	-	ns	2
MD data hold time	t_{HMD}		40	-	-	ns	2

Note 1: RAM write timing

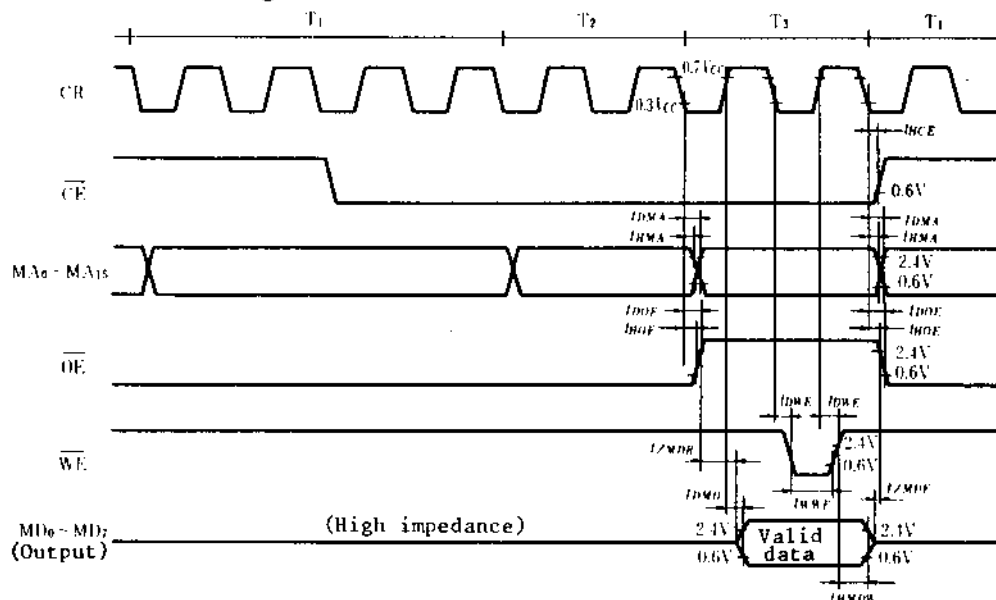

T1: Memory data refresh timing for upper screen

T2: Memory data refresh timing for lower screen

T3: Memory read/write timing

Note 2: ROM/RAM read timing

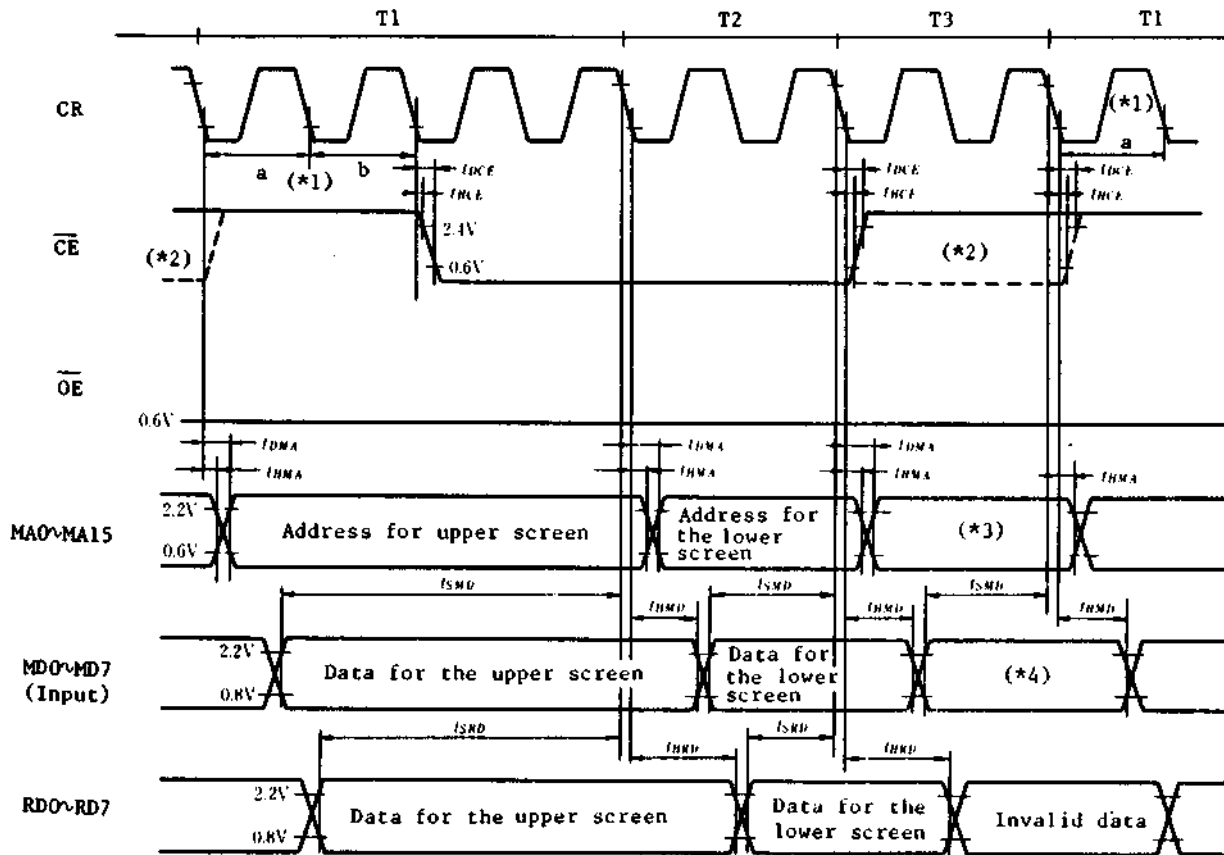

- (*1) This figure shows the timing in the case of $H_p=8$.
In the case of $H_p=7$, time shown by "b" becomes zero., and
in the case of $H_p=6$, time shown by "a" and "b" becomes zero.
Therefore, the number of clock pulse during T1 become 4, 3 or 2
in the case of $H_p=8$, $H_p=7$ or $H_p=6$ respectively.
- (*2) The waveform in the case of instruction with memory read is shown
with a dash line. In other case, the waveform shown with a solid
line is generated.
- (*3) When the instruction with RAM read/write is excuted, the value of
cursor address is output. In other case, invalid data is output.
- (*4) When the instruction with RAM read is excuted, HD61830B latch the
data at this timing. In other case, this data is invalid.

HD 61830

Note 3: Test load circuit

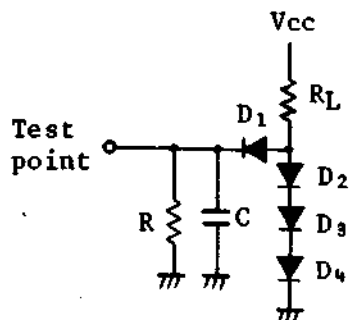

$R_L = 2.4k\Omega$

$R = 11k\Omega$

$C = 50 \text{ pF}$ (C includes jig capacitance)

Diodes D1 to D4: 1S2074 (H)

● Data Transfer to Driver LSI

Items	Symbol	Test condition	Min.	Typ.	Max	Unit	Note
Clock cycle time	t_{WCL2}		416	-	-	ns	1, 3
Clock pulse width (High level)	t_{WCH}		150	-	-	ns	1, 3
Clock pulse width (Low level)	t_{WCL}		150	-	-	ns	1, 3
Data delay time	t_{DD}		-	-	50	ns	1, 3
Data hold time	t_{DH}		100	-	-	ns	1, 3
Clock phase difference (1)	t_{CL1}		100	-	-	ns	1, 3
Clock phase difference (2)	t_{CL2}		100	-	-	ns	1, 3
Clock phase difference (3)	t_{CL3}		100	-	-	ns	1, 3
MA, MB delay time	t_{DM}		-200	-	200	ns	1, 3
FLM set-up time	t_{SF}		400	-	-	ns	2, 3
FLM hold time	t_{HF}		1000	-	-	ns	2, 3
MA set-up time	t_{SMA}		400	-	-	ns	2, 3
MA hold time	t_{HMA}		1000	-	-	ns	2, 3

HD 61830

Note 1:

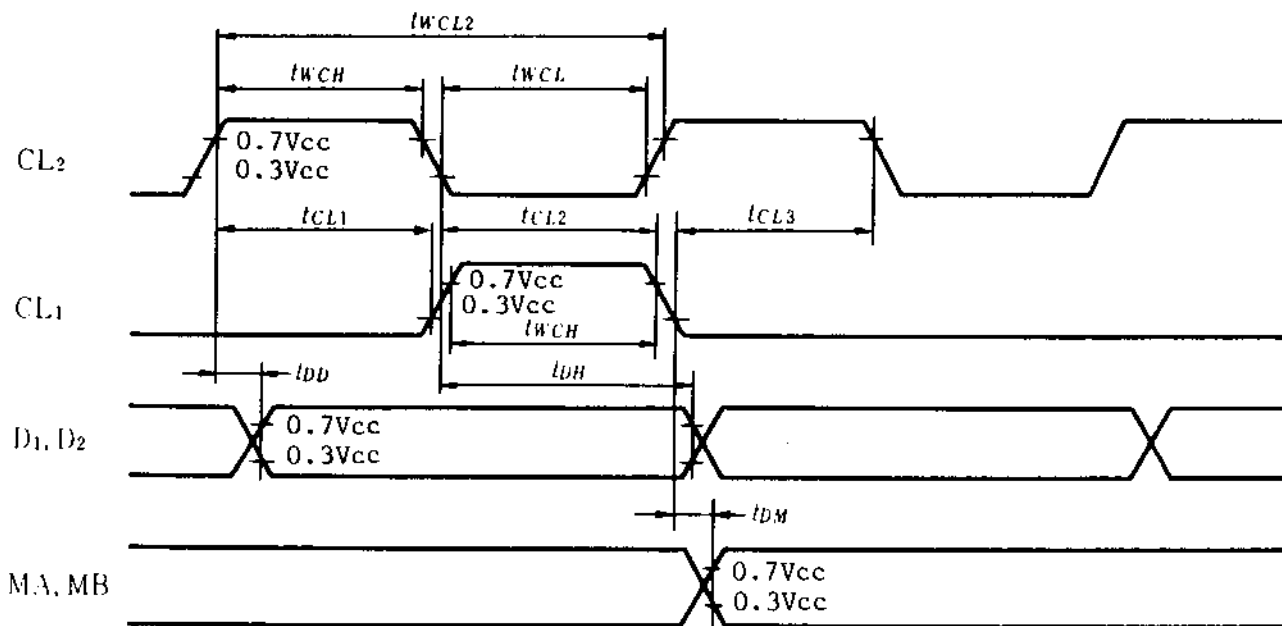

Note 2:

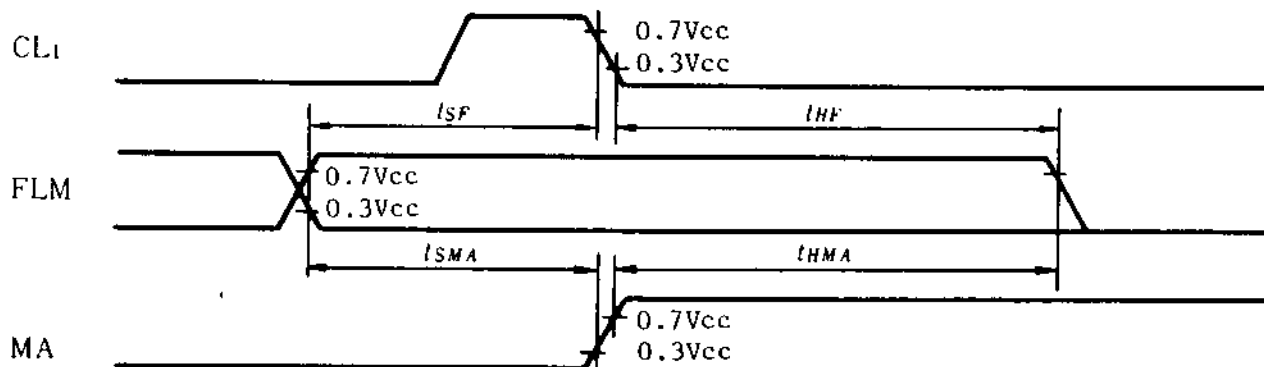

Note 3: Test load circuit

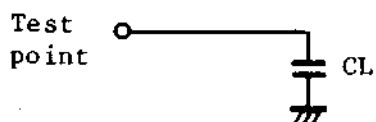

$CL=100\text{pF}$ (C_L includes jig) capacitance

HD 61830

● Display Control Instructions

Display is controlled by writing data into the instruction register and 13 data registers. The RS signal distinguishes the instruction register from the data registers. 8-bit data is written into the instruction register with RS=1, and the code of data register is specified. After that, the 8-bit data is written in the data register and the specified instruction is executed with RS=0.

During the execution of the instruction, no new instruction can be accepted. Since the busy flag is set during this, read the busy flag and make sure it is 0 before writing the next instruction.

(1) Mode control

Code "\$00" (hexadecimal) written into the instruction register specifies the mode control register.

Register	R/W	RS	DB7	DB6	DB5	DB4	DB3	DB2	DB1	DB0
Instruction reg.	0	1	0	0	0	0	0	0	0	0
Mode control reg.	0	0	0	0	Mode data					

DB5	DB4	DB3	DB2	DB1	DB0	Cursor/blink	CG	Graphic/character display		
1/0	1/0	0	0	0	0	Cursor OFF	Internal CG	Character display (Character mode)*		
		0	1			Cursor ON				
		1	0			Cursor OFF, character blink				
		1	1			Cursor blink				
		0	0		1	Cursor OFF	External CG			
		0	1			Cursor ON				
		1	0			Cursor OFF, character blink				
		1	1			Cursor blink				
		0	0		1	0				Graphic mode
		Display ON/OFF	Master/slave		Blink	Cursor	Graphic/character mode		Ext./Int. CG	

1: Master mode
0: Slave mode

1: Display ON
0: Display OFF

*Character mode: Der Controller HD61830B kann hier nur 4kB des Display-RAM's verwalten; dh. Lötbrücken auf 4kB setzen! Oder alle ASCII's doppelt setzen (z.B. auf 0003h und 1003h).

(2) Set character pitch

Register	R/W	RS	DB7	DB6	DB5	DB4	DB3	DB2	DB1	DB0
Instruction reg.	0	1	0	0	0	0	0	0	0	1
Character pitch reg.	0	0	(V _p -1) binary				0	(H _p -1) binary		

V_p indicates the number of vertical dots per character. The space between the vertically-displayed characters is considered for determination.

This value is meaningful only during character display (in the character mode) and becomes invalid in the graphic mode.

The H_p indicates the number of horizontal dots per character in display, including the space between horizontally-displayed characters. In the graphic mode, the H_p indicates the number of bits of 1-byte display data to be displayed.

There are three H_p values.

H _p	DB2	DB1	DB0	
6	1	0	1	Horizontal character pitch 6
7	1	1	0	Horizontal character pitch 7
8	1	1	1	Horizontal character pitch 8

(3) Set number of characters

Register	R/W	RS	DB7	DB6	DB5	DB4	DB3	DB2	DB1	DB0
Instruction reg.	0	1	0	0	0	0	0	0	1	0
Number-of-characters reg.	0	0	0	(H _N - 1) binary						

H_N indicates the number of horizontal characters in the character mode or the number of horizontal bytes in the graphic mode. If the total sum of horizontal dots on the screen is taken as n,

$$n = H_p \times H_N$$

H_N can be set with an even number of 2 to 128 (decimal).

HD 61830

(4) Set number of time division (inverse of display duty ratio)

Register	R/W	RS	DB7	DB6	DB5	DB4	DB3	DB2	DB1	DB0
Instruction reg.	0	1	0	0	0	0	0	0	1	1
Number-of-time shares reg.	0	0	0	(Nx - 1) binary						

Nx indicates the number of time division in multiplex display.

1/Nx is a display duty ratio.

A value of 1 to 128 (decimal) can be set to Nx.

(5) Set cursor position

Register	R/W	RS	DB7	DB6	DB5	DB4	DB3	DB2	DB1	DB0
Instruction reg.	0	1	0	0	0	0	0	1	0	0
Cursor position reg.	0	0	0	0	0	0	(Cp - 1) binary			

Cp indicates the position in a character where the cursor is displayed in the character mode. For example, in 5×7 dot font, the cursor is displayed under a character by specifying Cp=8 (decimal). The cursor horizontal length is equal to the horizontal character pitch Hp. A value of 1 to 16 (decimal) can be set to Cp. If a smaller value than the number of vertical character pitches Vp is set (Cp≤Vp), and a character is overlapped with the cursor, the cursor has higher priority of display (at cursor display ON). If Cp is greater than Vp, no cursor is displayed. The cursor horizontal length is equal to Hp.

(6) Set display start low order address

Register	R/W	RS	DB7	DB6	DB5	DB4	DB3	DB2	DB1	DB0
Instruction reg.	0	1	0	0	0	0	1	0	0	0
Display start address reg. (low order byte)	0	0	(Start low order address) binary							

(7) Set display start high order address

Register	R/W	RS	DB7	DB6	DB5	DB4	DB3	DB2	DB1	DB0
Instruction reg.	0	1	0	0	0	0	1	0	0	1
Display start address reg. (high order byte)	0	0	(Start high order address) binary							

These instructions cause display start addresses to be written in the display start address registers. The display start address indicates a RAM address at which the data displayed at the top left end on the screen is stored. In the graphic mode, the start address is composed of high/low order 16 bits. In the character display, it is composed of the lower 4 bits of high order address (DB₃ ~ DB₀) and 8 bits of low order address. The upper 4 bits of high order address are ignored.

(8) Set cursor address (low order) (RAM write low order address)

Register	R/W	RS	DB7	DB6	DB5	DB4	DB3	DB2	DB1	DB0
Instruction reg.	0	1	0	0	0	0	1	0	1	0
Cursor address counter (low order byte)	0	0	(Cursor low order address) binary							

(9) Set cursor address (high order) (RAM write high order address)

Register	R/W	RS	DB7	DB6	DB5	DB4	DB3	DB2	DB1	DB0
Instruction reg.	0	1	0	0	0	0	1	0	1	1
Cursor address counter (high order byte)	0	0	(Cursor high order address) binary							

These instructions cause cursor addresses to be written in the cursor address counters. The cursor address indicates an address for sending or receiving display data and character codes to or from the RAM. Namely, data at address specified by the cursor address are read/written. In the character mode, the cursor is displayed at the digit specified by the cursor address.

A cursor address consists of the low-order address (8 bits) and the high-order address (8 bits). Satisfy the following requirements.

When setting the cursor address.

1.	When you want to rewrite (set) both the low order address and the high order address.	Set the low order address and then set the high order address.
2.	When you want to rewrite only the low order address.	Don't fail to set the high order address again after setting the low order address.
3.	When you want to rewrite only the high order address.	Set the high order address. You don't have to set the low order address again.

HD 61830

The cursor address counter is a 16 bit up-counter with SET and RESET functions. When the bit N changes from 1 to 0, the bit N+1 is added by 1. When setting the low order address, the LSB (bit 1) of the high order address is added by 1 if the MSB (bit 8) of the low order address changes from 1 to 0. Therefore, set both the low order address and the high order address as shown in above table.

(10) Write display data

Register	R/W	RS	DB7	DB6	DB5	DB4	DB3	DB2	DB1	DB0
Instruction reg.	0	1	0	0	0	0	1	1	0	0
RAM	0	0	MSB (pattern data, character code) LSB							

After the code '\$'OC' is written into the instruction register with RS=1, 8 bit data with RS=0 should be written into the data register. This data is transferred to the RAM specified by the cursor address as display data or character code. The cursor address is increased by 1 after this operation.

(11) Read display data

Register	R/W	RS	DB7	DB6	DB5	DB4	DB3	DB2	DB1	DB0
Instruction reg.	0	1	0	0	0	0	1	1	0	1
RAM	1	0	MSB (pattern data, character code) LSB							

Data can be read from the RAM with RS=0 after writing code '\$'OD" into the instruction register. The read procedure is as follows:

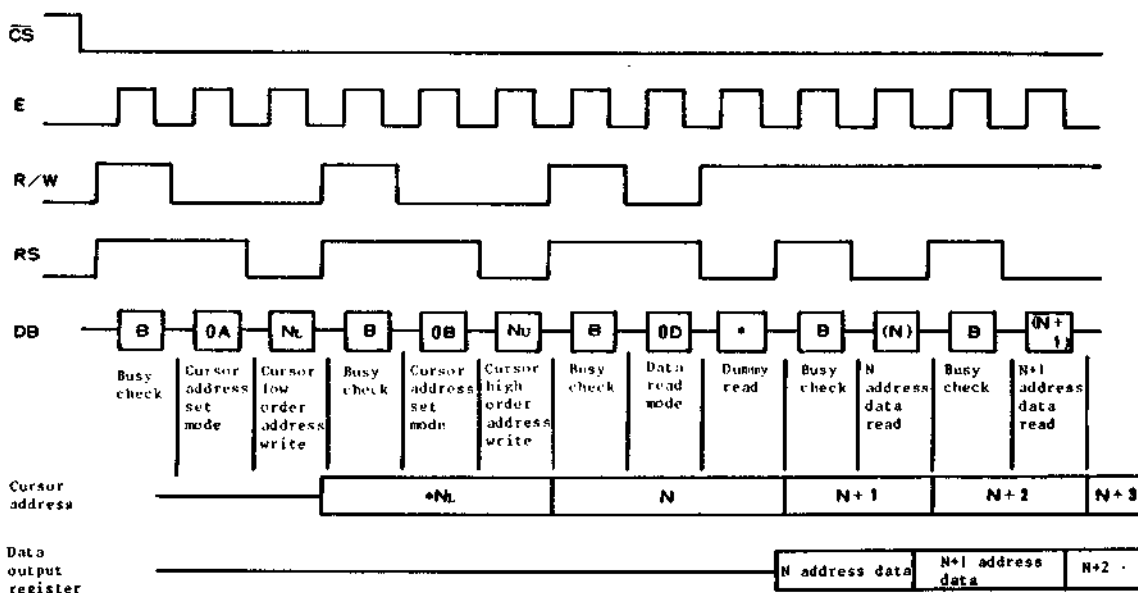

This instruction outputs the contents of data output register on Data Bus (DB0 to DB7) and then transfers RAM data specified by a cursor address to the data output register, also increasing the cursor address by 1. After setting the cursor address, correct data is not output at the first read but at the second time. Thus, make one dummy read when reading data after setting the cursor address.

(12) Clear bit

Register	R/W	RS	DB7	DB6	DB5	DB4	DB3	DB2	DB1	DB0
Instruction reg.	0	1	0	0	0	0	1	1	1	0
Bit clear reg.	0	0	0	0	0	0	0	(N_B-1) binary		

(13) Set bit

Register	R/W	RS	DB7	DB6	DB5	DB4	DB3	DB2	DB1	DB0
Instruction reg.	0	1	0	0	0	0	1	1	1	1
Bit set reg.	0	0	0	0	0	0	0	(N_B-1) binary		

The Clear/Set Bit instruction sets 1 bit in a byte of display data RAM to 0 or 1, respectively. The position of the bit in a byte is specified by N_B and RAM address is specified by cursor address. After the execution of the instruction, the cursor address is automatically increased by 1. N_B is a value of 1 to 8. $N_B=1$ and $N_B=8$ indicates LSB and MSB, respectively.

(14) Read busy flag

Register	R/W	RS	DB7	DB6	DB5	DB4	DB3	DB2	DB1	DB0
Busy flag	1	1	1/0	*						

When the read mode is set with $RS=1$, the busy flag is output to DB7. The busy flag is set to 1 during the execution of any of instructions (1) to (13). After the execution, it is set to 0. The next instruction can be accepted. No instruction can be accepted when busy flag=1. Before executing an instruction or writing data, perform a busy flag check to make sure the busy flag is 0. When data is written in the register ($RS=1$), busy flag doesn't change. Thus, no busy flag check is required just after the write operation into the instruction register with $RS=1$.

The busy flag can be read without specifying any instruction register.

HD 61830

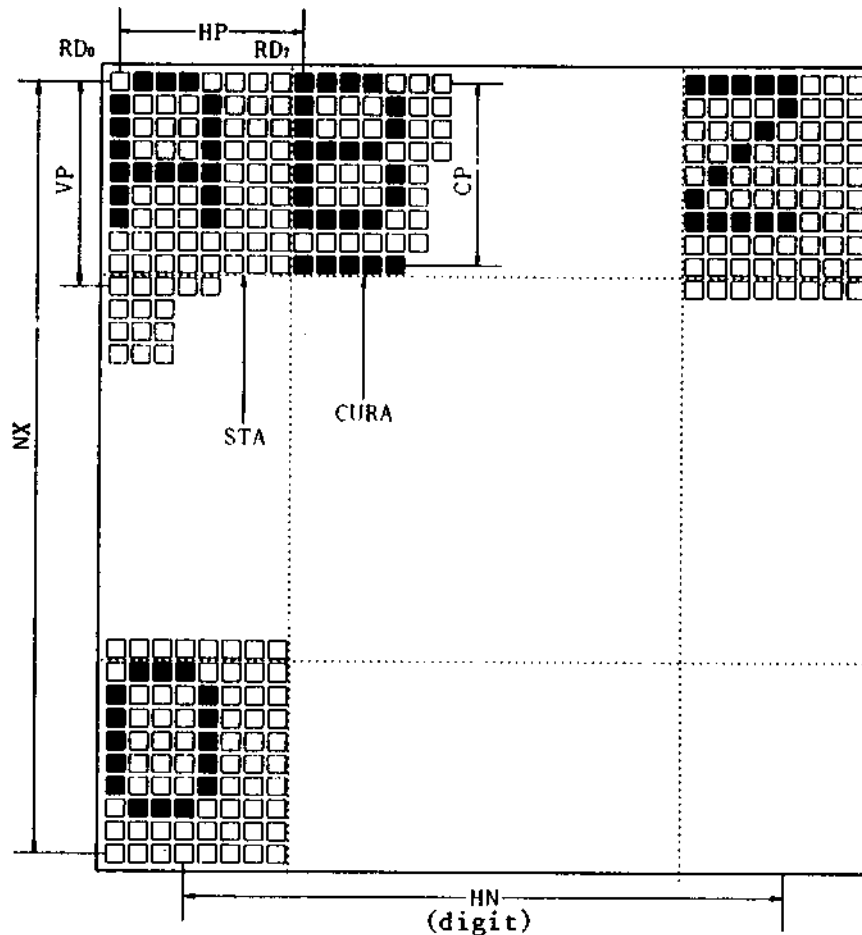

Symbol	Name	Meaning	Value
H _p	Horizontal character Pitch	Lateral character pitch	6 to 8 dots
H _N	Number of horizontal characters	Number of lateral characters per line (number of digits) in the character mode or number of bytes per line in the graphic mode.	2 to 128 digits (an even number)
V _p	Vertical character pitch	Longitudinal character pitch	1 to 16 dots
C _p	Cursor position	Line number on which the cursor can be displayed	1 to 16 lines
N _x	Number of time division	Inverse of display duty ratio	1 to 128 lines

Note: if the number of vertical dots on screen is taken as m, and the number of horizontal dots as n,

$$1/m = 1/N_x = \text{display duty ratio}$$

$$n = H_p \times H_N, m/V_p = \text{Number of display lines}$$

$$C_p \leq V_p$$

● Display Mode

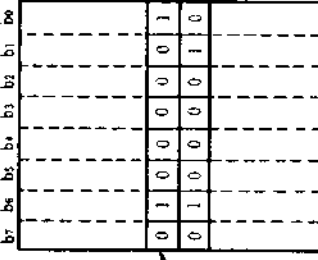
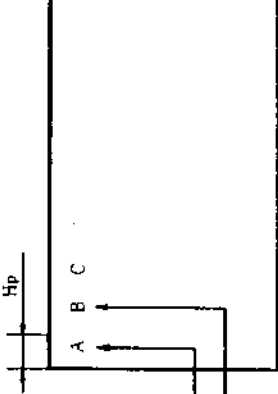
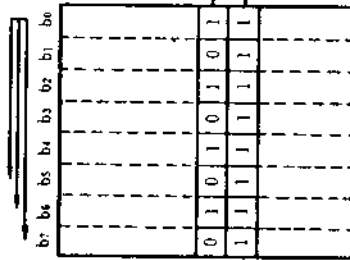
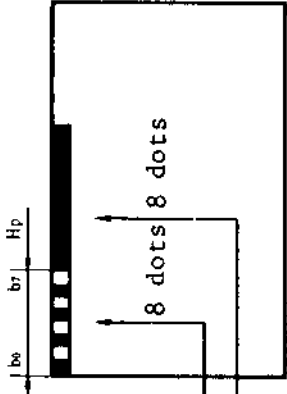
Display mode	Display data from MPU	RAM	Liquid crystal display panel
<p>Character display</p>	<p>Character code (8 bits)</p>	 <p>Start address</p>	 <p>Hp: 6, 7 or 8 dots</p>
<p>Graphic</p>	<p>Display pattern (8 bits)</p>	 <p>Start address</p>	 <p>Hp: 8 dots</p>

HD 61830

APPLICATION (CHARACTER MODE, EXTERNAL CG, CHARACTER FONT 8X8)

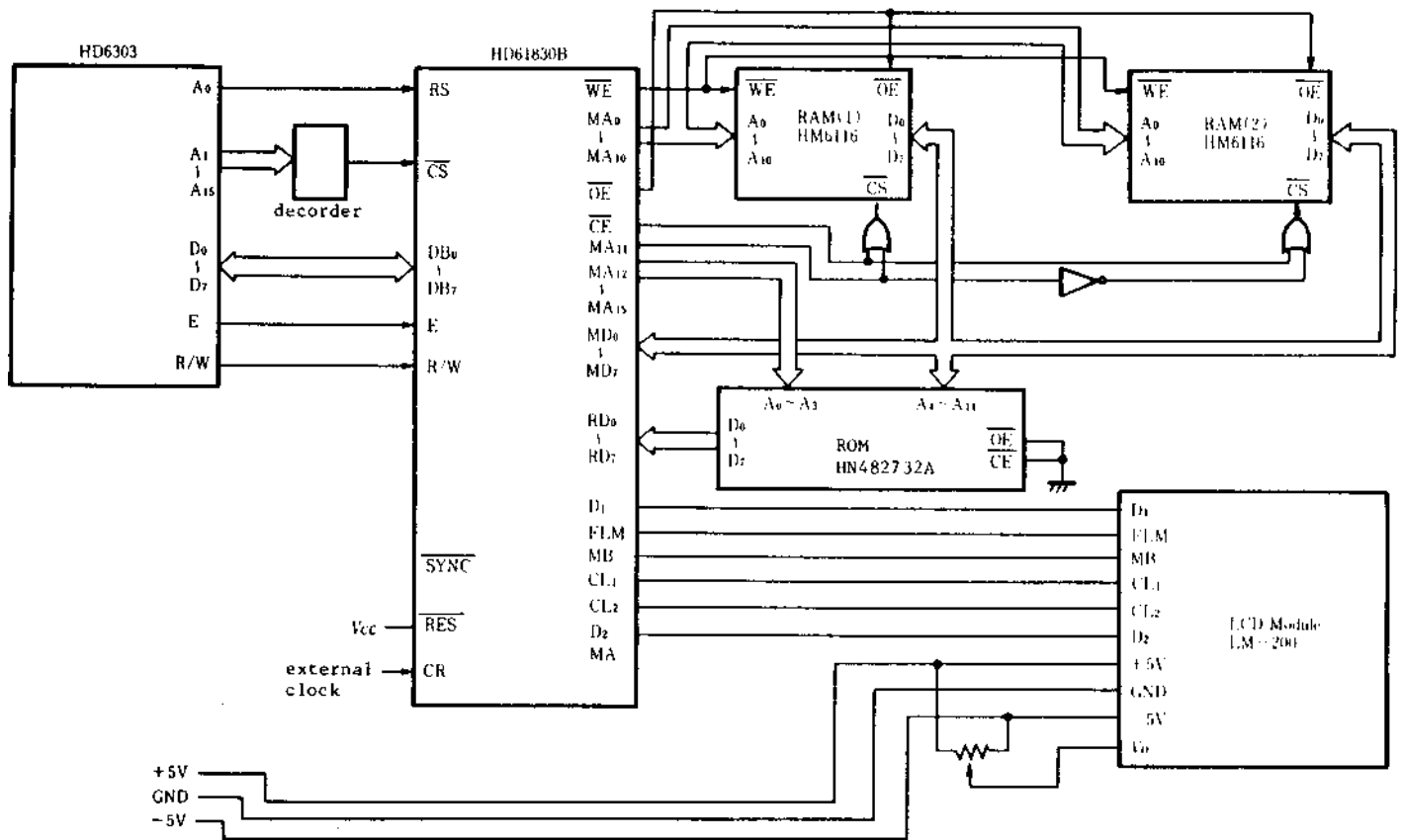

APPLICATION (GRAPHIC MODE)

