

GT9271

10-Point Capacitive Touch Controller for MID

Rev.04——Nov.11, 2014

===== Disclaimer =====

The information concerning the device in this publication is intended for you only and is subject to change without prior notice. It is your responsibility to ensure its application complies with technical specifications. Shenzhen Huiding Technology Co., Ltd. (hereafter referred to as "GOODIX") makes no representation or guarantee for this information, either expressed or implied, written or verbal, statutory or otherwise including but not limited to representation or guarantee for its application, quality, performance, merchantability or fitness for a particular purpose. GOODIX shall assume no responsibility for this information and relevant consequences arising out of the use of such information. Without written consent of GOODIX, it is prohibited to use GOODIX products as critical components in any life support system. This document conveys no licenses, implicitly or otherwise, to any intellectual property rights belonging to GOODIX.

Contents

1. Overview.....	4
2. Features.....	4
3. Block Diagram.....	5
4. Pin Configurations.....	6
5. Sensor Design.....	7
5.1 Layout of Rx Channels.....	7
5.2 Layout of Tx Channels.....	7
5.3 Sensor Design Specifications.....	8
5.4 Touch Key Design.....	8
6. I ² C Communication.....	9
6.1 I ² C Timing.....	9
a) Data Transmission.....	11
b) Writing Data to GT9271.....	11
c) Reading Data from GT9271.....	12
7. HotKnot.....	13
7.1 Start HotKnot.....	13
7.2 Data Transmission between TPs.....	13
7.3 Host Receives Data from GT9271.....	13
8. Description on Functions.....	14
8.1 Operating Modes.....	14
a) Normal Mode.....	14
b) Green Mode.....	14
c) Gesture Mode.....	15

d) Sleep Mode.....	15
e) Approach Mode.....	15
f) Receive Mode.....	16
g) Send Mode.....	16
8.2 Interrupt Triggering Mechanism.....	16
8.3 Sleep Mode.....	16
8.4 Stationary Configuration.....	16
8.5 Self-calibration.....	17
a) Self-calibration during Initialization.....	17
b) Automatic Drift Compensation.....	17
9. Sample Schematic.....	18
10. Electrical Characteristics.....	19
10.1 Absolute Maximum Ratings.....	19
10.2 Recommended Operating Conditions.....	19
10.3 AC Electrical Characteristics.....	19
10.4 DC Electrical Characteristics.....	20
11. Package.....	21
12. Revision History.....	22
13. Contact Information.....	23

1. Overview

GT9271, a new-generation 10-point capacitive touch solution designed for 7" to 10.1" portable devices, consists of up to 32 Transmitter electrodes and 20 Receiver electrodes to provide higher accuracy and resolution.

GT9271 supports up to 10 concurrent touches with real-time tracking of accurate position and motion trajectory as well as touch area. Furthermore, it is able to report such information to the host as required.

2. Features

- ◇ Built-in capacitive sensing circuit and high-performance MPU
 - Report rate: 100Hz
 - Outputs touch coordinates in real time
 - Unified software applicable to capacitive touch screens of various sizes
 - Single power supply, internal 1.8V LDO
 - Flash embedded; In-system reprogrammable
 - HotKnot integrated
- ◇ Capacitive touch sensor
 - Channels: 32 (Tx channels)*20(Rx channels)
 - Supports capacitive touch screen sizes: 7" to 10.1" (diagonal)
 - Supports touch key design on FPC
 - Supports ITO glass and ITO Film
 - Cover Lens thickness supported: 0.7mm ≅ Glass ≅ 2mm,
0.5mm ≅ Acrylic ≅ 1.2mm,
 - Supports OGS full lamination
- ◇ HotKnot
 - Transmission rate: 7.0Kbps(max)
 - Data frame maximum capacity: 128 bytes
 - Applicable sensor types: OGS/conventional, GFF/GG/GF
- ◇ Environmental adaptability
 - Self-calibration during initialization
 - Automatic drift compensation
 - Operating temperature: -40°C to +85°C; humidity: ≅ 95%RH
 - Storage temperature: -60°C to +125°C; humidity: ≅ 95%RH
- ◇ Host interface
 - Standard I²C interface
 - Works in slave mode

- Supports 1.8V to 3.3V host interface voltage
- ✧ Response time
 - Green mode: <48ms
 - Sleep mode: <200ms
 - Initialization: <200ms
- ✧ Power supply voltage:
 - Single supply: 2.8V to 3.3V
- ✧ Power supply ripple:
 - $V_{pp} \leq 50\text{mV}$
- ✧ Package: 68 pins, 8mm*8mm QFN
- ✧ Tools provided to support application development:
 - TP module parameter detector and generator
 - Integrated tool for TP module performance test
 - Tool for quality inspection during module mass-production
 - Reference driver code and documentary guide for host software development

3. Block Diagram

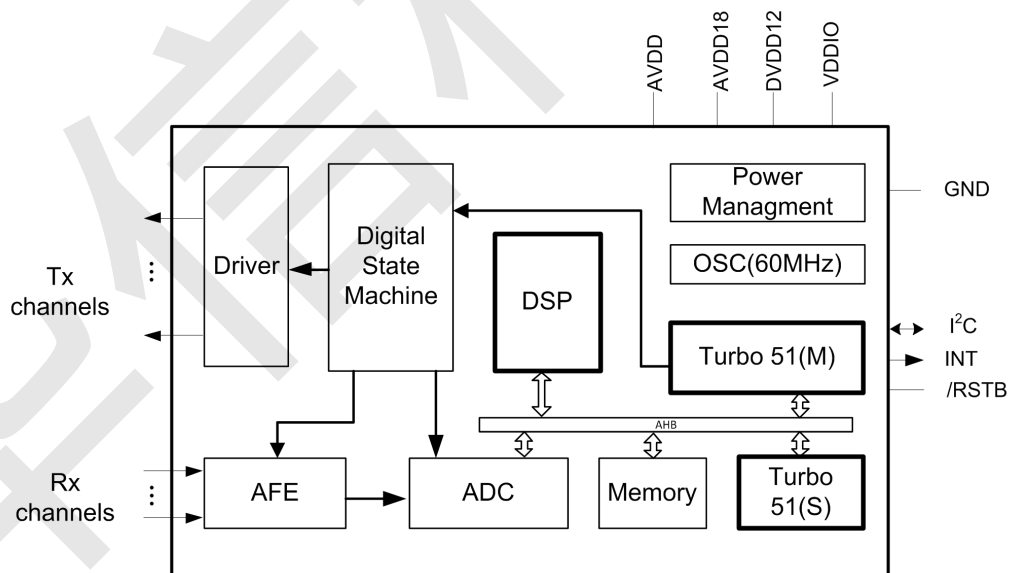

4. Pin Configurations

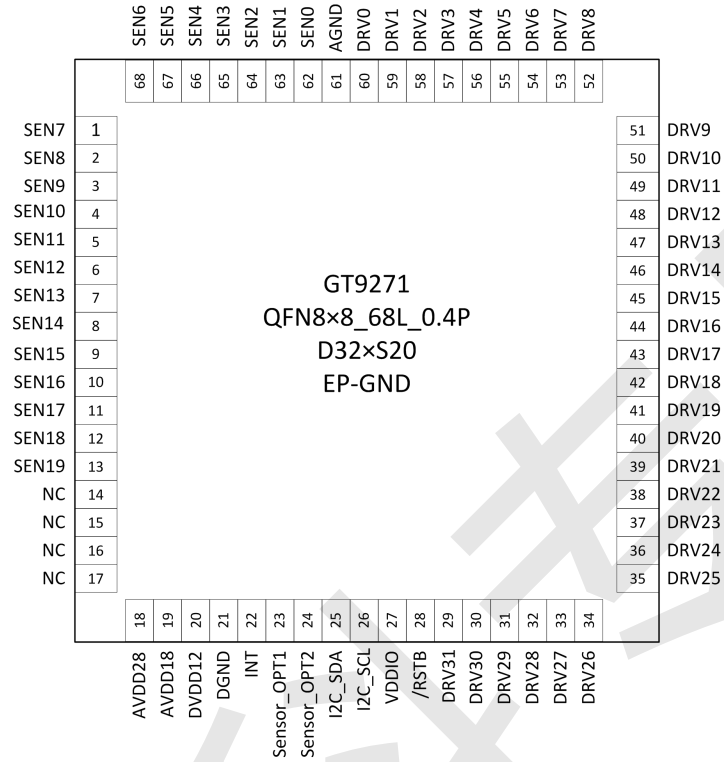

Pin No.	Name	Function description	Remarks
1~13	SENS7~SENS19	Receiver electrodes	Output drive signal while HotKnot function is on
14~17	NC	floating	
18	AVDD28	Analog power	2.2uF filter capacitor to GND
19	AVDD18		2.2uF filter capacitor to GND
20	DVDD12		2.2uF filter capacitor to GND
21	DGND	Digital signal ground	
22	INT	Interrupt signal	
23	Sensor_OPT1	Module ID pin	
24	Sensor_OPT2	Module ID pin	External pull-down resistor required
25	I2C_SDA	I ² C data signal	
26	I2C_SCL	I ² C clock signal	
27	VDDIO	Supply voltage of GPIO	2.2uF filter capacitor to GND Floating: 1.8V Connect to AVDD: AVDD
28	/RSTB	Reset pin	External 10K pull-up resistor required, active-low reset
29~60	DRV31~DRV0	Transmitter electrodes	
61	AGND	Analog signal ground	
62~68	SENS0~SENS6	Receiver electrodes	Output drive signal while HotKnot function is on

5. Sensor Design

5.1 Layout of Rx Channels

SENS0 to SENS19 are 20 Rx channels on the chip directly connected to 20 ITO Rx channels on the sensor either in sequence or reverse sequence. Please refer to *GT9 Series Channel Selector* for channel selection when there are less ITO Rx channels on the sensor than Rx channels on the chip.

Sample Layout: the ITO Rx channels on the sensor are connected to the Rx channels on the chip in sequence from SENS0 to SENS19:

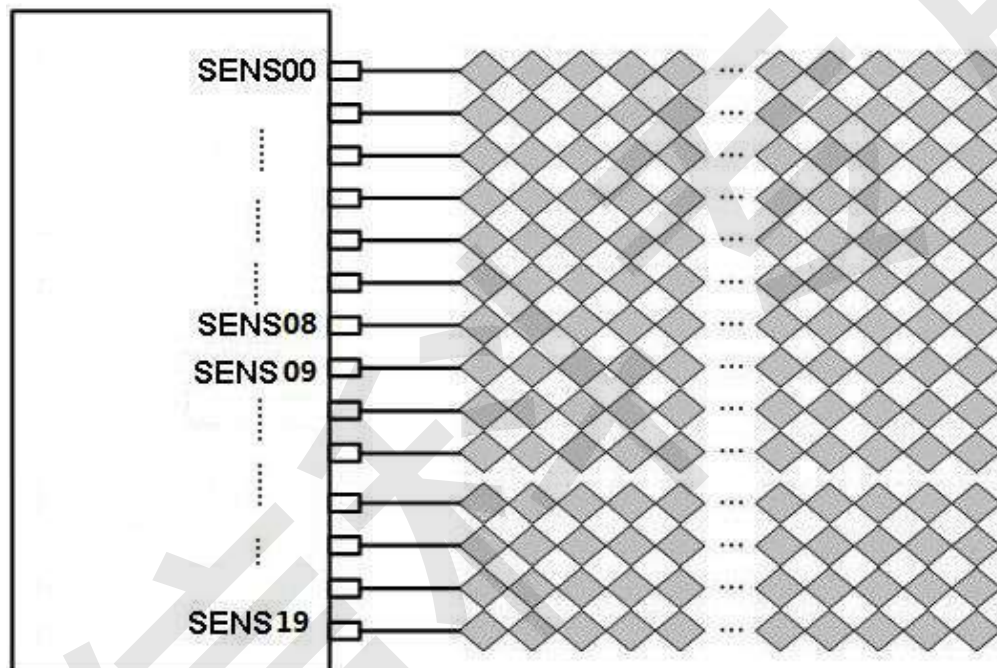

5.2 Layout of Tx Channels

DRV0 to DRV31 are 32 Tx channels on the chip directly connected to 32 ITO Tx channels on the sensor. Please refer to *GT9 Series Channel Selector* for channel selection and assignment.

After the layout of the Tx channels is determined, relevant registers of GT9271 shall be configured to ensure logic positions of Tx channels are consistent with their physical positions, so that the reported coordinates match the physical coordinates.

For details of sensor design, please refer to layout guidelines.

5.3 Sensor Design Specifications

GT9271	DITO	SITO
Tx routing trace Impedance	$\cong 3K\Omega$	$\cong 3K\Omega$
Tx channel Impedance	$\cong 10K\Omega$	$\cong 10K\Omega$
Rx routing trace Impedance	$\cong 10K\Omega$	$\cong 10K\Omega$
Rx channel Impedance	$\cong 40K\Omega$	$\cong 10K\Omega$
Node capacitance	$\cong 4pF$	$\cong 4pF$

To ensure data consistency and uniformity on the entire screen, it is necessary to ensure the sensor design complies with the above requirements. For detailed requirements, please refer to *Sensor Design Guidelines* of Goodix.

In addition, when Tx channel/trace and Rx channel/trace are adjacent and parallel to each other, separate the traces with a ground trace. For ground trace width, please refer to *Sensor Design Guidelines*. Note that ground trace width should not be less than 0.2mm.

5.4 Touch Key Design

GT9271 supports at most 4 separated touch keys in the following two ways:

- 1) *Touch key design on sensor*: Take one Tx channel as a common port for the touch keys and connect the Tx channel to four Rx channels to enable four touch keys. The touch keys must not share their Tx channel with the touch screen. However, Rx channels have to be shared.
- 2) *Touch key design on FPC*: Connect one separate Tx channel to four Rx channels to enable four touch keys. The touch keys have to share their Rx channels with the touch screen. Touch key pattern on FPC should be designed independently.

6. I²C Communication

6.1 I²C Timing

GT9271 provides a standard I2C interface for SCL and SDA to communicate with the host. GT9271 always serves as slave device in the system with all communication being initialized by the host. It is strongly recommended that transmission rate be kept at or below 400Kbps. The I2C timing is shown below:

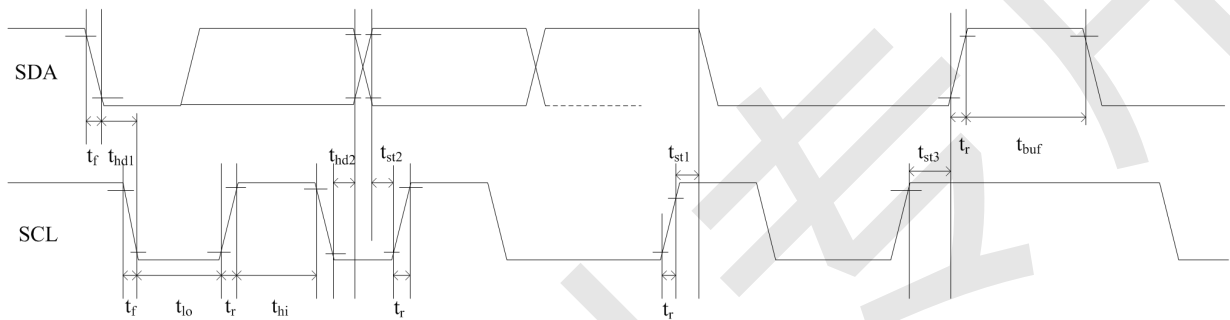

Test condition 1: 1.8V host interface voltage, 400Kbps transmission rate, 2K pull-up resistor

Parameter	Symbol	Min.	Max.	Unit
SCL low period	t_{lo}	1.3	-	us
SCL high period	t_{hi}	0.6	-	us
SCL setup time for Start condition	t_{st1}	0.6	-	us
SCL setup time for Stop condition	t_{st3}	0.6	-	us
SCL hold time for Start condition	t_{hd1}	0.6	-	us
SDA setup time	t_{st2}	0.1	-	us
SDA hold time	t_{hd2}	0	-	us

Test condition 2: 3.3V host interface voltage, 400Kbps transmission rate, 2K pull-up resistor

Parameter	Symbol	Min.	Max.	Unit
SCL low period	t_{lo}	1.3	-	us
SCL high period	t_{hi}	0.6	-	us
SCL setup time for Start condition	t_{st1}	0.6	-	us
SCL setup time for Stop condition	t_{st3}	0.6	-	us
SCL hold time for Start condition	t_{hd1}	0.6	-	us
SDA setup time	t_{st2}	0.1	-	us
SDA hold time	t_{hd2}	0	-	Us

GT9271 supports two I²C slave addresses: 0xBA/0xBB and 0x28/0x29. The host can select the address by changing the status of Reset and INT pins during the power-on initialization phase. See the diagram below for detailed timings:

Power-on Timing:

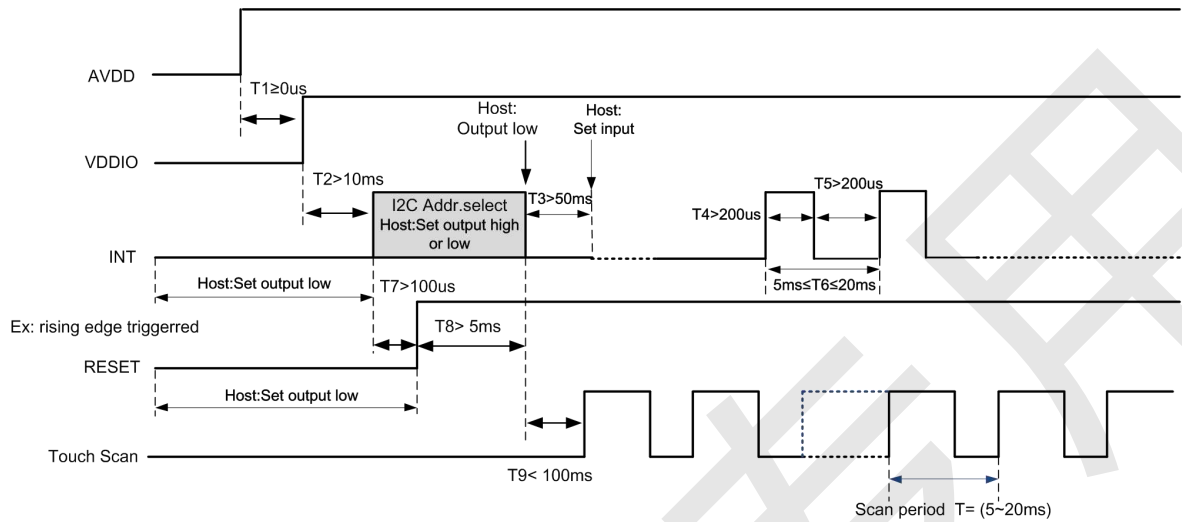

Timing for host resetting GT9271:

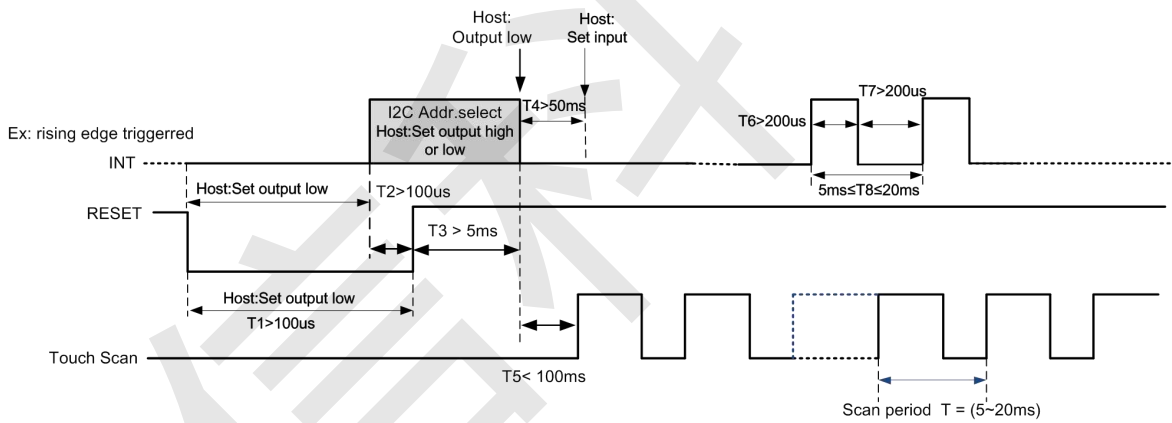

Timing for setting slave address to 0x28/0x29:

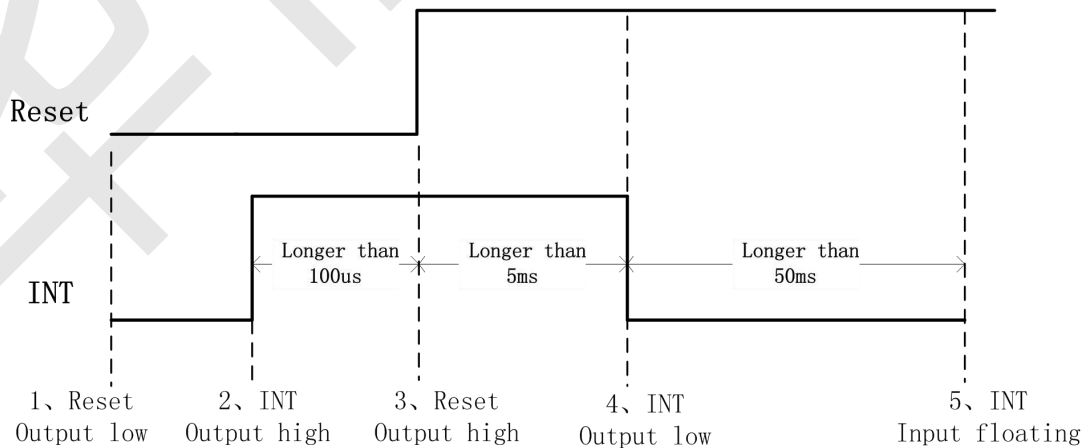

Timing for setting slave address to 0xBA/0xBB:

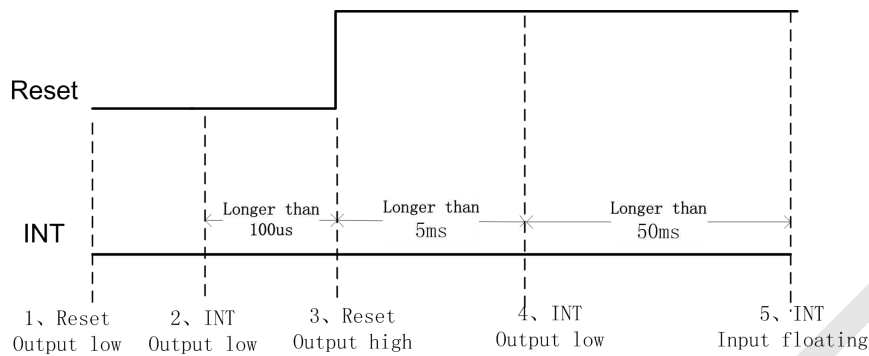

a) Data Transmission

(For example: slave address is 0xBA/0xBB)

Communication is always initiated by the host. Valid Start condition is signaled by pulling SDA line from high to low when SCL line is high. Data flow or address is transmitted after the Start condition.

All slave devices connected to I²C bus should detect the 8-bit address issued after Start condition and send the correct ACK. After receiving matching address, GT9271 acknowledges by configuring SDA line as output port and pulling SDA line low during the ninth SCL cycle. When receiving unmatched address, namely, not 0xBA or 0xBB, GT9271 will stay in an idle state.

For data bytes on SDA, each of 9 serial bits will be sent on nine SCL cycles. Each data byte consists of 8 valid data bits and one ACK or NACK bit sent by the recipient. The data transmission is valid when SCL line is high.

When communication is completed, the host will issue the Stop condition which implies the transition of SDA line from low to high when SCL line is high.

b) Writing Data to GT9271

(For example: slave address is 0xBA/0xBB)

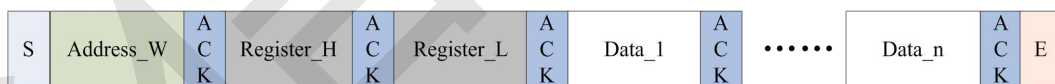

Timing for Write Operation

The diagram above displays the timing sequence of the host writing data onto GT9271. First, the host issues a Start condition. Then, the host sends 0xBA (address bits and R/W bit; R/W bit as 0 indicates Write operation) to the slave device.

After receiving ACK, the host sends the 16-bit register address (where writing starts) and the 8-bit data bytes (to be written onto the register).

The location of the register address pointer will automatically add 1 after every Write Operation. Therefore, when the host needs to perform Write Operations on a group of registers of continuous addresses, it is able to write continuously. The Write Operation is terminated when the host issues the Stop condition.

c) Reading Data from GT9271

(For example: slave address is 0xBA/0xBB)

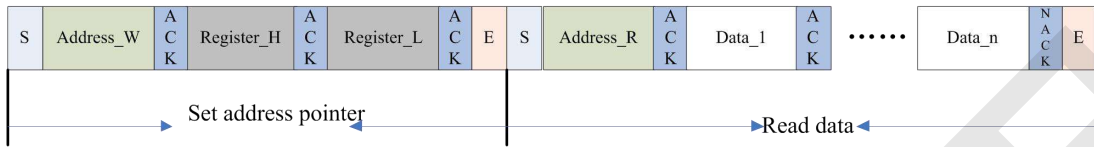

Timing for Read Operation

The diagram above is the timing sequence of the host reading data from GT9271. First, the host issues a Start condition and sends 0xBA (address bits and R/W bit; R/W bit as 0 indicates Write operation) to the slave device.

After receiving ACK, the host sends the 16-bit register address (where reading starts) to the slave device. Then the host sets register addresses which need to be read.

Also after receiving ACK, the host issues the Start condition once again and sends 0xBB (Read Operation). After receiving ACK, the host starts to read data.

GT9271 also supports continuous Read Operation and, by default, reads data continuously. Whenever receiving a byte of data, the host sends an ACK signal indicating successful reception. After receiving the last byte of data, the host sends a NACK signal followed by a STOP condition which terminates communication.

7. HotKnot

7.1 Start HotKnot

When data needs to be sent, the host sends command 0x21 to GT9271, enabling GT9271 to enter " Master Approach mode" and work as a transmitting terminal. GT9271 will then be able to detect the receiving terminal communicating with it. When GT9271 succeeds in detecting the receiving terminal, it will notify the the host to shut off LCD using an interrupt signal and then transmit data to the receiveing terminal.

7.2 Data Transmission between TPs

After GT9271 and another Hotknot terminal successfully detect one another, the host sends the HotKnot transmission firmware to both terminals. While the transmission firmware runs, the two terminals are ready for data transmission, entering Receive mode by default. When the GT9271 Transmit Buffer is flushed correctly, GT9271 works as the transmitting terminal and immediately transmits data to the other HotKnot terminal, which works as a receiving terminal detecting data sent by GT9271.

7.3 Host Receives Data from GT9271

Following recieval or transmission of a data frame, GT9271 inverts INT to notify the host to process data.

After receiving a data frame, the the host reads the value of the HotKnot-featured status register. If the value of the receive-status register indicates a successful reception, the host will read the data from the Receive Buffer via 12C. After reading the recieved data, the host writes 0xAA to the designated address and notifies GT9271 that data reading is complete.

After GT9271 transmits a data frame, the host reads the value of the HotKnot-featured status register. If the value of the transmit-status register indicates a successful transmission, the host will read the data from the Transmit Buffer via 12C. After reading this data, the host writes 0xAA to the designated address and notifies GT9271 that data reading is complete. GT9271 will automatically switch to Receive mode and will not start transmitting until Transmit Buffer is flushed again.

8. Description on Functions

8.1 Operating Modes

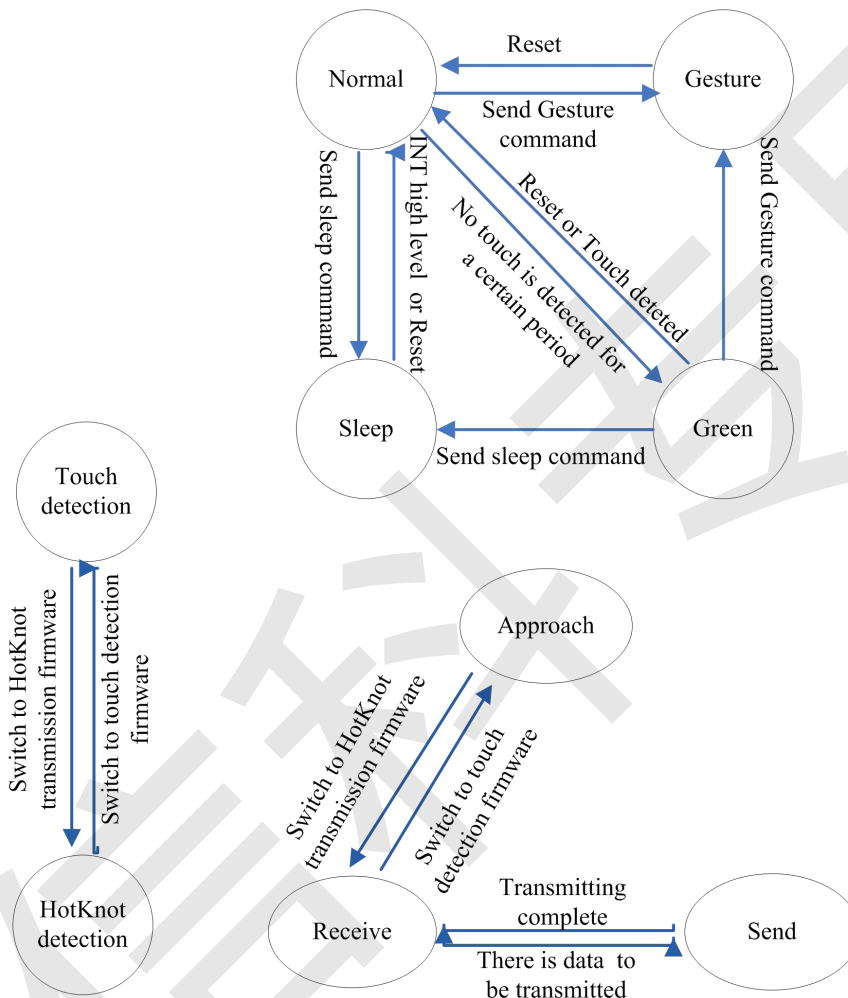

a) Normal Mode

When GT9271 is operating in Normal mode, its coordinate refresh period is subject to configuration (5ms to 20ms valid, one step is 1ms).

When no touch is detected for a certain period (0s to 15s, subject to configuration; one step is 1s) in Normal mode, GT9271 will automatically switch to Green mode to reduce power consumption.

b) Green Mode

In Green mode, the scan period for GT9271 is about 40ms. It automatically enters Normal mode if any touch is detected.

c) Gesture Mode

After the host enables GT9271 to enter Gesture mode by sending I²C command 8 to 0x8046 and then to 0x8040. Wake-up can be achieved by swipe, double-tap, or writing of specified lower-case letters on Touch Panel (TP).

In Gesture mode, when GT9271 detects any finger swipe for a sufficiently long distance, double-tap or writing of specified letters on TP, INT will output a pulse for longer than 250us or output a high level. The host will wake up and turn on the screen after receiving such pulse and high level.

d) Sleep Mode

GT9271 enters Sleep mode if it receives the corresponding I²C command from the host (require INT output low before the command). GT9271 exits Sleep mode and enters Normal mode when host outputs a high level to INT pin for 2ms to 5ms. The interval between sending screen-off command and wake-up should be longer than 58ms.

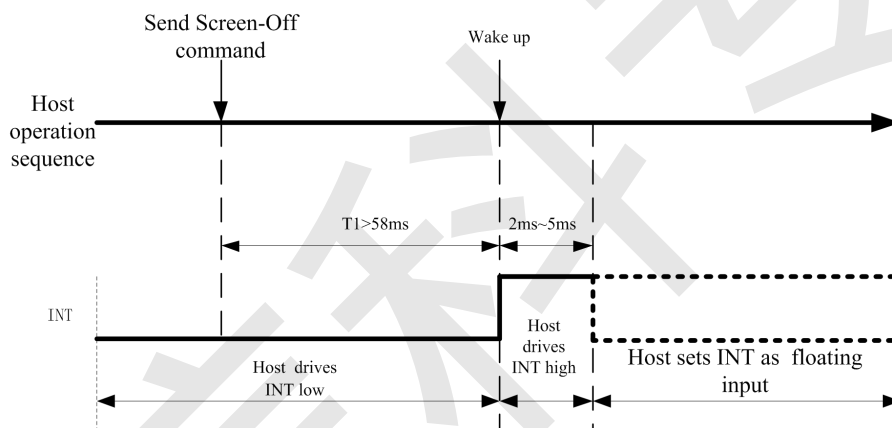

e) Approach Mode

When HotKnot proximity detection is enabled, GT9271 enters Approach mode by default. If GT9271 exits Approach mode, the host can send command 0x20 or 0x21 to enable GT9271 to enter Approach mode again. In this mode, touch detection and HotKnot proximity detection alternate. If the host sends 0x21 to GT9271, GT9271 will work as a transmitting terminal and transmit signals with a specified pattern and frequency via Tx and Rx channels. Then, GT9271 detects whether there are feedback signals with the same specified pattern and frequency from the receiving terminal. This helps to determine whether any receiving terminal exists. If the host sends 0x20 to GT9271, GT9271 will work as a Receiving terminal and detect signals with a specified pattern and frequency from the transmitting terminal. If such a signal is detected, GT9271 responds using signals with the specified pattern and frequency to the transmitting terminal. In Approach mode, when detecting any HotKnot-compatible terminal within the near-field range, GT9271 will notify the host via INT to capture status. To ensure reliable detection between the transmitting terminal and the receiving terminal, it is required to keep detecting for a minimum of 150ms after the two terminals have detected each other. Then the host sends HotKnot transmission firmware to enable GT9271 to enter Receive mode.

f) Receive Mode

In Approach mode, after notified that GT9271 has successfully detected another HotKnot terminal, the host sends HotKnot transmission firmware to enable GT9271 to enter Receive mode. In Receive mode, GT9271 continues to detect frame start signal, once the signal is detected, GT9271 begins to detect and receive data. When the receiving process is complete, GT9271 verifies the data. If GT9271 finds erroneous data, the receiving process begins again. If the data is found to be correct, GT9271 notifies the host via INT to read data in the Receive Buffer.

g) Send Mode

When GT9271 works in Receive mode, the host sends outgoing data to the Transmit Buffer. When detecting that the Transmit Buffer is flushed and there is data to be sent, GT9271 automatically switches from Receive mode to Send mode. In Send mode, GT9271 sends a frame start signal. If it detects ACK fed back from the receiving terminal, it continues to send the data signal. After sending a data chunk, GT9271 begins to detect ACK. If it does not detect any ACK or if it detects an erroneous ACK, GT9271 will resend the data chunk. If this resending fails over 5 times, it will resend the current data frame another time to the receiving terminal until the host enables GT9271 to exit Send mode due to timeout. If GT9271 detects ACK and sends the data successfully, it will automatically switch to Receive mode after the host completes the data processing or due to timeout.

8.2 Interrupt Triggering Mechanism

When touched, GT9271 sends a pulse via INT pin in every scanning cycle to notify the host to read coordinates. Host will then set a triggering mechanism via relevant register "INT" bit. INT as "0" indicates rising edge-triggered, which means GT9271 will notify the host by driving INT output from low to high when operated by user; INT as "1" indicates falling edge-triggered, which means GT9271 will notify the host by driving INT output from high to low when operated by user .

8.3 Sleep Mode

When the touch screen is off or there are no running operations on the TP, the host sends I²C command to enable GT9271 to enter Sleep mode, which reduces power consumption. When GT9271 needs to operate, the host outputs a high level to INT pin for a certain period to awake it. For detailed timings of host enabling GT9271 to enter and exit Sleep mode, please refer to section 8.1.

8.4 Stationary Configuration

GT9271 supports Stationary Configuration. After receiving configuration parameters from the host, GT9271 will fix parameters to the latest version. Once these parameters are fixed, GT9271 will communicate with the host solely via I²C bus and will not receive any parameters of previous versions from the host.

8.5 Self-calibration

a) Self-calibration during Initialization

Fluctuations in temperature, humidity and environment may affect the baseline of the capacitive sensor in idle state. GT9271 will update detection baseline according to environmental conditions within the first 200 ms of initialization. Then, GT9271 will complete the initialization of the TP test.

b) Automatic Drift Compensation

Gradual changes in environmental factors such as temperature, humidity, or dust may also affect the baseline of the capacitive sensor in idle state. GT9271 will detect real-time changes in data and perform statistic analysis of historic data to revise the baseline and thus reduce the impact that environmental changes have on the TP test.

9. Sample Schematic

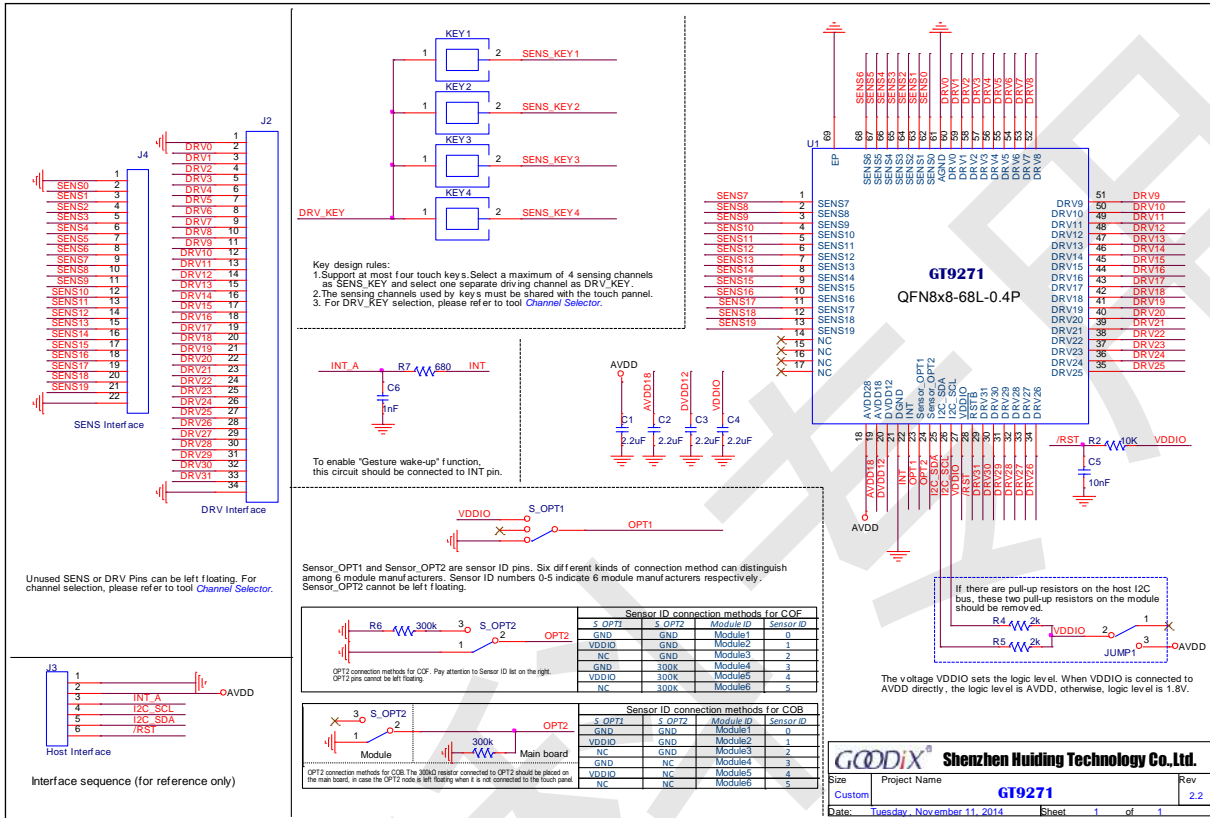

GT9271 sample schematic

Note:

- This schematic only represents basic application. Adjustments may be required to fit in with actual situations and application environments.
- It is recommended that the capacitor be ceramic X7R.

10. Electrical Characteristics

10.1 Absolute Maximum Ratings

(Ambient temperature: 25°C)

Parameter	Min.	Max.	Unit
Analog power AVDD28 (please refer to AGND)	2.66	3.47	V
VDDIO (please refer to DGND)	1.7	3.47	V
Voltage acceptable to digital I/O	-0.3	3.47	V
Voltage acceptable to analog I/O	-0.3	3.47	V
Range of operating temperature	-40	85	°C
Range of storage temperature	-60	125	°C
Welding temperature (10s)		300	°C
ESD protection voltage (HB Model)	—	±2	KV

10.2 Recommended Operating Conditions

Parameter	Min.	Typ.	Max.	Unit
AVDD28	2.8	-	3.3	V
VDDIO	1.8	-	3.3	V
Operating temperature	-20	25	85	°C

10.3 AC Electrical Characteristics

(Ambient temperature: 25°C, AVDD=2.8V, VDDIO=1.8V)

Parameter	Min.	Typ.	Max.	Unit
OSC oscillation frequency	59	60	61	MHz
I/O output rise time, low to high	-	14		ns
I/O output fall time, high to low	-	14		ns

10.4 DC Electrical Characteristics

(Ambient temperature:25℃, AVDD=2.8V, VDDIO=1.8V or VDDIO=AVDD)

Parameter	Min.	Typ.	Max.	Unit
Normal mode operating current	-	13	-	mA
Green mode operating current	-	4.5	-	mA
Gesture mode operating current		1.2	-	mA
Sleep mode operating current	70	-	120	uA
Input low voltage/VIL	-0.3		0.25*VDDIO	V
Input high voltage/VIH	0.75*VDDIO		VDDIO+0.3	V
Output low voltage/VOL			0.15*VDDIO	V
Output high voltage/VOH	0.85*VDDIO			V

11. Package

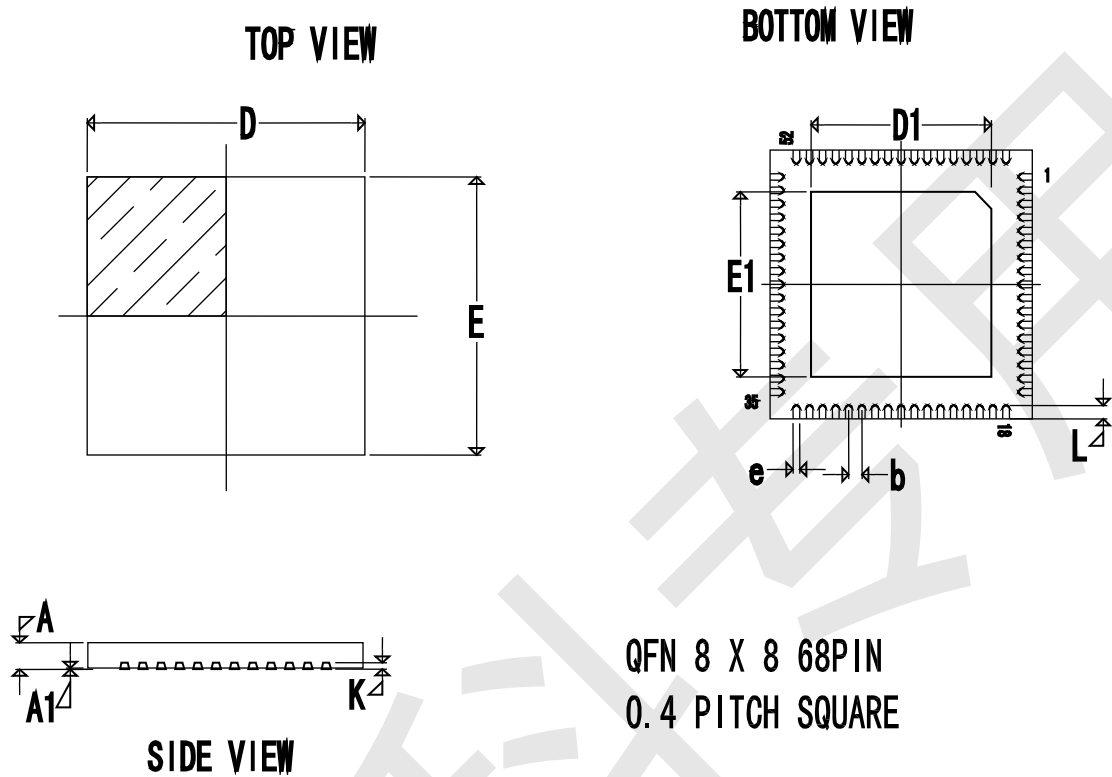

Symbol	Dimensions In Millimeters		
	Min.	Normal	Max.
A	0.70	0.75	0.80
A1	0.00	0.035	0.05
b	0.40BSC		
D	8.00BSC		
D1	5.40	5.50	5.60
E	8.00BSC		
E1	5.40	5.50	5.60
e	0.15	0.20	0.25
L	0.30	0.40	0.50
K	0.203BSC		

12. Revision History

Revision	Date	Description
Rev.00	2013-09-04	Preliminary release
Rev.01	2013-03-26	<ul style="list-style-type: none"> Updated power-on timing Added resetting timing Updated IIC address selection timing Deleted register map Modified operating modes Added description on Gesture mode Updated sleep mode timing Updated sample schematic Updated DC characteristic
Rev.02	2014-07-18	Updated power-on and reset timings
Rev.03	2014-10-14	<ul style="list-style-type: none"> Added HotKnot to product features Modified pin definitions Added description on HotKnot Modified description on Normal mode and Gesture mode Modified DC characteristics
Rev.04	2014-11-11	<ul style="list-style-type: none"> Updated sample schematic Modified Electrical Characteristics

13. Contact Information



Shenzhen Huiding Technology Co., Ltd.

Floor 13, Phase B, Tengfei Industrial Building, Futian Free Trade Zone

Shenzhen 518000

TEL: +86-755-33338828

FAX: +86-755-33338828

www.goodix.com