



EK73217A

Rev. 1.0

DATA SHEET

1200/1152/1080/960-Output
TFT LCD Gate Driver

fitipower integrated technology Inc.

Table of Contents

	Page
1. GENERAL DESCRIPTION	2
2. FEATURES	2
3. BLOCK DIAGRAM	3
4. PIN DESCRIPTION	4
5. FUNCTION DESCRIPTION	7
5.1. Device operation	7
5.2. Device power supply	7
5.3. Power ON/OFF sequence	8
5.4. Start Pulse LIMITATION	9
5.5. Output Sequence and Frame Control	10
6. ELECTRICAL SPECIFICATION	12
6.1. Absolute Maximum Ratings	12
6.2. Recommended Operating Range	12
6.3. DC Characteristics	13
6.4. AC Characteristics	14
6.5. Timing Waveform	14
6.6. Operation Timing	16
7. CHIP OUTLINE DIMENSIONS AND ALIGNMENT MARK	17
8. BUMP CENTER COORDINATE	18
9. DEFINITIONS	25
9.1 Data Sheet Status	25
9.2 Life Support Application	25
10 REVISION HISTORY	25

1200/1152/1080/960-Output TFT LCD Gate Driver**1. GENERAL DESCRIPTION**

The EK73217A is a 1200/1152/1080/960-Output gate driver used for driving the gate electrode of TFT LCD panel. It is designed for 2-level output with maximum +40V output driving voltage.

2. FEATURES

- 2-level output gate driver for TFT LCD panel
- 1200/1152/1080/960-Output gate driver with 2 dummy outputs which are fixed to VGL
- Maximum +40V output driving voltage
- Logic operating voltage (VCC): 1.7 ~ 3.6V
- Bi-directional data shift capability
- 200 KHz maximum operation frequency
- High voltage CMOS process technology
- COG package
- Chip size=23650*670 μ m
- Output bump pitch=18 μ m

3. BLOCK DIAGRAM

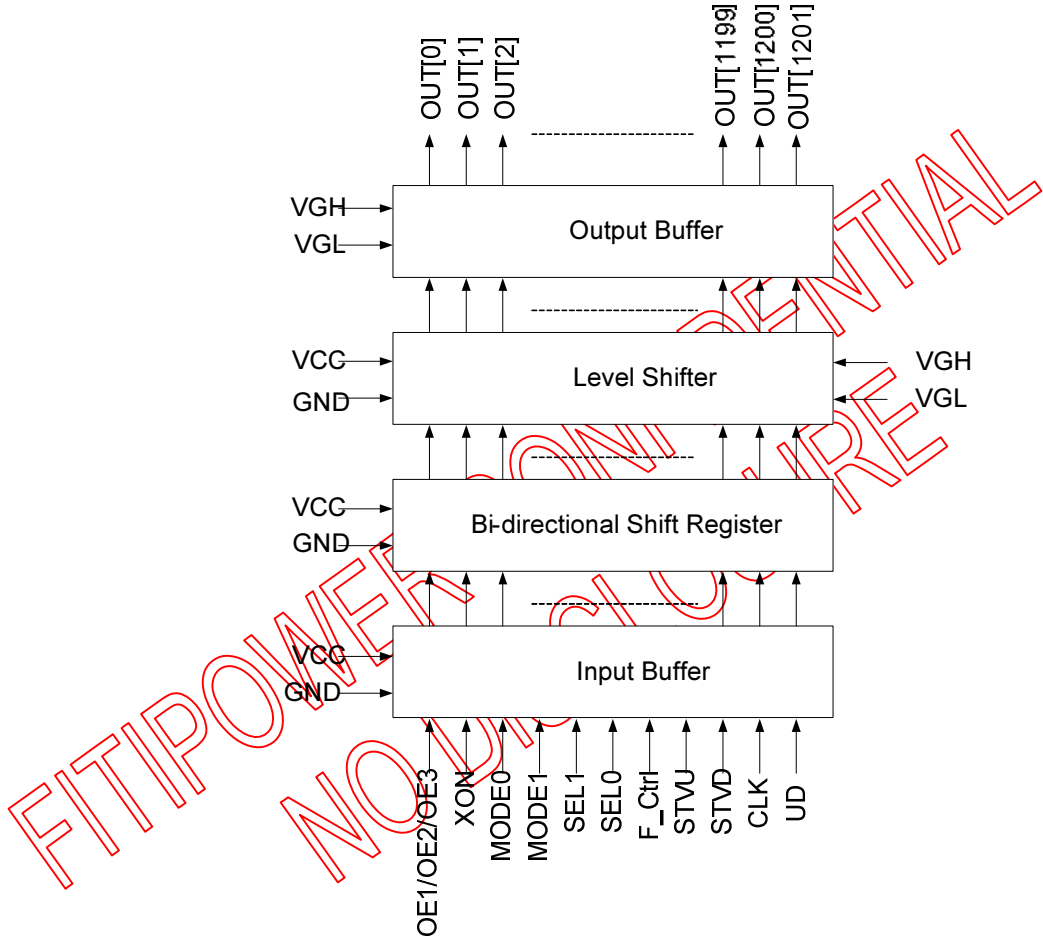

Figure 1. Block Diagram

4. PIN DESCRIPTION

Pin Name	Pin Type	Description									
CLKR/CLKL	I	This is the clock input for chip internal shift register. Data is shifted at each rising edge of this clock.									
UDR/UDL	I	This pin controls the output shifting direction as listed below. UD = H: STVD(input)→OUT[1]→OUT[2]→...→OUT[1200]→STVU UD = L: STVU(input)→OUT[1200]→...→OUT[2]→OUT[1]→STVD									
STVD STVU	I/O	These two pins are the device start pulse input or output pin. The function of these two pins depends on the status of UD pin. <table border="1" style="margin-left: auto; margin-right: auto;"> <thead> <tr> <th></th> <th>STVD</th> <th>STVU</th> </tr> </thead> <tbody> <tr> <td>UD = H</td> <td>input</td> <td>output</td> </tr> <tr> <td>UD = L</td> <td>output</td> <td>input</td> </tr> </tbody> </table>		STVD	STVU	UD = H	input	output	UD = L	output	input
	STVD	STVU									
UD = H	input	output									
UD = L	output	input									
OE1R/OE1L	I	The OE1 signal controls the OUT1, OUT4, OUT7...OUT1195, OUT1198 output enable. OE1,2,3="H": outputs are fixed to VGL regardless of CLK, However, the content of shift register is not cleared. OE1,2,3="L": Normal operation.									
OE2R/OE2L	I	The OE1 signal controls the OUT2, OUT5, OUT8...OUT1196, OUT1199 output enable. OE1,2,3="H": outputs are fixed to VGL regardless of CLK, However, the content of shift register is not cleared. OE1,2,3="L": Normal operation.									
OE3R/OE3L	I	The OE1 signal controls the OUT3, OUT6, OUT9...OUT1197, OUT1200 output enable. OE1,2,3="H": outputs are fixed to VGL regardless of CLK, However, the content of shift register is not cleared. OE1,2,3="L": Normal operation.									
XONR/XONL	IPH	When XON input pin is L, all the output pins are forced to VGH level. Note that this pin has higher priority than OE1/OE2/OE3. Also it has an internal pull high resistor, keep it to VCC is preferred when unused. The chip internal shift register is not cleared when XON input is active.									

MODE0R MODE0L MODE1R MODE1L	IPH	<p>Output channels select input. MODE0/MODE1 are internally pulled high.</p> <p>Note: This pin should be connected to either "VCC" or "GND".</p> <table border="1"> <thead> <tr> <th>MODE1</th> <th>MODE0</th> <th>Output Channels</th> <th>Disable channel</th> </tr> </thead> <tbody> <tr> <td>1</td> <td>1</td> <td>1200</td> <td>-</td> </tr> <tr> <td>1</td> <td>0</td> <td>1152</td> <td>OUT[577] ~ OUT[624]</td> </tr> <tr> <td>0</td> <td>1</td> <td>1080</td> <td>OUT[541] ~ OUT[660]</td> </tr> <tr> <td>0</td> <td>0</td> <td>960</td> <td>OUT[481] ~ OUT[720]</td> </tr> </tbody> </table>	MODE1	MODE0	Output Channels	Disable channel	1	1	1200	-	1	0	1152	OUT[577] ~ OUT[624]	0	1	1080	OUT[541] ~ OUT[660]	0	0	960	OUT[481] ~ OUT[720]
MODE1	MODE0	Output Channels	Disable channel																			
1	1	1200	-																			
1	0	1152	OUT[577] ~ OUT[624]																			
0	1	1080	OUT[541] ~ OUT[660]																			
0	0	960	OUT[481] ~ OUT[720]																			
SEL0R SEL0L SEL1R SEL1L	IPL	<p>Output sequence control inputs. These two pins control the driver output sequence. Internally pulled low.</p> <table border="1"> <thead> <tr> <th>SEL1</th> <th>SEL0</th> <th>Scan Type</th> </tr> </thead> <tbody> <tr> <td>1</td> <td>1</td> <td>Z+ Bow</td> </tr> <tr> <td>0</td> <td>1</td> <td>Bow</td> </tr> <tr> <td>X</td> <td>0</td> <td>Z</td> </tr> </tbody> </table>	SEL1	SEL0	Scan Type	1	1	Z+ Bow	0	1	Bow	X	0	Z								
SEL1	SEL0	Scan Type																				
1	1	Z+ Bow																				
0	1	Bow																				
X	0	Z																				
F_CtrlL F_CtrlR	IPL	<p>Frame control input. This pin decides to inverse the output sequence or not in odd or even frame. Internally pulled low.</p>																				
OUT[1] ~ OUT[1200]	O	<p>The output voltage is either VGH or VGL for driving the gate electrode of TFT LCD panel depending on the data stored in shift register and the state of OE.</p>																				
OUT[0] OUT[1201]	O	<p>LCD panel auxiliary pins, these pins always output VGL level.</p>																				

Pin Name	Pin Type	Description
VCC	P	Digital power
GND	P	Digital ground
VGH	P	Power supply for OUT[1] ~ OUT[1200] drive output High
VGL	P	Power supply for OUT[1] ~ OUT[1200] drive output Low.
PATH1R,PATH1L PATH2R,PATH2L PATH3R,PATH3L	-	Linked together internal.
DUM2~DUM220	-	This pin is connected to GND internally. Not connected.

Note:

I: Input, IPH: Input with internal pull high, IPL: Input with internal low, O: Output, P: Power.

Pass line name

Pass line No.	Pad name	
1	OE1R	OE1L
2	OE2R	OE2L
3	OE3R	OE3L
4	UDR	UDL
5	CLKR	CLKL
6	PATH1R	PATH1L
7	PATH2R	PATH2L
8	PATH3R	PATH3L
9	VGH	VGH
10	VGL	VGL
11	VCC	VCC
12	GND	GND
13	MODE0R	MODE0L
14	MODE1R	MODE0L
15	SEL0R	SEL0L
16	SEL1R	SEL1L
17	F_CtrlR	F_CtrlL
18	XONR	XONL

5. FUNCTION DESCRIPTION

5.1. Device operation

In the condition of UD=H, the STVD start pulse input is sensed at the rising edge of CLK and stored in the first stage of shift register, which causes the first scan signal is output from the X1 output pin. While stored data is transferred to the next stage shift register at the rising edge of next CLK, new data of STVD is sensed and stored simultaneously.

The output pin (OUT[1] to OUT[1200]) supplies VGH voltage or VGL voltage to the LCD panel depending on the data stored in the shift register. For normal operation, a VGH voltage is output one by one from OUT[1] to OUT[1200] in sync with CLK pulse.

After 1200 CLK rising edge are past, the STVU goes up to high level at the 1200th falling edge of CLK and goes down to low level at the 1201th falling edge of CLK. This STVU output signal becomes the STVD start pulse input of next cascaded gate driver device.

During any "H" state of OE, the corresponding output channels are forced to VGL level regardless of CLK. The channel output returns to normal status as soon as OE go back to "L".

5.2. Device power supply

The EK73217A must be used by the following conditions.

* $VGH - VGL = 40V$ (max.)

* $VGH - GND = 7 \sim 35V$

Example:

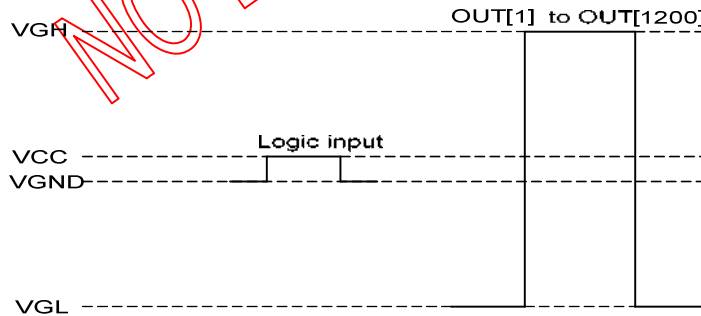

Figure 2. Device power supply

The input signal level of CLK, UD, OE, STVD, STVU, MODE0, MODE1, SEL1, SEL0, and F_ctrl have to swing between VCC and GND. The signal output level of start pulse (STVU or STVD) to the next stage cascaded device is VCC for “H” and GND for “L”.

5.3. Power ON/OFF sequence

To prevent the device from damage due to latch up, the power ON/OFF sequence shown below must be followed.

When power on: VCC→VGL→VGH

When power off: VGH→VGL→VCC

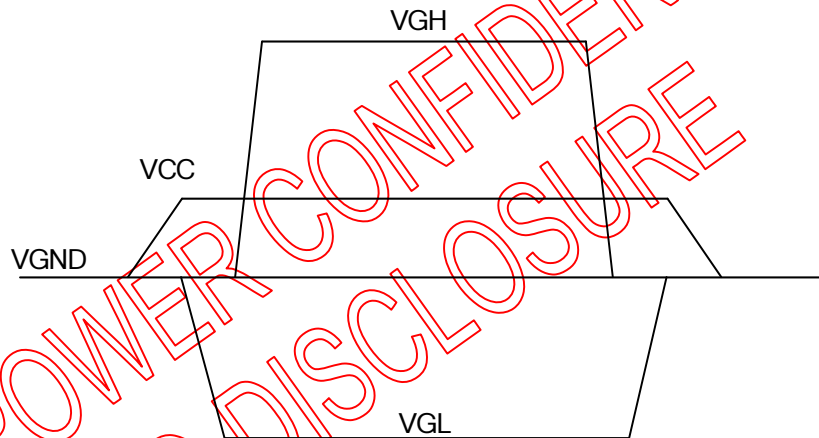

Figure 3. Power ON/OFF sequence

5.4. Start Pulse LIMITATION

The available start pulse is in the following diagram.

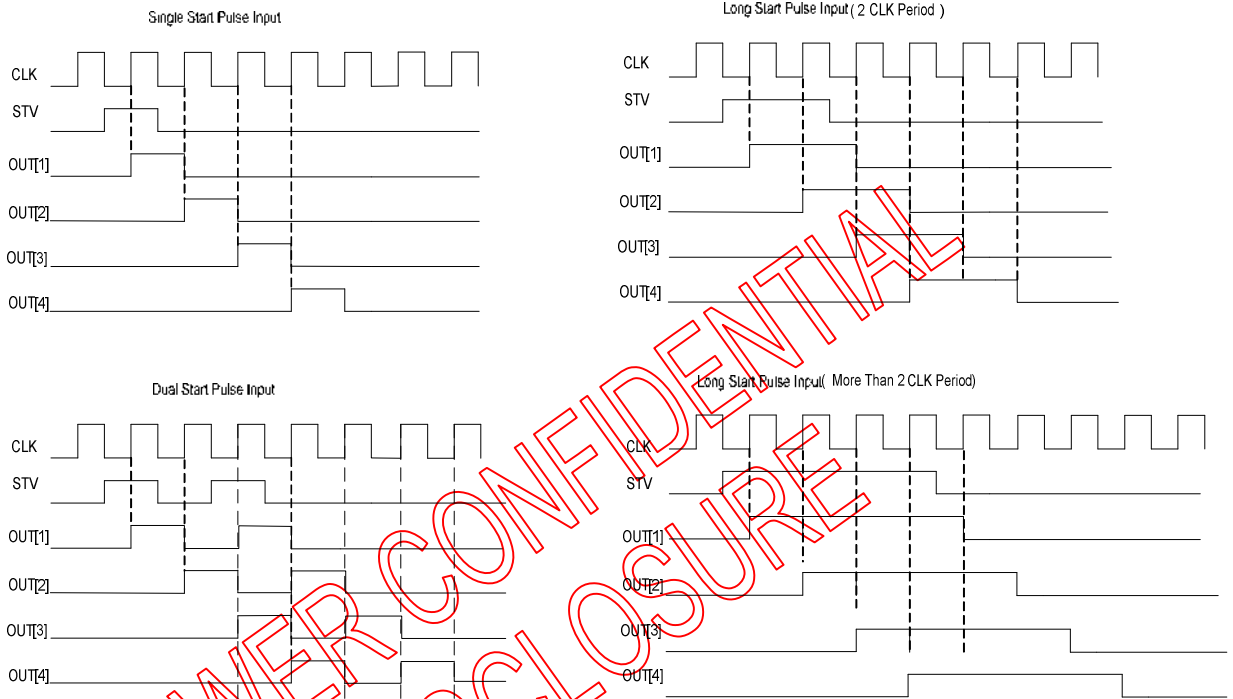
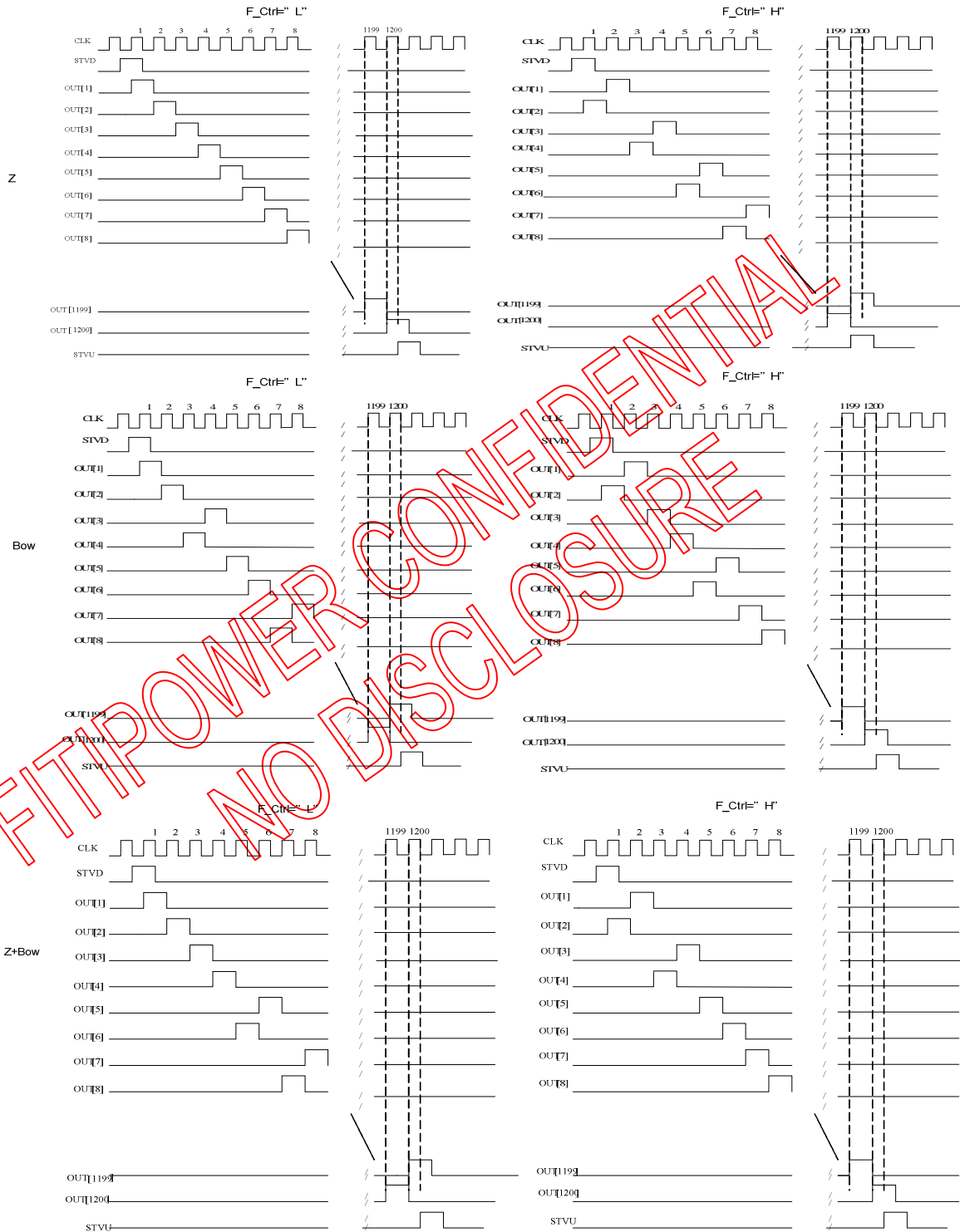

Figure 4. Start pulse Input limitation

Note: However the start pulse form changes, gate output keeps output sequentially.

5.5. Output Sequence and Frame Control

UD = H				
SEL0	SEL1	F_Ctrl	Scan Type	Output Sequence
1	1	0	Z + BOW	1→2→3→4→6→5→8→7→... (Note1)
		1	Inverse (Z+BOW)	2→1→4→3→5→6→7→8→...
1	0	0	BOW	1→2→4→3→5→6→8→7→... (Note2)
		1	Inverse BOW	2→1→3→4→6→5→7→8→...
0	X	0	Z	1→2→3→4→5→6→7→8→... (Note 3)
		1	Inverse Z	2→1→4→3→6→5→8→7→... (Note 4)
UD = L				
SEL0	SEL1	F_Ctrl	Scan Type	Output Sequence
1	1	0	Z + BOW	...8→7→6→5→3→4→1→2
		1	Inverse (Z+BOW)	...7→8→5→6→4→3→2→1
1	0	0	BOW	...8→7→5→6→4→3→1→2
		1	Inverse BOW	...7→8→6→5→3→4→2→1
0	X	0	Z	...8→7→6→5→4→3→2→1
		1	Inverse Z	...7→8→5→6→3→4→1→2



FTIPOWER CONFIDENTIAL
NO DISCLOSURE

6. ELECTRICAL SPECIFICATION

6.1. Absolute Maximum Ratings

Absolute Maximum Ratings (GND = 0 V)

Parameter	Symbol	Rating	Unit
Power supply voltage (1)	VGH	-0.3 to +42.0	V
Power supply voltage (2)	VCC	-0.3 to +7.0	V
Power supply voltage (3)	VGL	-20 to +0.3	V
Power supply voltage (4)	VGH - VGL	-0.3 ~ +40	V
Input voltage	V _{IN}	-0.3 to VCC+0.3	V
Storage temperature	T _{STG}	-55 to +125	°C

Note 1: All of the voltages listed above are with respect to GND = 0V.

Note 2: Device is subject to be damaged permanently if stresses beyond those absolute maximum ratings listed above.

6.2. Recommended Operating Range

Recommended Operating Range (VGND = 0V)

Parameter	Symbol	Conditions	Rating			Unit
			Min.	Typ.	Max.	
Power supply voltage (1)	VGH	-	7	-	VGL+40	V
Power supply voltage (2)	VCC	-	1.7	-	3.6	V
Power supply voltage (3)	VGL	VCC=1.7V~2.3V	-10	-	-5	V
		VCC=2.3V~3.6V	-10	-	-3	V
Power supply voltage (4)	VGH - VGL	-	15	-	40	V
Operation frequency	FCLK	-	-	-	200	KHz
Operation temperature	T _a	-	-20	-	+85	°C

6.3. DC Characteristics

DC Characteristic (VGH = 25V, VGL = -15V, VCC = 3.3V/1.8V, GND = 0V, Ta = 25°C)

Parameter	Symbol	Condition	Rating			Unit	Application pin
			Min.	Typ.	Max.		
Input H voltage	V _{IH}	-	0.7VCC	-	VCC	V	All input
Input L voltage	V _{IL}	-	0	-	0.3VCC	V	All input
Output H voltage	V _{OH}	I _{OH} =40μA	VCC-0.4	-	VCC	V	STVU,D
Output L voltage	V _{OL}	I _{OL} =40μA	0	-	0.4	V	STVU,D
Output H resistance	R _{OH}	V _X = VGH -0.5V	-	-	1000	Ω	OUT[1] ~ OUT[1200]
Output L resistance	R _{OL}	V _X = VGL+0.5V	-	-	1000	Ω	OUT[1] ~ OUT[1200]
Input leakage current	I _{IN}	-	-1.0	-	+1.0	μA	Note ⁽²⁾
Pull high / low resistance	R _{PHL}	VCC=3.3V V _{IN} =VGND V _{IN} ≠VCC	50	-	330	kΩ	XON, SEL1, SEL0, F_CTRL
		VCC=1.8V V _{IN} =VGND V _{IN} =VCC	220	-	1080	kΩ	
VGH Power consumption	I _{VGH}	Note ⁽¹⁾	-	50	250	μA	-
VGL Power consumption	I _{VGH}	Note ⁽¹⁾	-	-50	-250	μA	-
VCC Power consumption	I _{VCC}	Note ⁽¹⁾	-	15	100	μA	-

Note 1: Power consumption with the following condition: Output no load, VGH=25V, VGL=-15V, VCC=3.3V, V_{IH} =VCC, V_{IL}=GND, F_{clk} = 50 KHz, OE = V_{IL}, XON= V_{IH}.

Note 2: All input except XON, SEL1, SEL0, FCTRL

6.4. AC Characteristics

AC Characteristics (VGH = 25V, VGL = -15V, VCC = 3.3V/1.8V, VGND = 0V, Ta = 25°C)

Parameter	Symbol	Condition	Rating			Unit
			Min.	Typ.	Max.	
CLK period	t_{CLK}	-	5	-	-	μs
CLK pulse width	t_{CLKH}, t_{CLKL}	50% duty cycle	2.5	-	-	μs
OE pulse width	t_{WOE}	VCC=1.7V~2.3V	1.3	-	-	μs
		VCC=2.3V~3.6V	1	-	-	μs
XON pulse width	t_{WXAO}	-	100	-	-	μs
Data setup time	t_{SU}	-	0.7	-	-	μs
Data hold time	t_{HD}	-	0.7	-	-	μs
CLK to output delay time	t_{PD1}	CL=300pF, VCC=1.7V~2.3V	-	-	1.5	μs
		CL=300pF, VCC=2.3V~3.6V	-	-	1.2	μs
Start pulse output delay time	t_{PD2}	CL=30pF, VCC=1.7V~2.3V	-	-	1.3	μs
		CL=30pF, VCC=2.3V~3.6V	-	-	1	μs
OE to output delay time	t_{PD3}	CL=300pF, VCC=1.7V~2.3V	-	-	1.3	μs
		CL=300pF, VCC=2.3V~3.6V	-	-	1	μs
XON to output delay time	t_{PD4}	CL=300pF	-	-	100	μs
F_Ctrl setup time	t_{MSU}		1.0			μs
F_Ctrl hold time	t_{MHD}		1.0			μs

Note 1: The measurement point for all of above signals is at 50% of input/output amplitude.

6.5. Timing Waveform

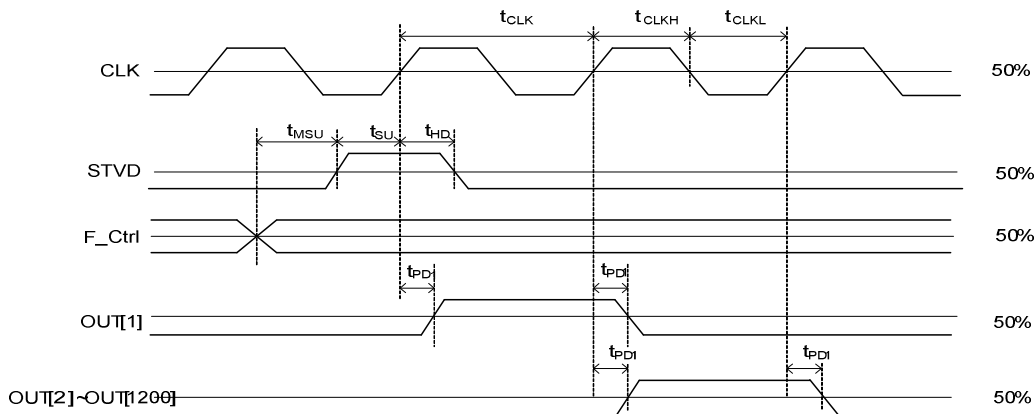

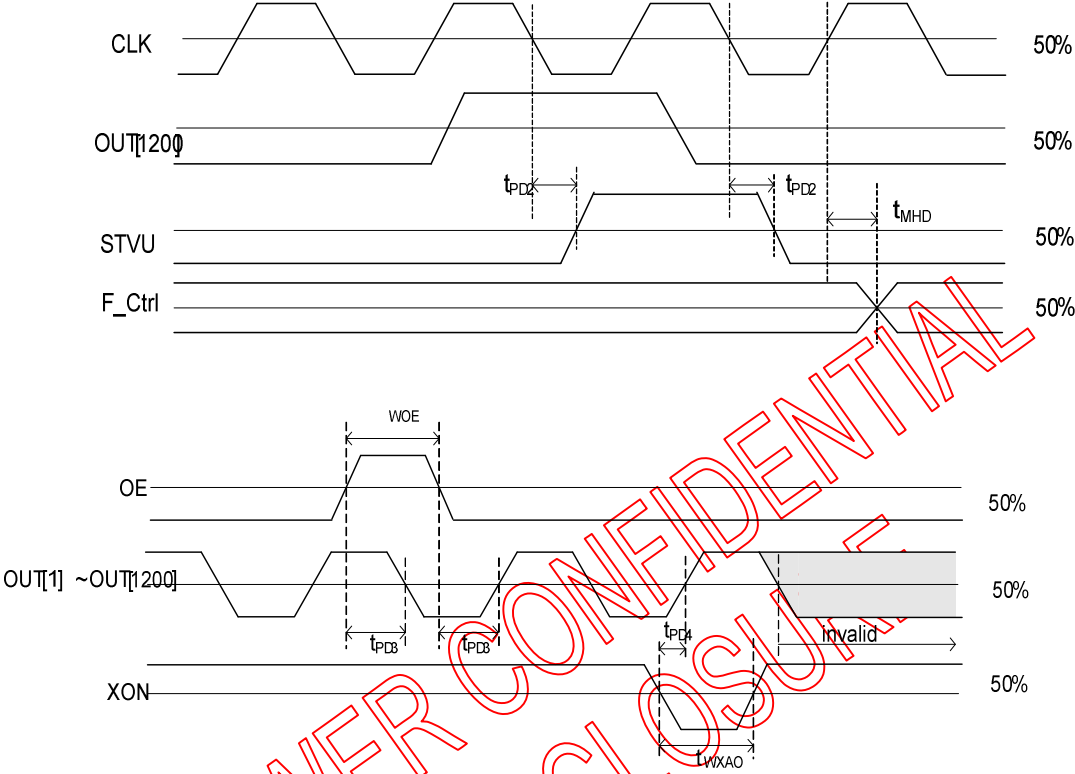

Figure 5. timing waveform

6.6. Operation Timing

UD="H"



Figure 6. Example of input/output timing (UD = H with OE and XON)

UD="L"

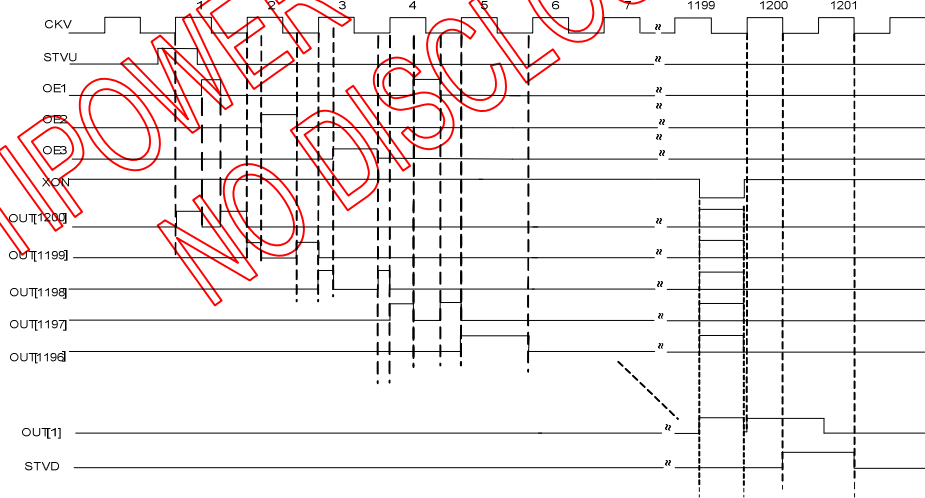
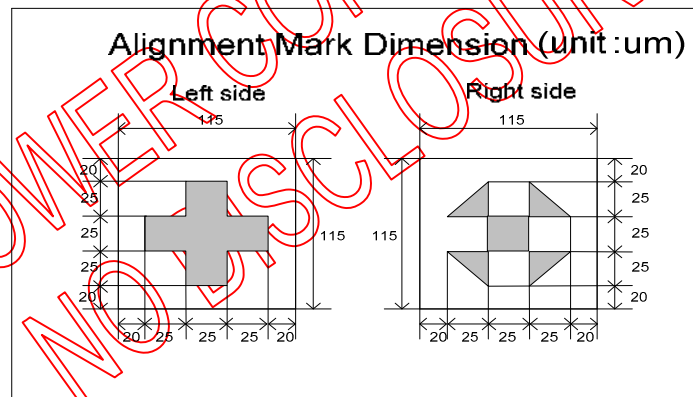
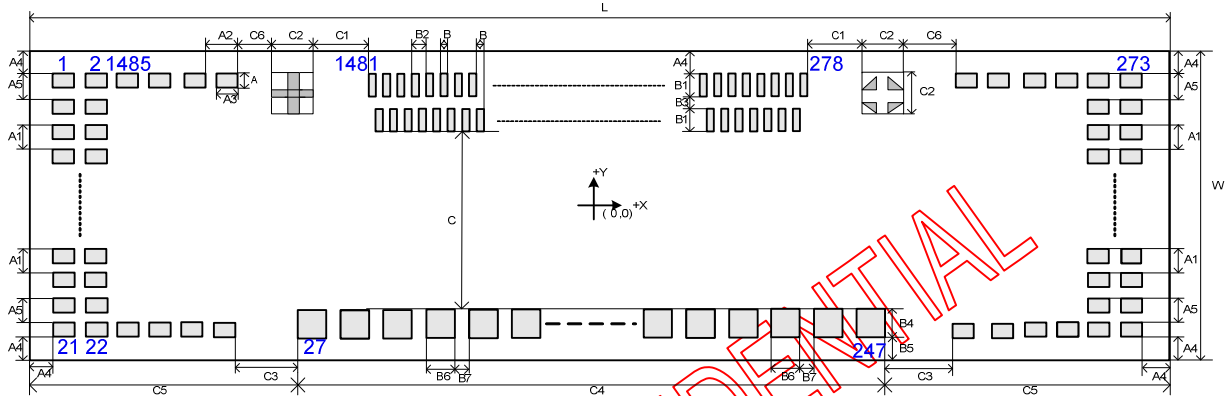

Figure 7. Example of input/output timing (UD = L with OE and XON)

7. CHIP OUTLINE DIMENSIONS AND ALIGNMENT MARK



Symbol	Dimensions	Symbol	Dimensions	Symbol	Dimensions
A	32	B2	36	C2	115
A1	52	B3	25	C3	208
A2	90	B4	70	C4	22080
A3	70	B5	57	C5	785
A4	57	B6	80	C6	89
A5	54	B7	20	L	23650
B	18	C	291	W	670
B1	85	C1	199	Unit : um	

8. BUMP CENTER COORDINATE

Pad #	Pad Name	Pad Coordinate		Pad #	Pad Name	Pad Coordinate		Pad #	Pad Name	Pad Coordinate	
		X	Y			X	Y			X	Y
1	OE1L	-11733	262	81	DUM55	-5600	-243	161	DUM135	2400	-243
2	OE1L	-11643	262	82	DUM56	-5500	-243	162	DUM136	2500	-243
3	OE2L	-11733	208	83	DUM57	-5400	-243	163	DUM137	2600	-243
4	OE2L	-11643	208	84	DUM58	-5300	-243	164	DUM138	2700	-243
5	OE3L	-11733	156	85	DUM59	-5200	-243	165	DUM139	2800	-243
6	OE3L	-11643	156	86	DUM60	-5100	-243	166	DUM140	2900	-243
7	UDL	-11733	104	87	DUM61	-5000	-243	167	DUM141	3000	-243
8	UDL	-11643	104	88	DUM62	-4900	-243	168	DUM142	3100	-243
9	CLKL	-11733	52	89	DUM63	-4800	-243	169	DUM143	3200	-243
10	CLKL	-11643	52	90	DUM64	-4700	-243	170	DUM144	3300	-243
11	PATH1L	-11733	0	91	DUM65	-4600	-243	171	DUM145	3400	-243
12	PATH1L	-11643	0	92	DUM66	-4500	-243	172	DUM146	3500	-243
13	STVUL	-11733	-52	93	DUM67	-4400	-243	173	DUM147	3600	-243
14	STVUL	-11643	-52	94	DUM68	-4300	-243	174	DUM148	3700	-243
15	VGH	-11733	-104	95	DUM69	-4200	-243	175	DUM149	3800	-243
16	VGH	-11643	-104	96	DUM70	-4100	-243	176	DUM150	3900	-243
17	VGL	-11733	-156	97	DUM71	-4000	-243	177	DUM151	4000	-243
18	VGL	-11643	-156	98	DUM72	-3900	-243	178	DUM152	4100	-243
19	VCC	-11733	-208	99	DUM73	-3800	-243	179	DUM153	4200	-243
20	VCC	-11643	-208	100	DUM74	-3700	-243	180	DUM154	4300	-243
21	GND	-11733	-262	101	DUM75	-3600	-243	181	DUM155	4400	-243
22	GND	-11643	-262	102	DUM76	-3500	-243	182	DUM156	4500	-243
23	MODE1L	-11553	-262	103	DUM77	-3400	-243	183	DUM157	4600	-243
24	MODE0L	-11463	-262	104	DUM78	-3300	-243	184	DUM158	4700	-243
25	SEL0L	-11373	-262	105	DUM79	-3200	-243	185	DUM159	4800	-243
26	SEL1L	-11283	-262	106	DUM80	-3100	-243	186	DUM160	4900	-243
27	PATH2L	-11000	-243	107	DUM81	-3000	-243	187	DUM161	5000	-243
28	DUM2	-10900	-243	108	DUM82	-2900	-243	188	DUM162	5100	-243
29	DUM3	-10800	-243	109	DUM83	-2800	-243	189	DUM163	5200	-243
30	DUM4	-10700	-243	110	DUM84	-2700	-243	190	DUM164	5300	-243
31	DUM5	-10600	-243	111	DUM85	-2600	-243	191	DUM165	5400	-243
32	DUM6	-10500	-243	112	DUM86	-2500	-243	192	DUM166	5500	-243
33	DUM7	-10400	-243	113	DUM87	-2400	-243	193	DUM167	5600	-243
34	DUM8	-10300	-243	114	DUM88	-2300	-243	194	DUM168	5700	-243
35	DUM9	-10200	-243	115	DUM89	-2200	-243	195	DUM169	5800	-243
36	DUM10	-10100	-243	116	DUM90	-2100	-243	196	DUM170	5900	-243
37	DUM11	-10000	-243	117	DUM91	-2000	-243	197	DUM171	6000	-243
38	DUM12	-9900	-243	118	DUM92	-1900	-243	198	DUM172	6100	-243
39	DUM13	-9800	-243	119	DUM93	-1800	-243	199	DUM173	6200	-243
40	DUM14	-9700	-243	120	DUM94	-1700	-243	200	DUM174	6300	-243
41	DUM15	-9600	-243	121	DUM95	-1600	-243	201	DUM175	6400	-243
42	DUM16	-9500	-243	122	DUM96	-1500	-243	202	DUM176	6500	-243
43	DUM17	-9400	-243	123	DUM97	-1400	-243	203	DUM177	6600	-243
44	DUM18	-9300	-243	124	DUM98	-1300	-243	204	DUM178	6700	-243
45	DUM19	-9200	-243	125	DUM99	-1200	-243	205	DUM179	6800	-243
46	DUM20	-9100	-243	126	DUM100	-1100	-243	206	DUM180	6900	-243
47	DUM21	-9000	-243	127	DUM101	-1000	-243	207	DUM181	7000	-243
48	DUM22	-8900	-243	128	DUM102	-900	-243	208	DUM182	7100	-243
49	DUM23	-8800	-243	129	DUM103	-800	-243	209	DUM183	7200	-243
50	DUM24	-8700	-243	130	DUM104	-700	-243	210	DUM184	7300	-243
51	DUM25	-8600	-243	131	DUM105	-600	-243	211	DUM185	7400	-243
52	DUM26	-8500	-243	132	DUM106	-500	-243	212	DUM186	7500	-243
53	DUM27	-8400	-243	133	DUM107	-400	-243	213	DUM187	7600	-243
54	DUM28	-8300	-243	134	DUM108	-300	-243	214	DUM188	7700	-243
55	DUM29	-8200	-243	135	DUM109	-200	-243	215	DUM189	7800	-243
56	DUM30	-8100	-243	136	DUM110	-100	-243	216	DUM190	7900	-243
57	DUM31	-8000	-243	137	DUM111	0	-243	217	DUM191	8000	-243
58	DUM32	-7900	-243	138	DUM112	100	-243	218	DUM192	8100	-243
59	DUM33	-7800	-243	139	DUM113	200	-243	219	DUM193	8200	-243
60	DUM34	-7700	-243	140	DUM114	300	-243	220	DUM194	8300	-243
61	DUM35	-7600	-243	141	DUM115	400	-243	221	DUM195	8400	-243
62	DUM36	-7500	-243	142	DUM116	500	-243	222	DUM196	8500	-243
63	DUM37	-7400	-243	143	DUM117	600	-243	223	DUM197	8600	-243
64	DUM38	-7300	-243	144	DUM118	700	-243	224	DUM198	8700	-243
65	DUM39	-7200	-243	145	DUM119	800	-243	225	DUM199	8800	-243
66	DUM40	-7100	-243	146	DUM120	900	-243	226	DUM200	8900	-243
67	DUM41	-7000	-243	147	DUM121	1000	-243	227	DUM201	9000	-243
68	DUM42	-6900	-243	148	DUM122	1100	-243	228	DUM202	9100	-243
69	DUM43	-6800	-243	149	DUM123	1200	-243	229	DUM203	9200	-243
70	DUM44	-6700	-243	150	DUM124	1300	-243	230	DUM204	9300	-243
71	DUM45	-6600	-243	151	DUM125	1400	-243	231	DUM205	9400	-243
72	DUM46	-6500	-243	152	DUM126	1500	-243	232	DUM206	9500	-243
73	DUM47	-6400	-243	153	DUM127	1600	-243	233	DUM207	9600	-243
74	DUM48	-6300	-243	154	DUM128	1700	-243	234	DUM208	9700	-243
75	DUM49	-6200	-243	155	DUM129	1800	-243	235	DUM209	9800	-243
76	DUM50	-6100	-243	156	DUM130	1900	-243	236	DUM210	9900	-243
77	DUM51	-6000	-243	157	DUM131	2000	-243	237	DUM211	10000	-243
78	DUM52	-5900	-243	158	DUM132	2100	-243	238	DUM212	10100	-243
79	DUM53	-5800	-243	159	DUM133	2200	-243	239	DUM213	10200	-243
80	DUM54	-5700	-243	160	DUM134	2300	-243	240	DUM214	10300	-243

Pad #	Pad Name	Pad Coordinate	
		X	Y
241	DUM215	10400	-243
242	DUM216	10500	-243
243	DUM217	10600	-243
244	DUM218	10700	-243
245	DUM219	10800	-243
246	DUM220	10900	-243
247	PATH2R	11000	-243
248	SEL1R	11283	-262
249	SEL0R	11373	-262
250	MODE0R	11463	-262
251	MODE1R	11553	-262
252	GND	11643	-262
253	GND	11733	-262
254	VCC	11643	-208
255	VCC	11733	-208
256	VGL	11643	-156
257	VGL	11733	-156
258	VGH	11643	-104
259	VGH	11733	-104
260	STVDR	11643	-52
261	STVDR	11733	-52
262	PATH1R	11643	0
263	PATH1R	11733	0
264	CLKR	11643	52
265	CLKR	11733	52
266	UDR	11643	104
267	UDR	11733	104
268	OE3R	11643	156
269	OE3R	11733	156
270	OE2R	11643	208
271	OE2R	11733	208
272	OE1R	11643	262
273	OE1R	11733	262
274	F_CTRLR	11553	262
275	F_CTRLR	11463	262
276	XONR	11373	262
277	XONR	11283	262
278	PATH3R	10836	235.5
279	OUT[0]	10800	235.5
280	OUT[1]	10782	235.5
281	OUT[2]	10764	235.5
282	OUT[3]	10746	235.5
283	OUT[4]	10728	235.5
284	OUT[5]	10710	235.5
285	OUT[6]	10692	235.5
286	OUT[7]	10674	235.5
287	OUT[8]	10656	235.5
288	OUT[9]	10638	235.5
289	OUT[10]	10620	235.5
290	OUT[11]	10602	235.5
291	OUT[12]	10584	235.5
292	OUT[13]	10566	235.5
293	OUT[14]	10548	235.5
294	OUT[15]	10530	235.5
295	OUT[16]	10512	235.5
296	OUT[17]	10494	235.5
297	OUT[18]	10476	235.5
298	OUT[19]	10458	235.5
299	OUT[20]	10440	235.5
300	OUT[21]	10422	235.5
301	OUT[22]	10404	235.5
302	OUT[23]	10386	235.5
303	OUT[24]	10368	235.5
304	OUT[25]	10350	235.5
305	OUT[26]	10332	235.5
306	OUT[27]	10314	235.5
307	OUT[28]	10296	235.5
308	OUT[29]	10278	235.5
309	OUT[30]	10260	235.5
310	OUT[31]	10242	235.5
311	OUT[32]	10224	235.5
312	OUT[33]	10206	235.5
313	OUT[34]	10188	235.5
314	OUT[35]	10170	235.5
315	OUT[36]	10152	235.5
316	OUT[37]	10134	235.5
317	OUT[38]	10116	235.5
318	OUT[39]	10098	235.5
319	OUT[40]	10080	235.5
320	OUT[41]	10062	235.5

Pad #	Pad Name	Pad Coordinate	
		X	Y
321	OUT[42]	10044	235.5
322	OUT[43]	10026	235.5
323	OUT[44]	10008	235.5
324	OUT[45]	9990	235.5
325	OUT[46]	9972	235.5
326	OUT[47]	9954	235.5
327	OUT[48]	9936	235.5
328	OUT[49]	9918	235.5
329	OUT[50]	9900	235.5
330	OUT[51]	9882	235.5
331	OUT[52]	9864	235.5
332	OUT[53]	9846	235.5
333	OUT[54]	9828	235.5
334	OUT[55]	9810	235.5
335	OUT[56]	9792	235.5
336	OUT[57]	9774	235.5
337	OUT[58]	9756	235.5
338	OUT[59]	9738	235.5
339	OUT[60]	9720	235.5
340	OUT[61]	9702	235.5
341	OUT[62]	9684	235.5
342	OUT[63]	9666	235.5
343	OUT[64]	9648	235.5
344	OUT[65]	9630	235.5
345	OUT[66]	9612	235.5
346	OUT[67]	9594	235.5
347	OUT[68]	9576	235.5
348	OUT[69]	9558	235.5
349	OUT[70]	9540	235.5
350	OUT[71]	9522	235.5
351	OUT[72]	9504	235.5
352	OUT[73]	9486	235.5
353	OUT[74]	9468	235.5
354	OUT[75]	9450	235.5
355	OUT[76]	9432	235.5
356	OUT[77]	9414	235.5
357	OUT[78]	9396	235.5
358	OUT[79]	9378	235.5
359	OUT[80]	9360	235.5
360	OUT[81]	9342	235.5
361	OUT[82]	9324	235.5
362	OUT[83]	9306	235.5
363	OUT[84]	9288	235.5
364	OUT[85]	9270	235.5
365	OUT[86]	9252	235.5
366	OUT[87]	9234	235.5
367	OUT[88]	9216	235.5
368	OUT[89]	9198	235.5
369	OUT[90]	9180	235.5
370	OUT[91]	9162	235.5
371	OUT[92]	9144	235.5
372	OUT[93]	9126	235.5
373	OUT[94]	9108	235.5
374	OUT[95]	9090	235.5
375	OUT[96]	9072	235.5
376	OUT[97]	9054	235.5
377	OUT[98]	9036	235.5
378	OUT[99]	9018	235.5
379	OUT[100]	9000	235.5
380	OUT[101]	8982	235.5
381	OUT[102]	8964	235.5
382	OUT[103]	8946	235.5
383	OUT[104]	8928	235.5
384	OUT[105]	8910	235.5
385	OUT[106]	8892	235.5
386	OUT[107]	8874	235.5
387	OUT[108]	8856	235.5
388	OUT[109]	8838	235.5
389	OUT[110]	8820	235.5
390	OUT[111]	8802	235.5
391	OUT[112]	8784	235.5
392	OUT[113]	8766	235.5
393	OUT[114]	8748	235.5
394	OUT[115]	8730	235.5
395	OUT[116]	8712	235.5
396	OUT[117]	8694	235.5
397	OUT[118]	8676	235.5
398	OUT[119]	8658	235.5
399	OUT[120]	8640	235.5
400	OUT[121]	8622	235.5

Pad #	Pad Name	Pad Coordinate	
		X	Y
401	OUT[122]	8604	235.5
402	OUT[123]	8586	235.5
403	OUT[124]	8568	235.5
404	OUT[125]	8550	235.5
405	OUT[126]	8532	235.5
406	OUT[127]	8514	235.5
407	OUT[128]	8496	235.5
408	OUT[129]	8478	235.5
409	OUT[130]	8460	235.5
410	OUT[131]	8442	235.5
411	OUT[132]	8424	235.5
412	OUT[133]	8406	235.5
413	OUT[134]	8388	235.5
414	OUT[135]	8370	235.5
415	OUT[136]	8352	235.5
416	OUT[137]	8334	235.5
417	OUT[138]	8316	235.5
418	OUT[139]	8298	235.5
419	OUT[140]	8280	235.5
420	OUT[141]	8262	235.5
421	OUT[142]	8244	235.5
422	OUT[143]	8226	235.5
423	OUT[144]	8208	235.5
424	OUT[145]	8190	235.5
425	OUT[146]	8172	235.5
426	OUT[147]	8154	235.5
427	OUT[148]	8136	235.5
428	OUT[149]	8118	235.5
429	OUT[150]	8100	235.5
430	OUT[151]	8082	235.5
431	OUT[152]	8064	235.5
432	OUT[153]	8046	235.5
433	OUT[154]	8028	235.5
434	OUT[155]	8010	235.5
435	OUT[156]	7992	235.5
436	OUT[157]	7974	235.5
437	OUT[158]	7956	235.5
438	OUT[159]	7938	235.5
439	OUT[160]	7920	235.5
440	OUT[161]	7902	235.5
441	OUT[162]	7884	235.5
442	OUT[163]	7866	235.5
443	OUT[164]	7848	235.5
444	OUT[165]	7830	235.5
445	OUT[166]	7812	235.5
446	OUT[167]	7794	235.5
447	OUT[168]	7776	235.5
448	OUT[169]	7758	235.5
449	OUT[170]	7740	235.5
450	OUT[171]	7722	235.5
451	OUT[172]	7704	235.5
452	OUT[173]	7686	235.5
453	OUT[174]	7668	235.5
454	OUT[175]	7650	235.5
455	OUT[176]	7632	235.5
456	OUT[177]	7614	235.5
457	OUT[178]	7596	235.5
458	OUT[179]	7578	235.5
459	OUT[180]	7560	235.5
460	OUT[181]	7542	235.5
461	OUT[182]	7524	235.5
462	OUT[183]	7506	235.5
463	OUT[184]	7488	235.5
464	OUT[185]	7470	235.5
465	OUT[186]	7452	235.5
466	OUT[187]	7434	235.5
467	OUT[188]	7416	235.5
468	OUT[189]	7398	235.5
469	OUT[190]	7380	235.5
470	OUT[191]	7362	235.5
471	OUT[192]	7344	235.5
472	OUT[193]	7326	235.5
473	OUT[194]	7308	235.5
474	OUT[195]	7290	235.5
475	OUT[196]	7272	235.5
476	OUT[197]	7254	235.5
477	OUT[198]	7236	235.5
478	OUT[199]	7218	235.5
479	OUT[200]	7200	235.5
480	OUT[201]	7182	235.5

Pad #	Pad Name	Pad Coordinate	
		X	Y
1441	OUT[1162]	-10116	235.5
1442	OUT[1163]	-10134	125.5
1443	OUT[1164]	-10152	235.5
1444	OUT[1165]	-10170	125.5
1445	OUT[1166]	-10188	235.5
1446	OUT[1167]	-10206	125.5
1447	OUT[1168]	-10224	235.5
1448	OUT[1169]	-10242	125.5
1449	OUT[1170]	-10260	235.5
1450	OUT[1171]	-10278	125.5
1451	OUT[1172]	-10296	235.5
1452	OUT[1173]	-10314	125.5
1453	OUT[1174]	-10332	235.5
1454	OUT[1175]	-10350	125.5
1455	OUT[1176]	-10368	235.5
1456	OUT[1177]	-10386	125.5
1457	OUT[1178]	-10404	235.5
1458	OUT[1179]	-10422	125.5
1459	OUT[1180]	-10440	235.5
1460	OUT[1181]	-10458	125.5
1461	OUT[1182]	-10476	235.5
1462	OUT[1183]	-10494	125.5
1463	OUT[1184]	-10512	235.5
1464	OUT[1185]	-10530	125.5
1465	OUT[1186]	-10548	235.5
1466	OUT[1187]	-10566	125.5
1467	OUT[1188]	-10584	235.5
1468	OUT[1189]	-10602	125.5
1469	OUT[1190]	-10620	235.5
1470	OUT[1191]	-10638	125.5
1471	OUT[1192]	-10656	235.5
1472	OUT[1193]	-10674	125.5
1473	OUT[1194]	-10692	235.5
1474	OUT[1195]	-10710	125.5
1475	OUT[1196]	-10728	235.5
1476	OUT[1197]	-10746	125.5
1477	OUT[1198]	-10764	235.5
1478	OUT[1199]	-10782	125.5
1479	OUT[1200]	-10800	235.5
1480	OUT[1201]	-10818	125.5
1481	PATN3L	-10836	235.5
1482	XONL	-11283	262
1483	XONR	-11373	262
1484	F_CTRL	-11463	262
1485	F_CTRL	-11553	262
1486	AL_MARK_L	-11101.5	220.5
1487	AL_MARK_R	11101.5	220.5

9. DEFINITIONS

9.1 Data Sheet Status

Preliminary Data Sheet	This data sheet contains preliminary data; supplementary data may be published later.
Data Sheet	This data sheet contains final product specifications.

Contents in the document are subject to change without notice.

9.2 Life Support Application

These products are not designed for use in life support appliances, devices, or systems where malfunction of these products can reasonably be expected to result in personal injury. fitipower customers using or selling these products for use in such applications do so at their own risk and agree to fully indemnify fitipower for any damages resulting from such improper use or sale.

10 REVISION HISTORY

Revision	Content	Page	Date
1.0	New Issue		2012/11/07
1.1	(1) Add VCC Rating = 1.7~2.3V application (2) Modify ELECTRICAL SPECIFICATION (VGL Operating Range) (3) Modify DC Characteristics (Pull high / low resistance) (4) Modify AC Characteristics (t_{CLK} , t_{WOE} , t_{PD1} , t_{PD2} , t_{PD3} , t_{PD4})	2,12,13,14	2013/05/30