

**Eureka** Microelectronics, Inc.

# EK7010TCC-2101

240 Output Segment/  
Common LCD Driver



3F, No. 7, Industrial East Road 9, Science-Based  
Industrial Park, Hsin-Chu, Taiwan, R.O.C  
Tel: 886-3-5799255  
Fax: 886-3-5799253  
<http://www.eureka.com.tw>



## 240 Output Segment/Common LCD Driver

### Description

The EK7010 is a 240 output segment/common LCD driver adaptable to drive a large scale dot matrix panel. It uses the Tape Carrier Package(TCP) to greatly reduce the size of the LCD module. EK7010 consumes very little power. Large LCD panels can be assembled by cascading EK7010s. In Segment Mode, the input data can be either 4-bit parallel or 8-bit parallel, selected by the Mode Select pin (MD).

### Features

- CMOS process
- Logic power supply : 2.5V to 5.5V
- Low power consumption
- 240 LCD display output
- Supply voltage for LCD driver :15 to 40V
- Package : TCP, COG available

### Features in Segment mode

- Shift clock frequency : 20MHz max. at  $V_{DD}=5V$
- 4bit/8bit parallel input
- Automatic transfer of enable signal
- Automatic counting in the chip select mode. The internal clock is stopped by automatically counting 240 of input data.

### Features in Common mode

- Shift clock frequency : 4MHz max. at  $V_{DD}=5V$
- Built-in 240-bit bidirectional shift register
- Single mode (240-bit shift register) or Dual Mode (two 120-bit shift registers) with these options:
  1.  $Y_1 \rightarrow Y_{240}$  Single mode
  2.  $Y_{240} \rightarrow Y_1$  Single mode
  3.  $Y_1 \rightarrow Y_{120}, Y_{121} \rightarrow Y_{240}$  Dual mode
  4.  $Y_{240} \rightarrow Y_{121}, Y_{120} \rightarrow Y_1$  Dual mode

### Block Diagram

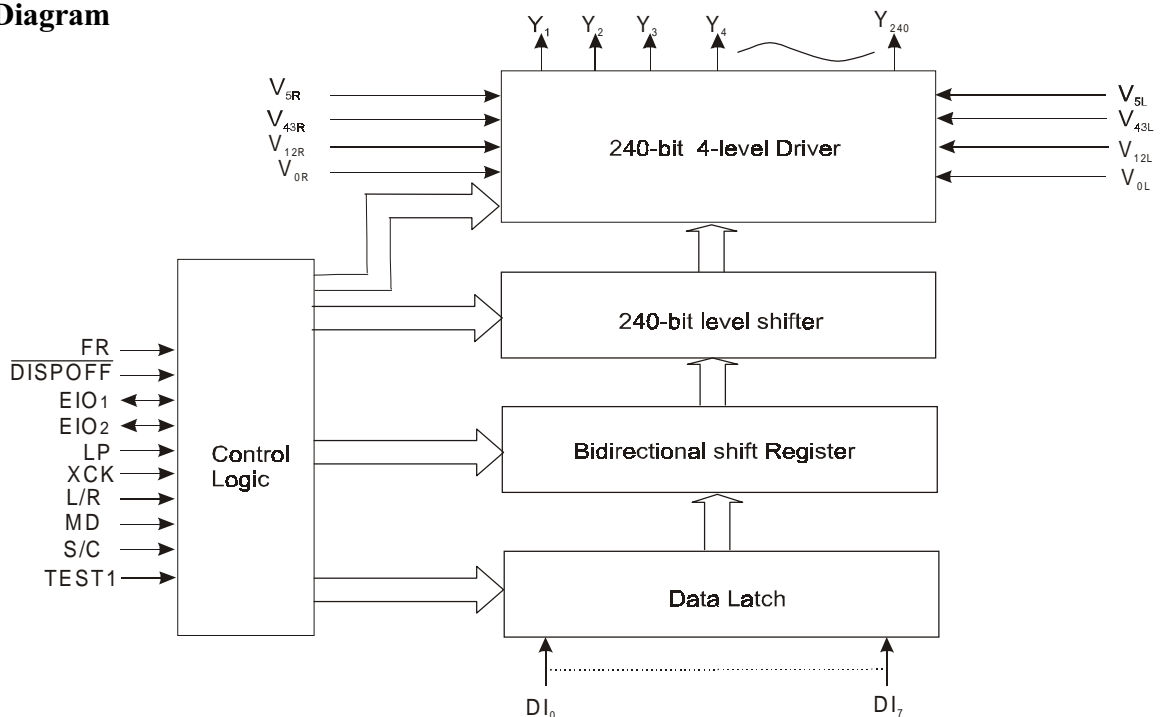

Fig.1  
1

## Pin Configuration

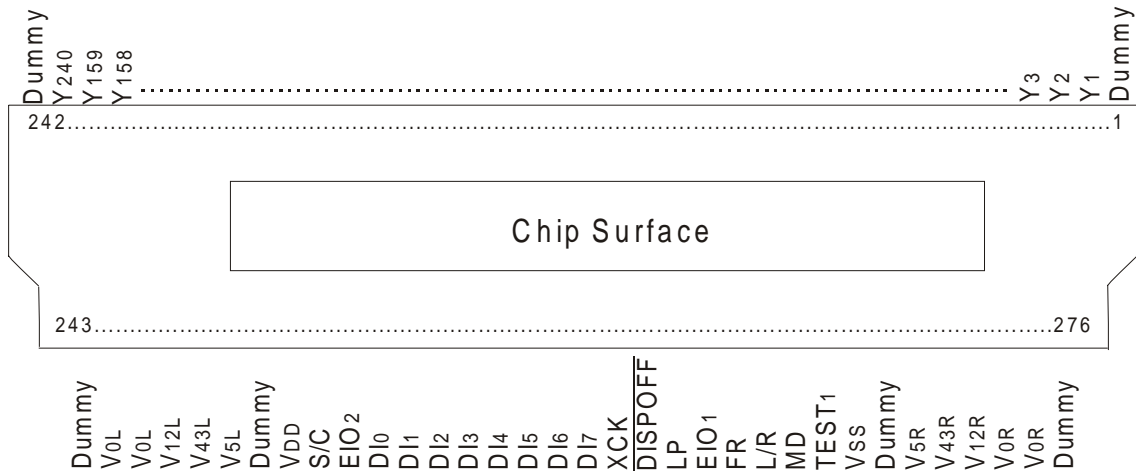

Fig.2

## Pin Designations

Pin No.	Symbol	I/O	Designation
2 to 241	Y1-Y240	O	LCD output
244, 245, 274, 275	V0L, V0R	-	Power supply for LCD driver level
246, 273	V12L, V12R	-	Power supply for LCD driver level
247, 272	V43L, V43R	-	Power supply for LCD driver level
248, 271	V5L, V5R	-	Power supply for LCD driver level
269	V <sub>SS</sub>	-	Ground
250	V <sub>DD</sub>	-	Power supply for logic circuit(+2.5 to +5.5V)
251	S/C	I	Segment mode/common mode selection
252	EIO2	I/O	Input/output for chip select or data of shift register
253 to 259	DI0-DI6	I	Input of display data in segment mode
260	DI7	I	Input of display data for Segment mode, or Dual mode data input for common mode.
261	XCK	I	Display data shift clock input in segment mode
262	$\overline{\text{DISPOFF}}$	I	Control pin input to deselect output level
263	LP	I	Latch pulse input in segment mode Shift clock input for shift register in common mode
264	EIO1	I/O	Input/output for chip select or data of shift register
265	FR	I	AC-converting signal input for LCD driver waveform
266	L/R	I	Display data shift direction selection
267	MD	I	Mode selection
268	TEST1	I	Test mode selection
1, 242,243, 249, 270, 276	Dummy	-	Dummy PADS

Tab.1

## Input/Output Circuit

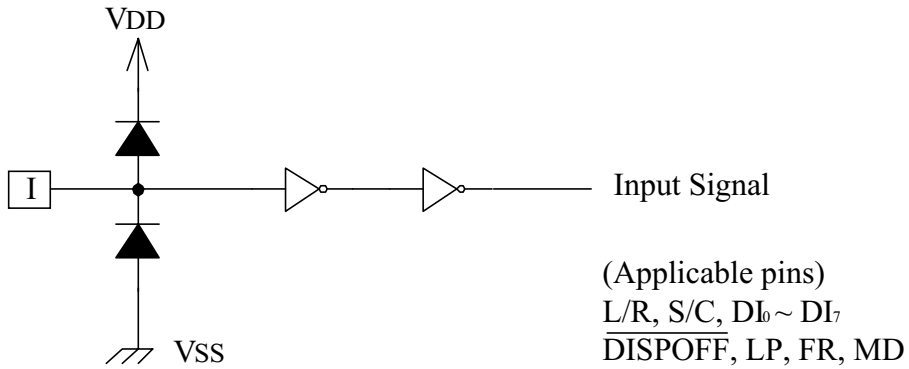

Fig.3 Input Circuit(1)

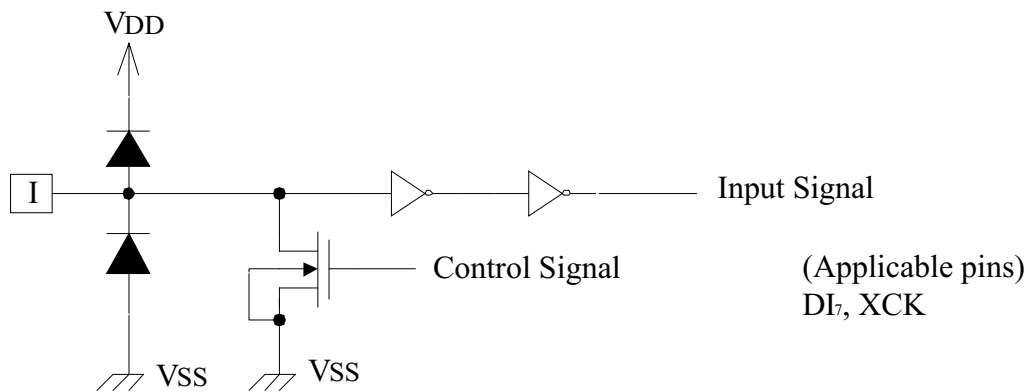

Fig.4 Input Circuit(2)

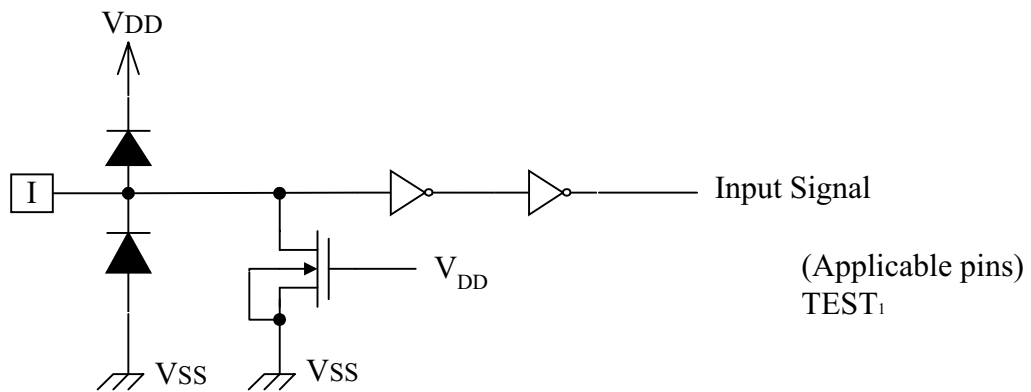

Fig.5 Input Circuit(3)

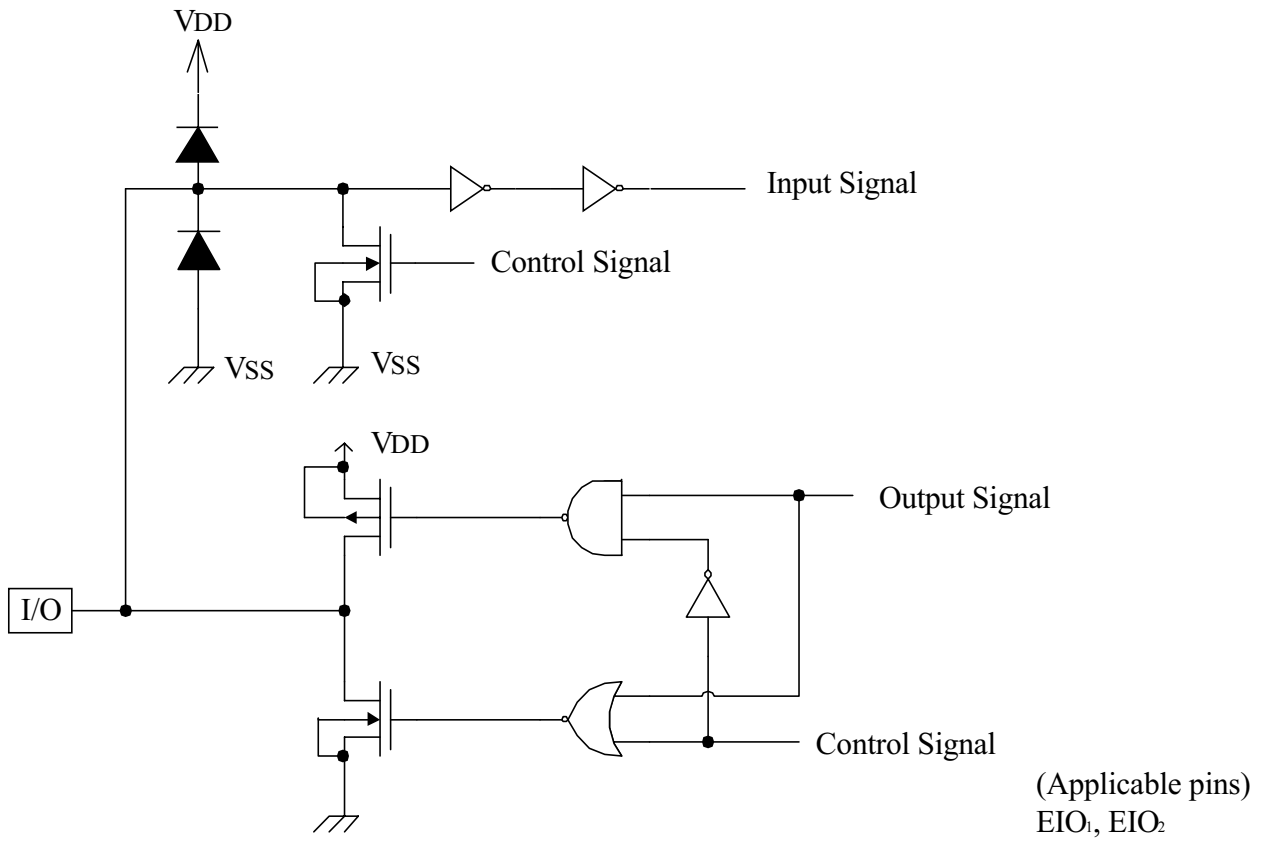

Fig.6 Input/Output Circuit

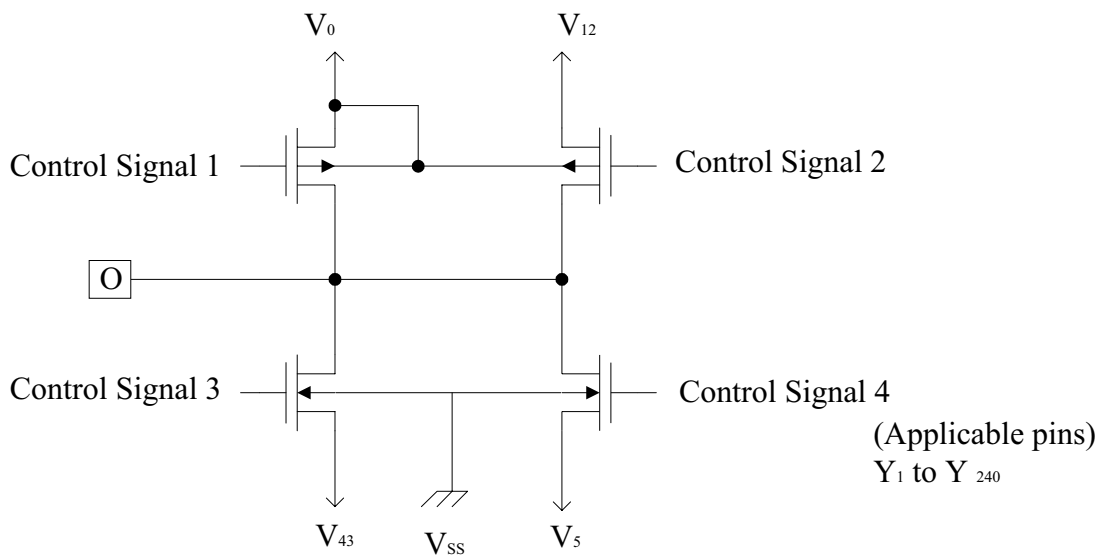

Fig.7 LCD Driver Output Circuit

## Pin Functions (Segment mode)

Symbol	Function
$V_{DD}$	Logic circuit power supply +2.5 to +5.5 V
$V_{SS}$	Ground pin
$V_{0R}, V_{0L}$ $V_{12R}, V_{12L}$ $V_{43R}, V_{43L}$ $V_{5R}, V_{5L}$	Power supply for LCD driver voltage level <ul style="list-style-type: none"> <li>● Normally, the bias voltage used is set by a resistor divider.</li> <li>● Ensure that voltages are set such that <math>V_{SS} &lt; V_5 &lt; V_{43} &lt; V_{12} &lt; V_0</math>.</li> <li>● <math>V_{iR}</math> and <math>V_{iL}</math> (<math>i=0, 12, 43, 5</math>) should be externally connected to reduce the difference between the waveforms of the output pins <math>Y_1 \sim Y_{240}</math>.</li> </ul>
DI0~DI7	Input for display data <ul style="list-style-type: none"> <li>● In 4-bit parallel input mode, input data into the 4 pins DI0~DI3. Connect DI4~DI7 to <math>V_{SS}</math> or <math>V_{DD}</math>.</li> <li>● In 8-bit parallel input mode, input data into the 8 pins DI0~DI7.</li> </ul>
XCK	Input clock pin for displaying data <ul style="list-style-type: none"> <li>● Data is read on the falling edge of the clock pulse.</li> </ul>
LP	Latch pulse input for displaying data <ul style="list-style-type: none"> <li>● Data is latched on the falling edge of the clock pulse.</li> </ul>
L/R	Direction selection for reading display data <ul style="list-style-type: none"> <li>● When set to <math>V_{SS}</math>, data is read sequentially from <math>Y_{240}</math> to <math>Y_1</math>.</li> <li>● When set to <math>V_{DD}</math>, data is read sequentially from <math>Y_1</math> to <math>Y_{240}</math>.</li> </ul>
$\overline{DISPOFF}$	Control input to deselect output level <ul style="list-style-type: none"> <li>● The input signal is level-shifted from logic voltage level to LC drive voltage level and control LCD drive circuit.</li> <li>● When set to <math>V_{SS}</math> level "L", the LCD driver output pins (<math>Y_1 \sim Y_{240}</math>) are set to level <math>V_5</math>.</li> <li>● While set to "L", the contents of the line latch are cleared, but read the display data in the data latch regardless of condition of <math>\overline{DISPOFF}</math>. When the <math>\overline{DISPOFF}</math> function is cancelled, the driver outputs deselect level (<math>V_{12}</math> or <math>V_{43}</math>), then outputs the contents of the data latch on the next falling edge of the LP. At that time, if <math>\overline{DISPOFF}</math> removal time does not meet the conditions shown in Tab.15, it can not output the reading data correctly.</li> </ul>
FR	AC signal for LCD driver output level <ul style="list-style-type: none"> <li>● The input signal is level-shifted from logic voltage level to LCD drive voltage level, and controls LCD drive circuit.</li> <li>● Normally, inputs a frame inversion signal.</li> <li>● The LCD driver output voltage level of output pin can be setted using the line latch output signal and the FR signal.</li> <li>● Truth table is shown on Tab.6 &amp; Tab.7.</li> </ul>

Tab.2

## Pin Functions

### (Segment mode)

Symbol	Function
MD	Mode selection <ul style="list-style-type: none"><li>● When set to <math>V_{DD}</math> level "H", 4-bit parallel input mode is selected.</li><li>● When set to <math>V_{SS}</math> level "L", 8-bit parallel input mode is selected.</li><li>● The relationship between the display data and driver output pins is shown on Tab.8 &amp; Tab.9.</li></ul>
S/C	Segment mode/common mode selection pin <ul style="list-style-type: none"><li>● When set to <math>V_{DD}</math>, segment input mode is set.</li></ul>
EIO1 EIO2	Input/Output for chip selection <ul style="list-style-type: none"><li>● When L/R input is at <math>V_{SS}</math> level "L", EIO<sub>1</sub> is set for output, and EIO<sub>2</sub> is set for input.</li><li>● When L/R input is at <math>V_{DD}</math> level "H", EIO<sub>1</sub> is set for input, and EIO<sub>2</sub> is set for output.</li><li>● During output, set to "H" while LP*<math>\overline{XCK}</math> is "H" and after 240-bit data have been read, set to "L" for one cycle (from falling edge of XCK to next falling edge of XCK), after which it returns to "H".</li><li>● During input, after the LP signal is input, the chip is selected while EI is set to "L". After 240-bits of data have been read, the chip is deselected.</li></ul>
TEST1	Test mode selection <ul style="list-style-type: none"><li>● During normal operation, tie to <math>V_{SS}</math> level "L".</li></ul>
$Y_1$ - $Y_{240}$	LCD driver output <ul style="list-style-type: none"><li>● Corresponding directly to each bit of the data latch, one level (<math>V_0</math>, <math>V_{12}</math>, <math>V_{43}</math>, or <math>V_{\xi}</math>) is selected for output.</li><li>● Truth table values is shown on Tab.6 &amp; Tab.7 .</li></ul>

Tab.3



## Pin Functions (Common mode)

Symbol	Function
$V_{DD}$	Logic circuit power supply pin connects to +2.5 to +5.5 V.
$V_{SS}$	Ground pin.
$V_{0R}, V_{0L}$ $V_{12R}, V_{12L}$ $V_{43R}, V_{43L}$ $V_{5R}, V_{5L}$	Power supply pin for LCD driver voltage bias <ul style="list-style-type: none"> <li>● Normally, the bias voltage is set by a resistor divider</li> <li>● Ensure that voltages are set such that (<math>V_{SS} \leq V_5 &lt; V_{43} &lt; V_{12} &lt; V_0</math>)</li> <li>● <math>V_{iR}</math> and <math>V_{iL}</math> (i=0, 12, 43, 5) should be externally connected to reduce the difference between the waveforms of the output pins <math>Y_1 \sim Y_{240}</math>.</li> </ul>
$EIO_1$	Bidirectional shift register input/output. <ul style="list-style-type: none"> <li>● Output when L/R is set at <math>V_{SS}</math> level "L", input when L/R is at <math>V_{DD}</math> level "H".</li> <li>● When <math>EIO_1</math> is used as input pin, it will be pull-down.</li> <li>● When <math>EIO_1</math> is used as output pin, it not be pull-down.</li> </ul>
$EIO_2$	Bidirectional shift register input/output. <ul style="list-style-type: none"> <li>● Input when L/R is set at <math>V_{SS}</math> level "L". output when L/R is at <math>V_{DD}</math> level "H".</li> <li>● When <math>EIO_2</math> is used as input, it will be pull-down.</li> <li>● When <math>EIO_2</math> is used as output, it will not be pull-down.</li> </ul>
LP	Bidirectional shift register clock pulse input <ul style="list-style-type: none"> <li>● Data is shifted on the falling edge of the clock pulse.</li> </ul>
L/R	Bidirectional shift register shift direction selection <ul style="list-style-type: none"> <li>● When set to <math>V_{SS}</math>, data is shifted from <math>Y_{240}</math> to <math>Y_1</math>.</li> <li>● When set to <math>V_{DD}</math>, data is shifted from <math>Y_1</math> to <math>Y_{240}</math>.</li> </ul>
$\overline{DISPOFF}$	Control input pin to deselect output level <ul style="list-style-type: none"> <li>● The input signal is level-shifted from logic voltage level to LCD drive voltage level, and controls LCD drive circuit.</li> <li>● When set to "L", the LCD driver output pins (<math>Y_1 \sim Y_{240}</math>) are set to level <math>V_5</math>.</li> <li>● While set to "L", the contents of the shift register are cleared. When the <math>\overline{DISPOFF}</math> function is canceled, the driver outputs deselect level (<math>V_{12}</math> or <math>V_{43}</math>), and the shift data is read on the falling edge of the LP. At that time, if the <math>\overline{DISPOFF}</math> removal time does not meet the conditions shown in Fig.16, then the shift data is not read correctly.</li> </ul>
FR	AC signal input for LCD driver output level <ul style="list-style-type: none"> <li>● The input signal is level-shifted from logic voltage level to LCD driver voltage level, and controls LCD drive circuit.</li> <li>● The LCD driver output voltage level can be set by using the shift register output signal and the FR signal.</li> <li>● Truth table is shown on Tab.6 &amp; Tab.7.</li> </ul>

Tab.4

## Pin Functions (Common mode)

Symbol	Function
MD	Mode selection ● When set to $V_{SS}$ level "L", Single Mode operation is selected, when set to $V_{DD}$ level "H", Dual Mode operation is selected.
DI <sub>7</sub>	Dual Mode data input ● According to the data shift direction of the data shift register, data can be input starting from the 121th bit ● When the chip is used as Dual Mode, DI <sub>7</sub> will be pull-down. ● When the chip is used as Single Mode, DI <sub>7</sub> will not be pull-down.
S/C	Segment mode/common mode selection ● When set to $V_{SS}$ level "L", Common Mode is setted.
DI <sub>0</sub> ~DI <sub>6</sub>	Not used ● Connect DI <sub>0</sub> ~DI <sub>6</sub> to $V_{SS}$ or $V_{DD}$ . Avoiding floating.
XCK	Not used ● XCK is pull-down in common mode, so connect them to $V_{SS}$ or open.
TEST <sub>1</sub>	Test mode select ● During normal operation, tie to $V_{SS}$ level "L".
Y <sub>1</sub> ~Y <sub>240</sub>	LCD driver output ● Corresponding directly to each bit of the shift register, one level ( $V_0$ , $V_{12}$ , $V_{43}$ , or $V_5$ ) is selected. ● Truth table is shown on Tab.6 & Tab.7.

Tab.5

## Functional Operations

### Truth Table

#### (Segment Mode)

FR	Latch Data	$\overline{\text{DISPOFF}}$	Driver Output Voltage Level( $Y_1$ - $Y_{240}$ )
L	L	H	V <sub>43</sub>
L	H	H	V <sub>5</sub>
H	L	H	V <sub>12</sub>
H	H	H	V <sub>0</sub>
X	X	L	V <sub>5</sub>

Here,  $V_{SS} \leq V_5 < V_{43} < V_{12} < V_0$ , H:V<sub>DD</sub> (+2.5 to +5.5V), L:V<sub>SS</sub>(0 V)

X:Don't care

Tab.6

#### (Common Mode)

FR	Latch Data	$\overline{\text{DISPOFF}}$	Driver Output Voltage Level( $Y_1$ - $Y_{240}$ )
L	L	H	V <sub>43</sub>
L	H	H	V <sub>0</sub>
H	L	H	V <sub>12</sub>
H	H	H	V <sub>5</sub>
X	X	L	V <sub>5</sub>

Here,  $V_{SS} \leq V_5 < V_{43} < V_{12} < V_0$ , H:V<sub>DD</sub> (+2.5 to +5.5V), L:V<sub>SS</sub>(0 V)

X:Don't care

Tab.7

Note:There have two kinds of power supply (logic level voltage, LCD drive voltage) for LCD driver.

Supply proper voltage according to each power pin specification.

“Don't care” means that it should be connected to “H” or “L”. Do not leave them open.

## Relationship between the Display Data and Driver Output pins

(Segment Mode)

(a)8-bit Parallel Mode

MD	L/R	EIO1	EIO2	Data Input	Figure of Clock						
					30 clock	29 clock	28 clock	.....	3 clock	2 clock	1 clock
L	L	Output	Input	DI0	Y1	Y9	Y17	.....	Y217	Y225	Y233
				DI1	Y2	Y10	Y18	.....	Y218	Y226	Y234
				DI2	Y3	Y11	Y19	.....	Y219	Y227	Y235
				DI3	Y4	Y12	Y20	.....	Y220	Y228	Y236
				DI4	Y5	Y13	Y21	.....	Y221	Y229	Y237
				DI5	Y6	Y14	Y22	.....	Y222	Y230	Y238
				DI6	Y7	Y15	Y23	.....	Y223	Y231	Y239
				DI7	Y8	Y16	Y24	.....	Y224	Y232	Y240
L	H	Input	Output	DI0	Y240	Y232	Y224	.....	Y24	Y16	Y8
				DI1	Y239	Y231	Y223	.....	Y23	Y15	Y7
				DI2	Y238	Y230	Y222	.....	Y22	Y14	Y6
				DI3	Y237	Y229	Y221	.....	Y21	Y13	Y5
				DI4	Y236	Y228	Y220	.....	Y20	Y12	Y4
				DI5	Y235	Y227	Y219	.....	Y19	Y11	Y3
				DI6	Y234	Y226	Y218	.....	Y18	Y10	Y2
				DI7	Y233	Y225	Y217	.....	Y17	Y9	Y1

Tab.8

(b)4-bit Parallel Mode

MD	L/R	EIO1	EIO2	Data Input	Figure of Clock						
					60 clock	59 clock	58 clock	.....	3 clock	2 clock	1 clock
H	L	Output	Input	DI0	Y1	Y5	Y9	.....	Y229	Y233	Y237
				DI1	Y2	Y6	Y10	.....	Y230	Y234	Y238
				DI2	Y3	Y7	Y11	.....	Y231	Y235	Y239
				DI3	Y4	Y8	Y12	.....	Y232	Y236	Y240
H	H	Input	Output	DI0	Y240	Y236	Y232	.....	Y12	Y8	Y4
				DI1	Y239	Y235	Y231	.....	Y11	Y7	Y3
				DI2	Y238	Y234	Y230	.....	Y10	Y6	Y2
				DI3	Y237	Y233	Y229	.....	Y9	Y5	Y1

Tab.9

**(Common Mode)**

MD	L/R	Data Transfer Direction	EIO1	EIO2	DI7
L (Single)	L(shift to left)	$Y_{240} \rightarrow Y_1$	Output	Input	X
	H(shift to right)	$Y_1 \rightarrow Y_{240}$	Input	Output	X
H (Dual)	L(shift to left)	$Y_{240} \rightarrow Y_{121}$ $Y_{120} \rightarrow Y_1$	Output	Input	Input
	H(shift to right)	$Y_1 \rightarrow Y_{120}$ $Y_{121} \rightarrow Y_{240}$	Input	Output	Input

Tab.10

L:  $V_{SS}$ (0 V), H:  $V_{DD}$  (+2.5V to +5.5V), X: Don't Care

Note: "Don't care" means that it should be connected to "H" or "L". Do not leave them open.

## Connection Examples of Plural Segment Drives

(a) Case of L/R="L"

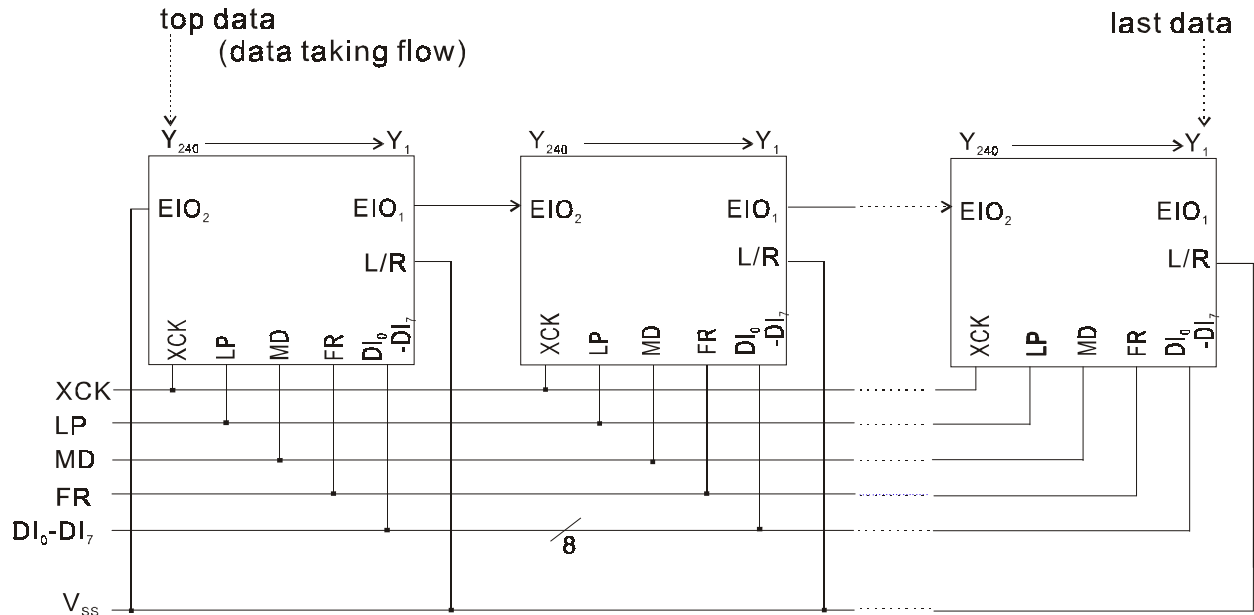

Fig.8

(b) Case of L/R="H"

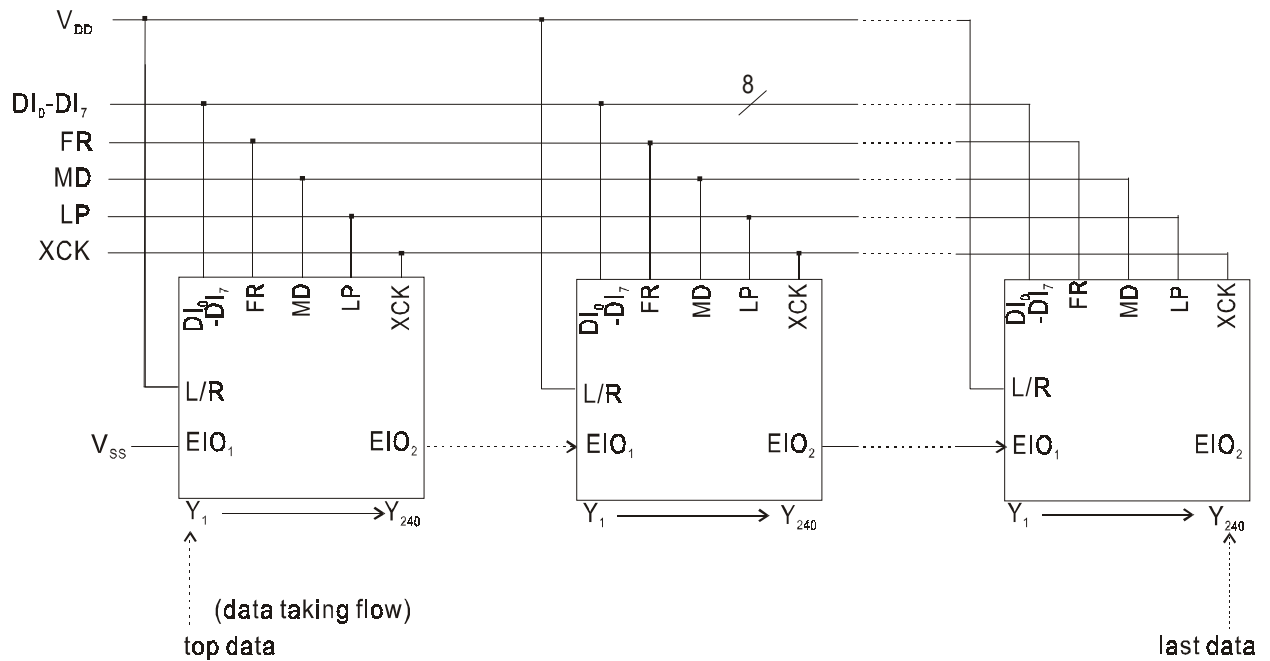

Fig.9

## Timing Chart of 4-Device cascade Connection of Segment Drivers

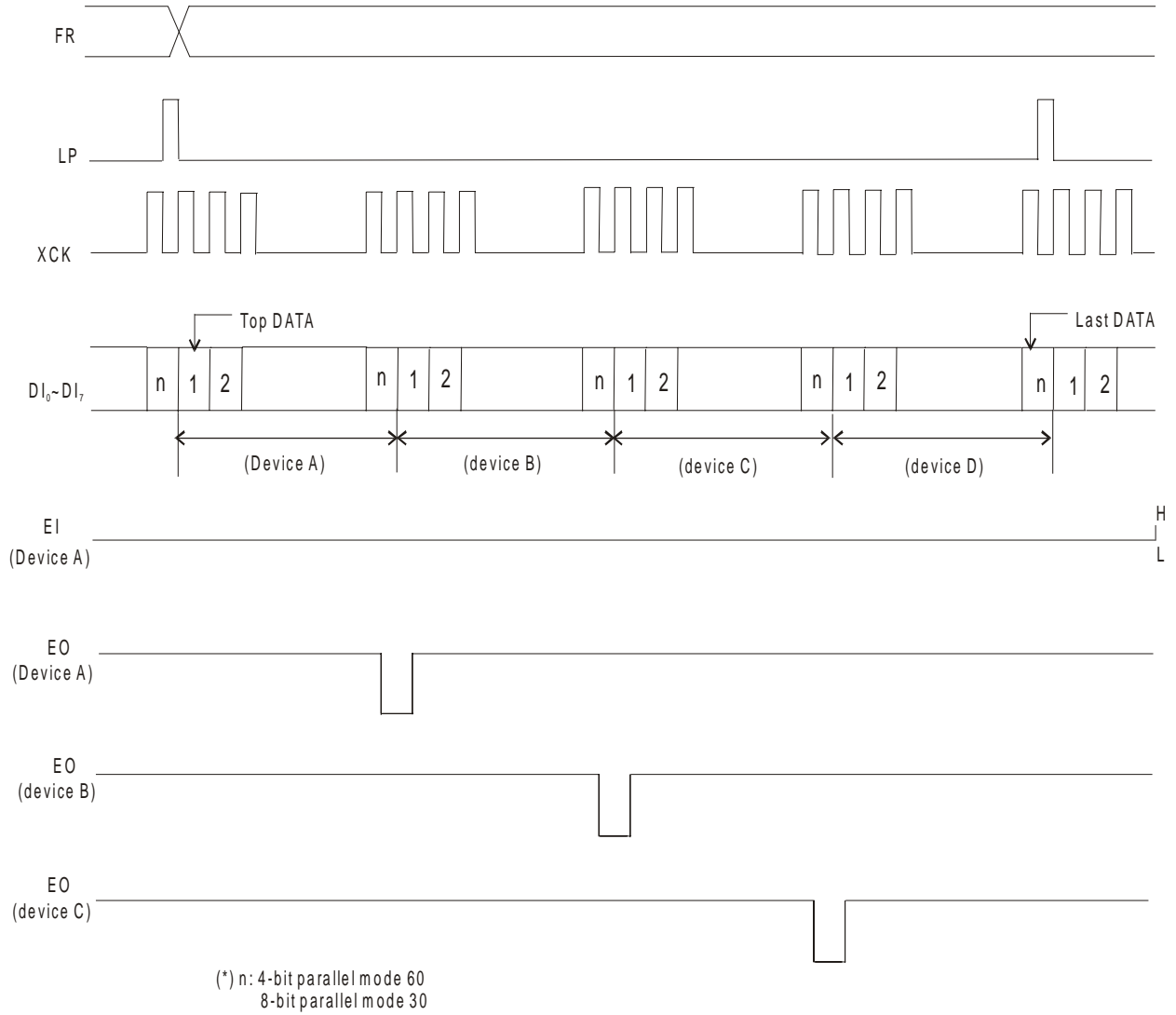

Fig.10



## Connection Examples for Plural Common Drivers

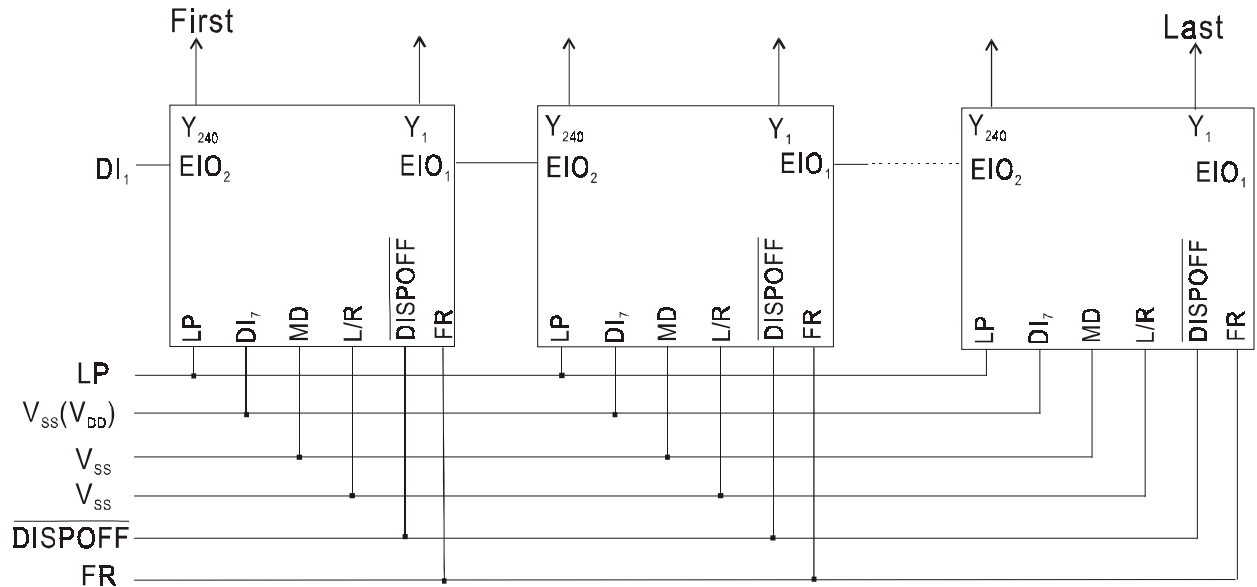

Fig.11 Single Mode (Shifting toward left)

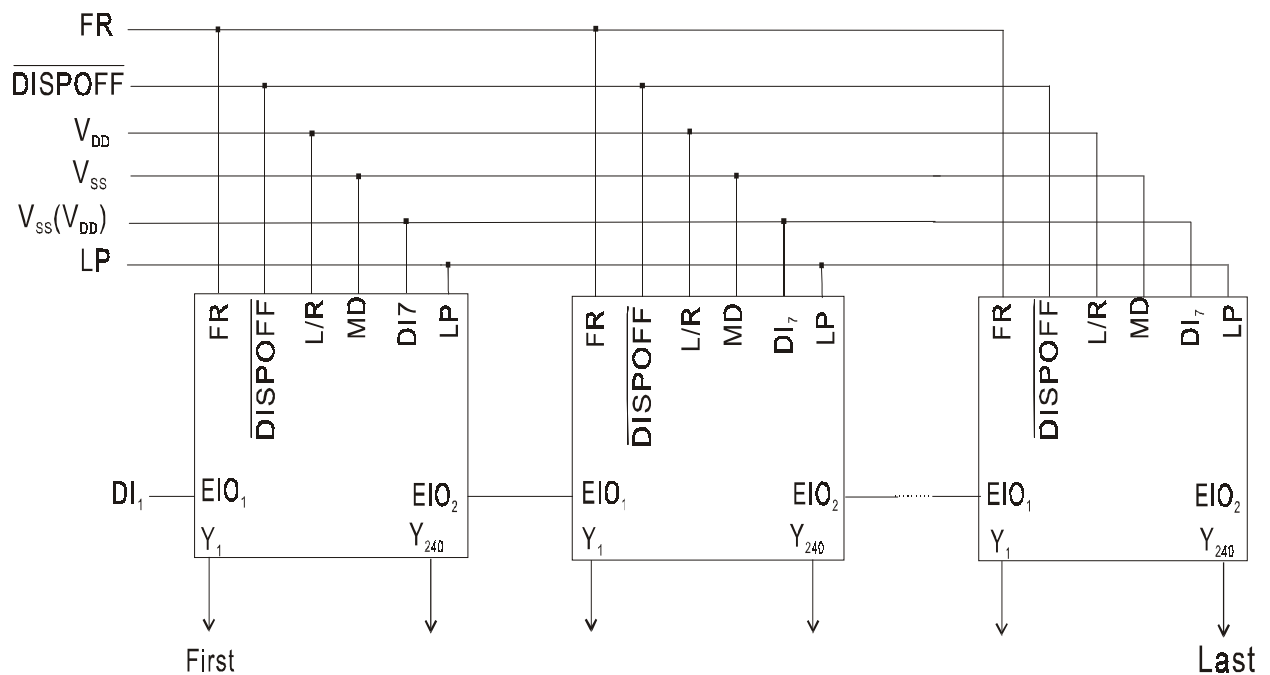

Fig.12 Single Mode (Shifting toward right)

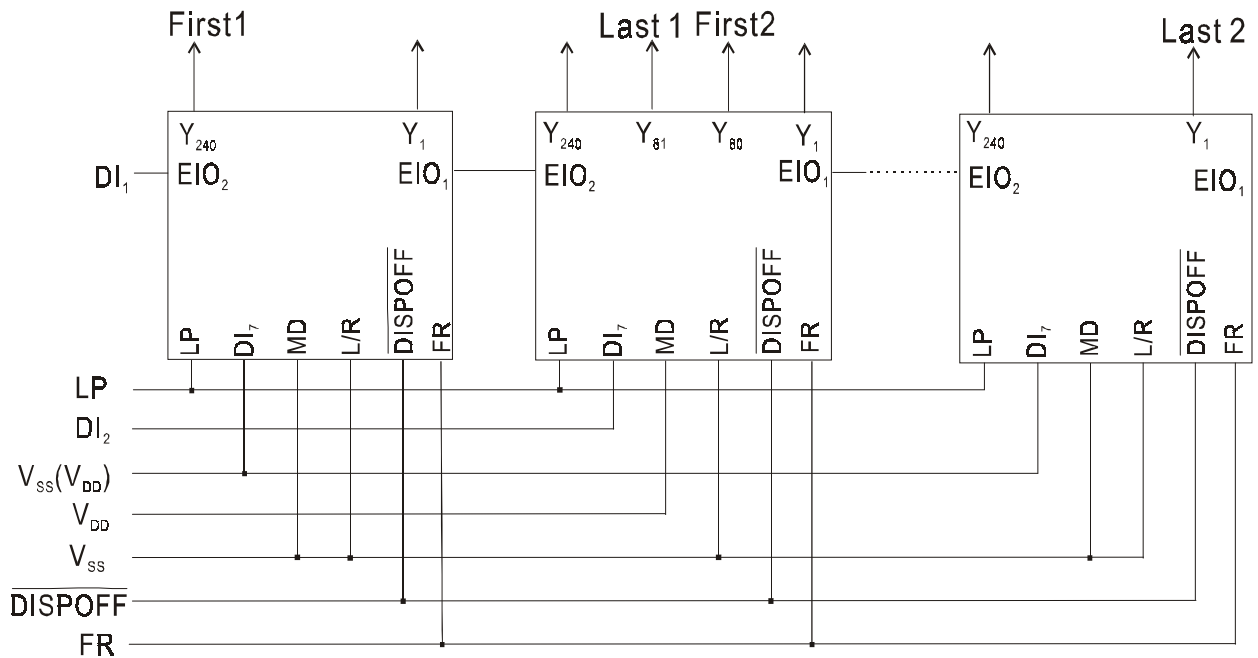

Fig.13 Dual Mode (Shifting toward left)

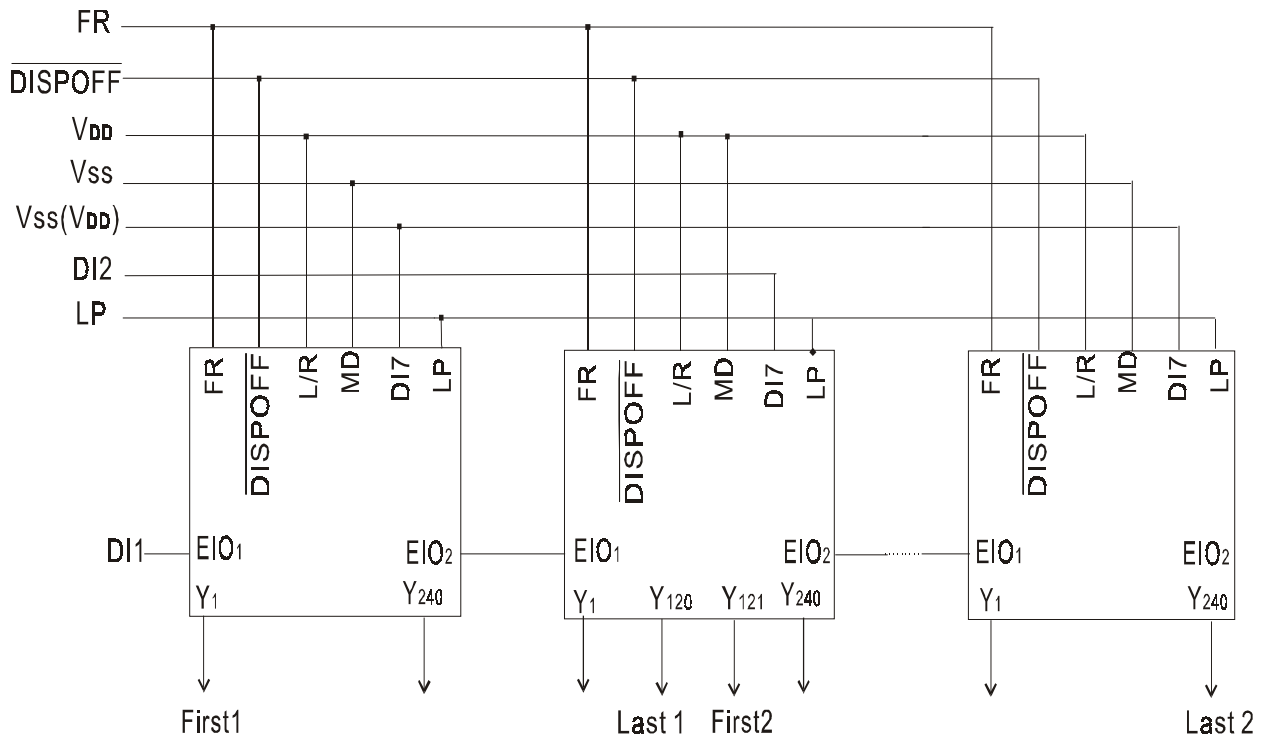

Fig.14 Dual Mode (Shifting toward right)

## Absolute Maximum Ratings

Parameter	Symbol	Conditions	Applicable Pins	Ratings	Unit
Supply voltage(1)	$V_{DD}$	Ta=25°C Referenced to $V_{SS}$ (0 V)	$V_{DD}$	-0.3 to +7.0	V
Supply voltage(2)	$V_0$		$V_{0L}, V_{0R}$	-0.3 to +45.0	V
	$V_{12}$		$V_{12L}, V_{12R}$	-0.3 to $V_0+0.3$	V
	$V_{43}$		$V_{43L}, V_{43R}$	-0.3 to $V_0+0.3$	V
	$V_5$		$V_{5L}, V_{5R}$	-0.3 to $V_0+0.3$	V
Input voltage	$V_I$	Referenced to $V_{SS}$	DI <sub>0-7</sub> , XCK, LP, L/R, FR, MD, S/C, EIO <sub>1</sub> , EIO <sub>2</sub> , $\overline{\text{DISPOFF}}$	-0.3 to $V_{DD}+0.3$	V
Storage temperature	Tstg			-45 to +125	°C

Tab.11

## Recommended Operating Conditions

Parameter	Symbol	Conditions	Applicable pins	Min.	Typ.	Max.	Unit
Supply voltage(1)	$V_{DD}$	Referenced to $V_{SS}$ (0 V)	$V_{DD}$	+2.5		+5.5	V
Supply voltage(2)	$V_0$		$V_{0L}, V_{0R}$	+15.0		+40	V
Storage temperature	$T_a$			-20		+85	°C

Tab.12

Note: Ensure that voltages are set such that  $V_{SS} \leq V_5 < V_{43} < V_{12} < V_0$ .

## Electrical Characteristics

### DC Characteristics

(Segment Mode)

( $V_{SS}=V_5=0\text{ V}$ ,  $V_{DD}=+2.5\text{V to }+5.5\text{V}$ ,  $V_0=+15.0\text{ to }+40\text{ V}$ ,  $T_a=-20\text{ to }+85\text{ }^\circ\text{C}$ )

Parameter	Symbol	Conditions		Applicable pins	Min.	Typ.	Max.	Unit
Input voltage	$V_{IH}$			$DI_{0-7}$ , XCK, LP, L/R, FR,	$0.8V_{DD}$			V
	$V_{IL}$			MD, S/C, $EIO_1$ , $EIO_2$ , DISPOFF			$0.2V_{DD}$	V
Output voltage	$V_{OH}$	$I_{OH}=-0.4\text{mA}$		$EIO_1$ , $EIO_2$	$V_{DD}-0.4$			V
	$V_{OL}$	$I_{OL}=+0.4\text{mA}$						+0.4
Input leakage current	$I_{LIH}$	$V_I=V_{DD}$		$DI_{0-7}$ , XCK, LP, L/R, FR, MD, S/C, $EIO_1$ , $EIO_2$ , DISPOFF			+10.0	$\mu\text{A}$
	$I_{LIL}$	$V_I=V_{SS}$					-10.0	$\mu\text{A}$
Output resistance	$R_{ON}$	$ \Delta V_{ON} =0.5\text{V}$	$V_0=+40.0\text{V}$	$Y_1 \sim Y_{240}$		1.0	1.5	$\text{K}\Omega$
			$V_0=+30.0\text{V}$			1.5	2.0	
			$V_0=+20.0\text{V}$			2.0	2.5	
Stand-by current	$I_{STB}$	*1		$V_{SS}$			75.0	$\mu\text{A}$
Consumed current(1) (Deselection)	$I_{DD1}$	*2		$V_{DD}$			2.0	$\text{mA}$
Consumed current(2) (Selection)	$I_{DD2}$	*3		$V_{DD}$			12.0	$\text{mA}$
Consumed current	$I_0$	*4		$V_0$			1.5	$\text{mA}$

Tab.13

Note:

\*1  $V_{DD}=+5.0\text{V}$ ,  $V_0=+40\text{V}$ ,  $V_I=V_{SS}$ .

\*2  $V_{DD}=+5.0\text{V}$ ,  $V_0=+40\text{V}$ ,  $f_{XCK}=20\text{MHz}$ , No-load,  $EI=V_{DD}$ .

The input data is turned over by data taking clock (4-bit parallel input mode)

\*3  $V_{DD}=+5.0\text{V}$ ,  $V_0=+40\text{V}$ ,  $f_{XCK}=20\text{MHz}$ , No-load,  $EI=V_{SS}$ .

The input data is turned over by data taking clock (4-bit parallel input mode).

\*4  $V_{DD}=+5.0\text{V}$ ,  $V_0=+40\text{V}$ ,  $f_{XCK}=20\text{MHz}$ ,  $f_{LP}=41.6\text{KHz}$ ,  $f_{FR}=80\text{Hz}$ , No-load.

The input data is turned over by data taking clock (4-bit parallel input mode).

(Common Mode)

( $V_{SS}=V_5=0\text{ V}$ ,  $V_{DD}=+2.5\text{V to }+5.5\text{V}$ ,  $V_0=+15.0\text{ to }+40\text{ V}$ ,  $T_a=-20\text{ to }+85\text{ }^\circ\text{C}$ )

Parameter	Symbol	Conditions	Applicable pins	Min.	Typ.	Max.	Unit	
Input voltage	$V_{IH}$		$DI_{0-7}$ , XCK, LP, L/R, FR, MD,	$0.8V_{DD}$			V	
	$V_{IL}$		S/C, $EIO_1$ , $EIO_2$ , DISPOFF			$0.2V_{DD}$	V	
Output voltage	$V_{OH}$	$I_{OH}=-0.4\text{mA}$	$EIO_1$ , $EIO_2$	$V_{DD}-0.4$			V	
	$V_{OL}$	$I_{OL}=+0.4\text{mA}$					+0.4	V
Input leakage current	$I_{LH}$	$V_1=V_{DD}$	$DI_{0-6}$ , LP, L/R, FR, MD, S/C, DISPOFF			+10.0	$\mu\text{A}$	
	$I_{LL}$	$V_1=V_{SS}$	$DI_{0-7}$ , XCK, LP, L/R, FR, MD, S/C, $EIO_1$ , $EIO_2$ , DISPOFF			-10.0	$\mu\text{A}$	
Input pull-down current	$I_{PD}$	$V_1=V_{DD}$	XCK, $EIO_1$ , $EIO_2$ , $DI_7$			100.0	$\mu\text{A}$	
Output resistance	$R_{ON}$	$ \Delta V_{ON} =0.5\text{V}$	$V_0=+40.0\text{V}$ $V_0=+30.0\text{V}$ $V_0=+20.0\text{V}$	$Y_1 \sim Y_{240}$		1.0	1.5	K $\Omega$
						1.5	2.0	
						2.0	2.5	
Stand-by current	$I_{STB}$	*1	$V_{SS}$			75.0	$\mu\text{A}$	
Consumed current(1)	$I_{DD}$	*2	$V_{DD}$			120.0	$\mu\text{A}$	
Consumed current(2)	$I_O$	*2	$V_0$			240.0	$\mu\text{A}$	

Tab.14

\*1  $V_{DD}=+5.0\text{V}$ ,  $V_0=+40\text{V}$ ,  $V_1=V_{SS}$ .

\*2  $V_{DD}=+5.0\text{V}$ ,  $V_0=+40\text{V}$ ,  $f_{LP}=41.6\text{KHz}$ ,  $f_{FR}=80\text{Hz}$  case of 1/480 duty operation, No-load.

## AC Characteristics

(Segment Mode 1)

( $V_{SS}=V_5=0$  V,  $V_{DD}=+4.5$  V to  $+5.5$  V,  $V_0=+15.0$  to  $+40$  V,  $T_a=-20$  to  $+85$  °C )

Parameter	Symbol	Condition	Min.	Typ.	Max.	Unit
Shift clock period *1	$t_{WCK}$	$t_r, t_f \leq 10$ ns	50			ns
Shift clock "H" pulse width	$t_{WCKH}$		15			ns
Shift clock "L" pulse width	$t_{WCKL}$		15			ns
Data setup time	$t_{DS}$		10			ns
Data Hold time	$t_{DH}$		12			ns
Latch pulse "H" pulse width	$t_{WLPH}$		15			ns
Shift clock rise to Latch pulse rise time	$t_{LD}$		0			ns
Shift clock fall to Latch pulse fall time	$t_{SL}$		30			ns
Latch pulse rise to Shift clock rise time	$t_{LS}$		25			ns
Latch pulse fall to Shift clock fall time	$t_{LH}$		25			ns
Input signal rise time *2	$t_r$				50	ns
Input signal fall time *2	$t_f$				50	ns
Enable setup time	$t_s$		10			ns
$\overline{\text{DISPOFF}}$ removal time	$t_{SD}$		100			ns
$\overline{\text{DISPOFF}}$ " L" pulse width	$t_{WDL}$		1.2			$\mu$ s
Output delay time(1)	$t_D$	$C_L=15$ pF			30	ns
Output delay time(2)	$t_{pd1}, t_{pd2}$	$C_L=15$ pF			1.2	$\mu$ s
Output delay time(3)	$t_{pd3}$	$C_L=15$ pF			1.2	$\mu$ s

Tab.15

Note:

\*1 Take the cascade connection into consideration.

\*2  $(t_{CK}-t_{WCKH}-t_{WCKL})/2$  is maximum in the case of high speed operation.

(Segment Mode 2)

( $V_{SS}=V_5=0$  V,  $V_{DD}=+2.5$ V to  $+4.5$ V,  $V_0=+15.0$  to  $+40$  V,  $T_a=-20$  to  $+85$  °C )

Parameter	Symbol	Condition	Min.	Typ.	Max.	Unit
Shift clock period *1	$t_{WCK}$	$t_r, t_f \leq 11$ ns	66			ns
Shift clock "H" pulse width	$t_{WCKH}$		23			ns
Shift clock "L" pulse width	$t_{WCKL}$		23			ns
Data setup time	$t_{DS}$		15			ns
Data Hold time	$t_{DH}$		23			ns
Latch pulse "H" pulse width	$t_{WLPH}$		30			ns
Shift clock rise to Latch pulse rise time	$t_{LD}$		0			ns
Shift clock fall to Latch pulse fall time	$t_{SL}$		50			ns
Latch pulse rise to Shift clock rise time	$t_{LS}$		30			ns
Latch pulse fall to Shift clock fall time	$t_{LH}$		30			ns
Input signal rise time *2	$t_r$				50	ns
Input signal fall time *2	$t_f$				50	ns
Enable setup time	$t_s$		15			ns
$\overline{\text{DISPOFF}}$ removal time	$t_{SD}$		100			ns
$\overline{\text{DISPOFF}}$ " L" pulse width	$t_{WDL}$		1.2			$\mu$ s
Output delay time(1)	$t_D$	$C_L=15$ pF			41	ns
Output delay time(2)	$t_{pd1}, t_{pd2}$	$C_L=15$ pF			1.2	$\mu$ s
Output delay time(3)	$t_{pd3}$	$C_L=15$ pF			1.2	$\mu$ s

Tab.16

Note:

\*1 Take the cascade connection into consideration.

\*2  $(t_{CK}-t_{WCKH}-t_{WCKL})/2$  is maximum in the case of high speed operation.

(Segment Mode 3)

( $V_{SS}=V_5=0$  V,  $V_{DD}=+2.5$ V to  $+3.0$ V,  $V_0=+15.0$  to  $+40$  V,  $T_a=-20$  to  $+85$  °C )

Parameter	Symbol	Condition	Min.	Typ.	Max.	Unit
Shift clock period *1	$t_{WCK}$	$t_r, t_f \leq 11$ ns	82			ns
Shift clock "H" pulse width	$t_{WCKH}$		28			ns
Shift clock "L" pulse width	$t_{WCKL}$		28			ns
Data setup time	$t_{DS}$		20			ns
Data Hold time	$t_{DH}$		23			ns
Latch pulse "H" pulse width	$t_{WLPH}$		30			ns
Shift clock rise to Latch pulse rise time	$t_{LD}$		0			ns
Shift clock fall to Latch pulse fall time	$t_{SL}$		65			ns
Latch pulse rise to Shift clock rise time	$t_{LS}$		30			ns
Latch pulse fall to Shift clock fall time	$t_{LH}$		30			ns
Input signal rise time *2	$t_r$				50	ns
Input signal fall time *2	$t_f$				50	ns
Enable setup time	$t_s$		15			ns
$\overline{\text{DISPOFF}}$ removal time	$t_{SD}$		100			ns
$\overline{\text{DISPOFF}}$ " L" pulse width	$t_{WDL}$		1.2			$\mu\text{s}$
Output delay time(1)	$t_D$	$C_L=15\text{pF}$			57	ns
Output delay time(2)	$t_{pd1}, t_{pd2}$	$C_L=15\text{pF}$			1.2	$\mu\text{s}$
Output delay time(3)	$t_{pd3}$	$C_L=15\text{pF}$			1.2	$\mu\text{s}$

Tab.17

Note:

\*1 Take the cascade connection into consideration.

\*2  $(t_{CK}-t_{WCKH}-t_{WCKL})/2$  is maximum in the case of high speed operation.



(Timing Characteristics of Segment Mode)

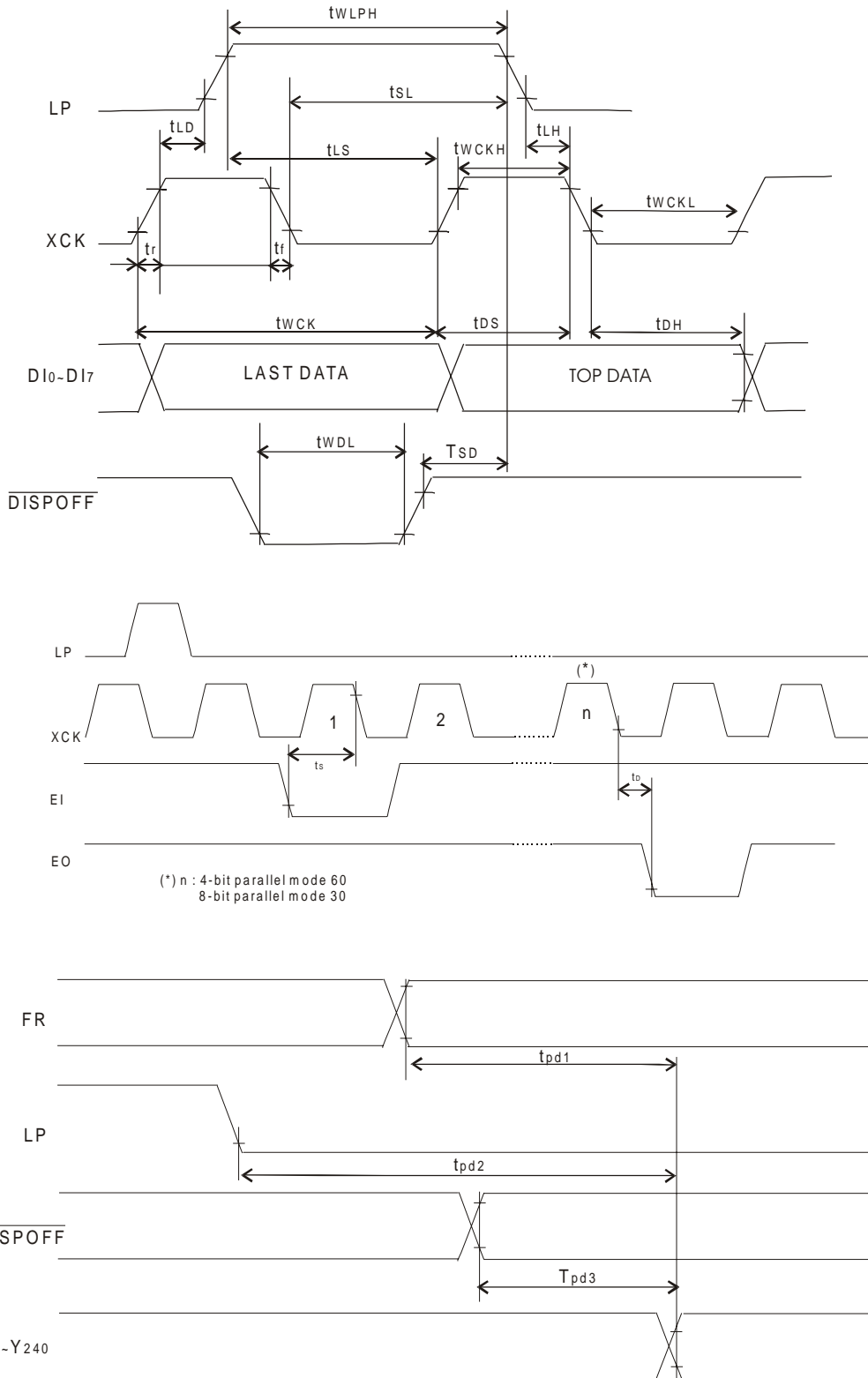

Fig.15

(Common Mode)

( $V_{SS}=V_5=0$  V,  $V_{DD}=+2.5$ V to +5.5V,  $V_0=+15.0$  to +40 V,  $T_a=-20$  to +85 °C )

Parameter	Symbol	Condition	Min.	Typ.	Max.	Unit
Shift clock period	$t_{WLP}$	$t_r, t_f \leq 20$ ns	250			ns
Shift clock "H" pulse width	$t_{WLPH}$	$V_{DD}=+5.0$ V $\pm$ 10%	15			ns
		$V_{DD}=+2.5$ V~ +4.5V	30			
Data setup time	$t_{SU}$		30			ns
Data Hold time	$t_H$		50			ns
Input signal rise time	$t_r$				50	ns
Input signal fall time	$t_f$				50	ns
$\overline{\text{DISPOFF}}$ removal time	$t_{SD}$		100			ns
$\overline{\text{DISPOFF}}$ " L" pulse width	$t_{WDL}$		1.2			$\mu$ s
Output delay time(1)	$t_{DL}$	$C_L=15$ pF			200	ns
Output delay time(2)	$t_{pd1}, t_{pd2}$	$C_L=15$ pF			1.2	$\mu$ s
Output delay time(3)	$t_{pd3}$	$C_L=15$ pF			1.2	$\mu$ s

Tab.17

(Timing Characteristics of Common Mode)

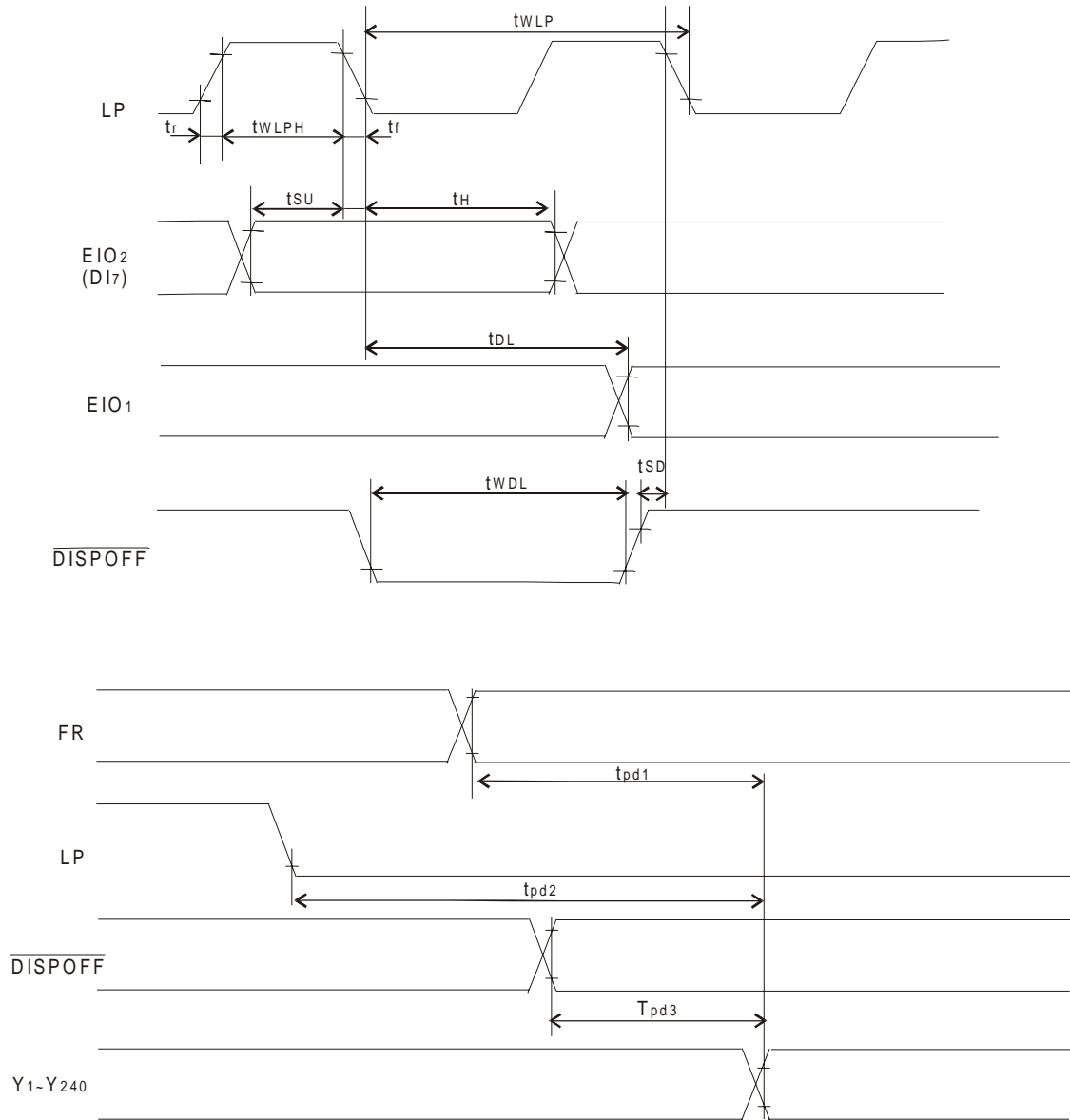

[L/R="L"]

Fig.16

## Example of system Configuration

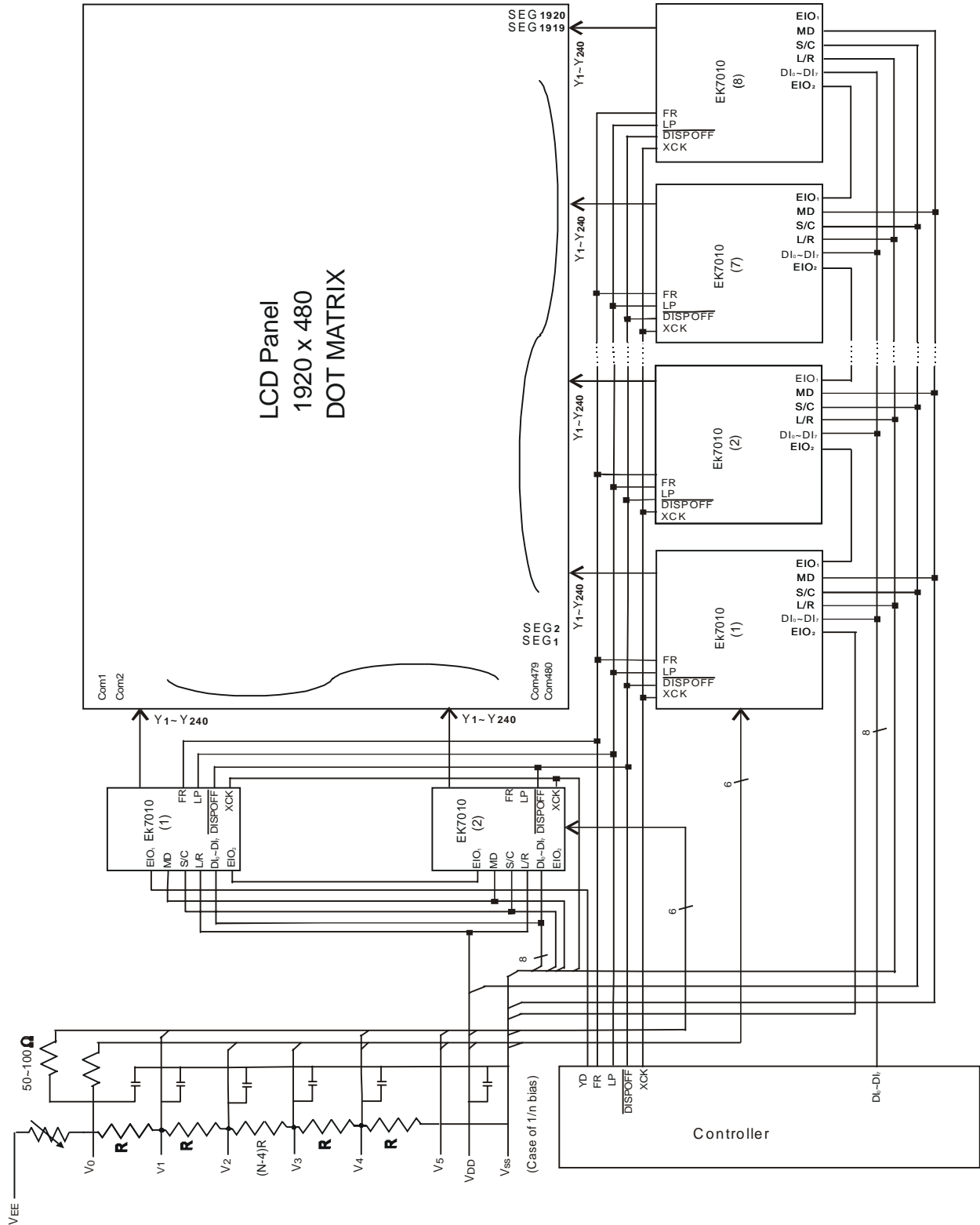

Fig.17

## **Example of Typical Characteristic**

<b>Parameter</b>	<b>Condition</b>	<b>Min.</b>	<b>Typ.</b>	<b>Max.</b>	<b>Unit</b>
Typical Fundamental Rating Propagation Delay Time	$T_a=+25^{\circ}\text{C}$ , $V_{SS}=0\text{V}$ , $V_{DD}=+5.0\text{V}$		10		ns

Tab.18

## Precaution

- Precaution when connecting or disconnecting the power  
This LSI has a high-voltage LCD driver, so it may be permanently damaged by a high current which may flow if a voltage is supplied to the LCD driver power supply while the logic system power supply is floating. The detail is as follows.
- When connecting the power supply, connect the LCD drive power after connecting the logic system power. Furthermore, when disconnecting the power, disconnect the logic system power after disconnecting the LCD drive power.
- We recommend you connecting the serial resistor(50~100Ω ) or fuse to the LCD drive power  $V_0$  of the system as a current limiter. And set up the suitable value of the resistor in consideration of LCD display grade.

And when connecting the logic power supply, the logic condition of this LSI inside is insecurity. Therefore connect the LCD drive power supply after resetting logic condition of this LSI inside on  $\overline{\text{DISPOFF}}$  function. After that, cancel the  $\overline{\text{DISPOFF}}$  function after the LCD drive power supply has become stable. Furthermore, when disconnecting the power, set the LCD drive output pins to level  $V_s$  on  $\overline{\text{DISPOFF}}$  function. After that, disconnect the logic system power after disconnecting the LCD drive power. When connecting the power supply, show the following recommend sequence.

