



Doc.No.: AFY800480A0-5.0N6NTN-C

REV : A0

PAGE : 1/21

EFFECTIVE DATE : 2014-07-20

SPECIFICATION OF LCD MODULE

MODULE NO.: AFY800480A0-5.0N6NTN-C

Customer Approval:

Accept

Reject

FUTURE FOCUS	SIGNATURE	DATE
PREPARED BY		
CHECKED BY		
APPROVED BY		

Sample Version	Doc. Version	DATE	DESCRIPTION	CHECKED BY
----------------	--------------	------	-------------	------------



Doc.No.: AFY800480A0-5.0N6NTN-C

REV : A0

PAGE : 2/21

EFFECTIVE DATE : 2014-07-20

001	A0	2014-07-20	First Release.	
-----	----	------------	----------------	--

CONTENTS

List	Description	Page No.
	NUMBER SYSTEM INTRODUCTION	4
1	GENERAL SPECIFICATIONS	4
2	BLOCK DIAGRAM	5
3	DIMENSIONAL OUTLINE	5
4	PIN DESCRIPTION	7
5	ELECTRICAL CHARACTERISTICS	9
6	INPUT SIGNAL TIMING	12
7	OPTICAL CHARACTERISTICS	18
8	RELIABILITY	20
9	SPECIFICATION OF QUALITY ASSURANCE	20
10	GENERAL PRECAUTION	20
11	LIMITED WARRANTY	20
12	PACKAGE	21

NUMBER SYSTEM INTRODUCTION:

AFY240320A1-2.8N6NTN-C:

AF: Orient Display TFT;

Y: JAZZ TFT;

240320: Length * width pixel;

A1: Product Version;

2.8: Diagonal Dimension;

N: LCD Mode (N: TN; I: IPS; V: VA)

6: Viewing Direction (6-> 6:00; 12->12:00; Unavailable for IPS and VA);

N: Temperature Range (N: Normal; W: Wide);

T: Polarizer (T:Transmissive; F:Transflective);

N: Luminance (N: Normal <300 nit; M: Middle >=300 & <600 nit;
H: High >=600 nit);

C: TP Option (R: Resistive TP; C: Capacitive TP; N: Without TP);

1. GENERAL SPECIFICATIONS:

ITEM	SPECIFICATION	UNIT
OUTLINE DIMENSIONS	121.0(W) X75.9 (H) X 5.0(D)	mm
DISPLAY SIZE	5.0	inch
DOT PITCH	0.135mmX0.135mm	mm
NUMBER OF DOTS	800* (RGB) *480	-
DRIVER IC	ILI5960D / ILI6126C	-
LCD TYPE	TFT(262K) TRANSMISSIVE	-
INTERFACE	RGB 24 BITS	
BACKLIGHT TYPE	LED White	-
VIEWING DIRECTION	6 O'clock	-
GRAY SCALE DIRECTION	6 O'clock	-

*See attached drawing for details.

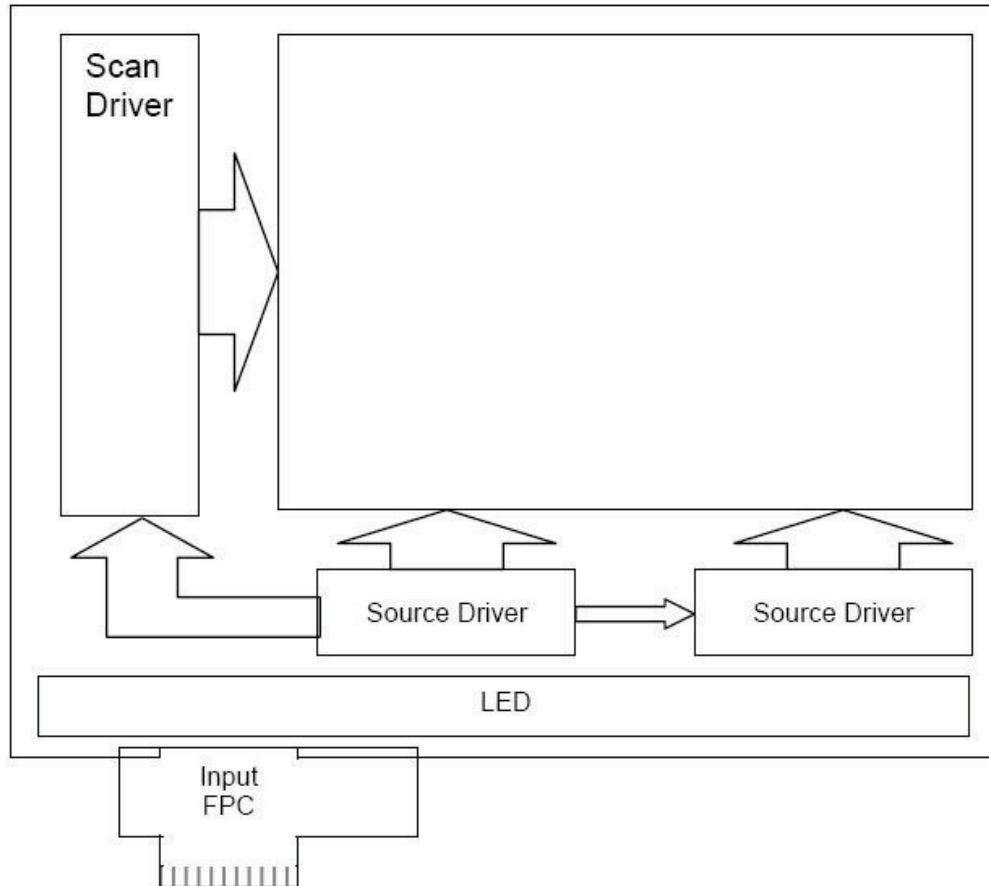
2.BLOCK DIAGRAM:

4. PIN DESCRIPTION:

NO.	PIN NAME	Type	Description
1	LED-	P	Power supply for LED (Cathode)
2	LED+	P	Power supply for LED (Anode)
3	/	/	NC
4	VDD	P	Power voltage
5	R0	I	RED data signal(LSB)
6	R1	I	RED data signal
7	R2	I	RED data signal
8	R3	I	RED data signal
9	R4	I	RED data signal
10	R5	I	RED data signal
11	R6	I	RED data signal
12	R7	I	RED data signal(MSB)
13	G0	I	GREEN data signal(LSB)
14	G1	I	GREEN data signal
15	G2	I	GREEN data signal
16	G3	I	GREEN data signal
17	G4	I	GREEN data signal
18	G5	I	GREEN data signal
19	G6	I	GREEN data signal
20	G7	I	GREEN data signal(MSB)
21	B0	I	BLUE data signal(LSB)
22	B1	I	BLUE data signal
23	B2	I	BLUE data signal
24	B3	I	BLUE data signal
25	B4	I	BLUE data signal
26	B5	I	BLUE data signal
27	B6	I	BLUE data signal
28	B7	I	BLUE data signal(MSB)
29	GND	P	Ground(0V)
30	DOTCLK	I	Pixel clock signal
31	DISP	I	Display on/ off
32	HSYNC	I	Horizontal synchronizing signal
33	VSNC	I	Vertical synchronizing signal
34	DE	I	Data enable
35	/	/	NC
36	/	/	NC
37	XR(NC)	-	No connection
38	YD(NC)	-	No connection
39	XL(NC)	-	No connection
40	YU(NC)	-	No connection

Note: I: input, O: output, P: Power



Doc.No.: AFY800480A0-5.0N6NTN-C

REV : A0

PAGE : 8/21

EFFECTIVE DATE : 2014-07-20

CTP interface description

Interface NO.	NAME	I/O or connect to	DESCRIPTION
1	GND	P	Ground
2	INT	O	State change interrupt
3	RESET	I	Reset low
4	VDD	P	Power of CTP DC3.3V
5	SCL	I	Serial interface clock
6	SDA	I/O	Serial interface data

NOTE: (FOR CTP)

Please download details at <http://www.orientdisplay.com/pdf/mXT540E.pdf>

5.ELECTRICAL CHARACTERISTICS

5.1 Absolute Maximum Ratings

Item	Symbol	Values		Unit	Remark
		Min	Max.		
Power Supply for Pump	VDD	-0.3	4.5	V	

Note: Stresses beyond those given in the Absolute Maximum Rating table may cause operational errors or damage to the device. For normal operational conditions see AC/DC Electrical Characteristics

5.2DC Characteristics

5.2.1 Operating Conditions

Item	Symbol	Values			Unit	Conditions
		Min	Typ.	Max.		
Charge Pump Supply Voltage	PVDD	3	3.3	3.6	V	PWR_SEL=H
Digital Supply Voltage	VDD	3	3.3	3.6	V	PWR_SEL=H
Digital Interface Supply	VDDIO	1.65	1.8	VDD	V	
Digital Input Voltage	Di	0	-	VDDIO	V	
OTP Supply Voltage	V_OTP	7.4	7.5	7.6	V	
VCOM AC Voltage	VCOMH-VCOML	3.46	-	6.2	V	

5.2.2 DC Characteristics for Digital Circuit

Item	Symbol	Values			Unit	Conditions
		Min	Typ.	Max.		
Low Level Input Voltage	Vil	GND	-	0.3xVDDIO	v	
High Level Input Voltage	Vih	0.7xVDDIO	-	VDDIO	uA	
High Level Output Voltage	Voh	VDDIO-0.4	-	VDDIO	ohm	
Low Level Output Voltage	Vol	GND	-	GND+0.4	uA	
Input Leakage Current	Iil			±1.0		
Pull High/Low Resistor	Rp	-	100K	-	ohm	

5.2.3 DC Characteristics for Analog Circuit

VDDIO=1.8V, VDD = 3.3V, AVDD = 6V, AGND = 0V, TA = - 20°C to 80 °C

Item	Symbol	Values			Unit	Conditions
		Min	Typ.	Max.		
Analog Supply Voltage	VDD2		5		V	
Positive High-voltage power	VGH	9	15	16	V	No Load. By VGH_SEL setting.
Negative High-voltage power	VGL	-11	-10	-7	V	No Load. By VGL_SEL setting.
VCOMH Output Level	VCOMH	3.26		5.8	V	By VCOMH setting.
VCOML Output Level	VCOML	-2		-0.2	V	By VCOML setting
Output Voltage Deviation	Vod	-	±20	±35	mV	VO = 0.15V ~ 0.5V, 3.45V~3.8V
		-	±15	±20		VO = 0.5V ~ 3.45V
Output Dynamic Range	Vdr	0.2	-	5.3		MVA Mode
		0.15		4.8		TN Mode
VCOM Low Level Output Current	IOLFRP		-10		mA	VCOM AC output = 0.5V
VCOM High Level Output Current	IOHFRP		-10		mA	VCOM AC output = 5.7V
Analog Standby Current	Ilast	-	-	20	uA	
Analog Operation Current	IDD	-	5.0	-	mA	Without panel loading

5.3 DC BackLight Unit

Item	Symbol	Min.	Typ.	Max.	Unit	Remark
Average luminous Intensity	Iv		250		cd/ m2	IF=40mA
Chromaticity Coordinates	X	0.234	0.284	0.334		IF=40mA
	Y	0.273	0.323	0.373		IF=40mA
Forward Voltage	VF		19.2	20.4	V	IF=40mA
Reverse Current	IR			50	μA	VR=20V,1LED
Luminous Tolerance	IV-M	80			%	(MIN/MAX)×100
Power Dissipation	Pd		768		mW	
Peak Forward Current	I _{fp}		100		mA	
Reverse Voltage	VR		5		V	

5.3.1 Internal Circuit Diagram

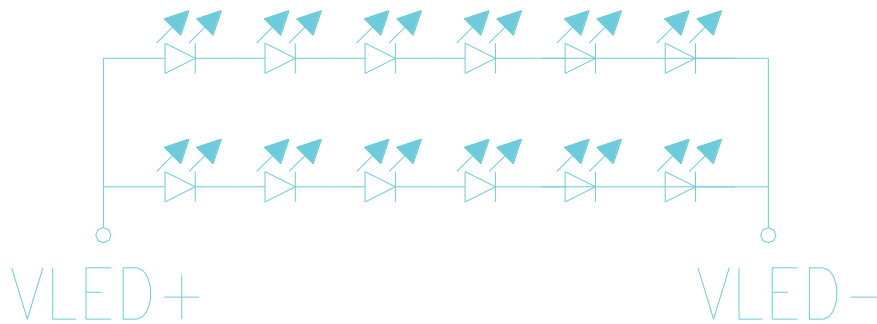

40mA 19.2V

5.4 POWER ON/OFF SEQUENCE

To prevent the device damage from latch up, the power ON/OFF sequence shown below must be followed.

Power ON: VDD, DGND → AVDD, AGND → V1 to V14

Power OFF: V1 to V14 → AVDD, AGND → VDD, DGND

In order to prevent ILI6126 from power ON reset fail, the rising time (t_{POR}) of the digital power supply VDD should be maintained within given specifications. The power ON/OFF timing sequence is illustrated as below:

REV=L & NBWB=H

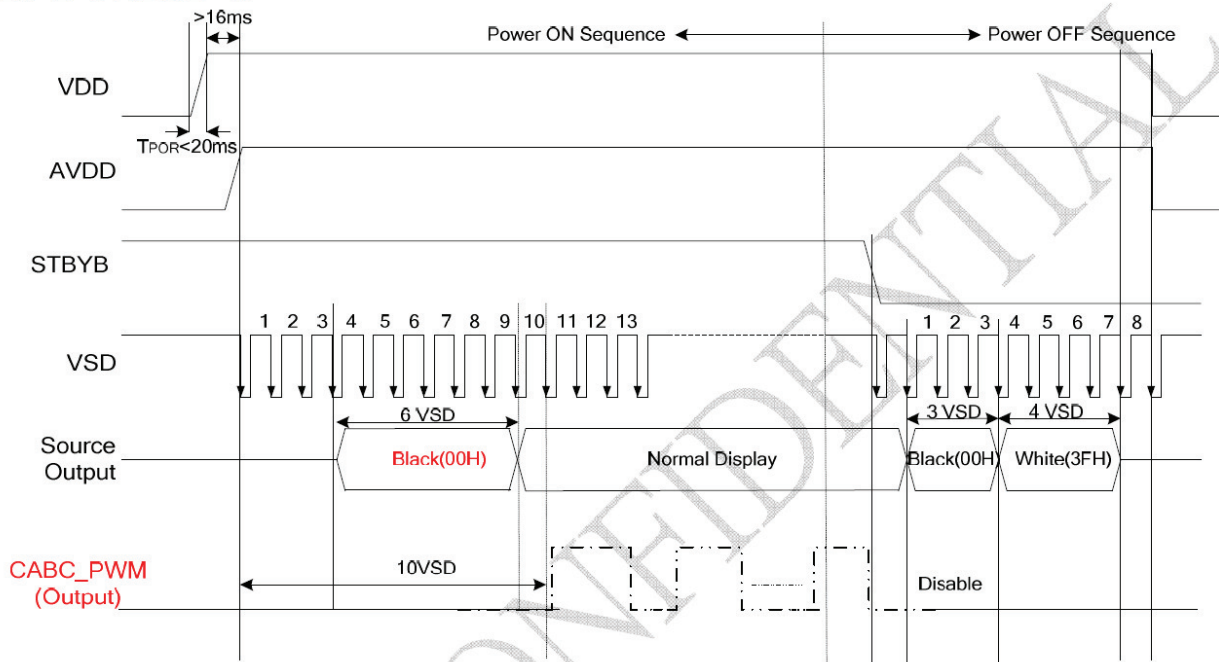

5.5 Standby On/Off Control

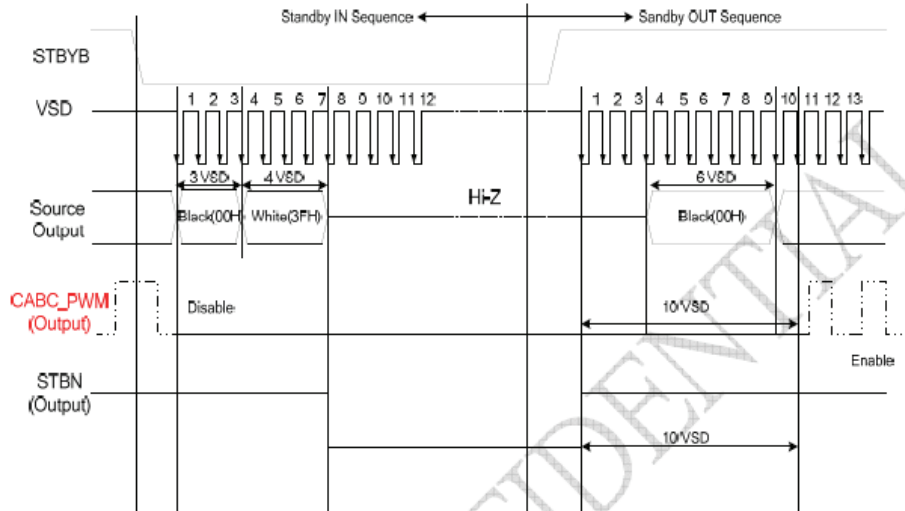

6.INPUT SIGNAL TIMING

6.1 AC Characteristics

A.1: HV Mode

Horizontal input timing

Parameter	Symbol	Value			Unit	Note
		Min.	Typ.	Max.		
Horizontal display area	thd	800			DCLK	
DCLK frequency	fclk	-	33.3	50	MHz	
1 Horizontal Line	th	908	928	1010	DCLK	thb+thpw=88 DCLK is fixed.
HSD pulse width	thpw	4	48	64		
HSD Back Porch (Blanking)	thb	20	40	84		
HSD Front Porch	thfp	20	40	122		

Vertical input timing

Parameter	Symbol	Value			Unit	Note
		Min.	Typ.	Max.		
Vertical display area	tvd	480			H	
VSD period time	tv	515	525	-	H	
VSD pulse width	tpw	1	3	31	H	tpw+tvb=32H is fixed
VSD Back Porch (Blanking)	tvb	1	29	31	H	
VSD Front Porch	tvfp	3	13	-	H	

A.2: DE Mode

Parameter	Symbol	Spec			Unit
		Min.	Typ.	Max.	
CLK frequency	fclk	-	33.3	50	MHz
DE H period	thpw+thb+thd+thfp = th	920	1000	1010	DCLK
DE H-Display Area	thd	800			DCLK
DE H-Blanking	th-thd	120	200	210	DCLK
DE V period	tpw+tvb+tvd+tvfp	500	512	-	DCLK
DE V-Display Area	tvd	480			th
DE V-Blanking	tv-tvd	20	32	-	th

6.2 AC Timing Diagram

6.2.1 Vertical Input Timing

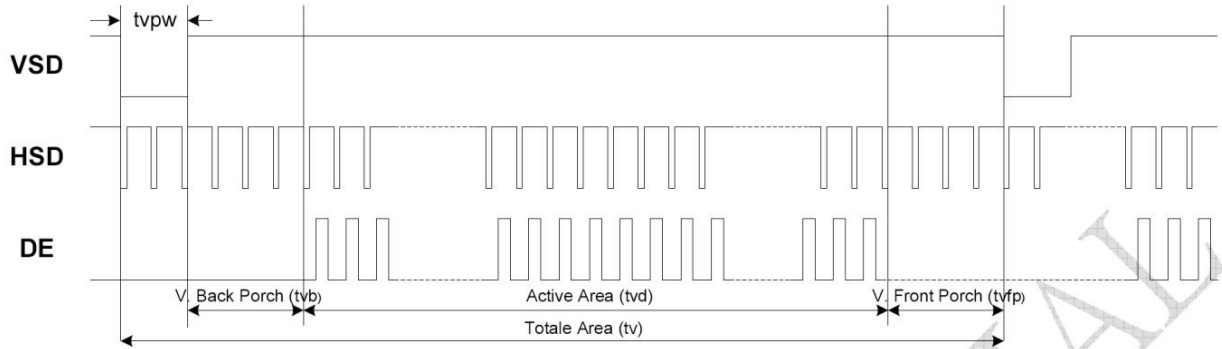

6.2.2 Horizontal Input Timing

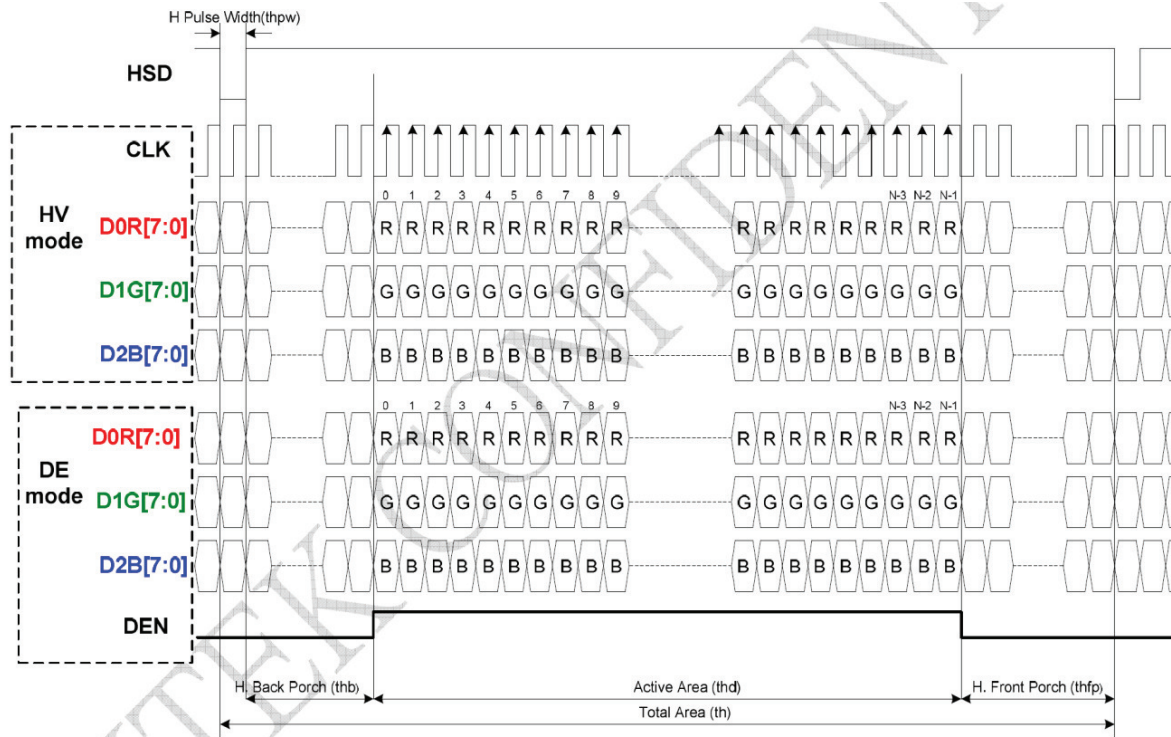

6.2.3 AC Electrical Characteristics

Parameter	Symbol	Min.	Typ.	Max.	Unit	Conditions
VDD Power On Slew rate	TPOR	-	-	20	ms	From 0V to 90% VDD
RSTB pulse width	Trst	10	-	-	us	CLKIN = 45MHz
CLKIN cycle time	Tcph	20			ns	
CLKIN pulse duty	Tcwh	40	50	60	%	
VSD setup time	Tvst	8	-	-	ns	
VSD hold time	Tvhd	8	-	-	ns	
HSD setup time	Thst	8	-	-	ns	
HSD hold time	Thhd	8	-	-	ns	
Data set-up time	Tdsu	8	-	-	ns	D0R[7:0], D1G[7:0], D2B[7:0] to CLKIN
Data hold time	Tdhd	8	-	-	ns	D0R[7:0], D1G[7:0], D2B[7:0] to CLKIN
DE setup time	Tesu	8	-	-	ns	
DE hold time	Tehd	8	-	-	ns	
Output stable time	Tsst	-	-	6	us	10% to 90% target voltage. CL=120pF, R=10K ohm

6.3 Parallel RGB Data Format

6.3.1 Parallel RGB Input Timing Table

Parameter	Symbol	Min.	Typ.	Max.	Unit	Conditions
CLKIN Frequency	Fclk	-	33	50	MHz	VDD = 2.7V ~3.6V
CLKIN Cycle Time	Tclk	20	30	-	ns	
CLKIN Pulse Duty	Tcwh	40	50	60	%	Tclk
Time from HSD to Source Output	Thso	-	64	-	CLKIN	
Time from HSD to LD	Thld	-	64	-	CLKIN	
Time from HSD to STV	Thstv	-	2	-	CLKIN	
Time from HSD to CKV	Thckv	-	20	-	CLKIN	
Time from HSD to OEV	Thoev	-	4	-	CLKIN	
LD Pulse Width	Twld	-	10	-	CLKIN	
CKV Pulse Width	Twckv	-	66	-	CLKIN	
OEV Pulse Width	Twoev	-	92	-	CLKIN	

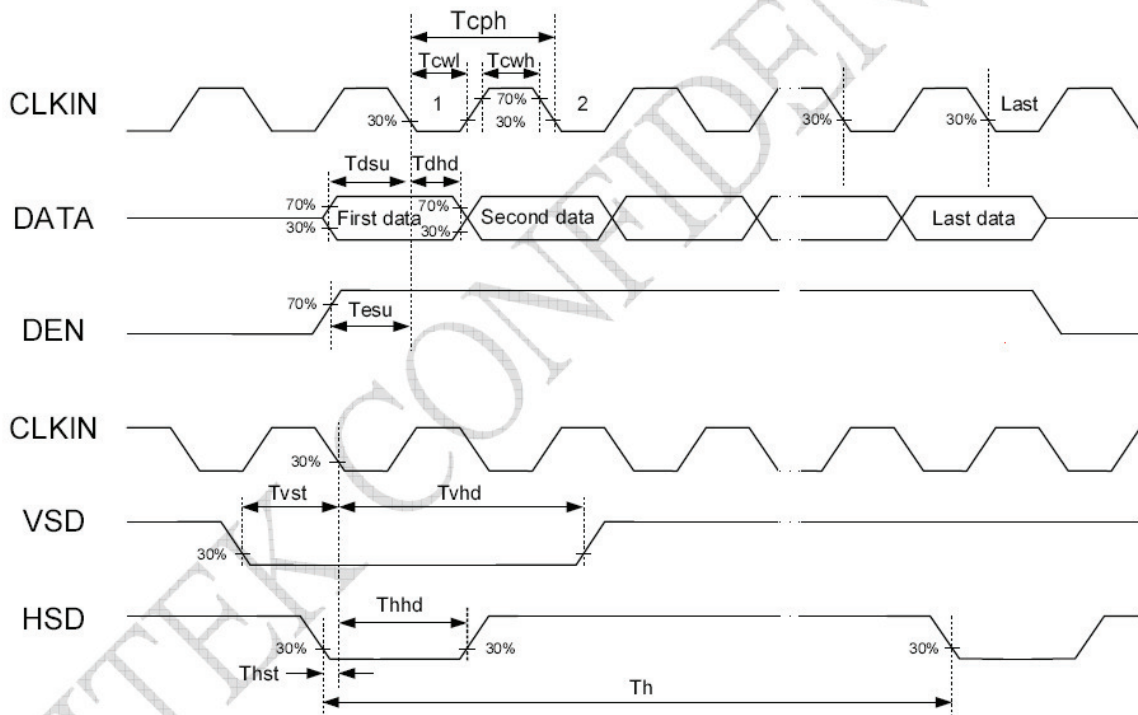

Source output timing diagram

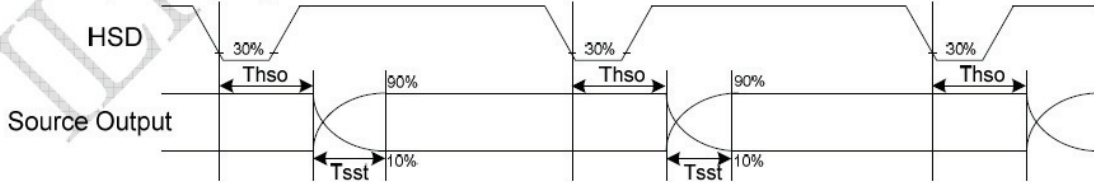

Output Loading condition

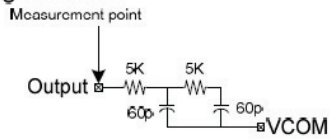

Vertical Timing Diagram of HV Mode (Dual Gate)

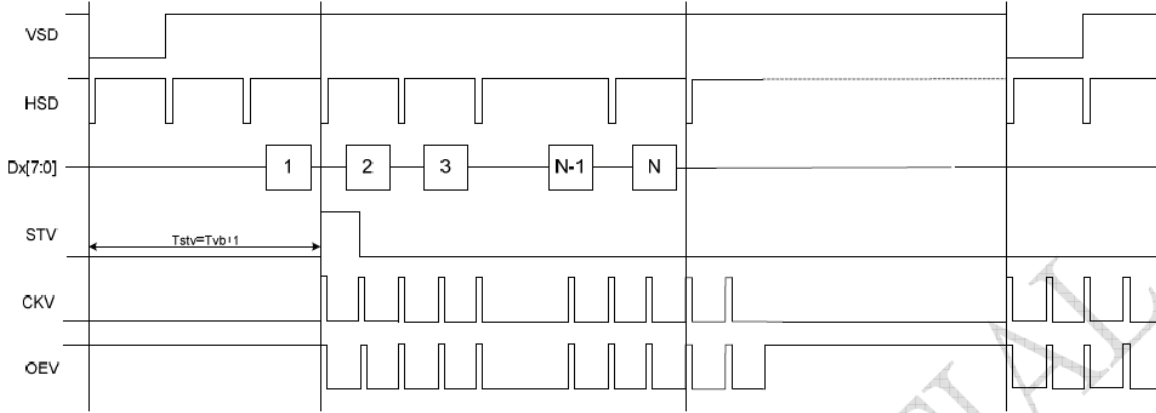

Vertical Timing Diagram of DE Mode (Dual Gate)

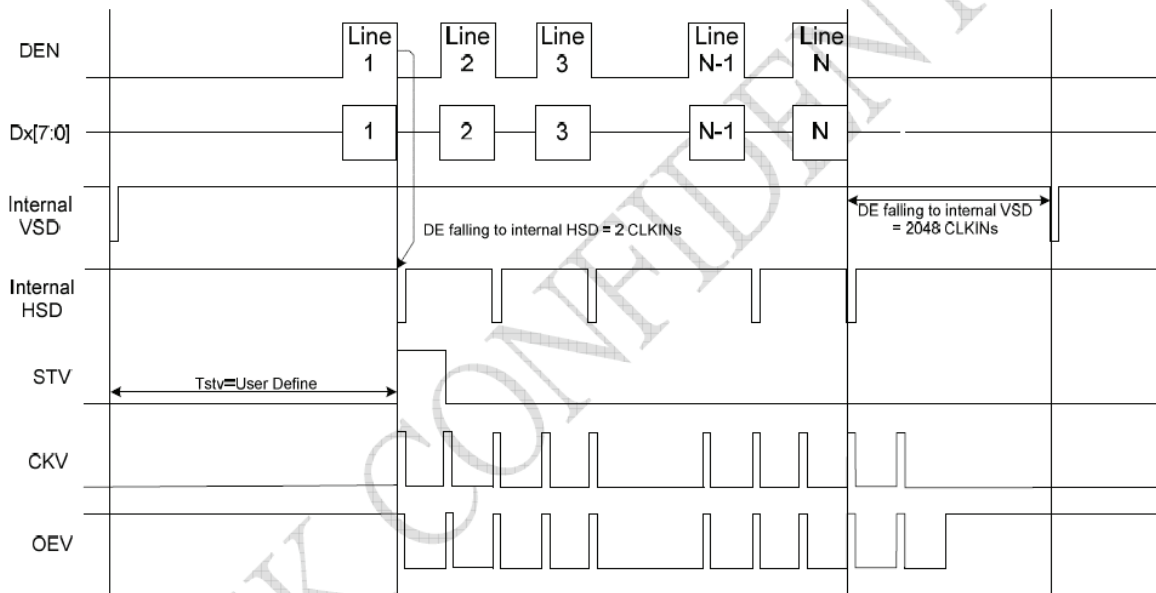

Gate Output Timing Diagram (Dual Gate)

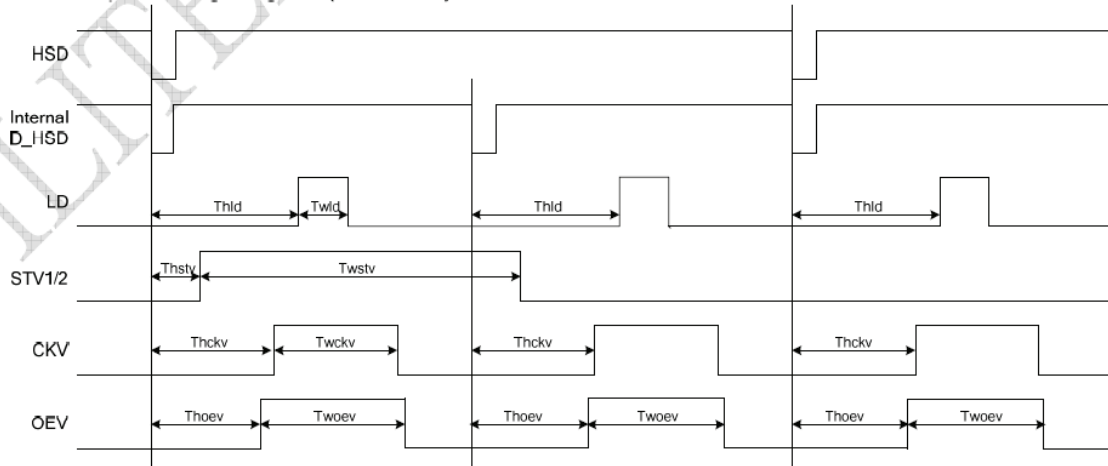



Doc.No.: AFY800480A0-5.0N6NTN-C

REV : A0

PAGE : 17/21

EFFECTIVE DATE : 2014-07-20

6.4 Controller Information

IC: ILI5960D, ILI6126C

Please download IC specification at <http://www.orientdisplay.com/pdf/ILI5960D.pdf>

& <http://www.orientdisplay.com/pdf/ILI6126C.pdf>

7. OPTICAL CHARACTERISTICS

ITEM	SYMBOL	CONDITION	MIN.	TYP.	MAX.	UNIT	REMARK
Transmittance	T		3.3	3.97		%	
Contrast Ratio	CR	*1)		350	-	--	Note 3
Response Time	Tr+ Tf	*3)	-	20		ms	Note 4
Viewing Angle	U	$\theta^{*2)}$	$CR \geq 10$	45	50	-	Note 5
	D			55	60	-	
	L	$\psi^{*2)}$		60	65	-	
	R			60	65	-	
Color Filter Chromaticity	White	x y Y	$\theta = \phi = 0^\circ$	0.297	0.317	0.337	Note 6
				0.304	0.324	0.344	
				27.5	30.5	33.5	
	Red	x y Y	$\theta = \phi = 0^\circ$	0.613	0.633	0.653	
				0.321	0.341	0.361	
				18.3	21.3	24.3	
	Green	x y Y	$\theta = \phi = 0^\circ$	0.304	0.324	0.344	
				0.531	0.551	0.571	
				48.4	52.4	56.4	
	Blue	x y Y	$\theta = \phi = 0^\circ$	0.133	0.153	0.173	
0.123				0.143	0.163		
14.8				17.8	20.8		
NTSC			-	50%	-		

Note 1. Ambient condition : $25^\circ\text{C} \pm 2^\circ\text{C}$, $60 \pm 10\% \text{RH}$, under 10 Lux in the darkroom .

Note 2. Measure device : BM-5A (TOPCON) , viewing cone= 1° , $I_L=20\text{mA}$.

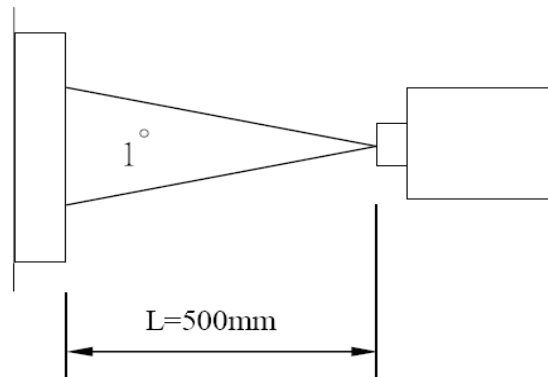

Note 3. Definition of Contrast Ratio :

$$CR = \text{White Luminance (ON)} / \text{Black Luminance (OFF)}$$

Note 4. Definition of response time : The response time is defined as the time interval between the 10% and 90% amplitudes.

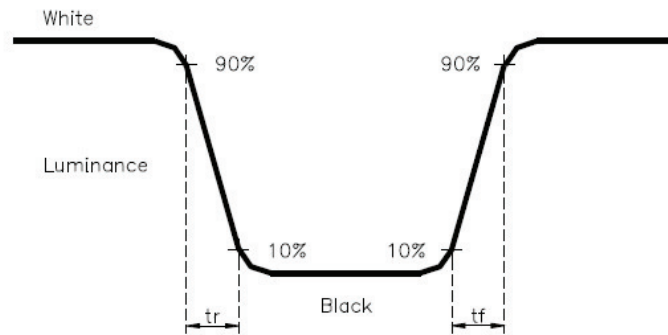

Note 5. Definition of view angle(θ , ψ) :

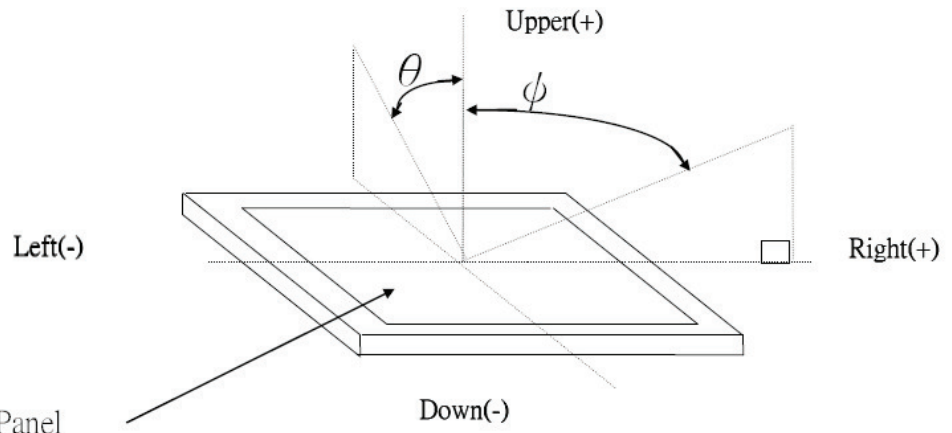

Note 6. Light source: C light.



Doc.No.: AFY800480A0-5.0N6NTN-C

REV : A0

PAGE : 20/21

EFFECTIVE DATE : 2014-07-20

8. Reliability

Please download details at <http://www.orientdisplay.com/Reliability.html>

9. Specification of Quality Assurance

Please download details at <http://www.orientdisplay.com/Delivery-TFT.html>

10. General Precautions

Please download details at <http://www.orientdisplay.com/General-Precautions.html>

11. Limited Warranty

Please download details at <http://www.orientdisplay.com/Warranty.html>

12. Package

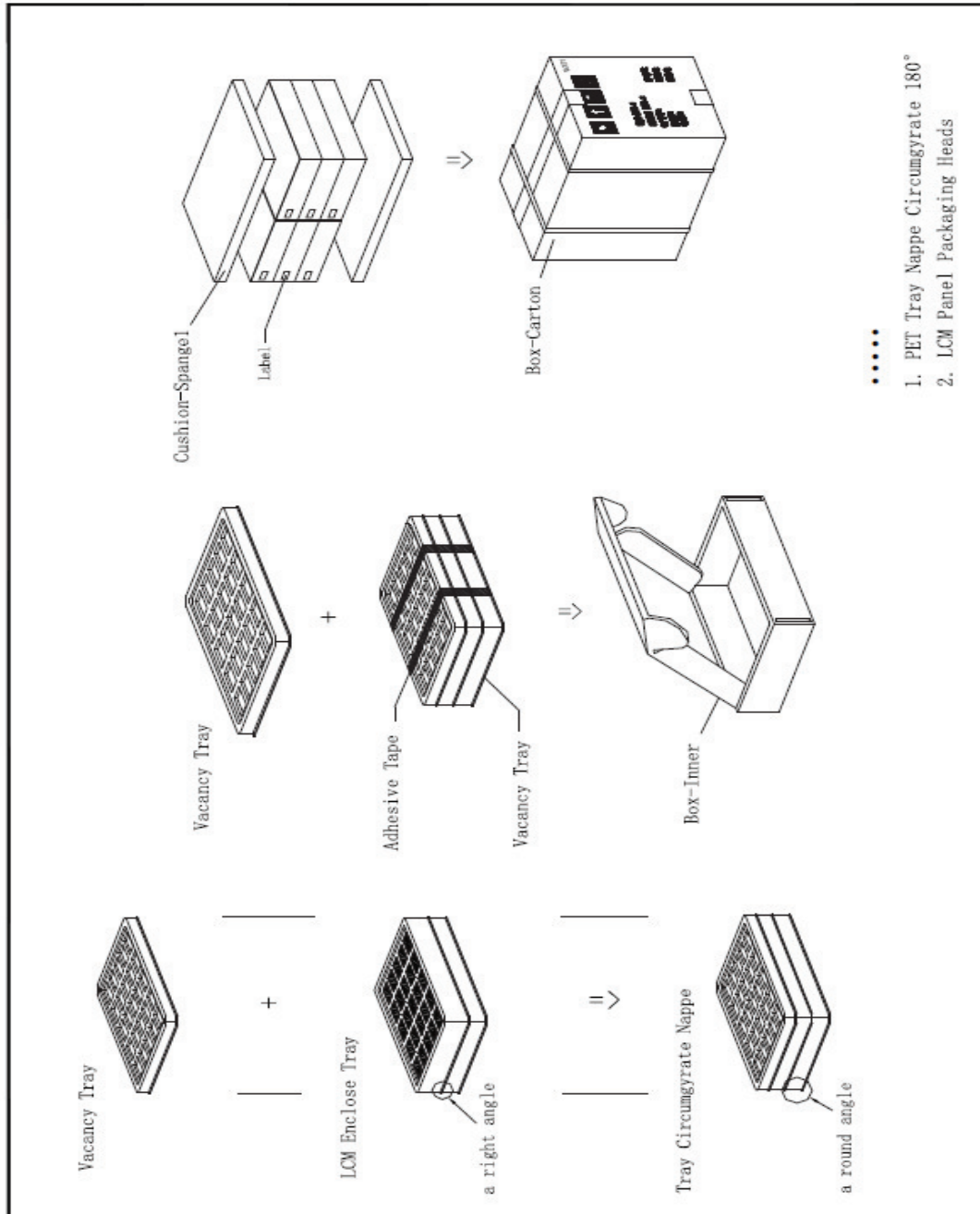

Orient Display Corporation reserves the right to change this specification.