



**SPECIFICATION
FOR
LCD MODULE**

**MODULE NO: AFY240320A0-2.8INTH-C
REVISION NO: D**

Customer's Approval:

--

	SIGNATURE	DATE
PREPARED BY (RD ENGINEER)		
CHECKED BY		
APPROVED BY		

REVISION RECORD

Rev No.	Rev date	Contents	Remarks
O	2019-12-04	First release	Preliminary
A	2020-01-03	CHANGED LENS IN GAGE OF 6TH.	
B	2020-01-07	CHANGED LENS IN GAGE OF 6TH.	
C	2020-01-14	CHANGED CTP PIN DEFINE IN GAGE OF 5&8TH.	
D	2020-03-09	CHANGED PROTECTED FILM AND LENS V.A. Detial as in pages of 6 th .	

CONTENTS

1. GENERAL INFORMATION	3
2. ABSOLUTE MAXIMUM RATINGS.....	3
3. ELECTRICAL CHARACTERISTICS.....	4
4. BACKLIGHT CHARACTERISTICS	4
5. TOUCH PANEL CHARACTERISTICS.....	4
6. EXTERNAL DIMENSIONS	5
7. ELECTRO-OPTICAL CHARACTERISTICS.....	6
8. INTERFACE DESCRIPTION.....	8
9. AC CHARACTERISTICS	9
10. POWER SEQUENCE.....	15
11. RELIABILITY TEST CONDITIONS	16
12. INSPECTION CRITERION.....	17
13. HANDLING PRECAUTIONS	17
14. PRECAUTION FOR USE.....	18
15. PACKING SPECIFICATION.....	18
16. INITIALIZATION CODE	18
17. HSF COMPLIANCE	19

1. GENERAL INFORMATION

No.	Item	Contents	Unit
1	LCD size	2.8 inch (Diagonal)	/
2	Display mode	Normally black/Transmissive/Anti-glare	/
3	Viewing direction(eye)	FREE	/
4	Gray scale inversion direction	-	/
5	Resolution(H*V)	240 *320 Pixels	/
6	Module size (L*W*H)	50.45*69.90*4.21	mm
7	Active area (L*W)	43.20*57.60	mm
8	Pixel pitch (L*W)	0.180*0.180	mm
9	Interface type	RGB interface/SPI/MCU	/
10	Color Depth	16.7M	/
11	Module power consumption	TBD	W
12	Back light type	LED	/
13	Driver IC	TFT ST7789V or compatible CTP ST1633	/
14	Weight	TBD	g

2. ABSOLUTE MAXIMUM RATINGS

Item	Symbol	Min.	Max.	Unit	Note
Power supply input voltage for TFT	VDD	-0.3	4.6	V	
Power supply input voltage for CTP	VCC	-0.3	3.6	V	
Backlight current (normal temp.)	ILED	-	125	mA	
Operation temperature	Top	-20	+70	°C	Note1
Storage temperature	Tst	-30	+80	°C	Note1
Humidity	RH	-	90%(Max60 °C)	RH	Note1

Note1 :

- 1).The relative humidity and temperature range are as below sketch,90%RH Max.
- 2).The maximum wet bulb temperature $\leq 40^{\circ}\text{C}$ and without dewing.

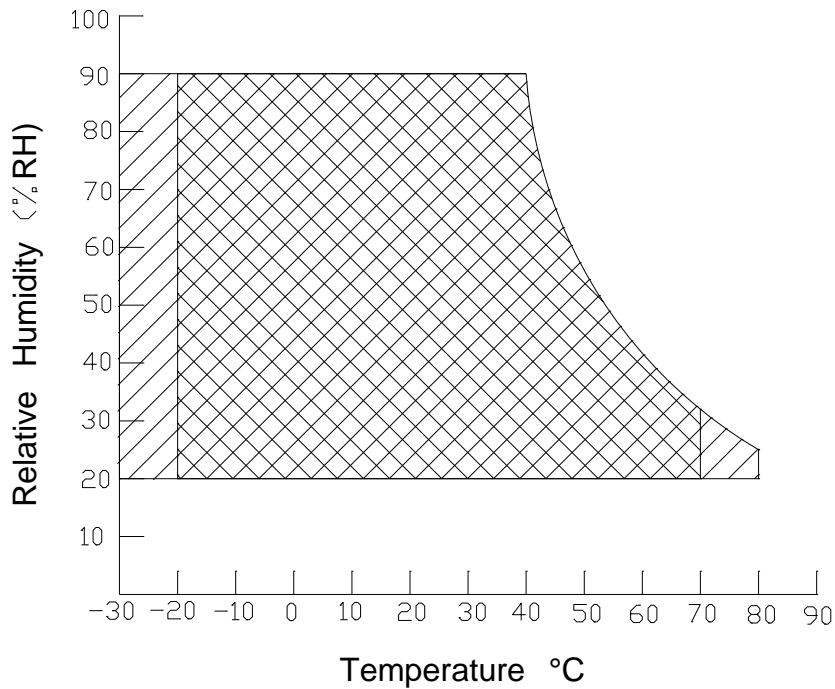

Operating Range  Storage Range  + 

3. ELECTRICAL CHARACTERISTICS

DC CHARACTERISTICS(at Ta=25°C)

Item	Symbol	Min.	Typ.	Max.	Unit	Note
Power supply input voltage	VCC	2.8	3.3	3.6	V	
I/O logic voltage	VDDIO	-	-	-	V	=VCC
Input voltage 'H' level	VIH	0.7VDDIO	-	VDDIO	V	
Input voltage 'L' level	VIL	VSS	-	0.3VDDIO	V	
Power supply current	IVDD	-	TBD	-	mA	

CTP DC CHARACTERISTICS(at Ta=25°C)

Item	Symbol	Min.	Typ.	Max.	Unit	Note
Power supply input voltage	VCC	2.7	3.3	3.6	V	Note2
Input Power ripple	Vpp	-	-	50	mV	
I/O Signal Voltage	VDDIO	-	-	-	V	Note2
Input voltage 'H' level	VIH	0.7VCCIO	-	VCCIO	V	
Input voltage 'L' level	VIL	VSS	-	0.3VCCIO	V	
Operating Current (Normal Mode)	IVCC	-	-	-	mA	
Operating Current (Sleep mode)	IVCC	-	-	-	mA	

Note2 : If you need more information of CTP,please refer to our Spec of CTP.

4. BACKLIGHT CHARACTERISTICS

(at Ta=25°C,RH=60%)

Item	Symbol	Min.	Typ.	Max.	Unit	Note
LED forward voltage	VF	5.8	6.0	6.4	V	IF=20*4mA
LED forward current	IF	-	100	-	mA	
LED power consumption	PLED	-	0.60	-	W	Note1
Number of LED	-		5		PCS	
Connection mode	-	5 in parallel			/	
LED life-time	-	20000	-	-	Hrs	Note2

Note1 : Calculator value for reference : IF*VF = PLED

Note2 : The LED life-time define as the estimated time to 50% degradation of initial brightness at Ta=25°C and IF =100mA. The LED lifetime could be decreased if operating IF is larger than 100mA.

5. TOUCH PANEL CHARACTERISTICS

(at Ta=25°C)

Item	Description	Remark
ProductStructure	G+G	
Surface Hardness	≤6H	Pencil, Loading 500g, 45 deg
Ball-falling Test	≤100cm	Steel ball weight 64g
Touch Count Max	5 points	
I2C Slave Address*	0x55	
Origin of Coordinate*	top left corner	
FW version		

6. EXTERNAL DIMENSIONS

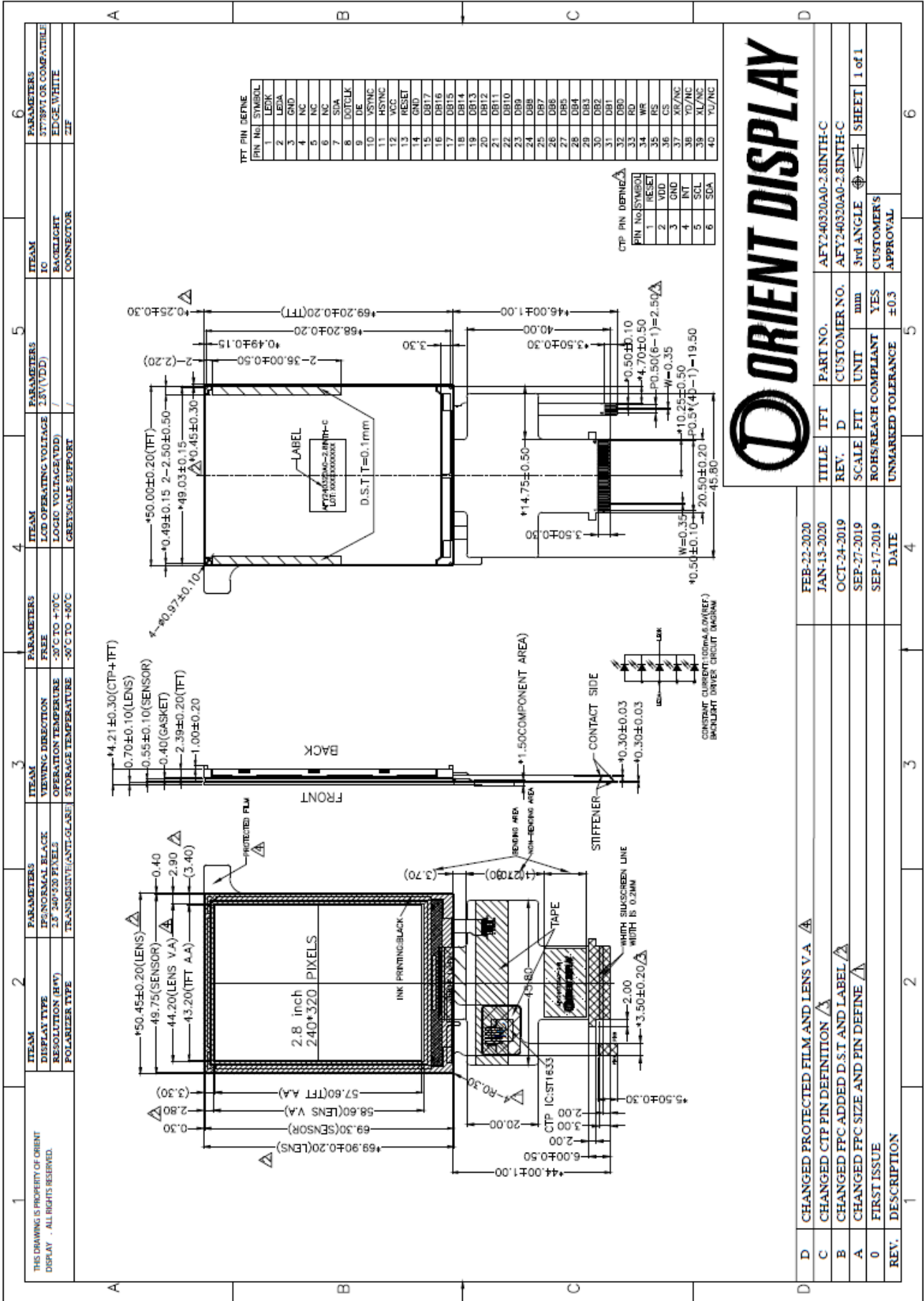

7. ELECTRO-OPTICAL CHARACTERISTICS

Item	Symbol	Condition	Min.	Typ.	Max.	Unit	Remark	Note
Response time	Tr+ Tf	-	-	30	40	ms	FIG.1	Note 1
Contrast ratio	Cr		450	600	-	-	FIG.2	Note 2
Surface luminance	Lv	$\theta=0^\circ$	600	900	-	cd/m ²	FIG.2	Note 3
Luminance uniformity	Yu	$\theta=0^\circ$	75	80	-	%	FIG.2	Note 4
NTSC	-	$\theta=0^\circ$	-	60	-	%	FIG.2	Note 5
Viewing angle	θ	$\varnothing=90^\circ$	70	80	-	deg	FIG.3	Note 6
		$\varnothing=270^\circ$	70	80	-	deg	FIG.3	
		$\varnothing=0^\circ$	70	80	-	deg	FIG.3	
		$\varnothing=180^\circ$	70	80	-	deg	FIG.3	
CIE (x,y) chromaticity	Red x	$\theta=0^\circ$ $\varnothing=0^\circ$ $T_a=25^\circ\text{C}$	Typ -0.04	TBD	Typ +0.04	-	FIG.2 CIE1931	Note 5
	Red y			TBD		-		
	Green x			TBD		-		
	Green y			TBD		-		
	Blue x			TBD		-		
	Blue y			TBD		-		
	White x			TBD		-		
	White y			TBD		-		

Note1. Definition of response time

The response time is defined as the LCD optical switching time interval between "White" state and "Black" state. Rise time (T_{ON}) is the time between photo detector output intensity changed from 90% to 10%. And fall time (T_{OFF}) is the time between photo detector output intensity changed from 10% to 90%. For additional information see FIG1.

Note2. Definition of contrast ratio

Contrast ratio (Cr) is defined mathematically by the following formula. For more information see FIG.2.

$$\text{Contrast ratio} = \frac{\text{Luminance measured when LCD on the "White" state}}{\text{Luminance measured when LCD on the "Black" state}}$$

Measured at the center area of the LCD

Note3. Definition of surface luminance

Surface luminance is the luminance with all pixels displaying white. For more information see FIG.2.

$$L_v = \text{Average Surface Luminance with all white pixels (P1, P2, P3, \dots, P_n)}$$

Note4. Definition of luminance uniformity

The luminance uniformity in surface luminance is determined by measuring luminance at each test position 1 through n, and then dividing the maximum luminance of n points luminance by minimum luminance of n points luminance. For more information see FIG.2.

$$Y_u = \frac{\text{Minimum surface luminance with all white pixels (P1, P2, P3, \dots, P_n)}}{\text{Maximum surface luminance with all white pixels (P1, P2, P3, \dots, P_n)}}$$

Note5. Definition of color chromaticity (CIE1931)

CIE (x,y) chromaticity, The x,y value is determined by screen active area center position P5. For more information see FIG.2.

Note6. Definition of viewing angle

Viewing angle is the angle at which the contrast ratio is greater than 10. angles are determined for the horizontal or x axis and the vertical or y axis with respect to the z axis which is normal to the LCD surface. For more information see FIG.3.

For viewing angle and response time testing, the testing data is base on Autronic-Melchers's ConoScope or DMS series Instruments or compatible. For contrast ratio, Surface Luminance, Luminance uniformity and CIE, the testing data is base on TOPCON's BM-5 or BM-7 photo detector or compatible.

FIG.1. The definition of response Time

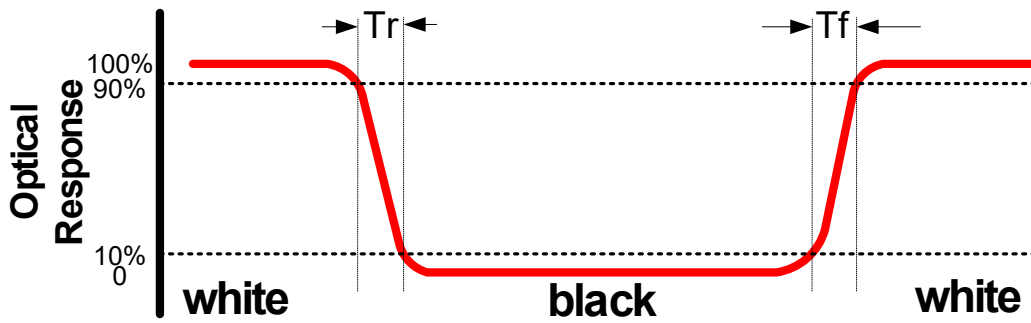

FIG.2. Measuring method for contrast ratio, surface luminance, luminance uniformity, CIE (x,y) chromaticity

H,V : Active area

Light spot size $\varnothing=5\text{mm}$ (BM-5) or $\varnothing=7.7\text{mm}$ (BM-7)50cm distance or compatible distance from the LCM surface to detector lens.

Test spot position : see Figure a.

measurement instrument : TOPCON's luminance meter BM-5 or BM-7 or compatible ,see Figure b.

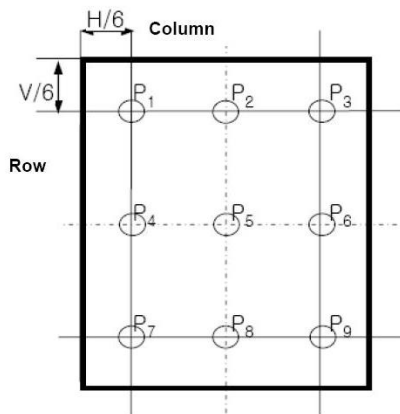

Figure a

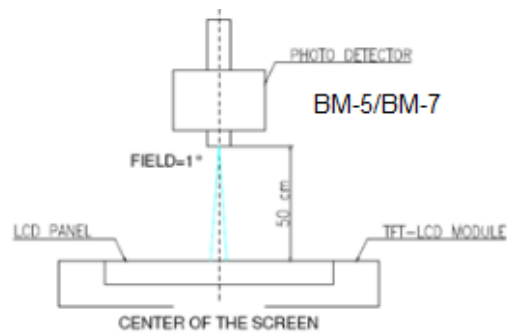
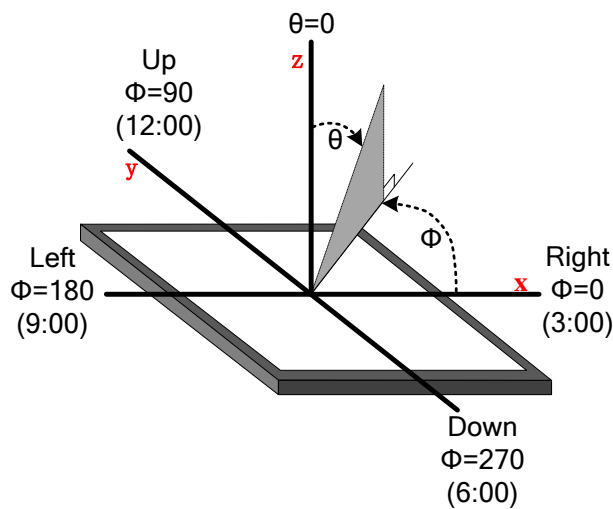

Figure b

FIG.3. The definition of viewing angle



8. INTERFACE DESCRIPTION

Module Interface description

Interface No.	Name	I/O or connect to	Description
1	LEDK	P	Power for LED backlight(Cathode).
2	LEDA	P	Power for LED backlight(Anode).
3	GND	P	Power Ground.
4	NC	/	
5	NC	/	
6	NC	/	
7	SDA	I/O	SPI data input pin.
8	DOTCLK	I	Dot clock signal.
9	DE	I	Data enable.
10	VSYNC	I	Vertical sync input
11	HSYNC	I	Horizontal sync input
12	VCC	P	Power supply
13	RESET	I	Reset signal.
14	GND	P	Power Ground.
15-32	DB17-DB0	I/O	Data bus (DB17--DB0).
33	RD	I	RGB Interface.please fix this pin at VCC or DGND.
34	WR	I	RGB Interface.please fix this pin at VCC or GND.
35	RS	I	RGB Interface. serial interface clock.
36	CS	I	Chip selection pin. Low enable.
37	XR(NC)	/	X-Right
38	YD(NC)	/	Y-Up
39	XL(NC)	/	X-Left
40	YU(NC)	/	Y-Bottom

CTP interface description

Interface No.	Name	I/O or connect to	Description
1	RESET	P	Reset low
2	VDD	P	Power Supply of CTP
3	GND	I	Ground
4	INT	I	State change interrupt
5	SCL	I	Serial interface clock
6	SDA	I/O	Serial interface date

9. AC CHARACTERISTICS

Display Parallel 18/16/9/8-bit Interface Timing Characteristics (8080)

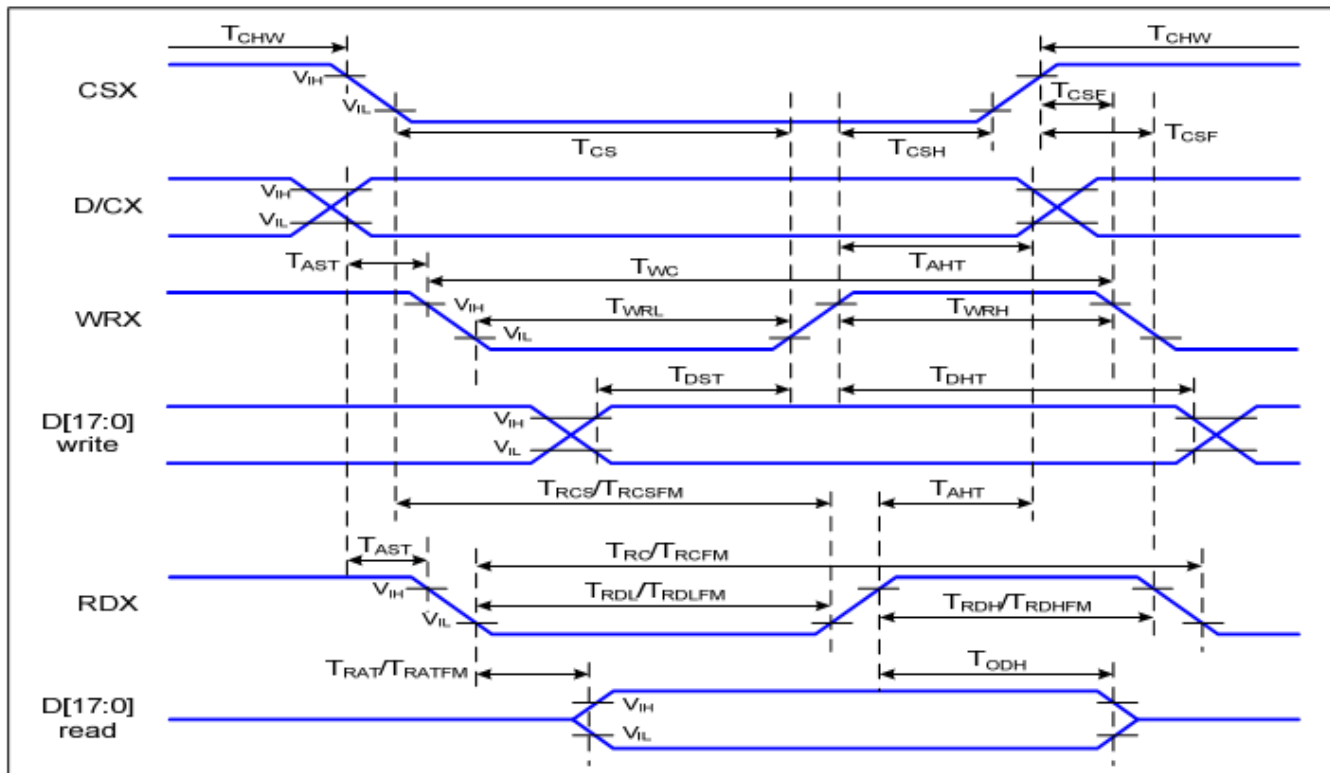

Figure 1 Parallel Interface Timing Characteristics (8080-Series MCU Interface)

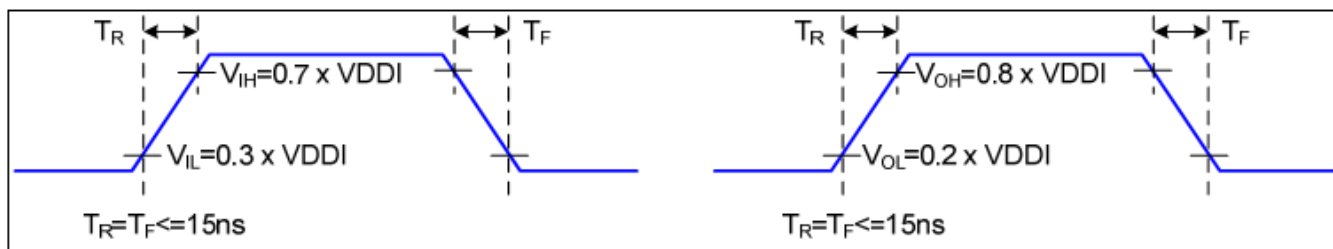

Figure 2 Rising and Falling Timing for I/O Signal

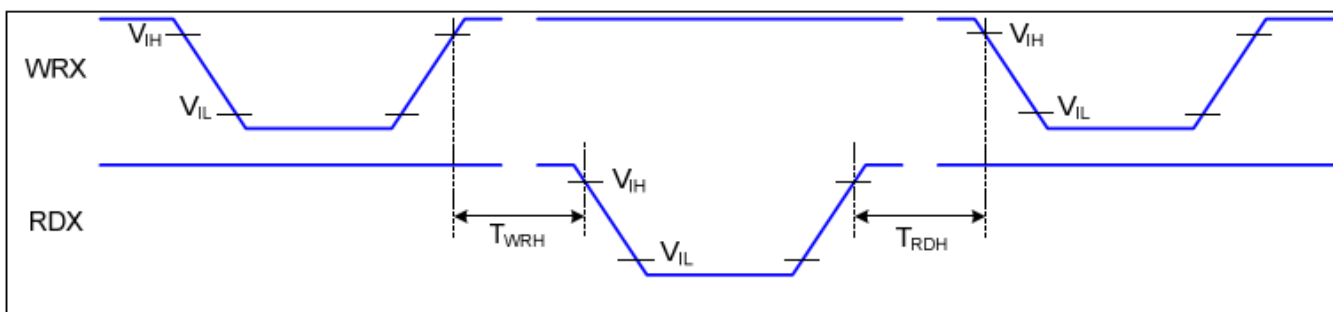

Figure 3 Write-to-Read and Read-to-Write Timing

Signal	Symbol	Parameter	Min	Max	Unit	Description
D/CX	T _{AST}	Address setup time	0		ns	-
	T _{AHT}	Address hold time (Write/Read)	10		ns	
CSX	T _{CHW}	Chip select "H" pulse width	0		ns	-
	T _{CS}	Chip select setup time (Write)	15		ns	
	T _{RCS}	Chip select setup time (Read ID)	45		ns	
	T _{RCSFM}	Chip select setup time (Read FM)	355		ns	
	T _{CSF}	Chip select wait time (Write/Read)	10		ns	
	T _{CSH}	Chip select hold time	10		ns	
WRX	T _{WC}	Write cycle	66		ns	
	T _{WRH}	Control pulse "H" duration	15		ns	
	T _{WRL}	Control pulse "L" duration	15		ns	
RDX (ID)	T _{RC}	Read cycle (ID)	160		ns	When read ID data
	T _{RDH}	Control pulse "H" duration (ID)	90		ns	
	T _{RDL}	Control pulse "L" duration (ID)	45		ns	
RDX (FM)	T _{RCFM}	Read cycle (FM)	450		ns	When read from frame memory
	T _{RDHFM}	Control pulse "H" duration (FM)	90		ns	
	T _{RDLFM}	Control pulse "L" duration (FM)	355		ns	
D[17:0]	T _{DST}	Data setup time	10		ns	For CL=30pF
	T _{DHT}	Data hold time	10		ns	
	T _{RAT}	Read access time (ID)		40	ns	
	T _{RATFM}	Read access time (FM)		340	ns	
	T _{ODH}	Output disable time	20	80	ns	

Display Serial Interface Timing Characteristics (3-line SPI system)

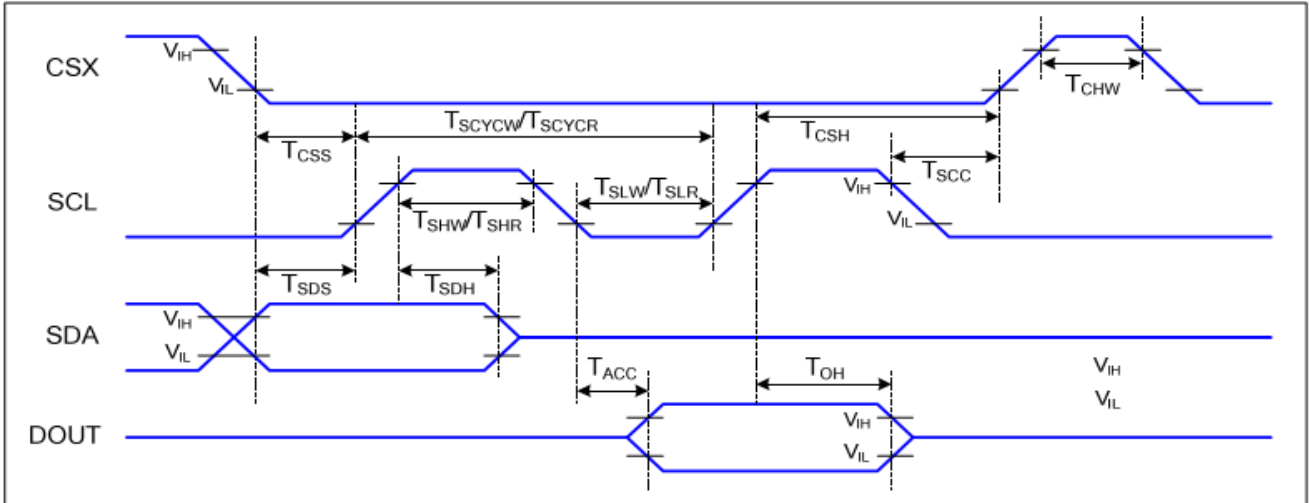

Figure 4 3-line serial Interface Timing Characteristics

VDDI=1.65 to 3.3V, VDD=2.4 to 3.3V, AGND=DGND=0V, Ta=-30 to 70 °C

Signal	Symbol	Parameter	Min	Max	Unit	Description
CSX	T _{CSS}	Chip select setup time (write)	15		ns	
	T _{CSH}	Chip select hold time (write)	15		ns	
	T _{CSS}	Chip select setup time (read)	60		ns	
	T _{SCC}	Chip select hold time (read)	65		ns	
	T _{CHW}	Chip select "H" pulse width	40		ns	
SCL	T _{SCYCW}	Serial clock cycle (Write)	66		ns	
	T _{SHW}	SCL "H" pulse width (Write)	15		ns	
	T _{SLW}	SCL "L" pulse width (Write)	15		ns	
	T _{SCYCR}	Serial clock cycle (Read)	150		ns	
	T _{SHR}	SCL "H" pulse width (Read)	60		ns	
	T _{SLR}	SCL "L" pulse width (Read)	60		ns	
SDA (DIN)	T _{SDS}	Data setup time	10		ns	
	T _{SDH}	Data hold time	10		ns	
DOUT	T _{ACC}	Access time	10	50	ns	For maximum CL=30pF
	T _{OH}	Output disable time	15	50	ns	For minimum CL=8pF

Table 5 3-line serial Interface Characteristics

Display Serial Interface Timing Characteristics (4-line SPI system)

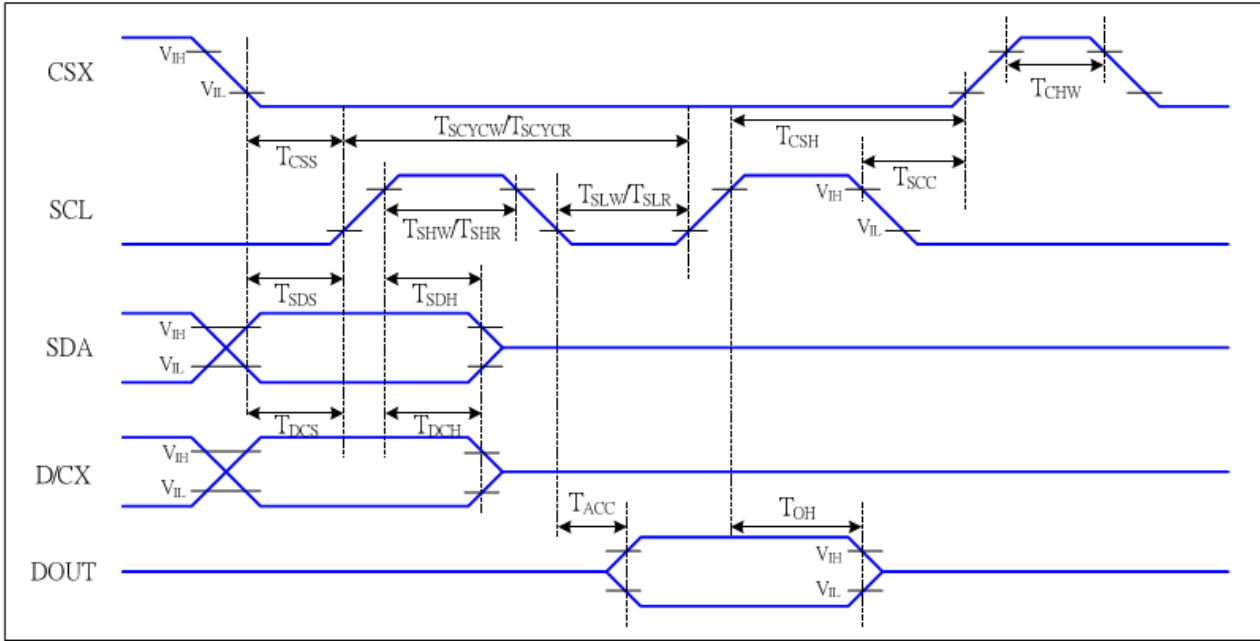

Figure 5 4-line serial Interface Timing Characteristics

$V_{DDI}=1.65$ to $3.3V$, $V_{DD}=2.4$ to $3.3V$, $AGND=DGND=0V$, $T_a=-30$ to 70 °C

Signal	Symbol	Parameter	MIN	MAX	Unit	Description
CSX	T_{CSS}	Chip select setup time (write)	15		ns	
	T_{CSH}	Chip select hold time (write)	15		ns	
	T_{CSS}	Chip select setup time (read)	60		ns	
	T_{SCC}	Chip select hold time (read)	65		ns	
	T_{CHW}	Chip select "H" pulse width	40		ns	
SCL	T_{SCYCW}	Serial clock cycle (Write)	66		ns	-write command & data ram
	T_{SHW}	SCL "H" pulse width (Write)	15		ns	
	T_{SLW}	SCL "L" pulse width (Write)	15		ns	
	T_{SCYCR}	Serial clock cycle (Read)	150		ns	-read command & data ram
	T_{SHR}	SCL "H" pulse width (Read)	60		ns	
	T_{SLR}	SCL "L" pulse width (Read)	60		ns	
D/CX	T_{DCS}	D/CX setup time	10		ns	
	T_{DCH}	D/CX hold time	10		ns	
SDA (DIN)	T_{SDS}	Data setup time	10		ns	
	T_{SDH}	Data hold time	10		ns	
DOUT	T_{ACC}	Access time	10	50	ns	For maximum $CL=30pF$
	T_{OH}	Output disable time	15	50	ns	For minimum $CL=8pF$

Table 6 4-line serial Interface Characteristics

RGB Interface Characteristics:

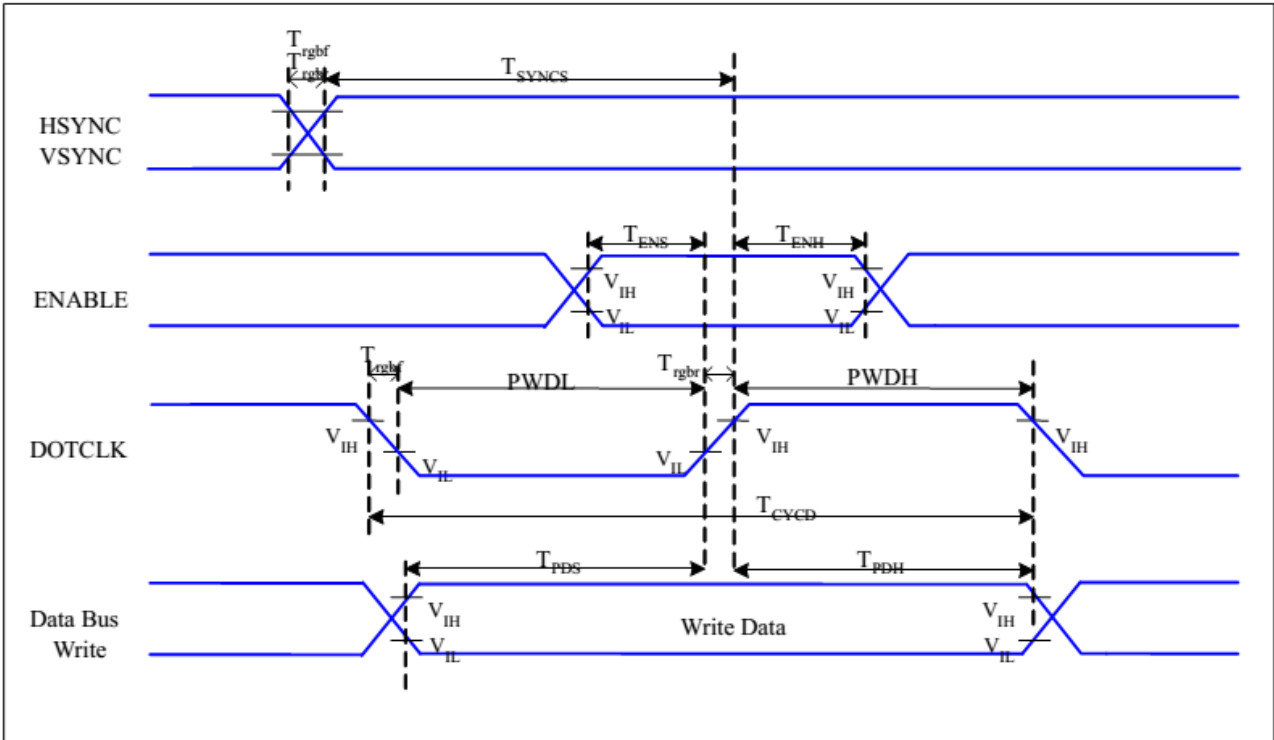

Figure 6 RGB Interface Timing Characteristics

VDDI=1.65 to 3.3V, VDD=2.4 to 3.3V, AGND=DGND=0V, Ta=-30 ~ 70 °C

Signal	Symbol	Parameter	MIN	MAX	Unit	Description
HSYNC, VSYNC	T_{SYNCS}	VSYNC, HSYNC Setup Time	30	-	ns	
ENABLE	T_{ENS}	Enable Setup Time	25	-	ns	
	T_{ENH}	Enable Hold Time	25	-	ns	
DOTCLK	PWDH	DOTCLK High-level Pulse Width	60	-	ns	
	PWDL	DOTCLK Low-level Pulse Width	60	-	ns	
	T_{CYCD}	DOTCLK Cycle Time	120	-	ns	
	Trghr, Trghf	DOTCLK Rise/Fall time	-	20	ns	
DB	T_{PDS}	PD Data Setup Time	50	-	ns	
	T_{PDH}	PD Data Hold Time	50	-	ns	

Table 7 18/16 Bits RGB Interface Timing Characteristics

CTP AC CHARACTERISTICS

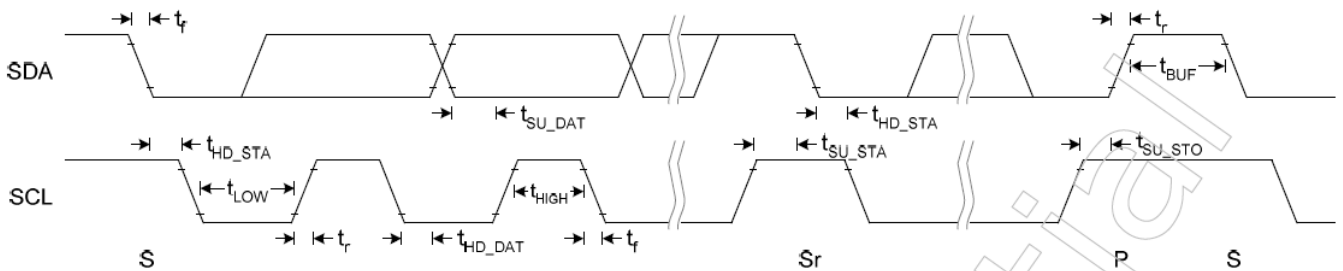

Figure.7 I2C Fast Mode Timing

Conditions: VDD = 3.3V, GND = 0V, T_A = 25°C

Symbol	Parameter	Rating			Unit
		Min.	Typ.	Max.	
f _{SCL}	SCL clock frequency	0	-	400	kHz
t _{LOW}	Low period of the SCL clock	1.3	-	-	us
t _{HIGH}	High period of the SCL clock	0.6	-	-	us
t _f	Signal falling time	-	-	300	ns
t _r	Signal rising time	-	-	300	ns
t _{SU_STA}	Set up time for a repeated START condition	0.6	-	-	us
t _{HD_STA}	Hold time (repeated) START condition. After this period, the first clock pulse is generated	0.6	-	-	us
t _{SU_DAT}	Data set up time	100	-	-	ns
t _{HD_DAT}	Data hold time	0	-	0.9	us
t _{SU_STO}	Set up time for STOP condition	0.6	-	-	us
t _{BUF}	Bus free time between a STOP and START condition	1.3	-	-	us
C _b	Capacitive load for each bus line	-	-	400	pF

Table 8. I2C Fast Mode Timing Characteristic

10. POWER SEQUENCE

10.1 TFT Power On/Off Sequence

VDDI and VDD can be applied in any order.

VDD and VDDI can be power down in any order.

During power off, if LCD is in the Sleep Out mode, VDD and VDDI must be powered down minimum 120msec after RESX has been released.

During power off, if LCD is in the Sleep In mode, VDDI or VDD can be powered down minimum 0msec after RESX has been released.

CSX can be applied at any timing or can be permanently grounded. RESX has priority over CSX.

Note 1: There will be no damage to the display module if the power sequences are not met.

Note 2: There will be no abnormal visible effects on the display panel during the Power On/Off Sequences.

Note 3: There will be no abnormal visible effects on the display between end of Power On Sequence and before receiving Sleep Out command. Also between receiving Sleep In command and Power Off Sequence.

Note 4: If RESX line is not held stable by host during Power On Sequence as defined in the sequence below, then it will be necessary to apply a Hardware Reset (RESX) after Host Power On Sequence is complete to ensure correct operation. Otherwise function is not guaranteed.

The power on/off sequence is illustrated below

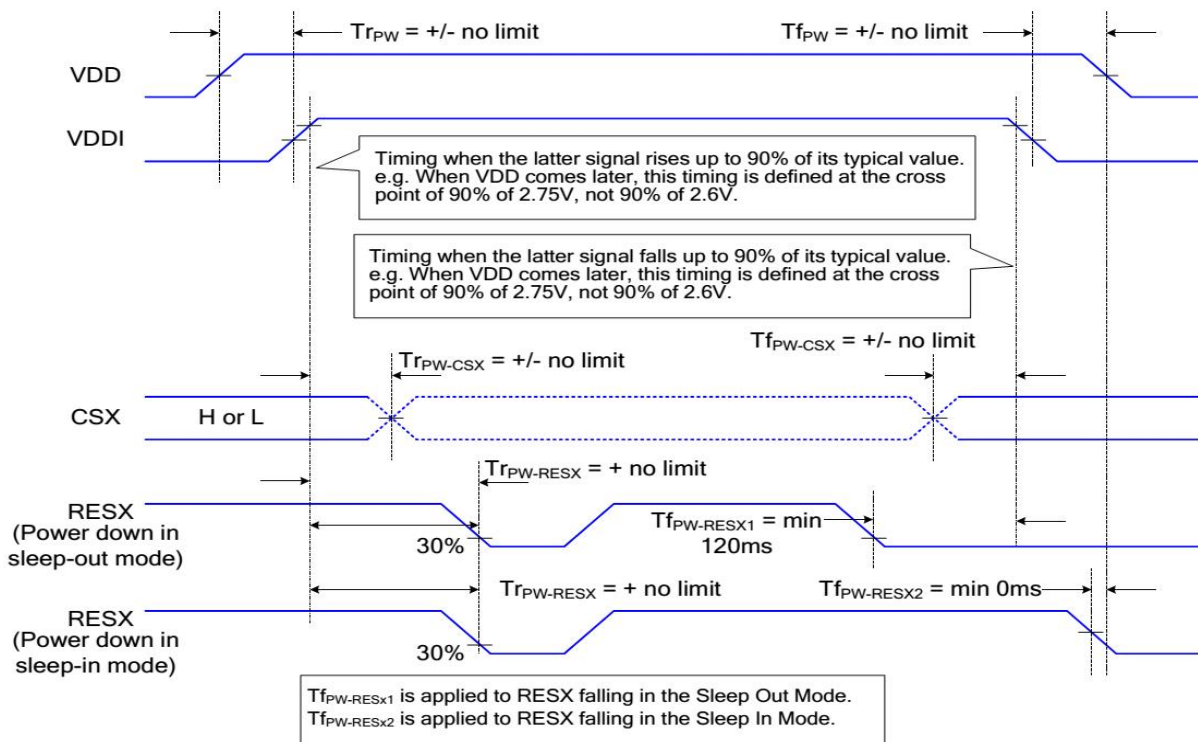

10.2 CTP Power On/Off Sequence

RESET pin should be held low before power on and power off. During power on, after both VDD and IOVDD reach normal voltage, RESET pin needs to be held low for 5ms to ensure internal block stable.

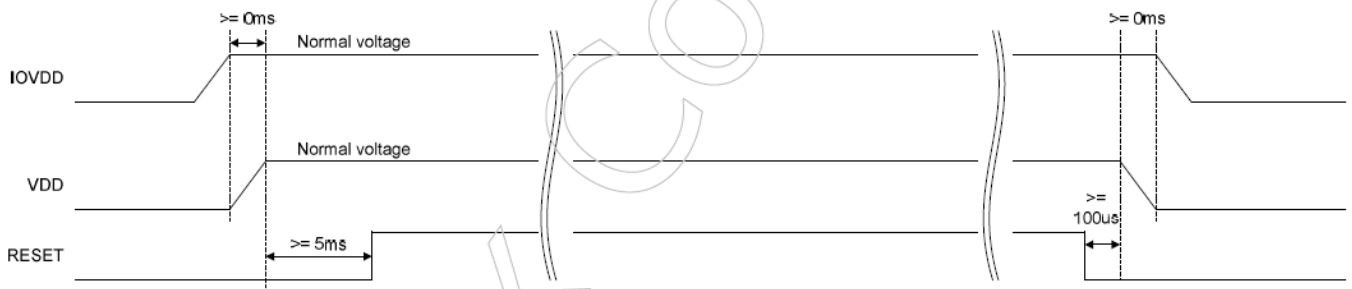

11. RELIABILITY TEST CONDITIONS

No.	Test item	Test condition	Inspection after test	
11.1	High temperature storage test	+80°C/240 hours	Inspection after 2~4hours storage at room temperature, the sample shall be free from defects : 1.Current changing value before test and after test is 50% larger; 2. Function defect : Non-display,abnormal-d isplay,missing lines, Short lines,ITO corrosion; 3.Visual defect : Air bubble in the LCD,Seal leak,Glass crack.	
11.2	Low temperature storage test	-30°C/240 hours		
11.3	High temperature operating test	+70°C/120 hours		
11.4	Low temperature operating test	-20°C/120 hours		
11.5	Temperature cycle storage test	-30°C ~ 25°C ~ +80°C/10cycles (30min.) (10min.) (30min.)		
11.6	High temperature high humidity test	+50°C*90% RH/120 hours		
11.7	Vibration test	Frequency : 250 r/min Amplitude : 1 inch Time: 45min		
11.8	Drop test	Drop direction: 1 corner/3 edges/6 sides 10 time		
		Packing weight(kg)		Drop height(cm)
		<11		80±1.6
		11≤G<21	60±1.2	
		21≤G<31	50±1.0	
		31≤G<40	40±0.8	
11.9	ESD test	Air discharge: ±8KV, 10time Contact discharge: ±4KV, 10time		
Remark : 1.The test samples should be applied to only one test item. 2.Sample size for each test item is 3~5pcs. 3.For High temperature high humidity test, Pure water(Resistance>10MΩ) should be used. 4.In case of malfunction defect caused by ESD damage, if it would be recovered to normal state after resetting, it would be judged as a good part. 5.B/L evaluation should be excepted from reliability test with humidity and temperature: Some defects such as black spot/blemish can happen by natural chemical reaction with humidity and Fluorescence B/L has. 6.Failure judgment criterion: Basic specification, Electrical characteristic, Mechanical characteristic, Optical characteristic.				

12.INSPECTION CRITERION

Refer to 《Inspection Criterion for TFT Products》 V2.3.

13. HANDLING PRECAUTIONS

13.1 Mounting method

The LCD module consists of two thin glass plates with polarizers which easily be damaged. And since the module is so constructed as to be fixed by utilizing fitting holes in the printed circuit board.

Extreme care should be needed when handling the LCD modules.

13.2 Caution of LCD handling and cleaning

When cleaning the display surface, Use soft cloth with solvent [recommended below] and wipe lightly :

- .Isopropyl alcohol
- .Ethyl alcohol

Do not wipe the display surface with dry or hard materials that will damage the polarizer surface.

Do not use the following solvent :

- .Water
- .Aromatics

Do not wipe ITO pad area with the dry or hard materials that will damage the ITO patterns

Do not use the following solvent on the pad or prevent it from being contaminated :

- .Soldering flux
- .Chlorine (Cl) , Sulfur (S)

If goods were sent without being silicon coated on the pad, ITO patterns could be damaged due to the corrosion as time goes on.

If ITO corrosion happens by miss-handling or using some materials such as Chlorine (Cl), Sulfur (S) from customer, Responsibility is on customer.

13.3 Caution against static charge

The LCD module uses C-MOS LSI drivers, so we recommend that you :

Connect any unused input terminal to Vdd or Vss, do not input any signals before power is turned on, and ground your body, work/assembly areas, assembly equipment to protect against static electricity.

13.4 Packing

Module employs LCD elements and must be treated as such.

- .Avoid intense shock and falls from a height.
- .To prevent modules from degradation, do not operate or store them exposed direct to sunshine or high temperature/humidity.

13.5 Caution for operation

- .It is an indispensable condition to drive LCD's within the specified voltage limit since the higher voltage than the limit causes the shorter LCD life.
- .An electrochemical reaction due to direct current causes LCD's undesirable deterioration, so that the use of direct current drive should be avoided.
- .Response time will be extremely delayed at lower temperature than the operating temperature range and on the other hand at higher temperature LCD's show dark color in them. However those phenomena do not mean malfunction or out of order with LCD's, which will come back in the specified operation temperature.
- .If the display area is pushed hard during operation, some font will be abnormally displayed but it resumes normal condition after turning off once.
- .A slight dew depositing on terminals is a cause for electro-chemical reaction resulting in terminal open circuit.
- .Usage under the maximum operating temperature, 50%Rh or less is required.
- .When fixed patterns are displayed for a long time, remnant image is likely to occur.

13.6 Storage

In the case of storing for a long period of time for instance, for years for the purpose of replacement use, the following ways are recommended.

- .Storing in an ambient temperature 10°C to 30°C, and in a relative humidity of 45% to 75%. Don't expose to sunlight or fluorescent light.
- .Storing in a polyethylene bag with the opening sealed so as not to enter fresh air outside in it . And with no desiccant.
- .Placing in a dark place where neither exposure to direct sunlight nor light's keeping the storage temperature range.
- .Storing with no touch on polarizer surface by anything else.

It is recommended to store them as they have been contained in the inner container at the time of delivery from

us.

13.7 Safety

- .It is recommendable to crash damaged or unnecessary LCD's into pieces and wash off liquid crystal by either of solvents such as acetone and ethanol, which should be burned up later.
- .When any liquid leaked out of a damaged glass cell comes in contact with your hands, please wash it off well with soap and water.

14. PRECAUTION FOR USE

14.1 A limit sample should be provided by the both parties on an occasion when the both parties agreed its necessity. Judgment by a limit sample shall take effect after the limit sample has been established and confirmed by the both parties.

14.2 On the following occasions, the handing of problem should be decided through discussion and agreement between responsible of the both parties.

- .When a question is arisen in this specification.
- .When a new problem is arisen which is not specified in this specifications.
- .When an inspection specifications change or operating condition change in customer is reported to ODNA, and some problem is arisen in this specification due to the change.
- .When a new problem is arisen at the customer's operating set for sample evaluation in the customer site.

15. PACKING SPECIFICATION

Please consult our technical department for detail information.

16. INITIALIZATION CODE

```
Write(Command , 0x11);
Delay(120);
Write(Command , 0x36);
Write(Parameter , 0x00);
Write(Command , 0x3A);
Write(Parameter , 0x06);
Write(Command , 0xB2);
Write(Parameter , 0x0C);
Write(Parameter , 0x0C);
Write(Parameter , 0x00);
Write(Parameter , 0x33);
Write(Parameter , 0x33);
Write(Command , 0xB7);
Write(Parameter , 0x35); //vgh=13.26 vgl=-12.5
Write(Command , 0xBB);
Write(Parameter , 0x36);
Write(Command , 0xC0);
Write(Parameter , 0x2C);
Write(Command , 0xC2);
Write(Parameter , 0x01);
Write(Command , 0xC3);
Write(Parameter , 0x10);
Write(Command , 0xC4);
Write(Parameter , 0x20);
Write(Command , 0xC6);
Write(Parameter , 0x0F); //60hz
Write(Command , 0xD0);
Write(Parameter , 0xA4);
Write(Parameter , 0xA1);
Write(Command , 0xE0);
Write(Parameter , 0xD0);
Write(Parameter , 0x07);
Write(Parameter , 0x0B);
Write(Parameter , 0x09);
Write(Parameter , 0x07);
```

Write(Parameter , 0x23);
Write(Parameter , 0x24);
Write(Parameter , 0x44);
Write(Parameter , 0x3C);
Write(Parameter , 0x07);
Write(Parameter , 0x0D);
Write(Parameter , 0x11);
Write(Parameter , 0x28);
Write(Parameter , 0x29);
Write(Command , 0xE1);
Write(Parameter , 0xD0);
Write(Parameter , 0x08);
Write(Parameter , 0x09);
Write(Parameter , 0x09);
Write(Parameter , 0x07);
Write(Parameter , 0x24);
Write(Parameter , 0x25);
Write(Parameter , 0x54);
Write(Parameter , 0x3B);
Write(Parameter , 0x07);
Write(Parameter , 0x0C);
Write(Parameter , 0x0E);
Write(Parameter , 0x28);
Write(Parameter , 0x2F);
Write(Command , 0x21);
Write(Command , 0x29);

16.HSF COMPLIANCE

●.This products complies with ROHS 2011/65/EU and 2015/863/EU、REACH 1907/2006/EC requirements, and the packaging complies with 94-62-EC.

这个产品符合 ROHS 2011/65/EU 和 2015/863/EU、REACH 1907/2006/EC 要求，包材符合 94-62-EC 指令要求