



145 Royal Crest Court Unit 42 Markham, ON, Canada L3R 9Z4
Tel: 905-477-1166 Fax: 905-477-1782 <http://www.orientdisplay.com>

SPECIFICATION FOR LCD MODULE

Part No.: AMG320240FR-M-W6WFDW-NV
Rev: B00
Issued Date: 2009-10-14

Engineering Dept				Customer Approved
Prepared		Checked	Approved	
LCD	LCM			
Xiaoli Jin	Weihao Lin	Xichun Wu	Xichun Wu	

Table of Contents

- 1 General Specifications3
- 2 Mechanical Diagram4
- 3 I/O Terminal5
 - 3.1 Pin Description.....5
 - 3.2 Block Diagram6
- 4 Electro-optical Specifications7
 - 4.1 Absolute Maximum Ratings.....7
 - 4.2 Optical Characteristics⁽¹⁾7
 - 4.3 Electrical Characteristics7
 - 4.4 Timing Characteristics8
- 5 Register Table9
- Appendix.....10
 - 1 Packing Method10
 - 2 Classification11
 - 3 Handling precaution for LCM.....11
 - 4 Definitions of Optical Characteristic.....12
 - 4.1 Contrast Ratio Test12
 - 4.2 Response time.....12
 - 4.3 Luminance Measurement.....14
 - 4.4 White Uniformity Measurement.....14
 - 4.5 Viewing Angle A) Viewing angle is definition.....15
- 5 QUALITY UNITS17
 - 5.1 Visual and Technological Inspection17
 - 5.2 Visual Inspection Standard:18
 - 5.3 Display Inspection Standard:19
- 6 Reliability-TEST.....21
 - 6.1 Standard Specifications for Reliability21
 - 6.2 Life Time.....22

Revision History

Rev.	Comment	Date
A00	Original Version	2008-07-20
B00	Update the Electro-optical Specifications etc	2008-08-30

1 General Specifications

Item	<input checked="" type="checkbox"/> Standard Value	Unit
Display Pattern	<input checked="" type="checkbox"/> Graphic <input type="checkbox"/> Character <input type="checkbox"/> Segment <input type="checkbox"/> _____ <input type="checkbox"/> with ICON	
Color	<input type="checkbox"/> Mono. <input checked="" type="checkbox"/> Grayscale <input type="checkbox"/> _____	
Module Dimension (W x H x T)	142.1x106.05x14.5(max)	mm
Viewing Area (W x H)	103x79	mm
Active Area (W x H)	95.97 x71.97	mm
Character Size (W x H)	/	mm
Character Pitch (W x H)	/	mm
DOT Size (W x H)	0.292x0.292	mm
DOT Pitch (W x H)	0.30x0.30	mm
LCD Type	<input type="checkbox"/> TN, Positive <input type="checkbox"/> TN, Negative <input type="checkbox"/> HTN, Positive <input type="checkbox"/> HTN, Negative <input type="checkbox"/> STN, Yellow-Green <input type="checkbox"/> STN, Gray <input type="checkbox"/> STN, Blue <input checked="" type="checkbox"/> FSTN, Positive <input type="checkbox"/> FSTN, Negative <input type="checkbox"/> _____ <input type="checkbox"/> FM LCD <input type="checkbox"/> Color STN	
Polarizer Type	<input checked="" type="checkbox"/> Transflective <input type="checkbox"/> Transmissive <input type="checkbox"/> Reflective <input type="checkbox"/> Anti-Glare	
View Direction	<input checked="" type="checkbox"/> 6H <input type="checkbox"/> 12H <input type="checkbox"/> _____	
LCD Controller & Driver	RA8803S & NT7086	
LCD Driving Method	1/2401duty, 1/14bias	
Interface Type	Serial <input type="checkbox"/> I ² C <input type="checkbox"/> 4-line SPI <input type="checkbox"/> 3-line SPI <input type="checkbox"/> _____ Parallel <input type="checkbox"/> 6800 <input checked="" type="checkbox"/> 8080 <input type="checkbox"/> 4-bit <input type="checkbox"/> _____	
Backlight Type	<input type="checkbox"/> LED <input type="checkbox"/> Bottom <input checked="" type="checkbox"/> Single Side <input type="checkbox"/> Dual Side <input type="checkbox"/> _____ <input type="checkbox"/> EL <input type="checkbox"/> CCFL	
Backlight Color	<input type="checkbox"/> Yellow-Green <input checked="" type="checkbox"/> White <input type="checkbox"/> Amber <input type="checkbox"/> Blue <input type="checkbox"/> Red <input type="checkbox"/> _____	
EL/CCFL Driver type	<input type="checkbox"/> Build-in <input type="checkbox"/> External	
DC-DC Converter	<input type="checkbox"/> Build-in <input checked="" type="checkbox"/> External	
Operation Temperature	T _{OPL} = -20 T _{OPH} = +70	°C
Storage Temperature	T _{STL} = -30 T _{STH} = +80	°C

3 I/O Terminal

3.1 Pin Description

CN1:

Pin NO.	Symbol	Function Description
1	GND	Power Ground
2	VDD	Supply Logic Power
3	NC	No Connection
4	/WR	Write signal
5	/RD	Read signal
6	/CS	Chip Select Signal
7	A0	Selection Display Data or Command
8	/RES	System Reset Signal
9	D0	8-bit bi-directional data bus
10	D1	
11	D2	
12	D3	
13	D4	
14	D5	
15	D6	
16	D7	

CN2:

Pin NO.	Symbol	Function Description
1	LED+	Backlight Anode
2	NC	No Connection
3	NC	No Connection
4	LED-	Backlight Cathode

3.2 Block Diagram

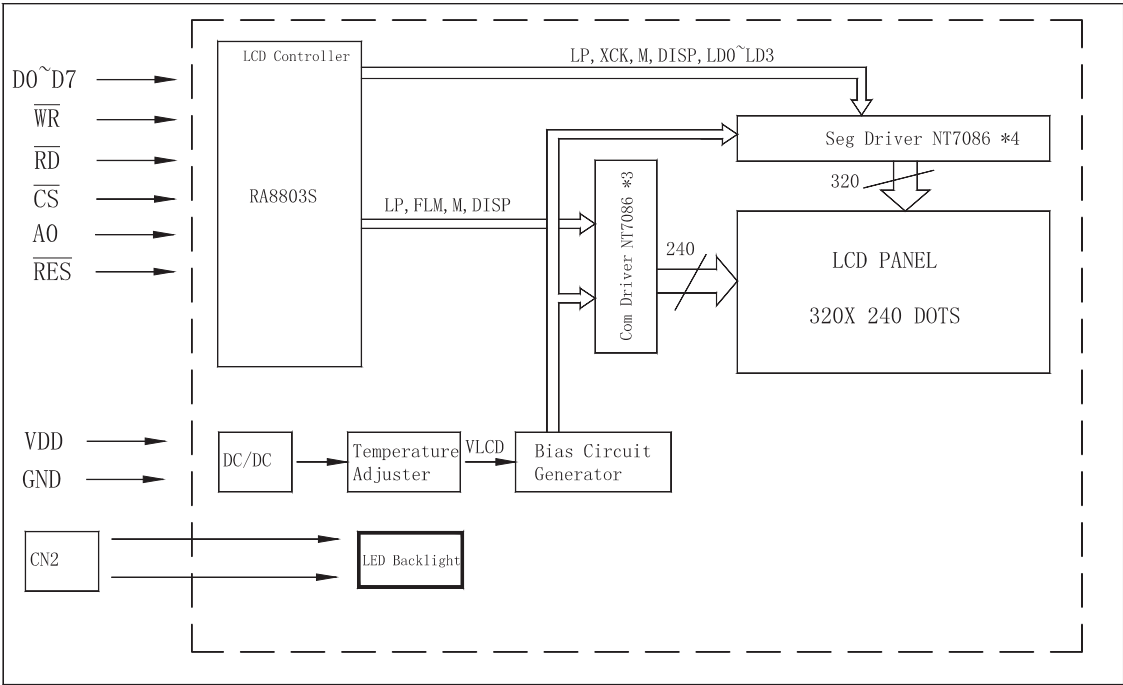

4 Electro-optical Specifications

4.1 Absolute Maximum Ratings

No	Item	Symbol	Min.	Max.	Unit
1	Supply Voltage For Logic	$V_{DD}-V_{SS}$	-0.3	7.0	V
2	Supply Voltage For LCD Driver	V_{LCD}	0	30	V
3	Input Voltage	V_{IN}	-0.3	$V_{DD}+0.3$	V

Note: Operating Temperature and Storage Temperature can be found in 1. General Specifications.

4.2 Optical Characteristics⁽¹⁾

No	Item	Symbol	Condition	Min.	Type.	Max.	Unit	
1	Contrast Ratio	Cr	$T_a=23+3^{\circ}\text{C}$ VLCD = Type. (2)	-	7	-	-	
2	Response time	TR	$T_a=23+3^{\circ}\text{C}$	-	160	-	ms	
3	Response time	TF	$T_a=23+3^{\circ}\text{C}$	-	240	-	ms	
4	Viewing Angle	3H	$\Theta 3$	$Cr \geq 2$ $T_a=23+3^{\circ}\text{C}$	-	50	-	Deg.
		9H	$\Theta 4$		-	40	-	Deg.
		6H	$\Theta 1$		-	40	-	Deg.
		12H	$\Theta 2$		-	40	-	Deg.
5	Module luminance		$T_a=23+3^{\circ}\text{C}$ $I_{led}=150\text{mA}$	-	200	-	cd/m ²	
6	Luminance uniformity	Lu		70	-	-	%	

Note:

(1) See Appendix Definition of Optical Characteristics for detail.

(2) V_{LCD} can be found in 4.2 Electrical Characteristics *Supply Voltage for LCD Driver*

4.3 Electrical Characteristics

No	Item	Symbol	Condition	Min.	Typ.	Max.	Unit
1	Supply Voltage for Logic	$V_{DD}-V_{SS}$	-	4.9	5.0	5.1	V
2	Supply Voltage for LCD Driver	V_{LCD}	$T_a=25^{\circ}\text{C}$	22.8	23	23.2	V
3	Supply Current for Logic	I_{DD}	-....	-	-	50	mA
4	Input High Voltage	V_{IH}	-	$0.8V_{DD}$	-	V_{DD}	V
5	Input Low Voltage	V_{IL}	-	V_{SS}	-	$0.2V_{DD}$	V
6	Output High Voltage	V_{OH}	$I_{OH}=-0.4\text{mA}$	$V_{DD}-0.4$	-	-	V
7	Output Low Voltage	V_{OL}	$I_{OH}=-0.4\text{mA}$	-	-	0.4	V
8	Supply Current for LED Backlight	I_{LED}	$V_{LED} = \text{Type.}$ $T_a=23+3^{\circ}\text{C}$	-	150	-	mA
9	Supply Voltage for LED Backlight	V_{LED}	$I_{LED} = \text{Type.}$ $T_a=23+3^{\circ}\text{C}$	4.8	5.0	5.2	V

4.4 Timing Characteristics

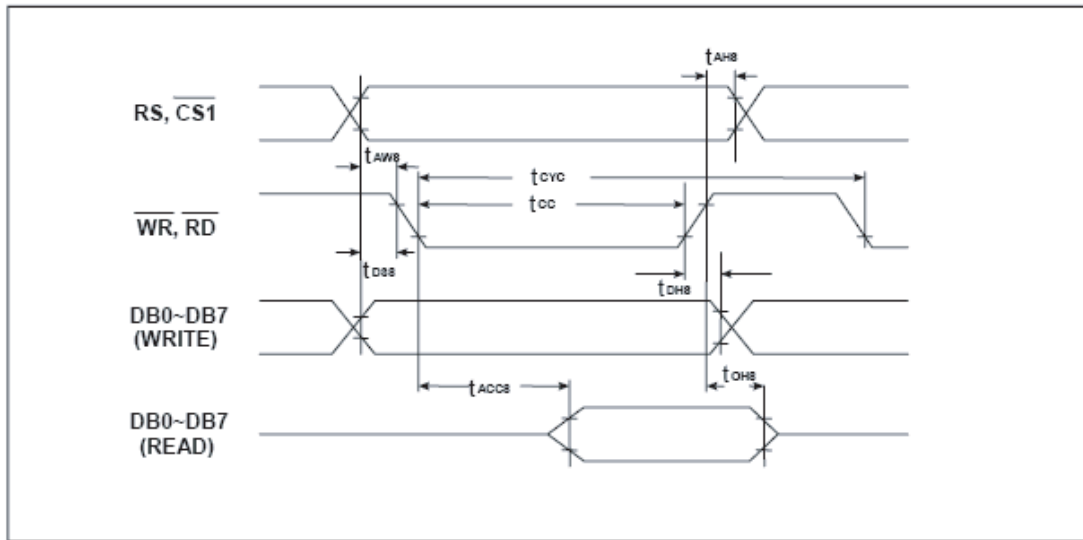

Figure 2-2 : 8-Bit 8080 MPU Access RA8803/8822 Register/Memory

Table 2-1

Signal	Symbol	Parameter	Rating		Unit	Condition
			Min	Max		
RS, CS1#	t_{AH8}	Address hold time	10	--	ns	System Clock: 8MHz Voltage: 3.3V
	t_{AW8}	Address setup time	63	--	ns	
WR#, RD#	t_{CYC}	System cycle time	800	--	ns	
	t_{CC}	Strobe pulse width	400	--	ns	
DB0 to DB7	t_{DS8}	Data setup time	63	--	ns	
	t_{DH8}	Data hold time	10	--	ns	
	t_{ACC8}	RD access time	--	330	ns	
	t_{OH8}	Output disable time	10	--	ns	

5 Register Table

Reg. No	Reg. Name	R/W	D7	D6	D5	D4	D3	D2	D1	D0	Default Data
00h	WLCR	R/W	PW1	PW0	SR	--	CG	DP	DK	DV	C9h
01h	MISC	R/W	--	CKN	--	PLR	--	--	CKB1	CKB0	F0h
02h	APSR	R/W	--	--	SP1	SP0	OAR	--	SRFS	--	10h
03h	ADSR	R/W	--	--	--	--	DADR	AUCM	AUSG	SGCM	80h
10h	WCCR	R/W	ARI	ALG	WDI	WBC	AWI	CP	CK	CSD	6Fh
11h	CHLD	R/W	CR3	CR2	CR1	CR0	DY3	DY2	DY1	DY0	22h
12h	MAMR	R/W	GIM	RM2	RM1	RM0	OP1	OP2	WM1	WM0	91h
20h	AWRR	R/W	--	--	X5	X4	X3	X2	X1	X0	27h
21h	DWRR	R/W	--	--	A5	A4	A3	A2	A1	A0	27h
30h	AWBR	R/W	Y7	Y6	Y5	Y4	Y3	Y2	Y1	Y0	EFh
31h	DWBR	R/W	B7	B6	B5	B4	B3	B2	B1	B0	EFh
40h	AWLR	R/W	--	--	SS5	SS4	SS3	SS2	SS1	SS0	00h
41h	DWLR	R/W	--	--	C5	C4	C3	C2	C1	C0	00h
50h	AWTR	R/W	SC7	SC6	SC5	SC4	SC3	SC2	SC1	SC0	00h
51h	DWTR	R/W	D7	D6	D5	D4	D3	D2	D1	D0	00h
60h	CPXR	R/W	--	--	RS5	RS4	RS3	RS2	RS1	RS0	00h
61h	BGSG	R/W	--	--	DS5	DS4	DS3	DS2	DS1	DS0	00h
70h	CPYR	R/W	RC7	RC6	RC5	RC4	RC3	RC2	RC1	RC0	00g
71h	BGCM	R/W	CB7	CB6	CB5	CB4	CB3	CB2	CB1	CB0	00h
72h	EDCM	R/W	CD7	CD6	CD5	CD4	CD3	CD2	CD1	CD0	EFh
80h	BTMR	R/W	BT7	BT6	BT5	BT4	BT3	BT2	BT1	BT0	33h
81h	FRCA	R/W	--	--	--	--	--	--	--	--	00h
90h	SCCR	R/W	CK7	CK6	CK5	CK4	CK3	CK2	CK1	CK0	04h
91h	FRCB	R/W	--	--	--	--	--	--	--	--	00h
A0h	INTR	R/W	INK	INT	INX	INY	MSK	MST	MSX	MSY	00h
A1h	KSCR	R/W	KEN	KSZ	KDT1	KDT0	--	KF2	KF1	KF0	00h
A2h	KSDR	RO	KS7	KS6	KS5	KS4	KS3	KS2	KS1	KS0	00h
A3h	KSER	RO	KD7	KD6	KD5	KD4	KD3	KD2	KD1	KD0	00h
B0h	INTX	R/W	--	--	IX5	IX4	IX3	IX2	IX1	IX0	27h
B1h	INTY	R/W	IY7	IY6	IY5	IY4	IY3	IY2	IY1	IY0	EFh
C0h	TPCR	R/W	AZEN	AZOE	--	SCAN	AS3	AS2	AS1	AS0	00h
C1h	TPSR	R/W	ARDY	ADET	1	1	AF1	AF0	--	--	0Fh
C8h	TPXR	RO	TPX9	TPX8	TPX7	TPX6	TPX5	TPX4	TPX3	TPX2	00h
C9h	TPYR	RO	TPY9	TPY8	TPY7	TPY6	TPY5	TPY4	TPY3	TPY2	00h
CAh	TPZR	RO	TPX1	TPX0	--	--	TPY1	TPY0	--	--	00h
D0h	LCCR	R/W	DZEN	--	--	DAC4	DAC3	DAC2	DAC1	DAC0	8Fh
E0h	PNTR	R/W	FD7	FD6	FD5	FD4	FD3	FD2	FD1	FD0	00h
F0h	FNCR	R/W	TNS	BNK	RM1	RM0	FDA	ASC	ABS1	ABS0	92h
F1h	FVHT	R/W	FH1	FH0	FV1	FV0	1	1	1	1	0Fh

Please See Datasheet of LCD Driver for detail.

Appendix

1 Packing Method

Method 1

ESD Bag + Product Box + Plastic Bag + Carton

1. Quantity

QUANTITY	UNIT
1	PCS / ESD Bag
	PCS / Box
	Box / Carton
	PCS / Carton

2. Material

Material	Size (LXWXH) mm
ESD Bag	
Product Box	
Carton	

3. Label

PRODUCT ID:
 PART NO:
 QUANTITY:
 GROSS WEIGHT:
 MEASUREMENTS:

4. Packing Method

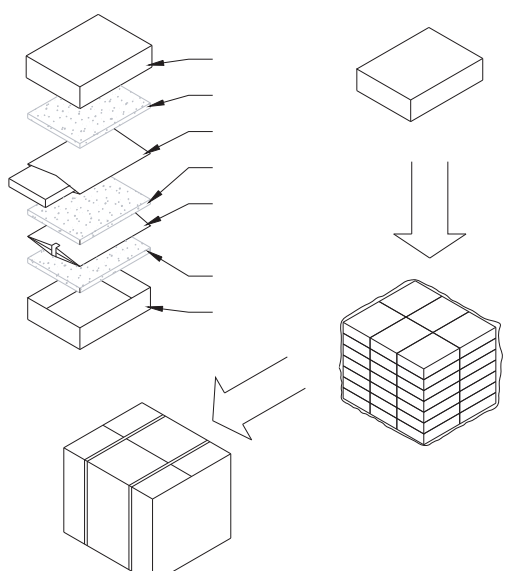

Note: see *table 1. Quantity* for detail.

Method 2

ESD Tray + Plastic Bag + Carton

1. Quantity

QUANTITY	UNIT
	PCS / Tray
	Tray / Carton
	PCS / Carton

2. Material

Material	Size (LXWXH) mm
ESD Tray	
Carton	

3. Label

PRODUCT ID:
 PART NO:
 QUANTITY:
 GROSS WEIGHT:
 MEASUREMENTS:

4. Packing Method

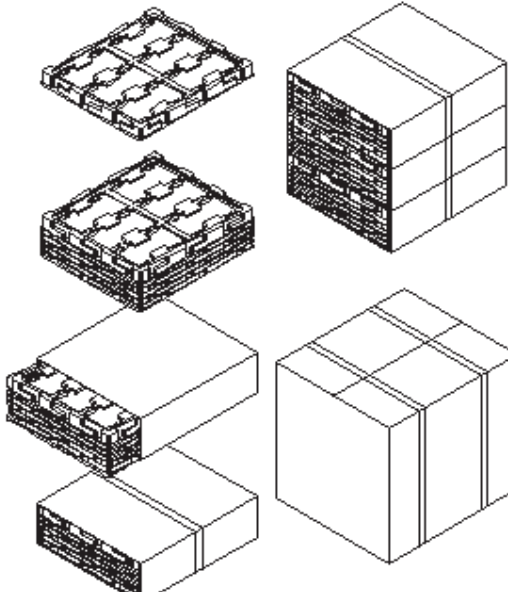

Note: see *table 1. Quantity* for detail.

Note:

Page 10

2 Classification

N/A

3 Handling precaution for LCM

LCM is easy to be damaged. Please note below and be careful for handling!

Correct handling:

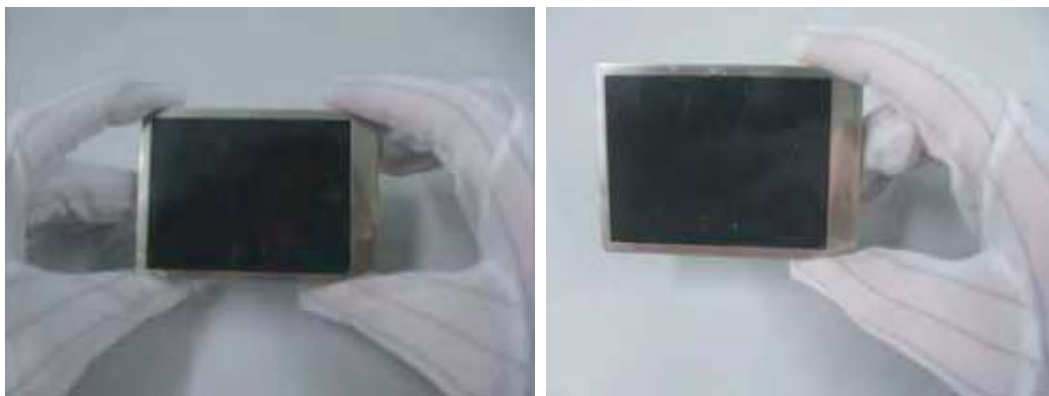

As above picture, please handle with anti-static gloves around LCM edges.

Incorrect handling:

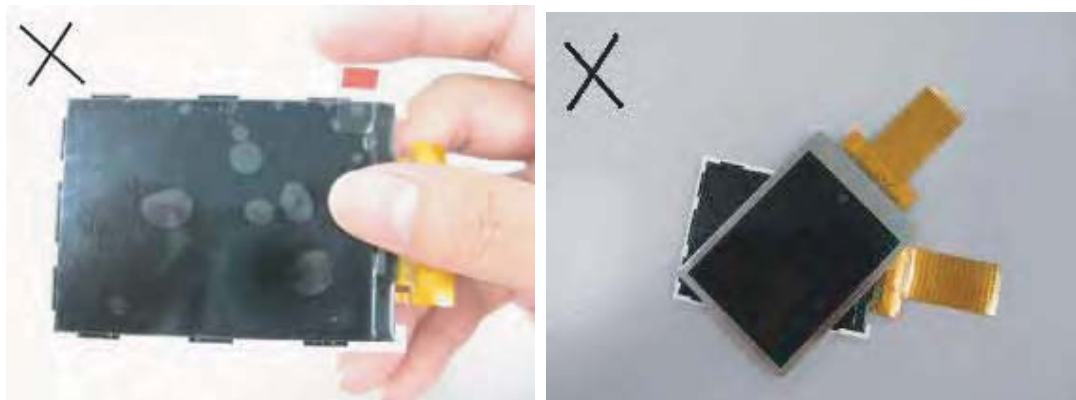

Please don't touch the IC directly.

Please don't stack LCM.



Please don't hold the surface of panel.

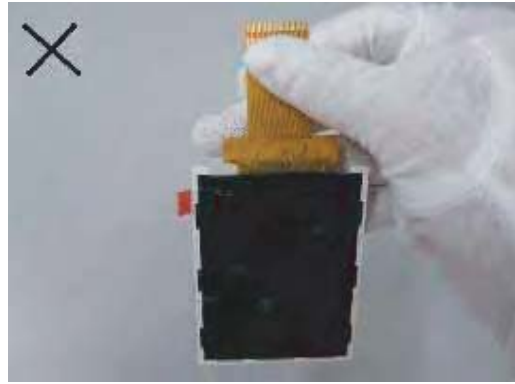

Please don't stretch interface of output ,
such as FPC cable

4 Definitions of Optical Characteristic

4.1 Contrast Ratio Test

Contrast Ratio (CR) is the comparison of the display screen's maximum white luminance (white screen) to its minimum luminance (black screen).

Contrast Ratio is measured perpendicular to the display at the screen's five (5) points

A full white screen and a full black screen are used when measuring luminance for contrast ratio.

$$CR(1,2,3,4,5) = \frac{\text{Surface Luminance of all white screen (1,2,3,4,5)}}{\text{Surface Luminance of all black screen (1,2,3,4,5)}}$$

4.2 Response time

Response time is the measurement of the total time takes to turn a pixel "On" and "Off". pixel is determined to be "On" when its drive voltage reaches 90% of maximum and "Off" when the voltage level drops to 10%. "On" and "Off" are also referred to as "Rise" and "Fall" times.

The response time is defined as the total time takes to turn the screen switching White and Black. Measurements are made at the five (5) points perpendicular to the display surface (Normal Line).

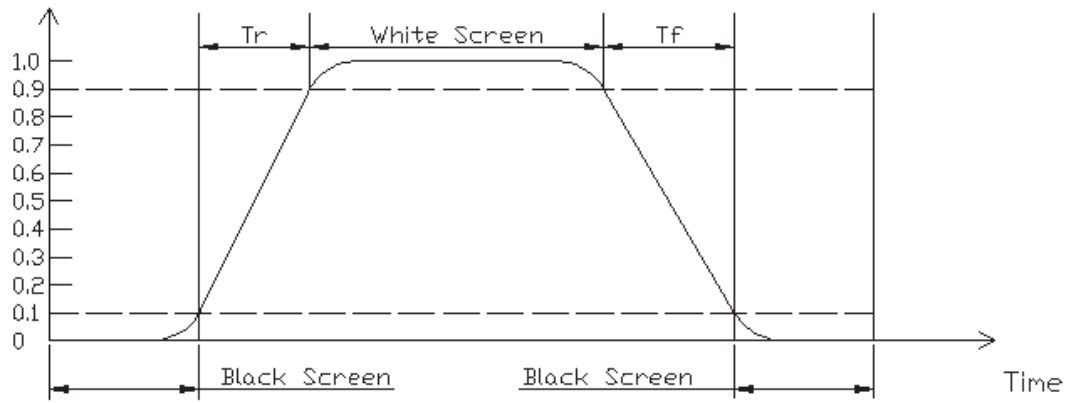

X axis: Time

Y axis: Optical Response by the screen switching "Black" and "White"

$$\text{Response Time} = T_r + T_f$$

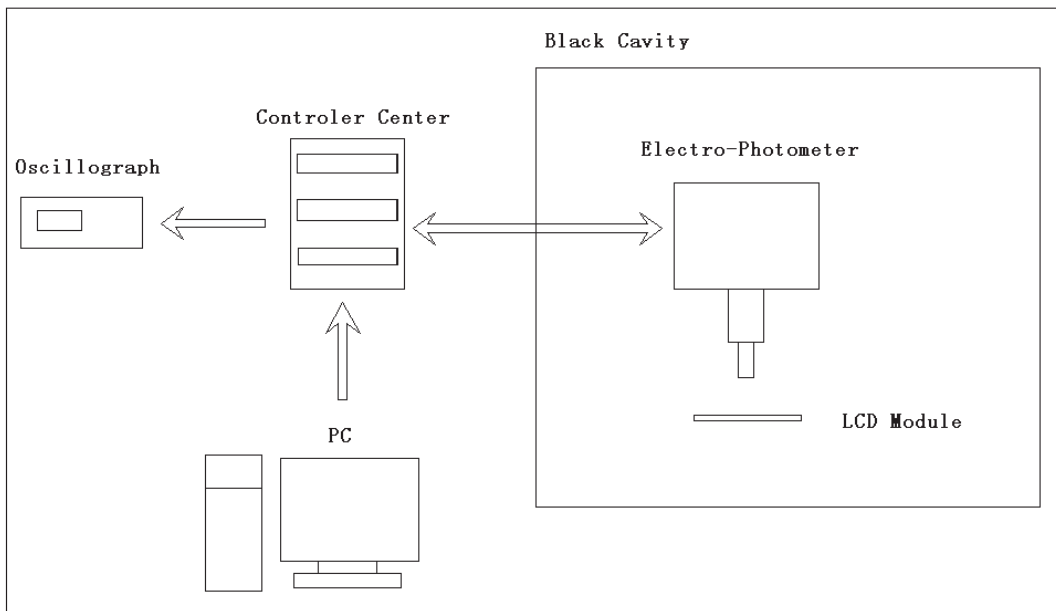

Testing System

4.3 Luminance Measurement

Luminance is a cd/m^2 (nits) measurement of the display's white color (white screen).

All measurements are performed in a dark ambient.

Display luminance is defined as the average value of five (5) white screen measurements. The location of these 5 measurement points is shown in the drawing below.

$$\text{Display Luminance} = \frac{\text{Surface Luminance of all white screen (1 + 2 + 3 + 4 + 5)}}{5}$$

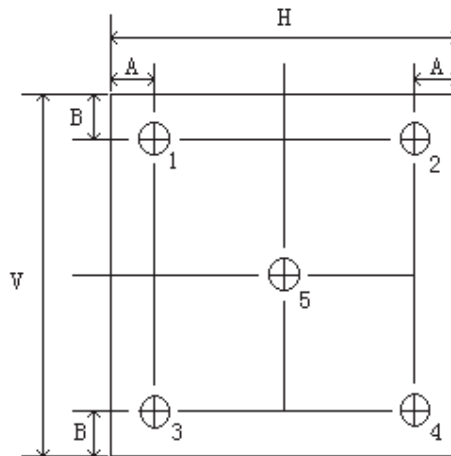

Screen Luminance Measurement Points (5)

A: 5mm

B: 5mm

H V: Active Area

Measuring Equipment: DMS505

Measurement point diameter: 3mm

4.4 White Uniformity Measurement

White luminance uniformity is a cd/m^2 (nits) measurement of the display's white color across the display screen.

All measurements are performed in a dark ambient.

Display luminance uniformity is defined as the percent (%) of luminance value variation over nine (9) white screen measurements. The location of these 9 measurement points is shown in the drawing below.

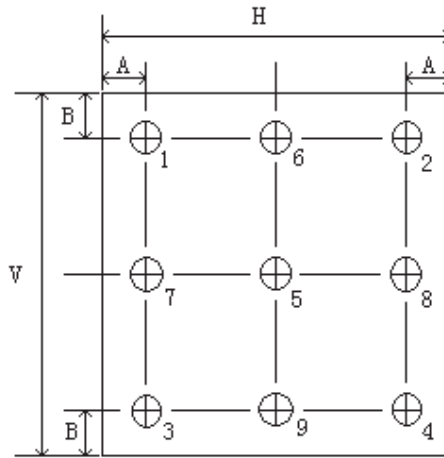

A: 5mm

B: 5mm

H,V: Active Area

Measuring Equipment: DMS505

Measurement point diameter: 3mm

$$\text{Luminance Uniformity} = \frac{\text{Min Luminance(9Pts.1 - 9)}}{\text{Max Luminance(9Pts.1 - 9)}} \times 100\%$$

4.5 Viewing Angle

A) Viewing angle is definition

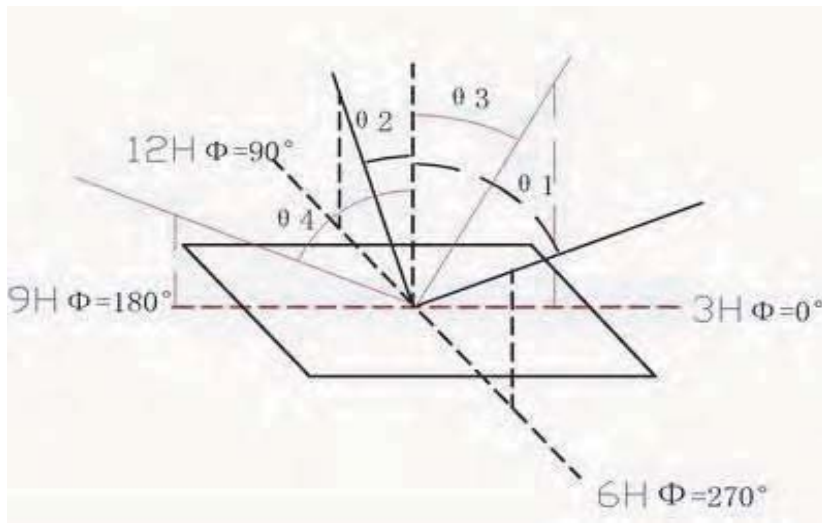

B) System Block Diagram

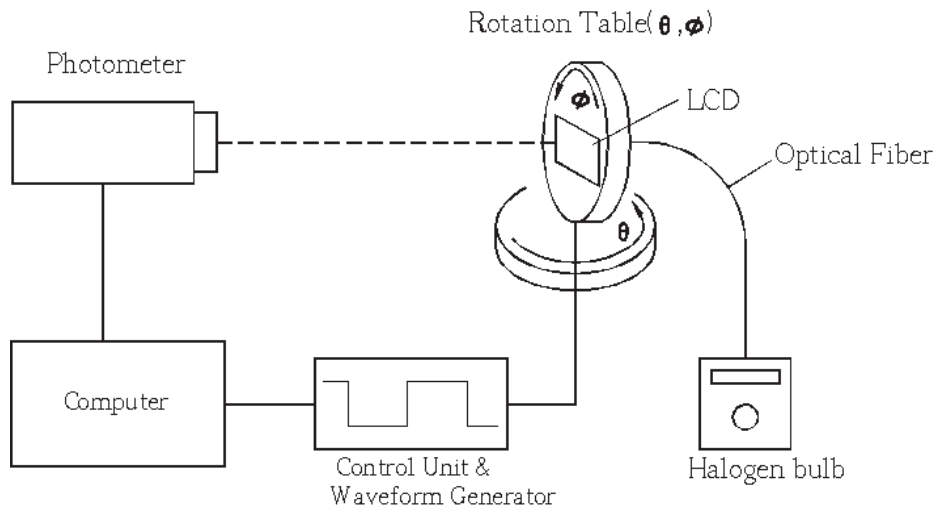

5 QUALITY UNITS

5.1 Visual and Technological Inspection

- Visual inspection must be performed with naked eye on display.
 - Distance between observer and display should be about 30 cm.
 - Perform inspection at OFF state and ON state
 - Ambient lighting should be 1000 lux
 - Transmissive, transreflective and negative type specimens should be inspected in backlight
- (i) Inspecting method:

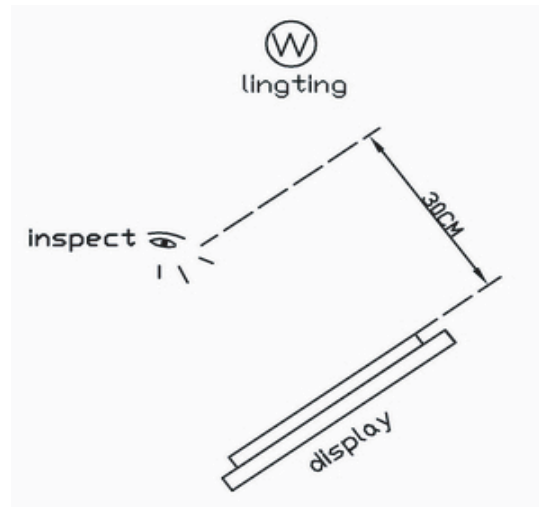

- (ii) Definition of area:

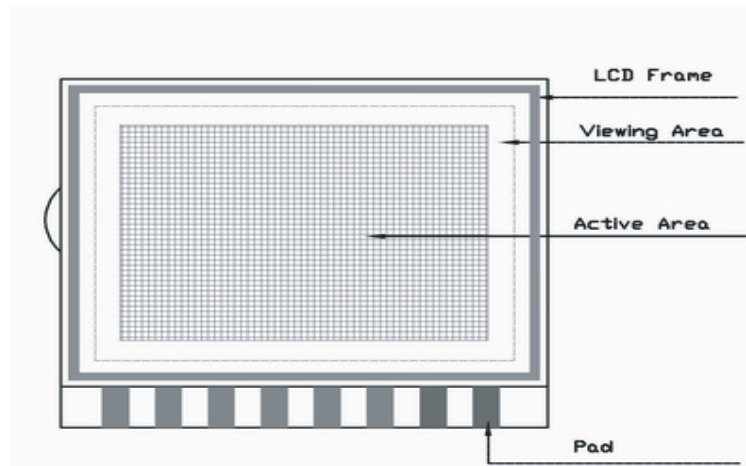

Note: The drawing is a general sketch map only. If want to see the product outline detail, please see the product outline drawing.

5.2 Visual Inspection Standard:

Table1

(Unit: mm)

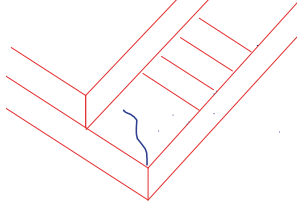
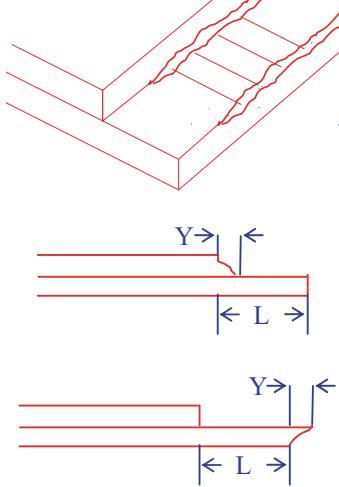
No	Defect Item			Criterion	
	Defect describe	Position	classify	Section	Acceptable Number(N)(*3)
1	Liquid Crystal Leakage				Not acceptable
2	Bubble in Liquid Crystal				Not acceptable
3	Rainbow		Slight? *1??		Acceptable
			Obvious? *2??		Not acceptable
4	ITO Glass Crackle  Pic 1		Slight	Pic 1: Enter into the glass	Not acceptable
			Slight	Pic 2: not Enter into the glass	2
5? *4??	ITO Glass Protrusion:  Pic 2		Slight	1??smaller glass: $Y \leq L/4$, X ignore, $Z \leq t$ 2: larger glass: no influence upon outline dimension?? assemble,display funtion;	2
6? *4??	Chipped Glass:	pad Edge	Slight	$X \leq 4$, $Y \leq 1/3L$, $Z \leq t$? or chip don't touch one third of Pad width.	3

		Non-Pad Edge	Slight	$X \leq 5, Y \leq 1.5, Z \leq t, Y$ can't enter into active area and can't touch the sealant	3
		Corner	Slight	$X \leq 2, Y \leq 2, Z \leq t$	3
7	Black/White Spots (Include LCD and Backlight): Virtual Diameter: $\phi_0 = (a+b)/2$ mm	Circular Type	Slight	$\Phi \leq 0.1$	Acceptable
				$0.1 < \Phi \leq 0.3$	4
		Linear Type	Slight	$B \leq 0.02, A$ neglect	Acceptable
				$B \leq 0.1, A \leq 3$	4
$B > 0.1$	According to the spot's standard				
8	Polarizer Bubble			$\Phi \leq 0.2$	Acceptable
				$0.2 < \Phi \leq 0.4$	4
				$0.4 < \Phi \leq 0.5$	2
Note	1. Slight rainbow: rainbow outside of Viewing Area, or concolorous rainbow inside of Viewing Area but don't go beyond the limited sample which affirmed by purchaser. 2. Obvious rainbow: double color rainbow in Viewing area and go beyond the limited sample which affirmed by purchaser. 3. Acceptable Number(N) is the defects number in the LCD that will be defined according to the defects distributing density. In this table, the acceptable number is $\leq 1/1(\text{cm})^2$. If purchaser has different suggest, please discuss with us.				

5.3 Display Inspection Standard:

Table2

(Unit: mm)

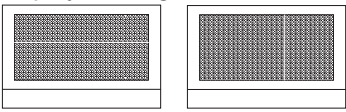
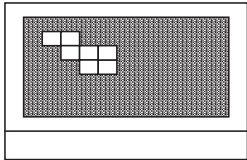
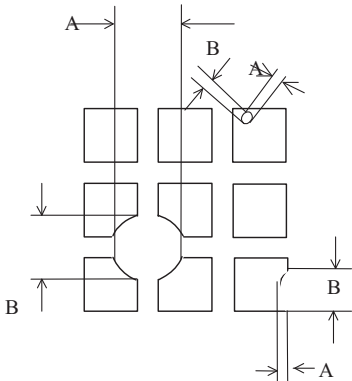
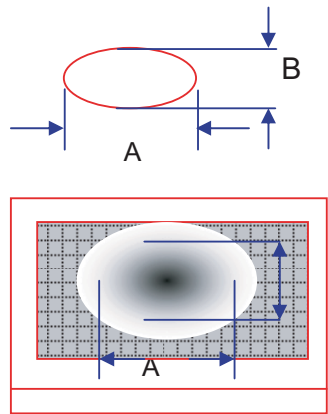
No	Defect Item	Criterion	
		Section	Acceptable Number(N) (*1)
1	Non display		Not acceptable
2	Display missing 		Not acceptable
3	Short Circuit		Not acceptable
4	Abnormal display 		Not acceptable
5	Pin Hole & Gap in displaying segment or Dot Matrix:  Virtual Diameter: $\phi = (a+b)/2$ mm	$\phi \leq 0.1$	Acceptable
		$0.1 < \phi \leq 0.2$	3
		$0.2 < \phi \leq 0.3$	1
		$\phi > 0.3$	Not acceptable
6	Display Black/White Spots  $\phi = (A+B)/2$ mm	The spot's dimension and color don't alter with the voltage alteration	
		$\phi \leq 0.10$	acceptable
		$0.10 < \phi \leq 0.2$	3
		$0.2 < \phi \leq 0.3$	1
		$\phi > 0.3$	Not acceptable
		The spot's dimension and color alter with the voltage alteration	
		$\phi \leq 0.3$	acceptable
		$0.3 < \phi \leq 0.5$	3
$0.5 < \phi \leq 0.8$	1		
$\phi > 0.8$	Not acceptable		
7	Display Black/White lines	The Line's dimension and color don't alter with the voltage alteration	
		$B \leq 0.05$ $A \leq 2$	acceptable
		$0.05 < B \leq 0.1$ $A \leq 2$	3
	$B > 0.1$	According to the spot's standard	

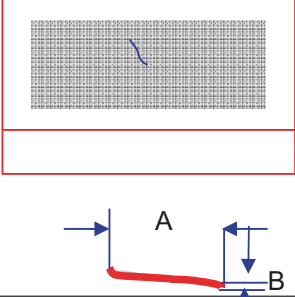
		The Line's dimension and color alter with the voltage alteration	
		$B \leq 0.07$ $A \leq 5$	acceptable
		$0.07 < B \leq 0.15$ $A \leq 5$	3
		$0.15 < B \leq 0.3$ $A \leq 5$	1
		$B > 0.3$	According to the spot's standard
8	The current overflow		Not acceptable
Note	1. when the width value of Segment or Dot Matrix is less than 3.0 mm, no default is acceptable 2. No more than 5 defaults are acceptable in 1cm^2 area.		

6 Reliability-TEST

6.1 Standard Specifications for Reliability

6.1-1 Test method

There should be no existing conspicuous failure of functions and appearance in LCD after the following tests.

NO	Item	Description
1	Low Temperature Operating	The sample should be allowed to stand at $(-20 \pm 2)^\circ\text{C}$ for 96 Hours under driving condition.
2	High Temperature Operating	The sample should be allowed to stand at $(70 \pm 2)^\circ\text{C}$ for 96 Hours under driving condition.
3	Low Temperature Storage	The sample should be allowed to stand at $(-40 \pm 3)^\circ\text{C}$ for 96 Hours under no-load condition, and then returning it to normal temperature condition, and allowing it stand for 24 hours
4	High Temperature Storage	The sample should be allowed to stand at $(80 \pm 2)^\circ\text{C}$ for 96Hours under no-load condition, and then returning it to normal temperature condition, and allowing it stand for 24 hours
5	Moisture resistance	The sample should be allowed to stand at $(40 \pm 2)^\circ\text{C}$, $(95 \pm 2)\% \text{RH}$ for 96Hours under no-load condition excluding the polarizer, then taking it out and drying it at normal temperature, and allowing it stand for 24 hours
6	Thermal Shock Resistance	The sample should be allowed to stand the following 5 cycles of operation: T_{STL}^* for 30 minutes \rightarrow normal temperature for 5 minutes $\rightarrow T_{\text{STH}}^*$ for 30 minutes \rightarrow normal temperature for 5 minutes, as one cycle, then taking it out and drying it at normal temperature, and allowing it stand for 24 hours

Note:

T_{STL} : Lowest Storage Temperature.

T_{STH} : Highest Storage Temperature.

6.1-2 Testing Conditions and Inspection Criteria:

For the final test, the testing sample must be stored at room temperature for 24 hours, after the

tests listed above; Standard specifications for Reliability have been executed in order to ensure stability.

NO	Item	Inspection Criteria
1	Current Consumption	The current consumption should be under double of initial test.
2	Contrast	The contrast must be larger than half of initial test.
3	Appearance	Appearance defects should not happen.

6.2 Life Time

Functions, performance, appearance, etc. shall be free from remarkable deterioration within 50,000 hours under ordinary operating and storage conditions room temperature ($25\pm 10^{\circ}\text{C}$), normal humidity ($45\pm 20\%\text{RH}$), and in area not exposed to direct sunlight.