

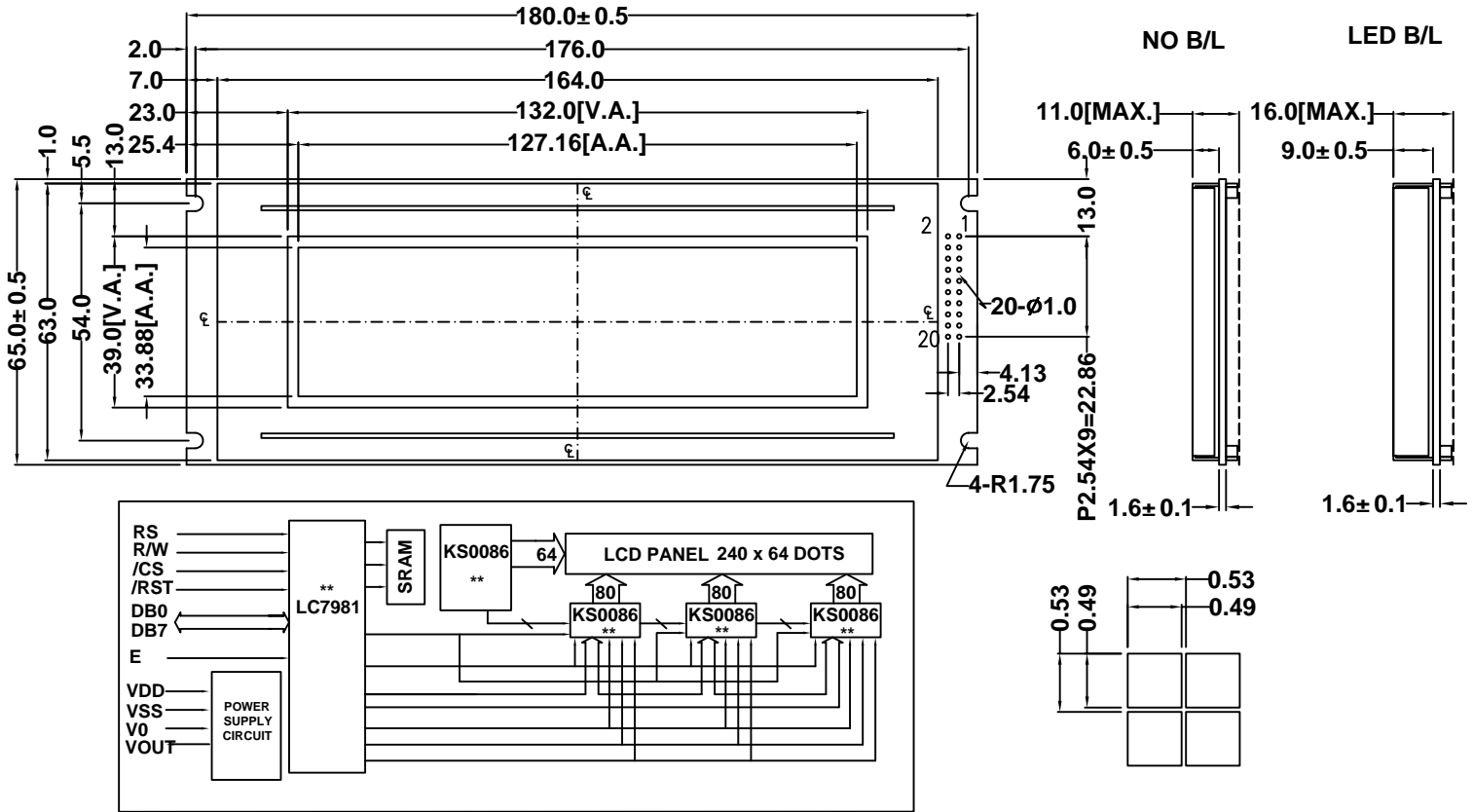

AMG24064B

CONTOUR DRAWING & BLOCK DIAGRAM



* OR EQUIVALENT

MECHANICAL SPECIFICATION		
ITEM	SPECIFICATION	UNIT
Module Size	180.0X65.0X11.0/14.0	mm
Viewing Area	132.2X39.0	mm
Number of dots	240X64	dots
Dot Pitch	0.53X0.53	mm
Dot Size	0.49X0.49	mm

ABSOLUTE MAXIMUM RATINGS				
PARAMETER	SYMBOL	MIN.	MAX.	UNIT
Supply Voltage	Vdd	-0.3	7.0	V
LCD Supply Voltage	Vlcd(Vdd-V0)	0	16	V
Input Voltage	Vin	-0.3	Vdd+0.3	V
Operating Temperature*	Top	0/-20	50/70	° C
Storage Temperature*	Tstr	-10/-30	60/80	° C

PIN CONNECTIONS		
PIN	SYMBOL	DESCRIPTION
1	VSS	Ground
2	VDD	Supply voltage for LCD(+)
3	V0	Supply voltage for LCD(-)
4	RS	Command/Data Select
5	RW	Data Write/Read
6	E	Chip Enable
7-14	DB0-DB7	Data Bus
15	/CS	Chip Select
16	/RST	Reset
17	VOUT	Negative Voltage Output
18	NC	NC
19	A	Anode for backlight
20	K	Cathode for backlight

ELECTRICAL CHARACTERISTICS(Ta=25° C)						
ITEM	SYMBOL	CONDITION	MIN.	TYP.	MAX.	UNIT
Supply Voltage(logic)	Vdd	-	4.5	5.0	5.5	V
Supply Current(logic)	Idd	Vdd=5.0	2.0	-	-	mA
Driving Voltage(LCD)	Vlcd	-	-	13.0	-	V
Driving Current(LCD)	Ilcd	-	-	0.3	0.6	mA

BACKLIGHT CHARACTERISTICS (Ta=25° C)						
PARAMETER	SYMBOL	CONDITION	MIN.	TYP.	MAX.	UNIT
Supply Voltage	Vf	If=1000mA	3.8	4.2	4.3	V
LED Forward Current	If	-	-	1000	-	mA
LED Dissipation	Pd	-	-	4200	-	mW

*T1/T2: T1for standard temperature LCM, T2 for wide temperature LCM