

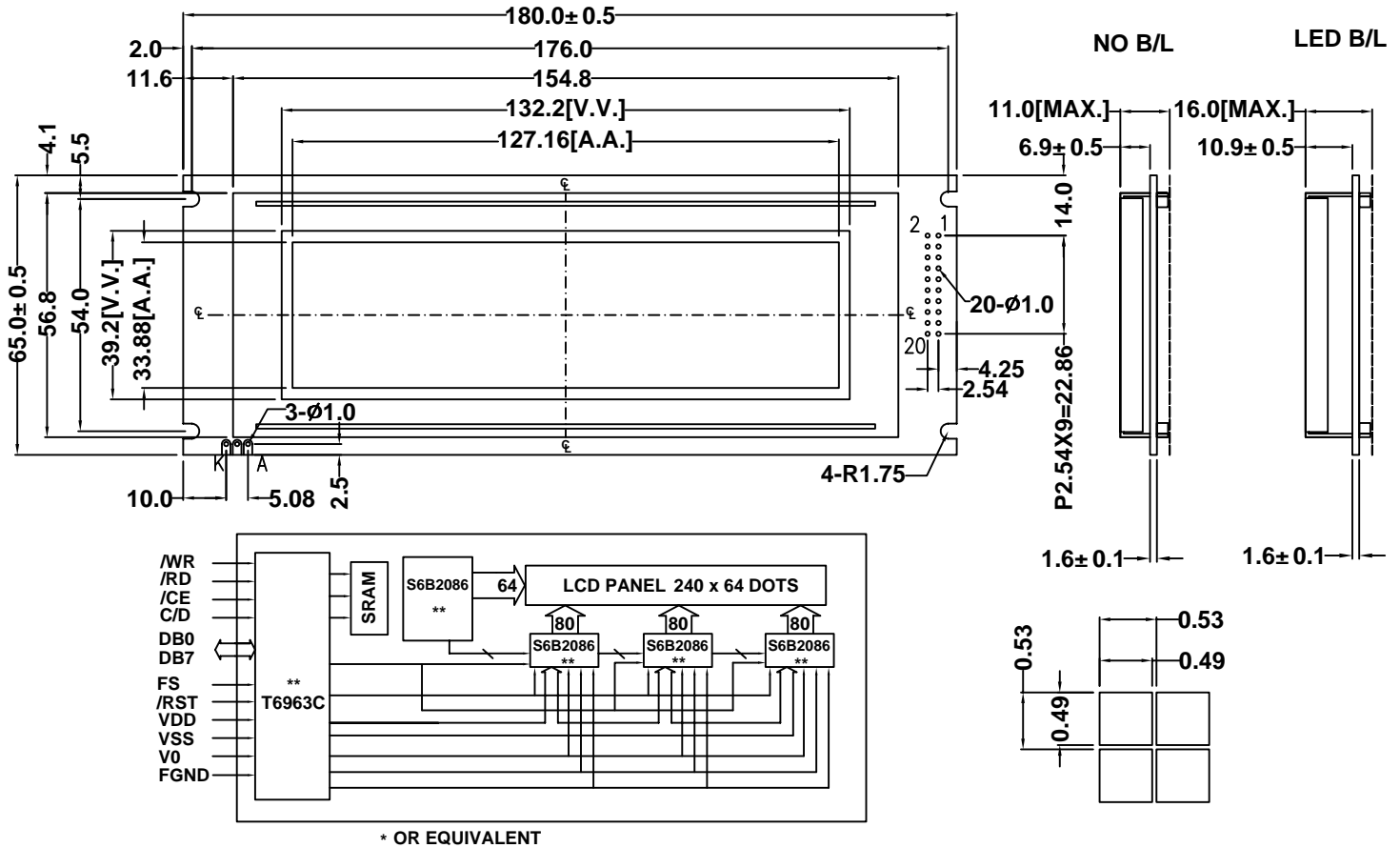

# AMG24064A

## CONTOUR DRAWING & BLOCK DIAGRAM



\* OR EQUIVALENT

MECHANICAL SPECIFICATION		
ITEM	SPECIFICATION	UNIT
Module Size	180.0X65.0X11.0/14.0	mm
Viewing Area	132.2X39.2	mm
Number of dots	240X64	dots
Dot Pitch	0.53X0.53	mm
Dot Size	0.49X0.49	mm

ABSOLUTE MAXIMUM RATINGS				
PARAMETER	SYMBOL	MIN.	MAX.	UNIT
Supply Voltage	Vdd	-0.3	7.0	V
LCD Supply Voltage	Vlcd(Vdd-V0)	0	16	V
Input Voltage	Vin	-0.3	Vdd+0.3	V
Operating Temperature*	Top	0/-20	50/70	° C
Storage Temperature*	Tstr	-10/-30	60/80	° C

PIN CONNECTIONS		
PIN	SYMBOL	DESCRIPTION
1	FGND	Frame GND
2	VSS	Ground
3	VDD	Supply voltage for LCD(+)
4	V0	Supply voltage for LCD(-)
5	/MR	Write Data into T6963C
6	/RD	Read Data from T6963C
7	/CS	Chip enable for T6963C
8	C/D	Register Select
9	NC	NC
10	/RST	Reset
11-18	DB0-DB7	Data Bus
19	FS	Pins for selection of font
20	NC	NC

ELECTRICAL CHARACTERISTICS(Ta=25° C)						
ITEM	SYMBOL	CONDITION	MIN.	TYP.	MAX.	UNIT
Supply Voltage(logic)	Vdd	-	4.5	5.0	5.5	V
Supply Current(logic)	Idd	Vdd=5.0	9.0	9.9	12.0	mA
Driving Voltage(LCD)	Vlcd	-	12.0	12.5	13.2	V
Driving Current(LCD)	Ilcd	-	-	1.6	1.9	mA

BACKLIGHT CHARACTERISTICS (Ta=25° C)						
PARAMETER	SYMBOL	CONDITION	MIN.	TYP.	MAX.	UNIT
Supply Voltage	Vf	If=630mA	3.8	4.2	4.3	V
LED Forward Current	If	-	-	630	-	mA
LED Dissipation	Pd	-	-	2646	-	mW

\*T1/T2: T1for standard temperature LCM, T2 for wide temperature LCM



# AMG24064A

## CONTOUR DRAWING & BLOCK DIAGRAM

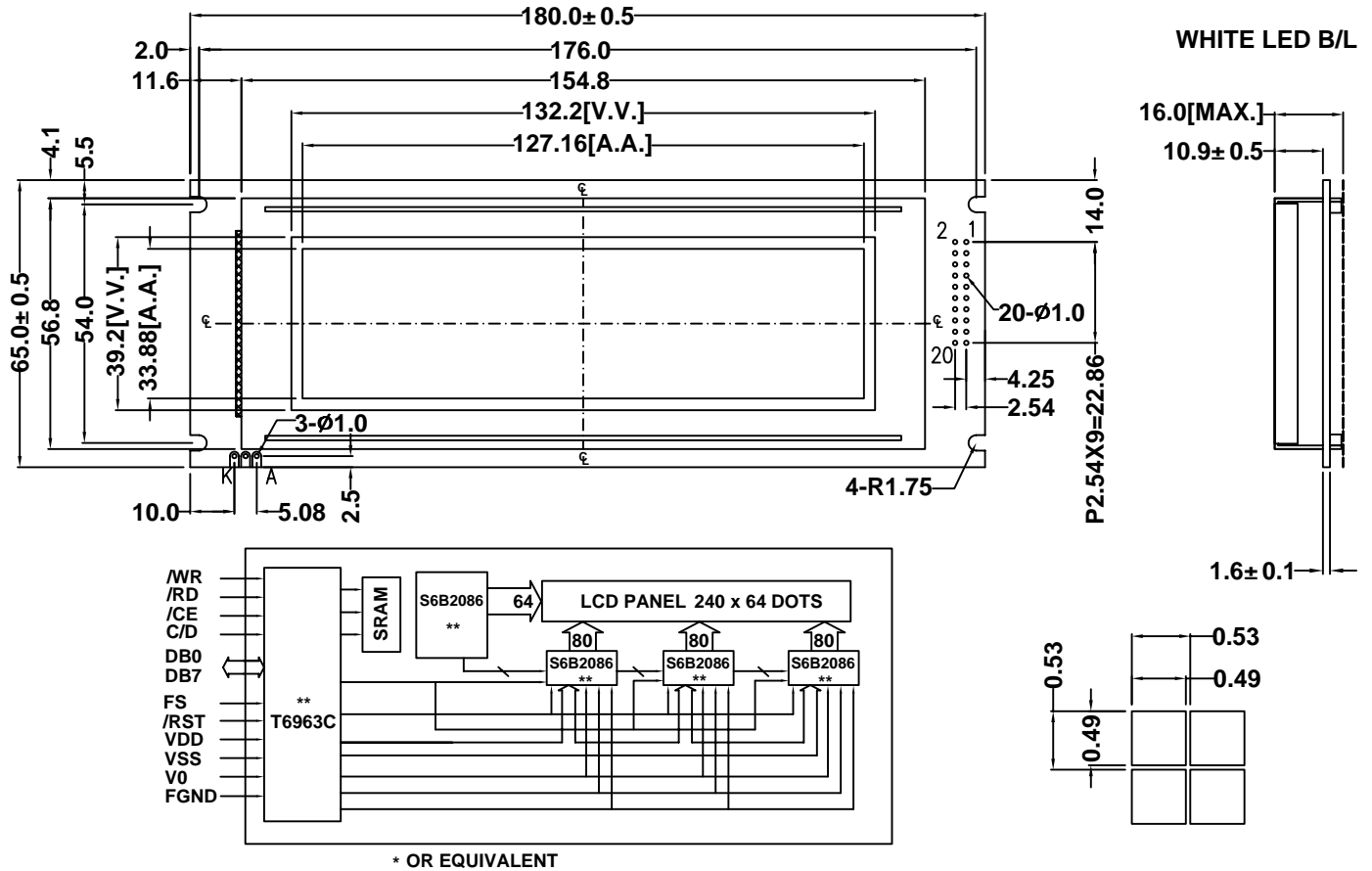

MECHANICAL SPECIFICATION		
ITEM	SPECIFICATION	UNIT
Module Size	180.0X65.0X11.0/14.0	mm
Viewing Area	132.2X39.2	mm
Number of dots	240X64	dots
Dot Pitch	0.53X0.53	mm
Dot Size	0.49X0.49	mm

ABSOLUTE MAXIMUM RATINGS				
PARAMETER	SYMBOL	MIN.	MAX.	UNIT
Supply Voltage	Vdd	-0.3	7.0	V
LCD Supply Voltage	Vlcd(Vdd-V0)	0	16	V
Input Voltage	Vin	-0.3	Vdd+0.3	V
Operating Temperature*	Top	0/-20	50/70	°C
Storage Temperature*	Tstr	-10/-30	60/80	°C

PIN CONNECTIONS		
PIN	SYMBOL	DESCRIPTION
1	FGND	Frame GND
2	VSS	Ground
3	VDD	Supply voltage for LCD(+)
4	V0	Supply voltage for LCD(-)
5	/MR	Write Data into T6963C
6	/RD	Read Data from T6963C
7	/CS	Chip enable for T6963C
8	C/D	Register Select
9	NC	NC
10	/RST	Reset
11-18	DB0-DB7	Data Bus
19	FS	Pins for selection of font
20	NC	NC

ELECTRICAL CHARACTERISTICS(Ta=25° C)						
ITEM	SYMBOL	CONDITION	MIN.	TYP.	MAX.	UNIT
Supply Voltage(logic)	Vdd	-	4.5	5.0	5.5	V
Supply Current(logic)	Idd	Vdd=5.0	9.0	9.9	12.0	mA
Driving Voltage(LCD)	Vlcd	-	12.0	12.5	13.2	V
Driving Current(LCD)	Ilcd	-	-	1.6	1.9	mA

BACKLIGHT CHARACTERISTICS (Ta=25° C)						
PARAMETER	SYMBOL	CONDITION	MIN.	TYP.	MAX.	UNIT
Supply Voltage	Vf	If=60mA	2.9	3.1	3.3	V
LED Forward Current	If	-	-	60	-	mA
LED Dissipation	Pd	-	-	180	-	mW

\*T1/T2: T1for standard temperature LCM, T2 for wide temperature LCM