

# AMG19264A

Unmarked tolerance ±0.3

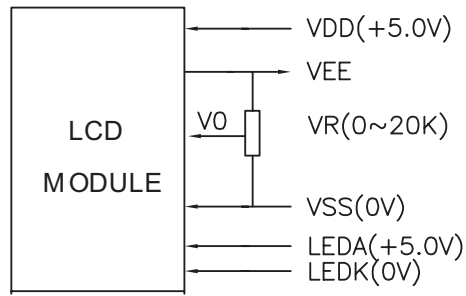
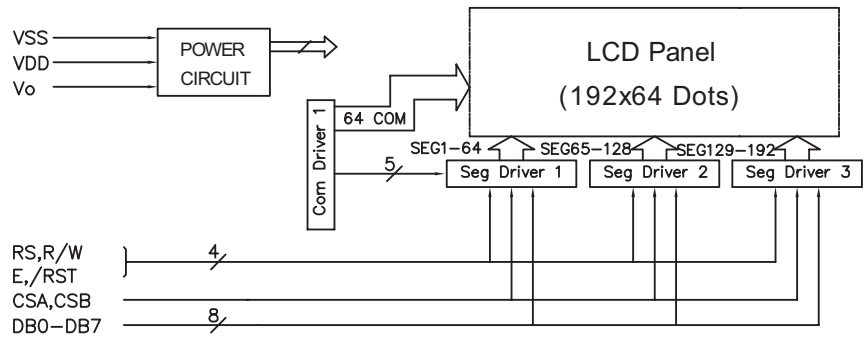
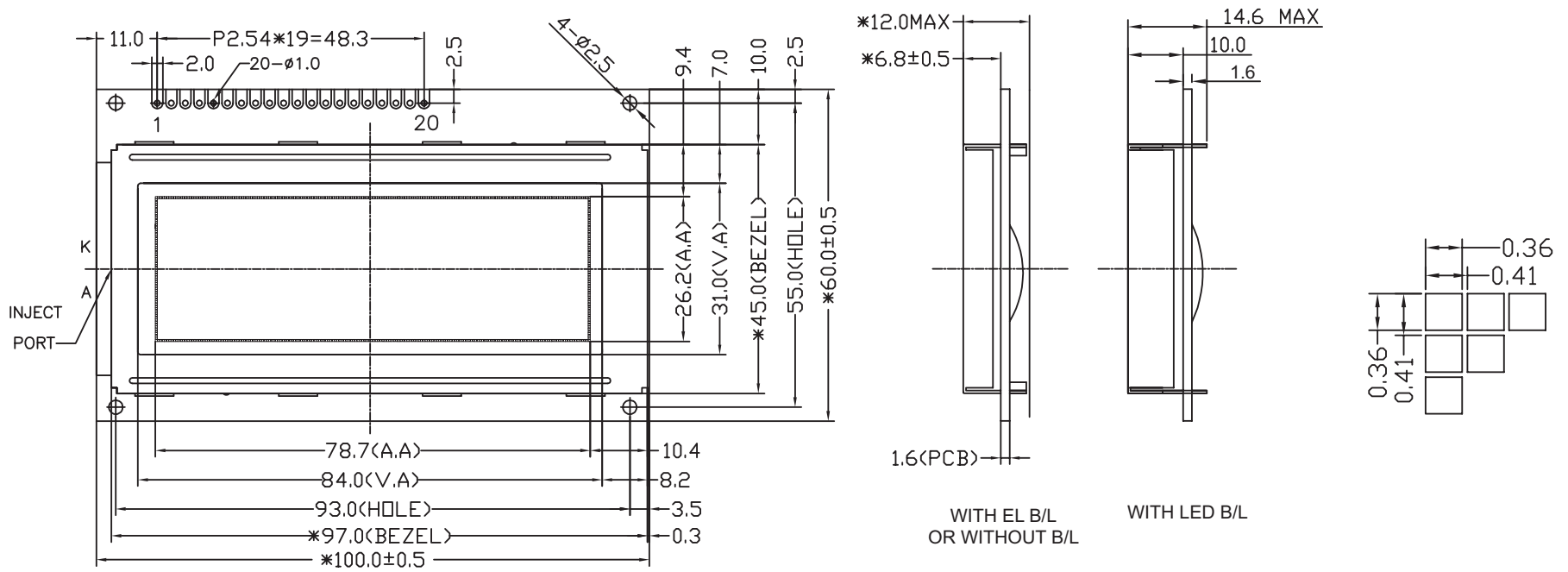

Pin No	Symbol	Pin No	Symbol
1	DB7	11	RS
2	DB6	12	V0
3	DB5	13	VDD
4	DB4	14	VSS
5	DB3	15	CSB
6	DB2	16	CSA
7	DB1	17	VEE
8	DB0	18	/RST
9	E	19	LEDA
10	R/W	20	LEDK