

# AMG12864F

Unmarked tolerance ± 0.3

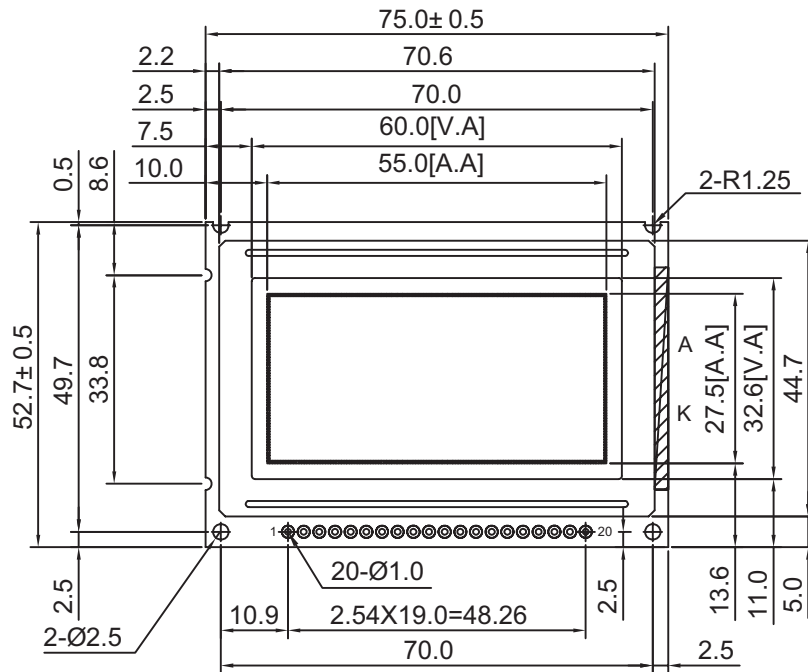

WITH LED B.L.

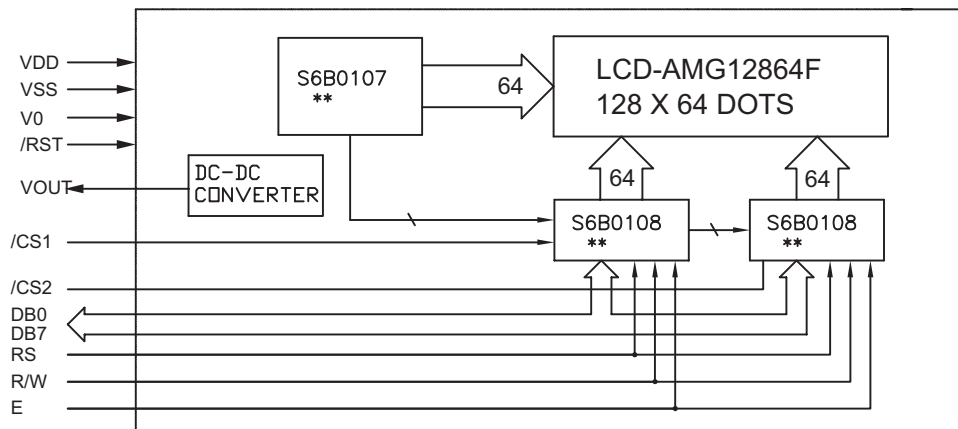
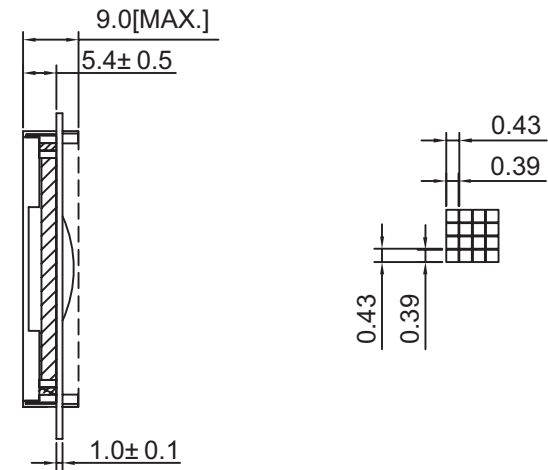

\*\* OR EQUIVALENT

Pin No	Symbol	Pin No	Symbol
1	VDD	11	DB7
2	VSS	12	/CS1
3	V0	13	/CS2
4	DB0	14	/RST
5	DB1	15	R/W
6	DB2	16	RS
7	DB3	17	E
8	DB4	18	VOUT
9	DB5	19	A
10	DB6	20	K