

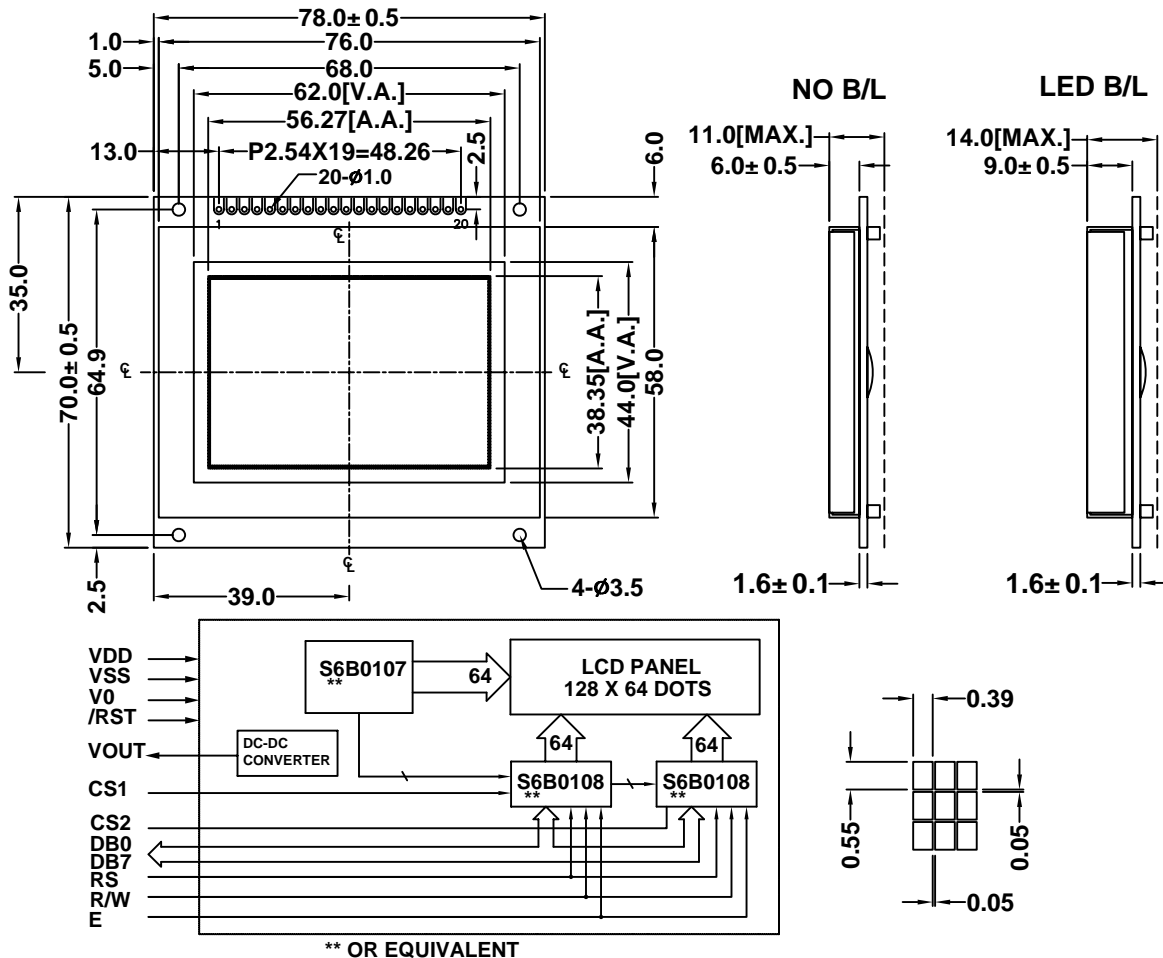

AMG12864B

CONTOUR DRAWING & BLOCK DIAGRAM



** OR EQUIVALENT

MECHANICAL SPECIFICATION		
ITEM	SPECIFICATION	UNIT
Module Size	78.0X70.0X11.0/14.0	mm
Viewing Area	62.0X44.0	mm
Number of dots	128X64	dots
Dot Pitch	0.44X0.60	mm
Dot Size	0.39X0.55	mm

ABSOLUTE MAXIMUM RATINGS				
PARAMETER	SYMBOL	MIN.	MAX.	UNIT
Supply Voltage	Vdd	-0.3	7.0	V
LCD Supply Voltage	Vlcd(Vdd-V0)	0	16	V
Input Voltage	Vin	-0.3	Vdd+0.3	V
Operating Temperature*	Top	0/-20	50/70	° C
Storage Temperature*	Tstr	-10/-30	60/80	° C

PIN CONNECTIONS		
PIN	SYMBOL	DESCRIPTION
1	VSS	Power Supply :0V
2	VDD	Power Supply :+5V
3	V0	Supply voltage for LCD
4	RS	Register Select
5	R/W	Read/Write
6	E	Enable
7-14	DB0-DB7	Data Bus
15	CS1	Chip1 Select Signal
16	CS2	Chip2 Select Signal
17	/RST	Reset Signal
18	VOUT	Negative Voltage
19	A	Anode for backlight
20	K	Cathode for backlight

ELECTRICAL CHARACTERISTICS(Ta=25° C)						
ITEM	SYMBOL	CONDITION	MIN.	TYP.	MAX.	UNIT
Supply Voltage(logic)	Vdd	-	4.5	5.0	5.5	V
Supply Current(logic)	Idd	Vdd=5.0	-	5.1	9.8	mA
Driving Voltage(LCD)	Vlcd	-	-	9.0	-	V
Driving Current(LCD)	Ilcd	-	-	-	-	mA

BACKLIGHT CHARACTERISTICS (Ta=25° C)						
PARAMETER	SYMBOL	CONDITION	MIN.	TYP.	MAX.	UNIT
Supply Voltage	Vf	If=440mA	3.8	4.1	4.3	V
LED Forward Current	If	-	-	440	-	mA
LED Dissipation	Pd	-	-	1800	-	mW

*T1/T2: T1for standard temperature LCM, T2 for wide temperature LCM