

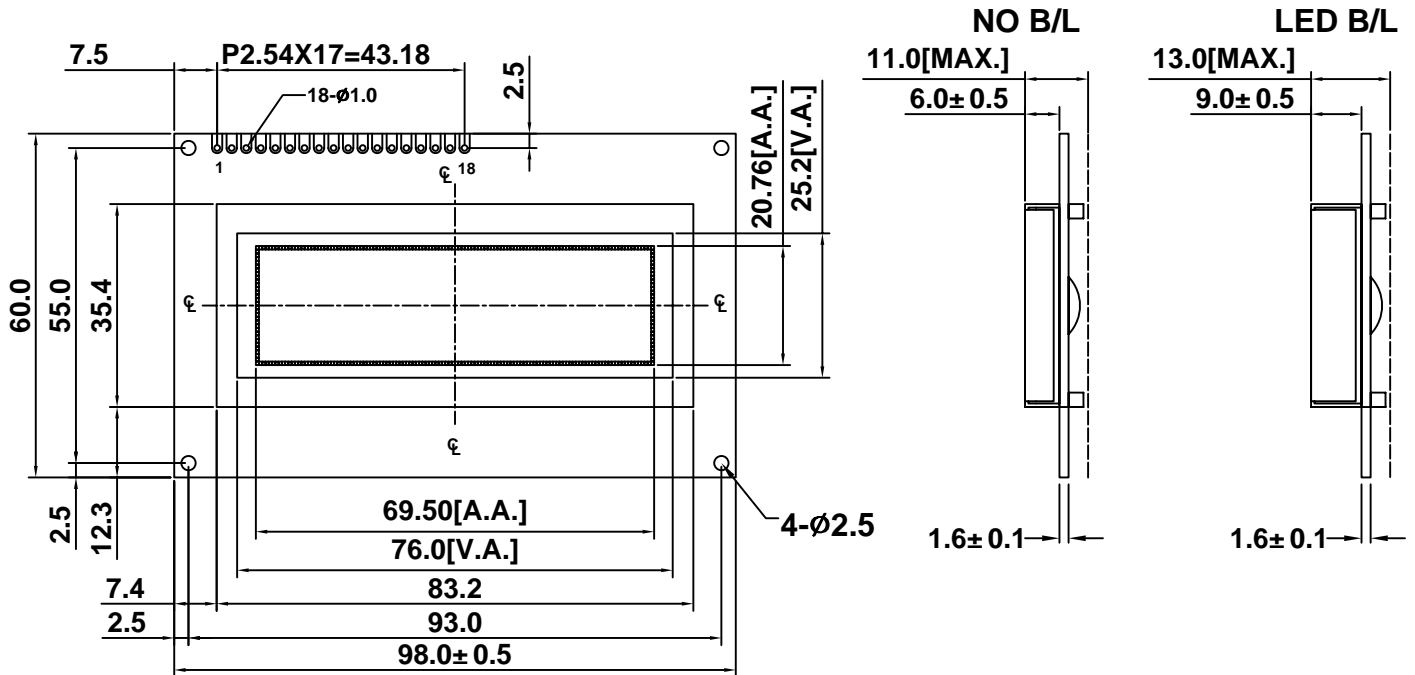

AMG12232C

CONTOUR DRAWING & BLOCK DIAGRAM



** OR EQUIVALENT

MECHANICAL SPECIFICATION		
ITEM	SPECIFICATION	UNIT
Module Size	98.0X60.0X13.0	mm
Viewing Area	76.0X25.2	mm
Display Font	122X32	dots
Dot Pitch	0.57X0.65	mm
Dot Size	0.53X0.61	mm

ABSOLUTE MAXIMUM RATINGS				
PARAMETER	SYMBOL	MIN.	MAX.	UNIT
Supply Voltage	Vdd	-0.3	7.0	V
LCD Supply Voltage	Vlcd(Vdd-V0)	0	12	V
Input Voltage	Vin	-0.3	Vdd+0.3	V
Operating Temperature*	Top	0/-20	50/70	° C
Storage Temperature*	Tstr	-10/-30	60/80	° C

PIN CONNECTIONS		
PIN	SYMBOL	DESCRIPTION
1	VSS	Ground
2	VDD	Supply voltage for LCD(+)
3	V0	Supply voltage for LCD(-)
4	A0	Register Slecter
5	E1	Enable For Chip1
6	E2	Enable For Chip2
7-14	DB0-DB7	DATA Bus
15	A	Anode for backlight
16	K	Cathode for backlight
17	R/W	Read/Write
18	RST	Reset signal

ELECTRICAL CHARACTERISTICS(Ta=25° C)						
ITEM	SYMBOL	CONDITION	MIN.	TYP.	MAX.	UNIT
Supply Voltage(logic)	Vdd	-	4.5	5.0	5.5	V
Supply Current(logic)	Idd	Vdd=5.0	-	12.0	20.0	mA
Driving Voltage(LCD)	Vlcd	-	-	5.5	-	V
Driving Current(LCD)	Ilcd	-	-	-	-	mA

BACKLIGHT CHARACTERISTICS (Ta=25° C)						
PARAMETER	SYMBOL	CONDITION	MIN.	TYP.	MAX.	UNIT
Supply Voltage	Vf	If=240mA	3.8	4.1	4.3	V
LED Forward Current	If	-	-	240	-	mA
LED Dissipation	Pd	-	-	1008	-	mW

*T1/T2: T1for standard temperature LCM, T2 for wide temperature LCM