

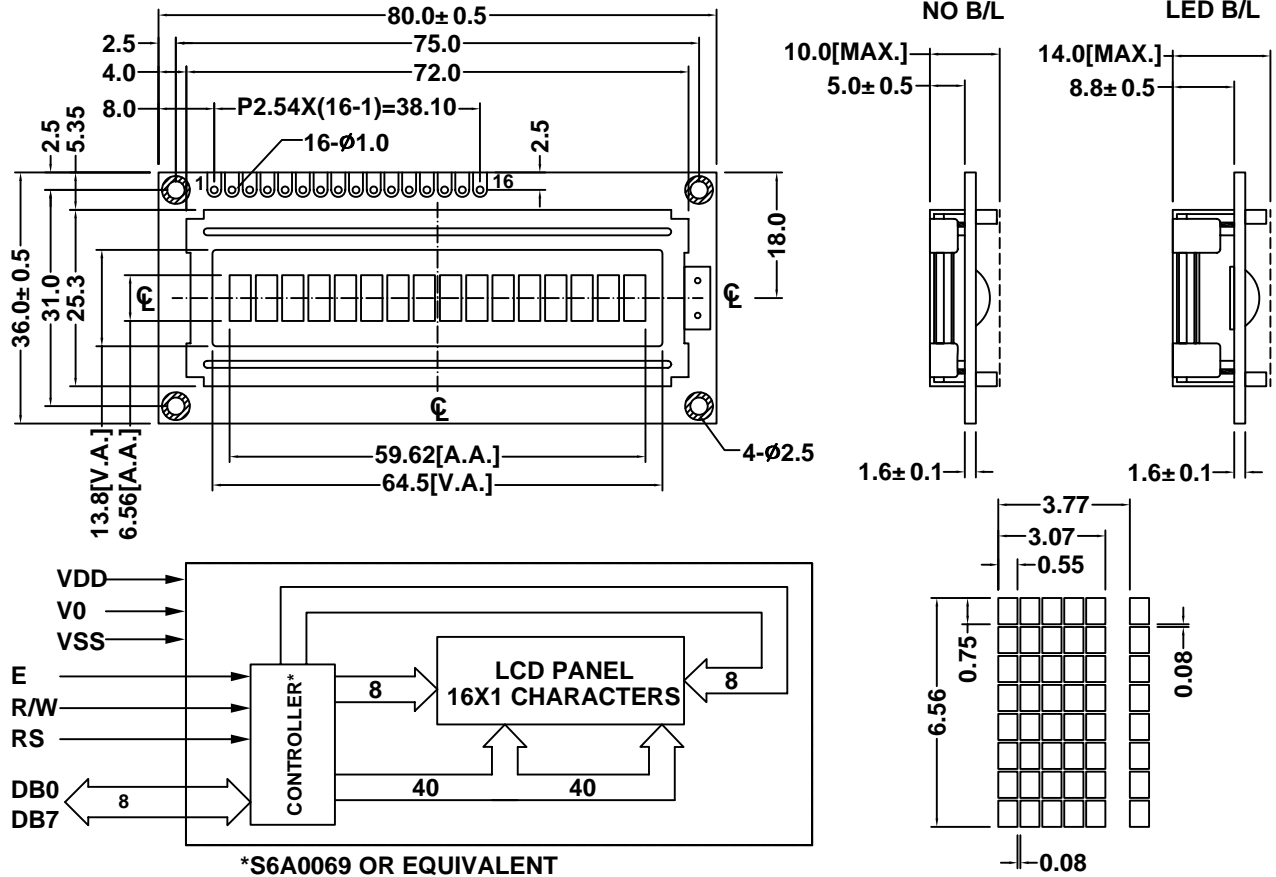

# AMC1601A

## CONTOUR DRAWING & BLOCK DIAGRAM



\*S6A0069 OR EQUIVALENT

MECHANICAL SPECIFICATION		
ITEM	SPECIFICATION	UNIT
Module Size	80.0X36.0X10.0/14.0	mm
Viewing Area	64.5X13.8	mm
Character Font	5 x 7 + cursor	dots
Character Size	3.07X6.56	mm
Character Pitch	3.77	mm
Dot Size	0.55X0.75	mm

ABSOLUTE MAXIMUM RATINGS				
PARAMETER	SYMBOL	MIN.	MAX.	UNIT
Supply Voltage	Vdd	-0.3	7.0	V
LCD Supply Voltage	Vlcd(Vdd-V0)	-13.5	0.3	V
Input Voltage	Vin	-0.3	Vdd+0.3	V
Operating Temperature*	Top	0/-20	50/70	° C
Storage Temperature*	Tstr	-10/-30	60/80	° C

\*T1/T2: T1 for standard temperature LCM, T2 for wide temperature LCM

PIN CONNECTIONS		
PIN	SYMBOL	DESCRIPTION
1	VSS	Power Supply : 0V
2	VDD	Power Supply : +5V
3	V0	Power Supply for LCD
4	RS	Register Select
5	R/W	Read/Write
6	E	Enable
7 to 14	DB0-DB7	Data Bus
15	A	Anode for backlight
16	K	Cathode for backlight

ELECTRICAL CHARACTERISTICS(Ta=25° C)						
ITEM	SYMBOL	CONDITION	MIN.	TYP.	MAX.	UNIT
Supply Voltage(logic)	Vdd	-	4.5	5.0	5.5	V
Supply Current(logic)	Idd	Vdd=5.0	0.5	0.7	1.5	mA
Driving Voltage(LCD)	Vlcd	-	4.5	5.0	5.5	V
Driving Current(LCD)	Ilcd	-	-	0.2	0.4	mA

BACKLIGHT CHARACTERISTICS (Ta=25° C)						
PARAMETER	SYMBOL	CONDITION	MIN.	TYP.	MAX.	UNIT
Supply Voltage	Vf	If=100mA	3.8	4.1	4.3	V
LED Forward Current	If		-	100	-	mA
LED Dissipation	Pd		-	410	-	mW