

4

3

2

1

E

D

C

B

E

D

C

B

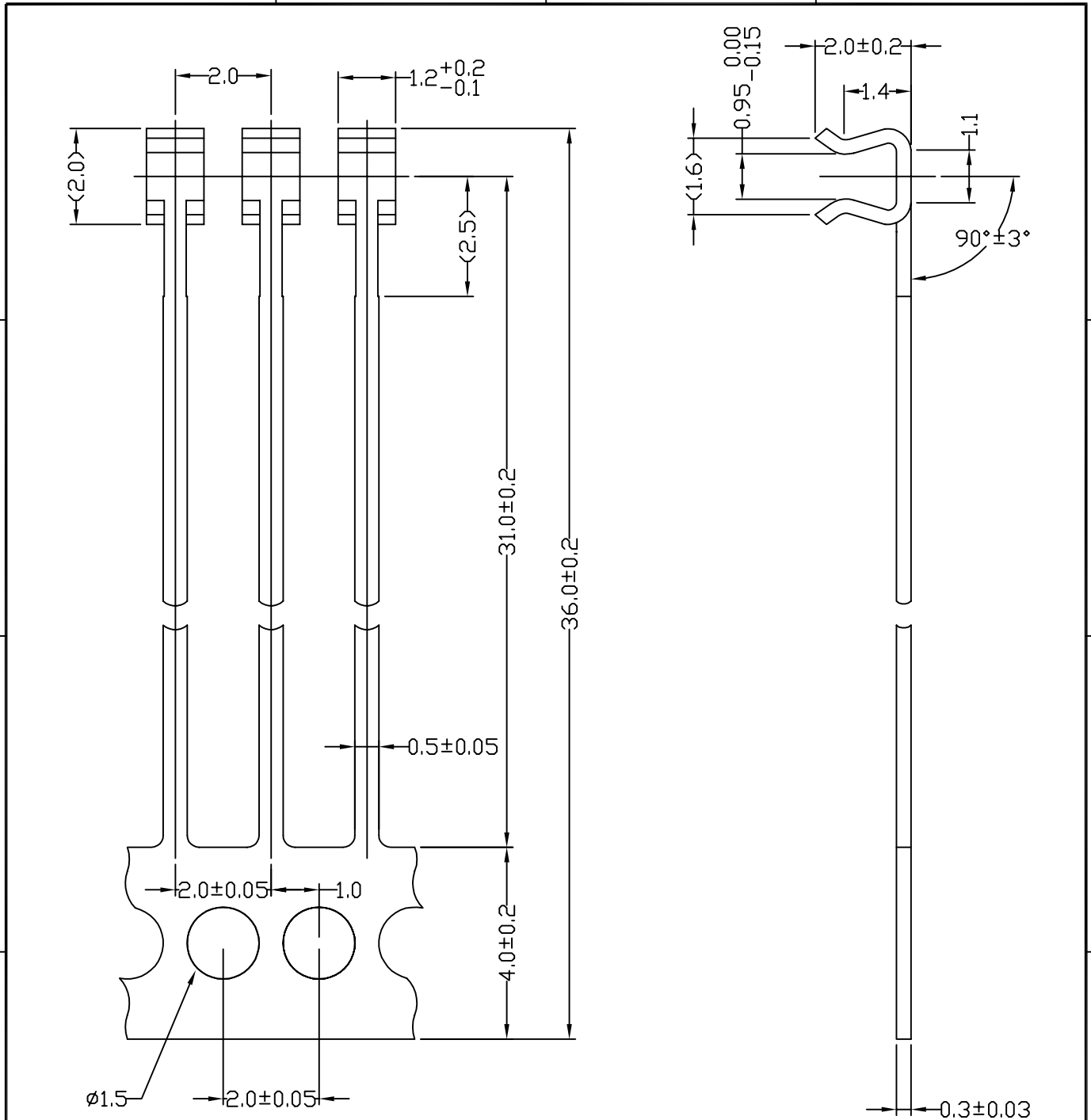



ALLOWANCE	F	G	H	J	K	L	M	N
UNDER 8	± 0.05	± 0.1	± 0.1	± 0.2	± 0.2	± 0.4	± 0.4	± 1.0
8 TO 25	0.08	0.15	0.15	0.3	0.3	0.6	0.6	1.5
25 TO 80	0.12	0.2	0.25	0.4	0.5	0.8	1.0	2.0
80 TO 250	0.25	0.3	0.4	0.6	0.8	1.2	1.5	3.0
250 TO 800	0.5	0.6	0.8	1.0	1.5	2.0	3.0	6.0
800 TO 2500	1.0	1.0	1.5	1.7	3.0	4.0	6.0	12.0
OVER 2500	2.0	2.0	3.0	3.0	6.0	8.0	12.0	24.0

REV	ZONE - CHANGES	ER*	DATE
			99/11/1

A

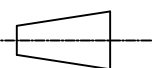
A

NEXT ISSUED :	UNLESS OTHERWISE STATED:		 		 AV DISPLAY (North America) Ltd				
	1/ WALL THICKNESS:								TITLE Pin-271-1.0
	2/ ALL DIM. IN MM		FINISH		MODEL	DWG NO.			
	3/ TOLERANCE:		DRAWN	WU	CHECK	SCALE: 8:1	REV. A PAGE 1 OF 1		
	4/ TEXTURE:		CHECK		APPROVAL	MAT'L & COLOR			
5/ COATING:									
6/ DRAFT ANGLE:									
7/ UNSPECIFIED CORNER:									

4

3

2

1