

4

3

2

1

E

E

D

D

C

C

B

B

A

A

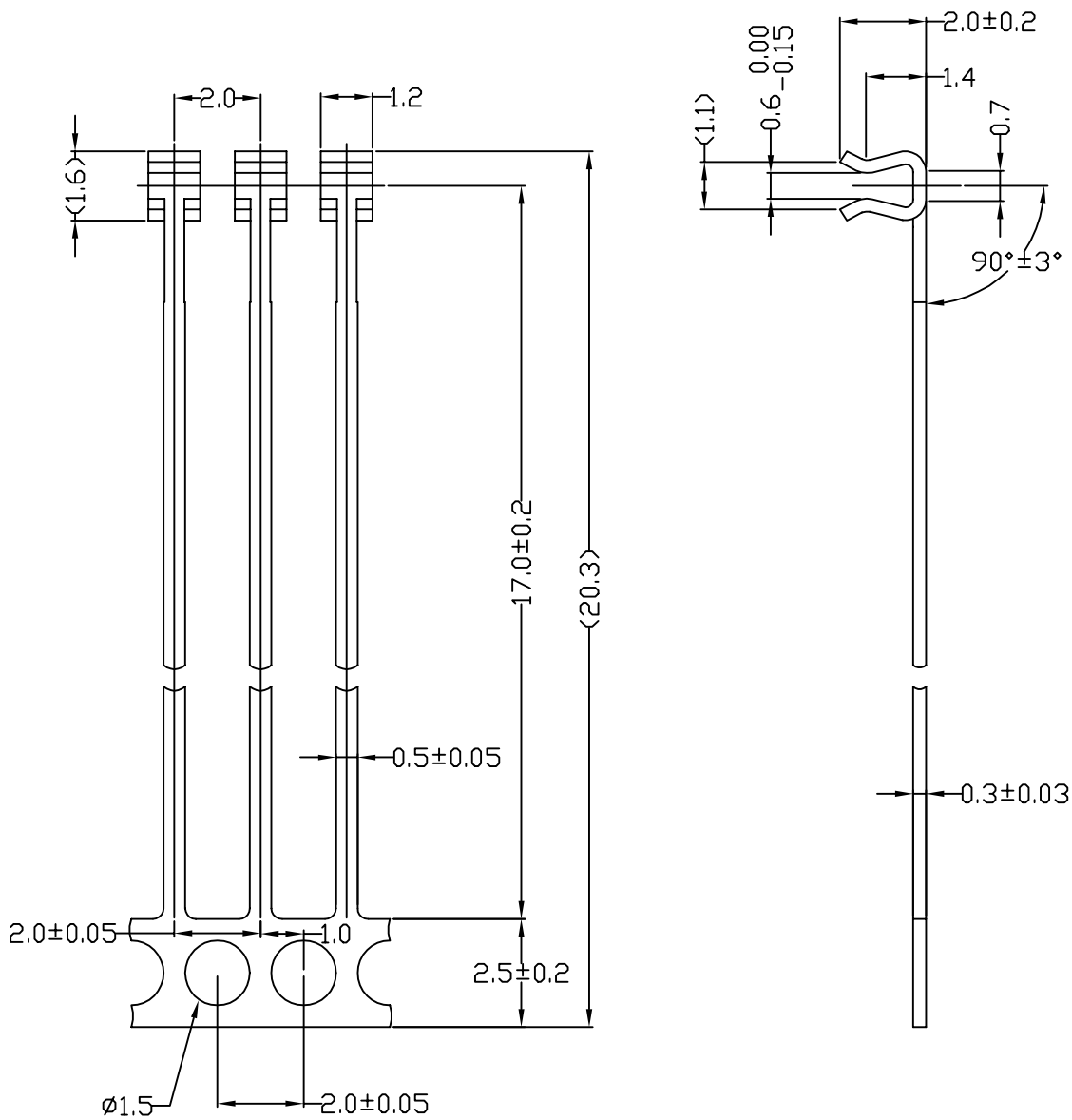

ALLOWANCE	F	G	H	J	K	L	M	N
UNDER 8	±0.05	±0.1	±0.1	±0.2	±0.2	±0.4	±0.4	±1.0
8 TO 25	0.08	0.15	0.15	0.3	0.3	0.6	0.6	1.5
25 TO 80	0.12	0.2	0.25	0.4	0.5	0.8	1.0	2.0
80 TO 250	0.25	0.3	0.4	0.6	0.8	1.2	1.5	3.0
250 TO 800	0.5	0.6	0.8	1.0	1.5	2.0	3.0	6.0
800 TO 2500	1.0	1.0	1.5	1.7	3.0	4.0	6.0	12.0
OVER 2500	2.0	2.0	3.0	3.0	6.0	8.0	12.0	24.0

REV	ZONE - CHANGES	ER*	DATE
			99/10/31

**UNLESS OTHERWISE STATED:**

- 1/ WALL THICKNESS:
- 2/ ALL DIM. IN MM
- 3/ TOLERANCE:  
XX.X+/-  
XX.X+/-  
XXX.X+/-
- 4/ TEXTURE:
- 5/ COATING:
- 6/ DRAFT ANGLE:
- 7/ UNSPECIFIED CORNER:

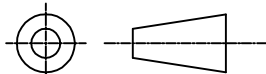

 **AV DISPLAY (North America) Ltd**

FINISH

DRAWN

CHECK

APPROVAL

WU

TITLE Pin-221-0.7

MODEL

SCALE: 6:1

MAT'L &amp; COLOR

DWG NO.

REV. A PAGE 1 OF 1

4

3

2

1