



**SPECIFICATION
FOR
LCD MODULE**

MODULE NO: AFK1280800A0-10.1INTN

REVISION NO: V01

Customer's Approval:

--

	SIGNATURE	DATE
PREPARED BY (RD ENGINEER)		
CHECKED BY		
APPROVED BY		

Records of Revision

DATE	REF.PAGE PARAGRAPH DRAWING No.	REVISED No.	SUMMARY	REMARK
2016-09-10		V01	First Issue	

Contents

1. General Specification.....	4
2. Mechanical Drawing.....	5
3. Block Diagram.....	6
4. Interface Pin Function.....	7
5. Absolute Maximum Ratings.....	8
6. Electrical Characteristics.....	9
7. Optical Characteristics.....	10
8. Timing Characteristics.....	13
9. Standard Specification for Reliability.....	18
10. General Precautions.....	19
11. Packing Method.....	19

1. General Specification

Item	Contents	Unit
LCD TYPE	TFT/TRANSMISSIVE	
MODULE SIZE (W*H*T)	229.6*149.3*2.9	MM
ACTIVE SIZE (W*H)	216.96*135.6	MM
PIXEL PITCH (W*H)	0.1695*0.1695	MM
NUMBER OF DOTS	1280*800	
DIVER IC	TBD	
INTERFACE TYPE	MIPI	
TOP POLARIZER TYPE	ANTI-GLARE	
RECOMMEND VIEWING DIRECTION	ALL	O'CLOCK
GRAY SCALE INVERSION DIRECTION	--	O'CLOCK
COLORS	16.7M	
BACKLIGHT TYPE	36-CHIP WHITE LED	
TOUCH PANEL TYPE	WITHOUT	

2. Mechanical Drawing

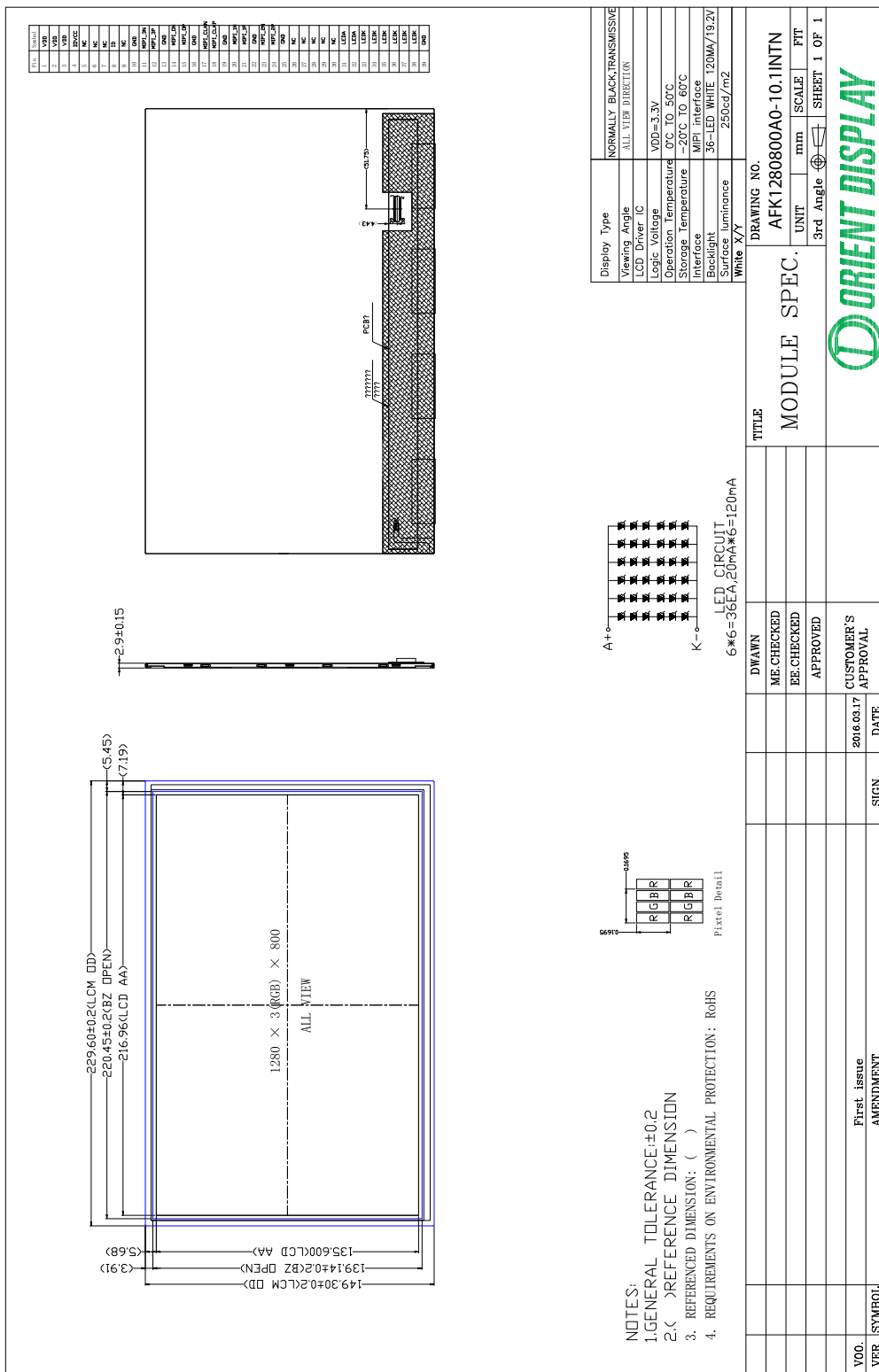

3. Block Diagram

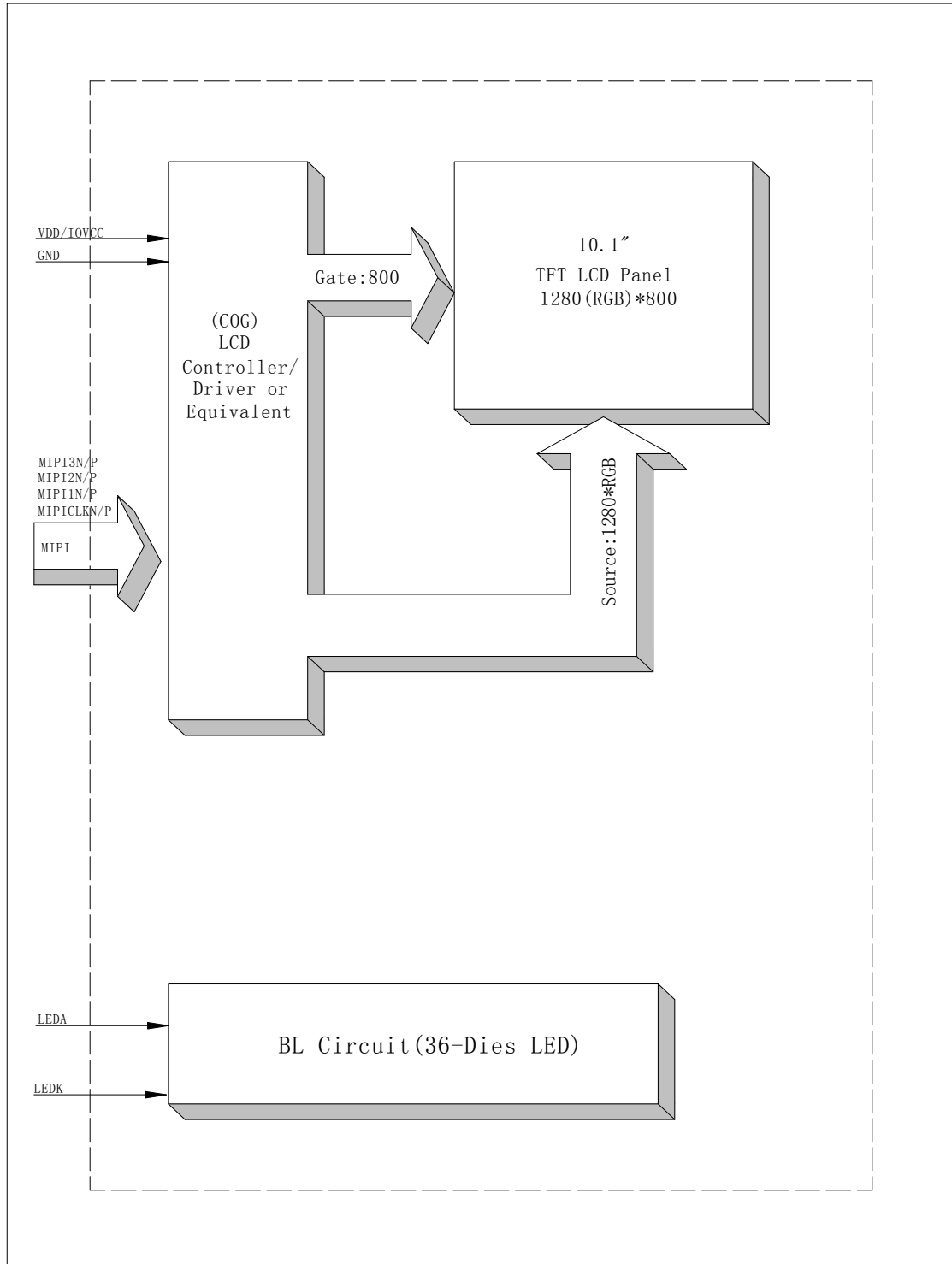

4. Interface Pin Function

Pin No.	Symbol	Description
1	VDD	Logic power 3.3V
2	VDD	Logic power 3.3V
3	VDD	Logic power 3.3V
4	IOVCC	IOVCC(1.8v)
5	NC	No connection
6	NC	No connection
7	NC	No connection
8	ID	Product ID signal output (1.8V)
9	NC	NO CONNECT
10	GND	GROUND
11	MIPI_3N	MIPI DATA NEGATIVE SIGNAL(3N)
12	MIPI_3P	MIPI DATA POSITIVE SIGNAL(3P)
13	GND	GROUND
14	MIPI_0N	MIPI DATA NEGATIVE SIGNAL(0N)
15	MIPI_0P	MIPI DATA POSITIVE SIGNAL(0P)
16	GND	GROUND
17	MIPI_CLKN	MIPI CLK NEGATIVE SIGNAL(CLKN)
18	MIPI_CLKP	MIPI CLK POSITIVE SIGNAL(CLKP)
19	GND	GROUND
20	MIPI_1N	MIPI DATA NEGATIVE SIGNAL(1N)
21	MIPI_1P	MIPI DATA POSITIVE SIGNAL(1P)
22	GND	GROUND
23	MIPI_2N	MIPI DATA NEGATIVE SIGNAL(2N)
24	MIPI_2P	MIPI DATA POSITIVE SIGNAL(2P)
25	GND	GROUND
26	PWMO	TIMING CONTROLLER PWM OUTPUT SIGNAL TO LED DIRVER
27	NC	NO CONNECT
28	NC	NO CONNECT
29	NC	NO CONNECT
30	PWMI	PWM SIGNAL TO TIMING CONTROLLER
31	LEDA	LED ANODE
32	LEDA	LED ANODE
33	LEDK	LED CATHODE
34	LEDK	LED CATHODE
35	LEDK	LED CATHODE
36	LEDK	LED CATHODE
37	LEDK	LED CATHODE
38	LEDK	LED CATHODE
39	GND	GROUND

5. Absolute Maximum Ratings

Parameter	Symbol	Min	Max	Unit
Supply voltage for analog	VDD	-0.3	5	V
Supply voltage for logic	IOVCC	-0.5	5	V
Supply current (One LED)	I _{LED}		60	mA
Operating temperature	T _{OP}	-20	+65	°C
Storage temperature	T _{ST}	-40	+85	°C

Note: The absolute maximum rating values of this product are not allowed to be exceeded at any times. Should a module be used with any of the absolute maximum ratings exceeded, the characteristics of the module may not be recovered, or in an extreme case, the module may be permanently destroyed.

6. Electrical Characteristics

6.1 Input Power

Item	Symbol	Min	Typ.	Max	Unit	Applicable terminal
Supply Voltage for Analog	VDD	3.0	3.3	3.6	V	
Supply Voltage for Logic	IOVCC	3.0	3.3	3.6	V	
Input Voltage	V _{IL}	GND	-	0.3 IOVCC	V	
	V _{IH}	0.7 IOVCC	-	IOVCC		
Input leakage Current	I _{LKG}	-		-	μA	

6.2 Backlight Driving Conditions

Item	Symbol	Value			Unit	Remark
		Min.	Typ.	Max.		
Voltage for LED Backlight	V _F		19.2		V	I _L =120mA
Current for LED Backlight	I _L		120		mA	
Power Consumption	P		2.304		W	
LED Life Time		30,000			Hr	Note

Note: Brightness to be decreased to 50% of the initial value at ambient temperature TA=25°C

7. Optical Characteristics

ITEM	SYMBOL	CONDITIONS	SPECIFICATIONS			UNIT	NOTE
			MIN	TYP.	MAX		
Luminance	L	$I_L = 120\text{mA}$		250		Cd/m^2	
Contrast Ratio	CR	$\theta = 0^\circ$	600	800			
Response Time	T_{ON}	25°C		25		ms	
	T_{OFF}						
CIE Color Coordinate	Red	X_R	Viewing normal angle				
		Y_R					
	Green	X_G					
		Y_G					
	Blue	X_B					
		Y_B					
	White	X_W			TBD		
		Y_W			TBD		
Viewing Angle	Hor.	θ_{X+}	$\text{CR} \geq 10$		80	Degree	
		θ_{X-}			80		
	Ver.	θ_{Y+}			80		
		θ_{Y-}			80		
Uniformity	Un		70	75		%	

Note 1: Definition of Viewing Angle θ_x and θ_y :

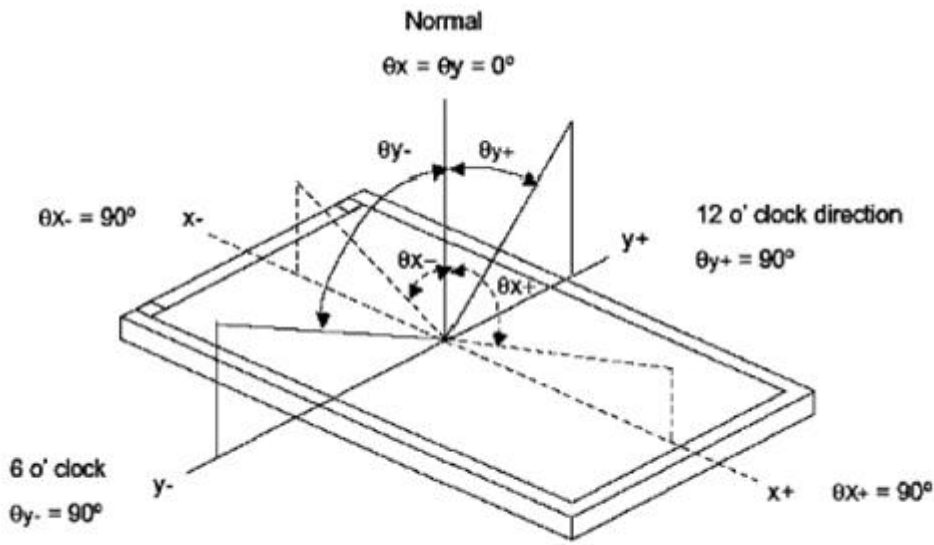

Note 2: Definition of contrast ratio CR:

$$CR = \frac{\text{Luminance of white state}}{\text{Luminance of black state}}$$

Note 3: Definition of Response Time (T_r, T_f)

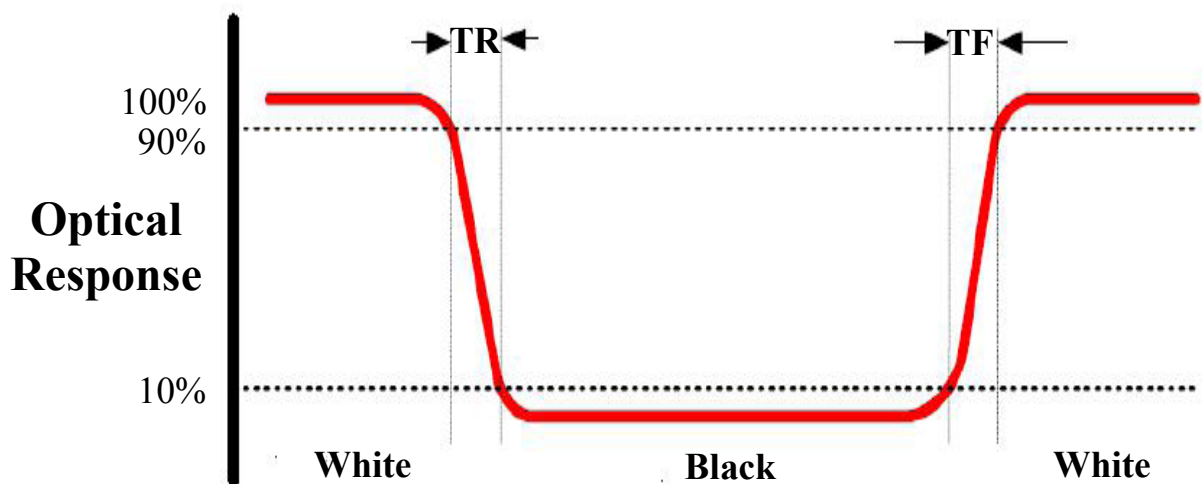

Note 4: Definition of Luminance

①The Brightness Test Equipment Setup

Field=2° (As measuring “black” image, field=2° is the best testing condition)

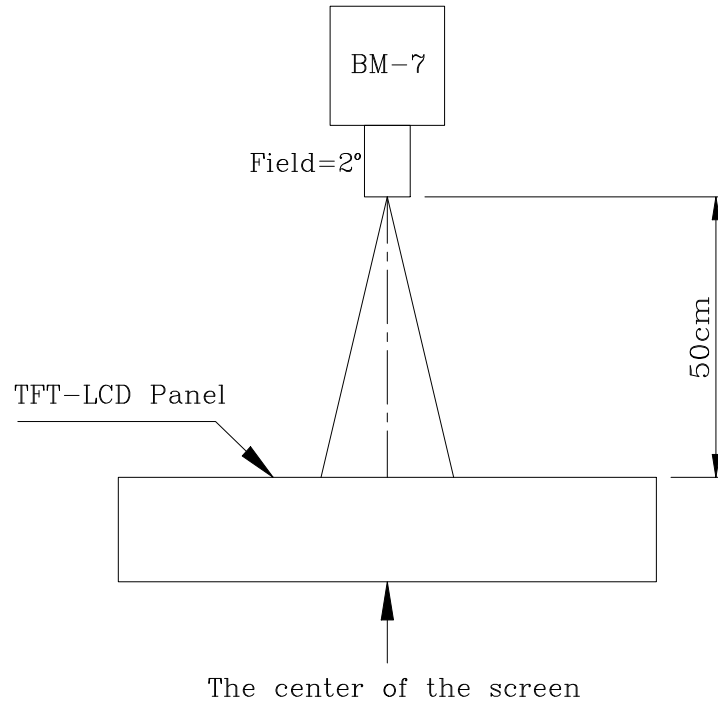

②The Brightness Test Point Setup

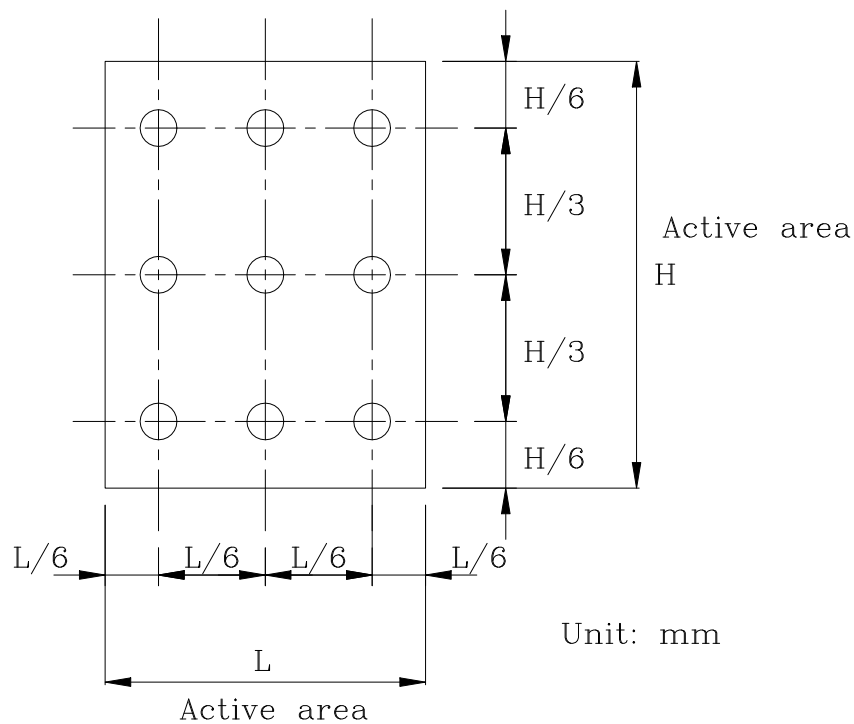

8. Timing Characteristics

8.1 Data input format

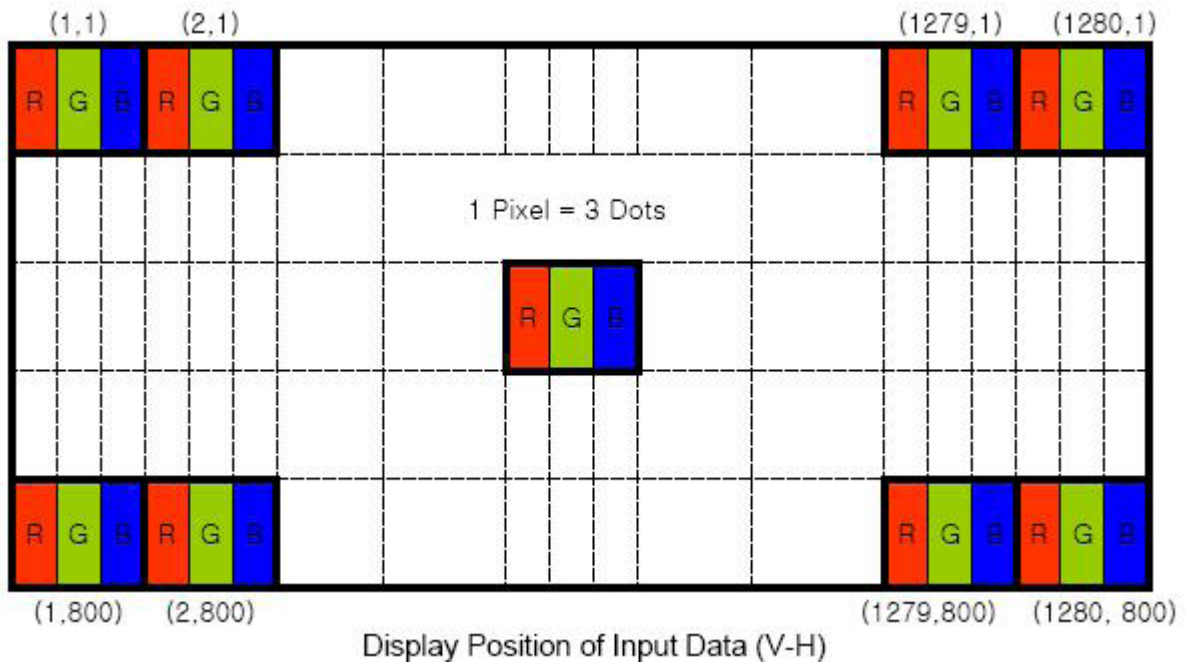

8.2 Signal timing

ITEM	Symbol	Min	Typ	Max	Unit	Note
CLK	Period	t_{CLK}	4	4.44	ns	
	Frequency	-	450	500	Mbps	
Hsync	Period	t_{HP}	-	1330	t_{CLK}	
	Frequency	f_H	-	48.72	-	KHz
Vsync	Period	t_{VP}	-	812	t_{HP}	
	Frequency	f_V	-	60	-	Hz
Horizontal Active Display Term	Valid	t_{HV}	-	1280	t_{CLK}	
	Total	t_{HP}	-	1330	t_{CLK}	
Vertical Active Display Term	Valid	t_{VV}	-	800	t_{HP}	
	Total	t_{VP}	-	812	t_{HP}	

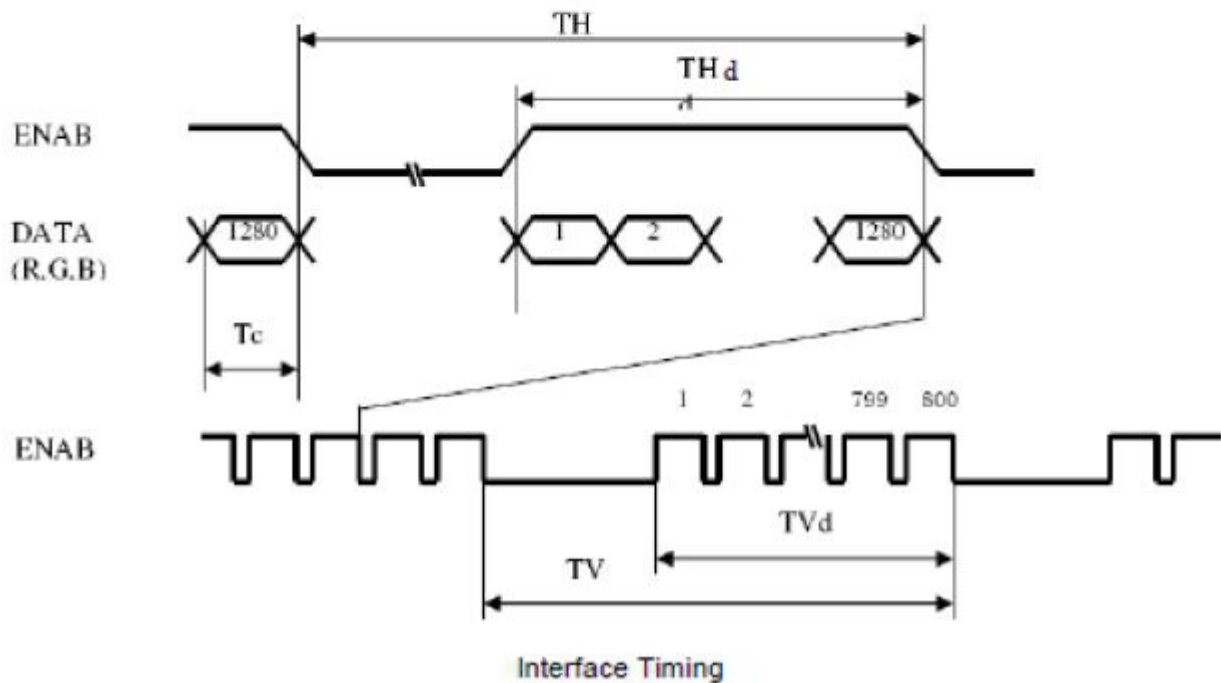

8.3 MIPI Rx Interface Timing Parameter

The specification of the MIPI Rx interface timing parameter is shown in Table 8.

MIPI Rx Interface Timing Specification

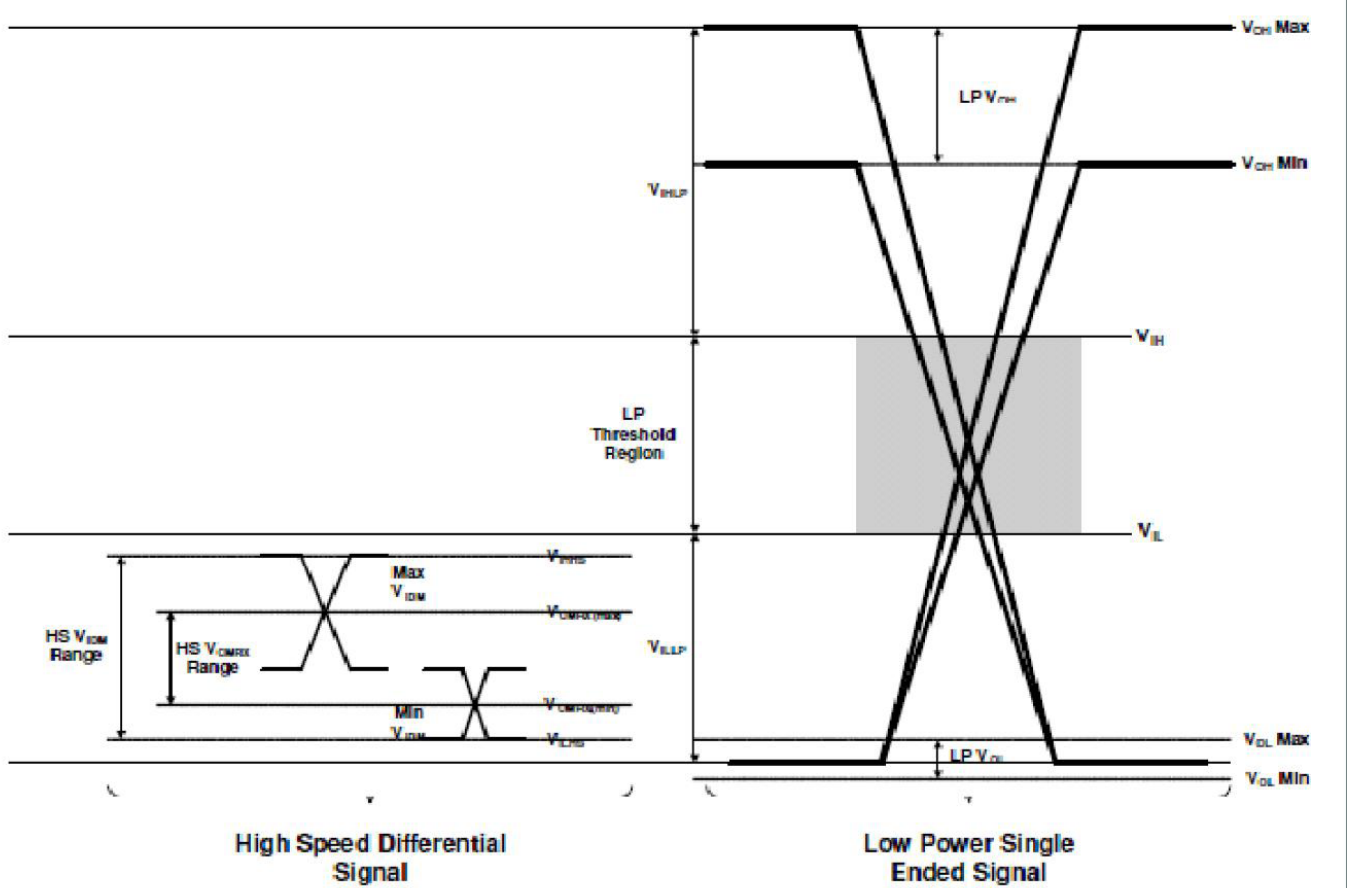

MIPI Receiver Differential Input (DC Characteristics)						
Symbol	Description	Min.	Typ.	Max.	Unit	Condition
BR _{MIPI}	Input data bit rate	200	-	1000	Mbps	
V _{CMRX}	Common-mode voltage(HS Rx mode)	70	-	330	mV	
V _{IDTH}	Differential input high threshold (HS Rx mode)	-	-	70	mV	
V _{IDTL}	Differential input low threshold (HS Rx mode)	-70	-	-	mV	
V _{IDM}	Differential input voltage range (HS Rx mode)	70	-	500	mV	
V _{IHHS}	Single-end input high voltage (HS Rx mode)	-	-	460	mV	
V _{ILHS}	Single-end input low voltage (HS Rx mode)	-40	-	-	mV	
Z _{ID}	Differential input impedance	80	100	125	ohm	
V _{IHLP}	Logic 1 input voltage (LP Rx mode)	880	-	-	mV	
V _{ILLP}	Logic 0 input voltage (LP Rx mode)	-	-	550	mV	
VOH	Output high level (LP Tx mode)	1.08	1.2	1.32	V	
VOL	Output low level (LP Tx mode)	-50	-	50	mV	

MIPI Receiver Differential Input (DC Characteristics)						
Symbol	Description	Min.	Typ.	Max.	Unit	Condition
T _{MIN-RX}	Minimum pulse width response (LP Rx mode)	50	-	-	ns	
T _{L_P-PULS E-TX}	Pulse width of the LP exclusive-OR clock	50	55	58	ns	1st clock pulse after STOP state or last clock pulse before STOP state/all other pulse
T _{RLP/TFLP}	15%~85% rise time and fall time (LP Tx mode)	-	-	25	ns	
T _{REOT}	30%~85% rise time and fall time of EOT (LP Tx mode)	-	-	35	ns	
T _{L_P-PER-T X}	Period of the LP exclusive-OR clock	90	-	-	ns	
T _{SETUP}	Data to clock setup time	0.15	-	-	UI	
T _{HOLD}	Data to clock hold time	0.15	-	-	UI	

8.4 MIPI Rx Interface Timing Parameter

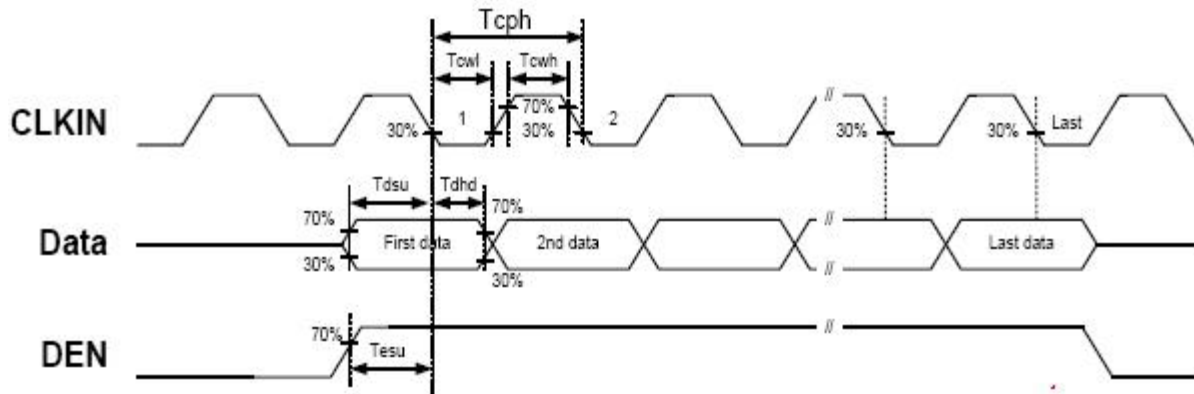

9. Standard Specification for Reliability

9.1 Standard Specification for Reliability of LCD Module

Item	Test Conditions	Remark
High temperature storage	Ta=60°C 240hrs	NOTE1 , NOTE4
Low temperature storage	Ta=-20°C 240hrs	NOTE1 , NOTE4
High temperature operation	Ta=50°C 240hrs	NOTE2 , NOTE4
Low temperature operation	Ta=0°C 240hrs	NOTE2 , NOTE4
Operate at high temperature and humidity	+60°C, 90%RH 240hrs	NOTE4
Thermal Shock	-20°C/30min~+60°C/30min for a total 100 cycles, start with cold temperature and end with high temperature.	NOTE4
Vibration Test	Frequency range:10~55HZ Stroke:1.5mm Swap:10HZ~55HZ~10HZ 2 hours of each direction of X.Y. Z (6 hours for total)	
Mechanical shock	200G 2ms, ±X, ±Y, ±Z 3 times for each direction	
Package vibration test	Random vibration :1.5G*G/HZ from 10-500 HZ,-6dB/Octave from 200-500HZ of each direction of X.Y. Z (6 hours for total)	
Low temperature storage	Height:60cm 1 corner ,3 edges ,6 surfaces	
Low temperature storage	AIR: 150pF,330 Ω , 15KV CONTACT:150pF,330 Ω , 8KV	

Note 1: Ta is the ambient temperature of samples.

Note 2: Ts is the temperature of panel's surface.

Note 3: In the standard condition, there shall be no practical problem that may affect the display function. After the reliability test, the product only guarantees operation, but don't guarantee all of the cosmetic specification.

Note 4: Before cosmetic and function test, the product must have enough recovery time, at least 2 hours at room temperature.

10. General Precautions

10.1. Safety

- Liquid crystal is poisonous. Do not put it in your mouth. If liquid crystal touches your skin or clothes, wash it off immediately by using soap and water.

10.2. Handling

- The LCD panel is plate glass. Do not subject the panel to mechanical shock or to excessive force on its surface.
- The polarizer attached to the display is easily damaged. Please handle it carefully to avoid scratch or other damages.
- To avoid contamination on the display surface, do not touch the module surface with bare hands.
- Keep a space so that the LCD panels do not touch other components.
- Put cover board such as acrylic board on the surface of LCD panel to protect panel from damages.
- Transparent electrodes may be disconnected if you use the LCD panel under environmental conditions where the condensation of dew occurs.
- Do not leave module in direct sunlight to avoid malfunction of the ICs.

10.3. Static Electricity

- Be sure to ground module before turning on power or operating module.
- Do not apply voltage which exceeds the absolute maximum rating value.

10.4. Storage

- Store the module in a dark room where must keep at $25\pm 10^{\circ}\text{C}$ and 65%RH or less.
- Do not store the module in surroundings containing organic solvent or corrosive gas.
- Store the module in an anti-electrostatic container or bag.

10.5. Cleaning

- Do not wipe the polarizer with dry cloth. It might cause scratch.
- Only use a soft sloth with IPA to wipe the polarizer, other chemicals might permanent damage to the polarizer.

11. Packing Method

----TBD